



SERVICE
MANUAL **PM440**



marantz®

model PM440

Stereo Pre Main Amplifier

485

MARANTZ DESIGN AND SERVICE

Using superior design and selected high grade components, MARANTZ company has created the ultimate in stereo sound. Only **original MARANTZ parts** can insure that your MARANTZ product will continue to perform to the specifications for which it is famous.

Parts for your MARANTZ equipment are generally available to our National Marantz Subsidiary or Agent.

ORDERING PARTS:

Parts can be ordered either by mail or by telex. In both cases, MARANTZ part number has to be specified. If you order by mail, fulfil MARANTZ order forms.

MARANTZ S.A.
EUROPEAN PARTS DEPARTMENT
2, Avenue Léopold III
B-7120 PERONNES-lez-BINCHE
BELGIUM
TWX: 57589 SEPLT B

SUPERSCOPE NATIONAL PARTS DEPARTMENT
20525 Nordhoff Street
Chatsworth, California 91311
Phone: 1-800-423-5108
Phone: 1-213-998-9333

The following information must be supplied to eliminate delays in processing your order:

1. Complete address
2. Complete part numbers and quantities required
3. Description of parts
4. Model number for which part is required
5. Way of shipment
6. Signature: any order form or telex must be signed otherwise such part order will be considered as null and void.

PARTS ORDERING:

Parts may be ordered from the following addresses:

EUROPE

MARANTZ S.A.
European Parts Department
2, Avenue Léopold III
B-7120 Péronnes-lez-Binche
Belgium
Telex: 57589

MARANTZ DENMARK
Bregnerødvej 132b
3460 Birkerød
Denmark
Telex: 39137

MARANTZ BELGIUM
45 Rue Auguste Van Zande
1080 Brussels
Belgium

MARANTZ NEDERLAND B.V.
Wagenmackersweg 3
3449 H.V. Woerden
Netherlands

MARANTZ AUSTRIA Ge.M.B.H.
25 Franz Lisztgasse
2380 Perchtoldsdorf
Austria
Telex: 113583

MARANTZ S.A.
326 Avenue Louise Bte 32
1050 Bruxelles
Belgium
Telex: 26602

MARANTZ FRANCE
4 Rue Bernard Palissy
92600 Asnières
France
Telex: 611651

MARANTZ SVENSKA A.B.
Svartviksvägen 56
Träneberg Bromma
Sweden
Telex: 13449

MARANTZ ITALIANA S.p.A.
Via Monte Napoleone, 10
20121 Milano
Italia

MARANTZ GERMANY G.M.B.H.
Max-Planckstrasse 22
6072 Dreieich 1
Germany
Telex: 4185316

MARANTZ AUDIO U.K. LTD.
Unit 15/16
Saxon Way Industrial Estate
Moor Lane
Harmondsworth UB7 0LW
Great Britain
Telex: 935196

AUSTRALIA

MARANTZ AUSTRALIA PTY., LTD.
19 Chard Road
Brookvale, NSW 2100
Australia
Telex: 24121

U.S.A.

MARANTZ COMPANY, INC.
National Service Dept.
P.O. Box 577
Chatsworth, CA 91311
U.S.A.
Telex: 4720284

JAPAN

MARANTZ JAPAN, INC.
35-1, 7-chome, Sagamiono
Sagamihara-shi, Kanagawa
Japan
Telex: 22878

All of the above locations are fully equipped to take care of your total service needs. Because various countries have differing configuration requirements, it is necessary that you contact the service facility in your particular country. In the event that there is no service location listed for your country, please, contact the nearest facility for the necessary assistance.

In case of difficulties, do not hesitate to contact the Technical Department at abovementioned address.

NOTE—FOR U.S.A. ONLY

Parts for your MARANTZ stereo are generally available within 72 hours throughout the nation via a toll-free line to our National Parts Depot in California. The sales professionals who take your call immediately refer to their own desk top computer terminal and can quickly determine the availability and price information you require. If, for some reason, your order should exceed our available stock, we usually can instantly provide an alternate replacement part or current delivery information. When the order is placed and confirmed, the computer simultaneously generates "hard copy" orders at the distribution center. As hard copies come directly from the computer to the national parts depot, your requested stock is assembled and prepared for shipment and placed on the first available carrier for delivery to you.

Phone orders will eliminate mail delays, and we encourage the use of this method. If you order by mail, use MARANTZ parts order forms which are available from SUPERSCOPE NATIONAL PARTS DEPARTMENT.

marantz®

TABLE OF CONTENTS

SECTION	PAGE
INTRODUCTION	1
1. SHOCK, FIRE HAZARD SERVICE TEST	1
2. P.W BOARD	1
4. TEST EQUIPMENT REQUIRED FOR SERVICING	2
3. ADJUSTMENT PROCEDURES	2
5. FUNCTIONAL EXPLANATION	2
6. VOLTAGE CONVERSION	3
7. BLOCK DIAGRAM	4
8. DIAGRAM AND COMPONENT LOCATIONS	5
8.1 Speaker Switch Assembly (PN01) Schematic Diagram and Component Locations	5
8.2 Power Switch Assembly (PP01) Schematic Diagram and Component Locations	5
8.3 Headphone Jack Assembly (PW01) Schematic Diagram and Component Locations	5
8.4 Speaker Lamp Assembly (PX01) Schematic Diagram and Component Locations	5
8.5 Main Amp. Assembly (P701) Schematic Diagram and Component Locations	6
8.6 Volume Assembly (PE01) Schematic Diagram and Component Locations	6
9. EXPLODED VIEW AND PARTS LIST	10
10. ELECTRICAL PARTS LIST	12
11. TECHNICAL SPECIFICATIONS	16
12. SCHEMATIC DIAGRAM	18

MODEL PM440 STEREO PRE MAIN AMPLIFIER

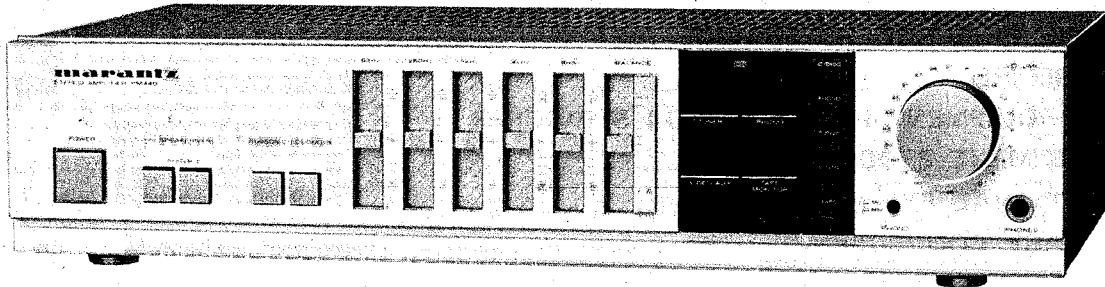

INTRODUCTION

This service manual was prepared for use by Authorized Warranty Stations and contains service information for the Marantz Model PM440 Stereo Pre Main Amplifier.

Servicing information and voltage data included in this manual are intended for use by knowledgeable and experienced personnel only. All instructions should be read carefully. No attempt should be made to proceed without a good understanding of circuitry operation.

The parts list furnishes complete ordering information. Most replacement parts should be ordered from the Marantz Company. However, a simple description is included for parts which can be obtained locally.

1. SHOCK, FIRE HAZARD SERVICE TEST:

CAUTION: After servicing this appliance and prior to returning to customer, measure the resistance between either primary AC cord connector pins (with unit NOT connected to AC mains and its Power switch ON), and the face or front Panel of product and controls and chassis bottom.

Any resistance measurement less than 1 Megohms should cause unit to be repaired or corrected before AC power is applied, and verified before return to user/customer.

REF UL Standard No. 1270, Para. 66. 3. D (Mandatory Test after servicing Electrical Appliances, effective 7-1-83).

2. P.W. BOARDS

As can be seen from the circuit diagram the chassis of Model PM440 consists of the following units. Each unit mounted on a printed circuit board is described within the square enclosed by a bold dotted line on the circuit diagram.

1. Main Amp. mounted on P.W. Board P701
2. Volume mounted on P.W. Board PE01
3. Speaker Switch mounted on P.W. Board PN01
4. Power Switch mounted on P.W. Board PP01
5. Headphone Jack mounted on P.W. Board PW01
6. Speaker Lamp mounted on P.W. Board PX01

3. TEST EQUIPMENT REQUIRED FOR SERVICING

This table lists the test equipment required for servicing the Model PM440 Stereo Pre Main Amplifier.

Item	Use
Distortion Analyzer	Distortion measurements
Audio Oscillator	Sinewave and squarewave signal source
AC VTVM	Voltage measurements (AC)
Oscilloscope	Waveform analysis and trouble shooting and ASO alignment
Circuit Tester	Trouble shooting
DC VTVM	Voltage measurements (DC)
AC Wattmeter	Monitors primary power to amplifier
Line Voltmeter	Monitors potential of primary power to amplifier
Variable Autotransformer (0 ~ 140V AC, 10A)	Adjust level of primary power to amplifier
Shorting Plug	Shorts amplifier input to eliminate noise pickup

4. ADJUSTMENT PROCEDURES

IDLING ADJUSTMENT

1. Set the input and the output of the unit to OPEN.
2. Connect a digital voltmeter between TP-1 and TP-2 of channel L, and between TP-3 and TP-4 of channel R.
3. Turn on the power switch, wait for 10 seconds, and then adjust R735 of channel L and R736 of channel R so that the digital voltmeter registers 12 mV (22 mA).

5. FUNCTIONAL EXPLANATION

1. FUNCTION SWITCH

This unit can store more than one week's schedule in its memory, thanks to the four source-one monitor high voltage resistant analogue function switch IC and the capacitor backup for the memory. When the charge of the memory backup reaches zero, the tuner will be initialized. Additionally, the mute signal for the popping sound caused when the function is switched is output from DS02 so that the input of the main amplifier will be muted.

2 TONE AMPLIFIER

The tone amplifier features a simple design that uses a single operational amplifier. The level of 100 Hz and 10 kHz can be controlled over a range of ± 10 dB, and the gain is approximately 20 dB. The output stage is connected to the subsonic filter formed by CE21 and CE22 (0.068 μ F). 0.

3. POWER AMPLIFIER

The power amplifier uses the monolithic IC UPC1270H which includes a driver stage as the voltage amplifier, and discrete power transistors for the final stage.

4. PHONO EQUALIZER AMPLIFIER

The high gain phono amplifier uses an FET differential amplifier together with an operational amplifier input stage. Low output designs such as MC cartridges can be used as well as MM, MI, or other high output cartridge designs.

5. GRAPHIC EQUALIZER

The first stage is a buffer amplifier which amplifies the input by approximately 6 dB. QE01 and QE02 (STK 6325A) of the second stage are the graphic equalizer ICs. They form a five band graphic equalizer (63 Hz, 25 Hz, 1 kHz, 4 kHz, 16 kHz).

6. VOLTAGE CONVERSION

• EUROPEAN MODEL ONLY

To convert the unit to a different power source voltage, change the position as illustrated in the drawing below.

CAUTION
DISCONNECT POWER SUPPLY CORD FROM AC
OUTLET BEFORE CONVERTING VOLTAGE.

Voltage Conversion Chart

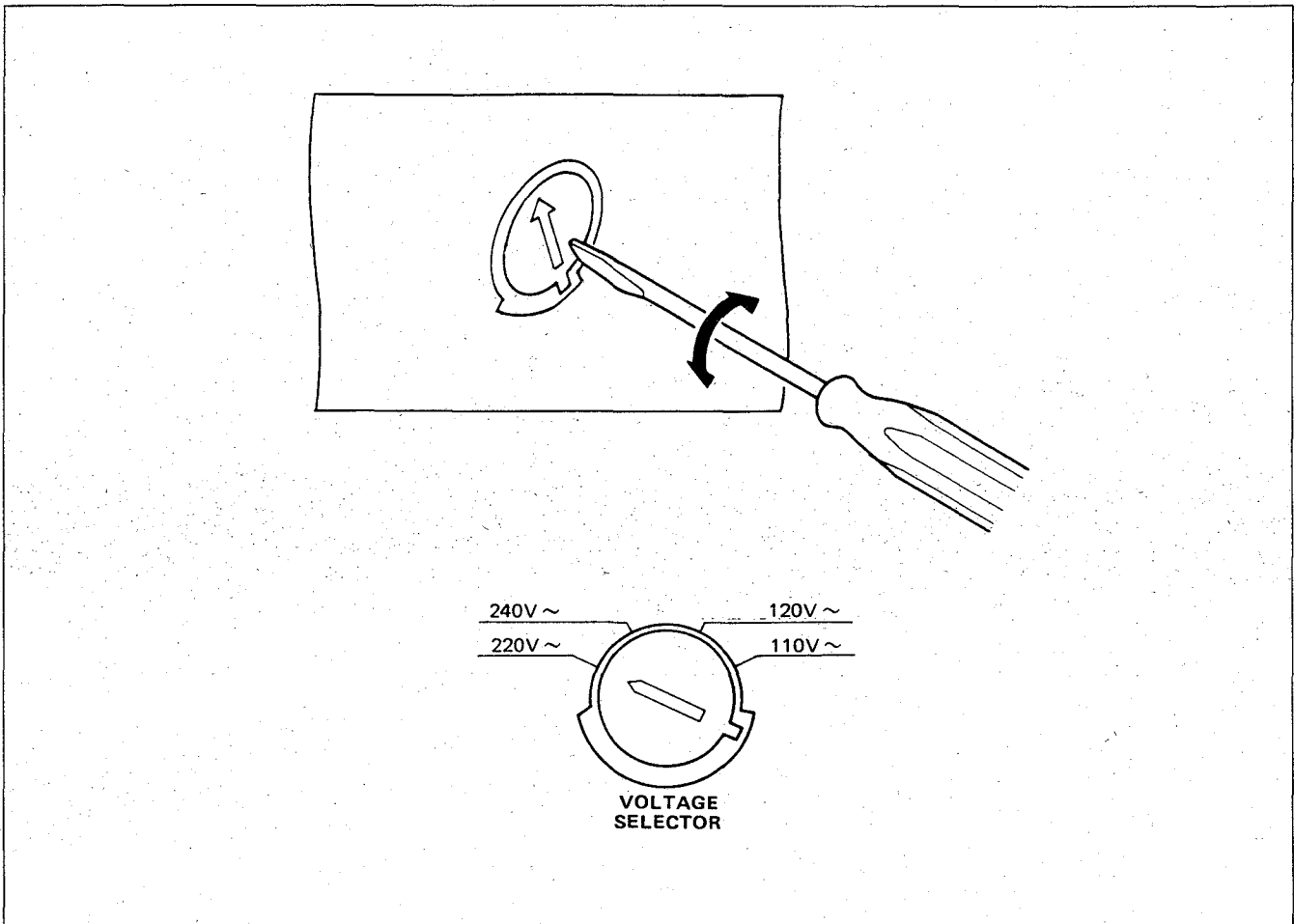

Note on safety: Symbol \triangle Fire or electrical shock hazard. Only original parts should be used to replace any part marked with symbol \triangle . Any other component substitution (other than original type), may increase risk of fire or electrical shock hazard.

7. BLOCK DIAGRAM

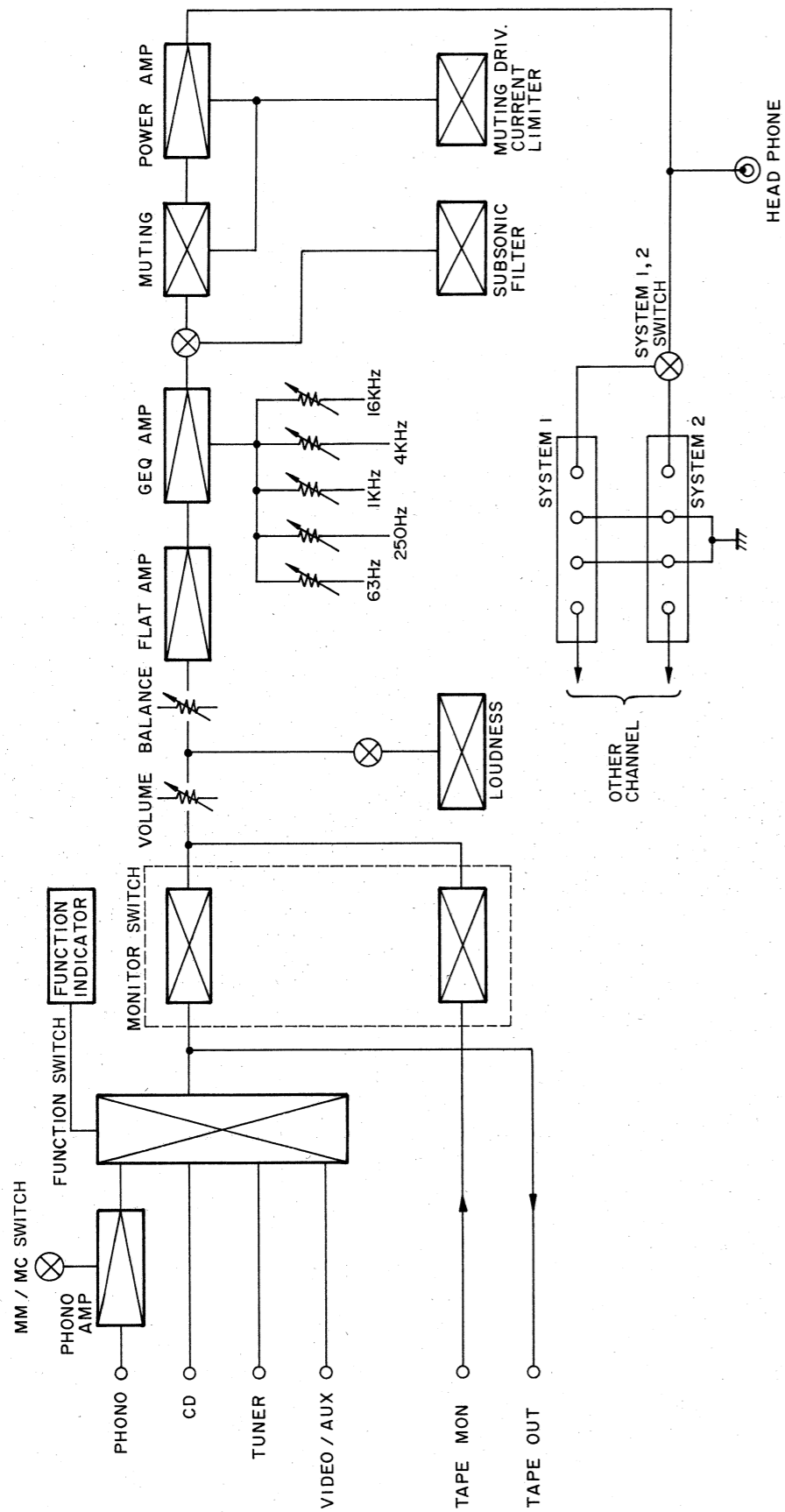

8. DIAGRAM AND COMPONENT LOCATIONS

8.1 Speaker Switch Assembly (PN01)
Schematic Diagram and Component Locations

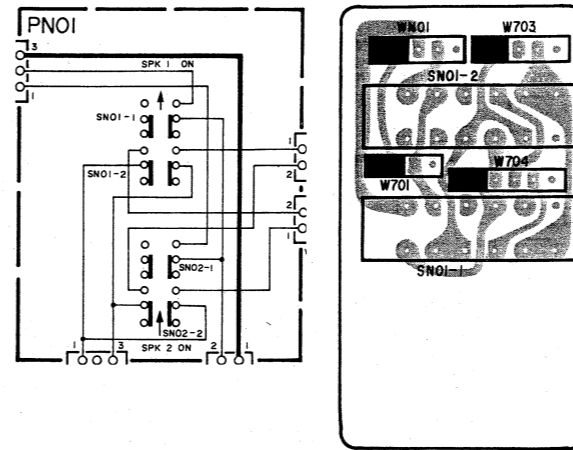

8.2 Power Switch Assembly (PP01)
Schematic Diagram and Component Locations

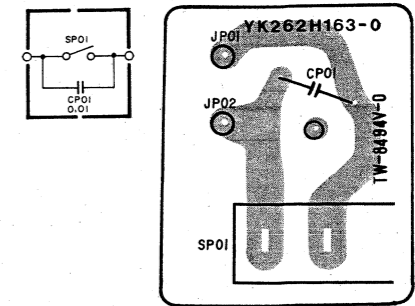

8.3 Headphone Jack Assembly (PW01)
Schematic Diagram and Component Locations

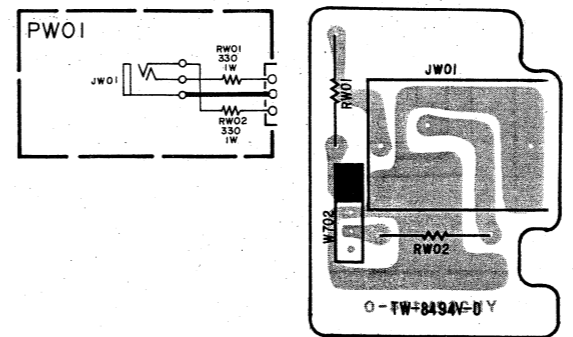

8.4 Speaker Lamp Assembly (PX01)
Schematic Diagram and Component Locations

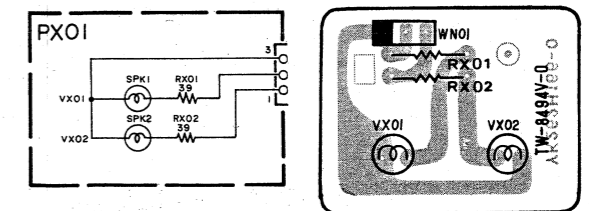

8.5 Main Amp. Assembly (P701)
Schematic Diagram and Component Locations

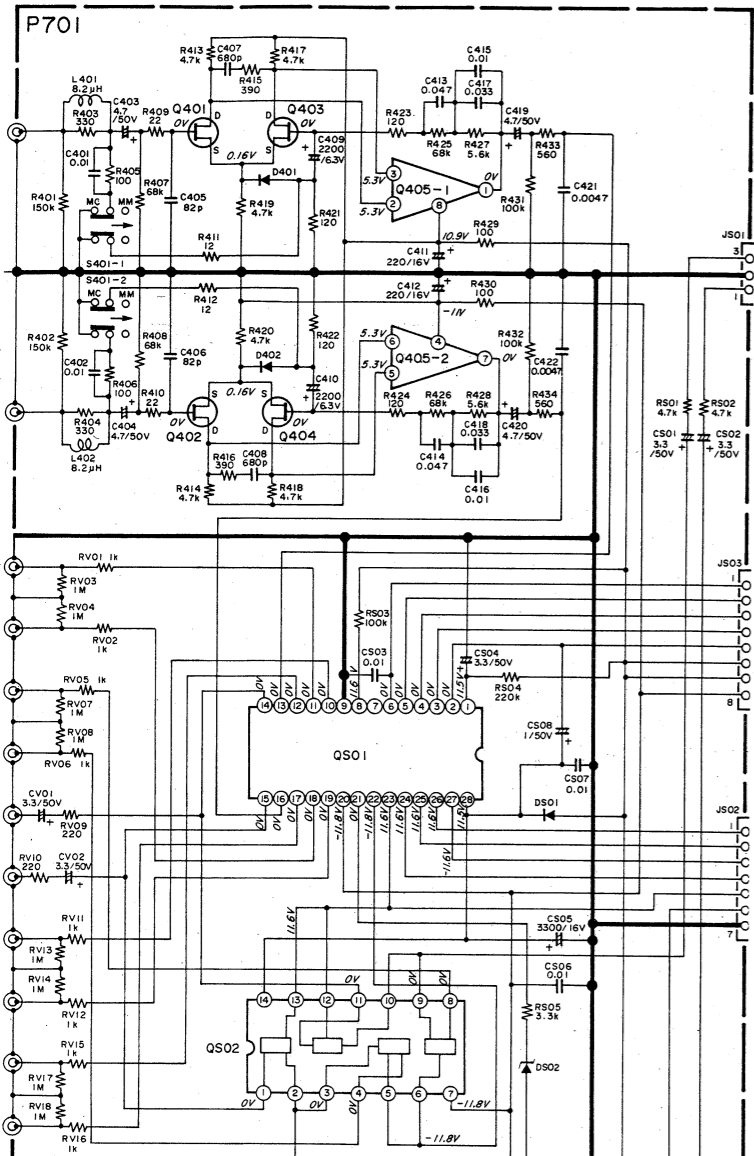

8.6 Volume Assembly (PE01) Schematic Diagram and Component Locations

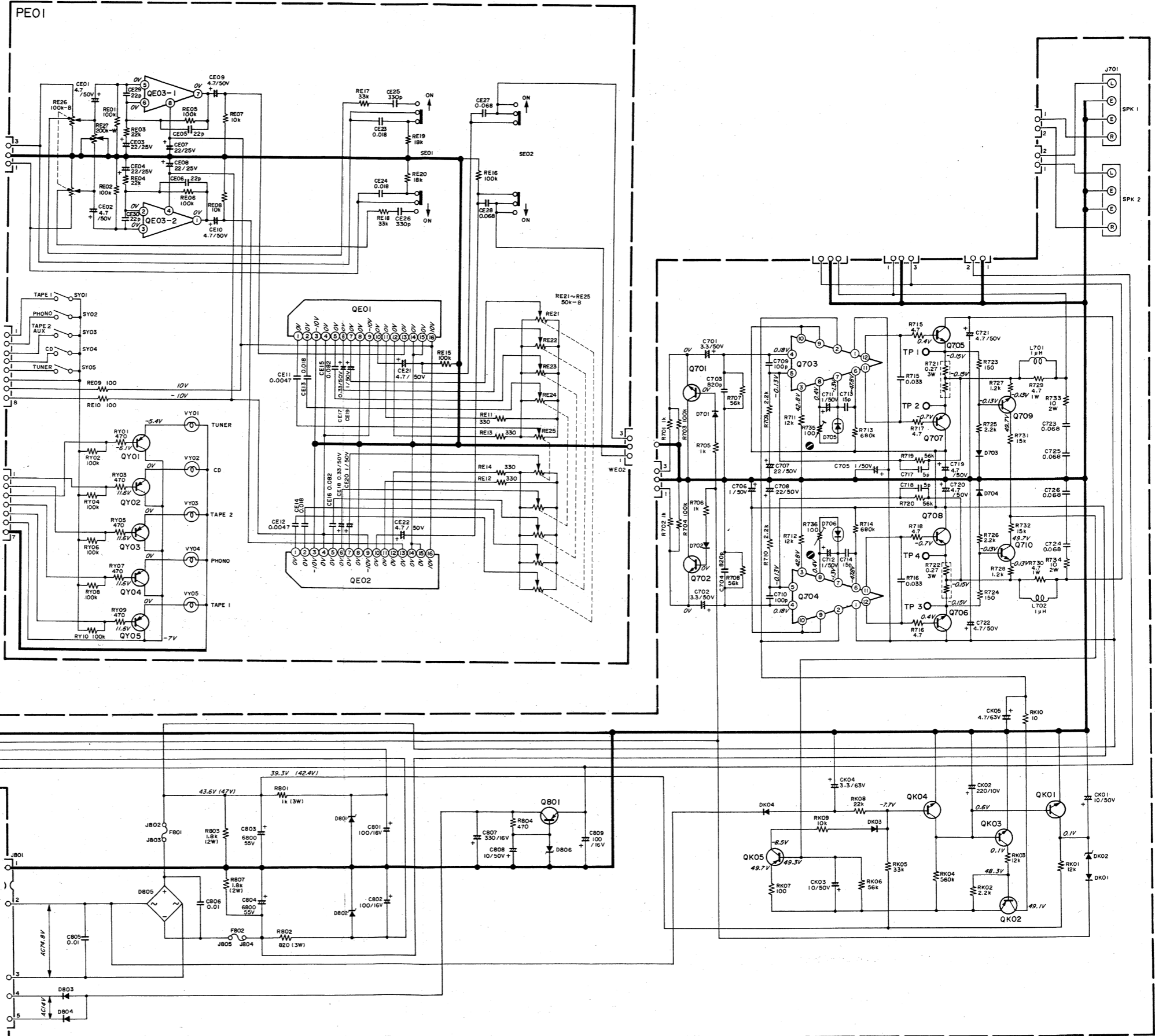

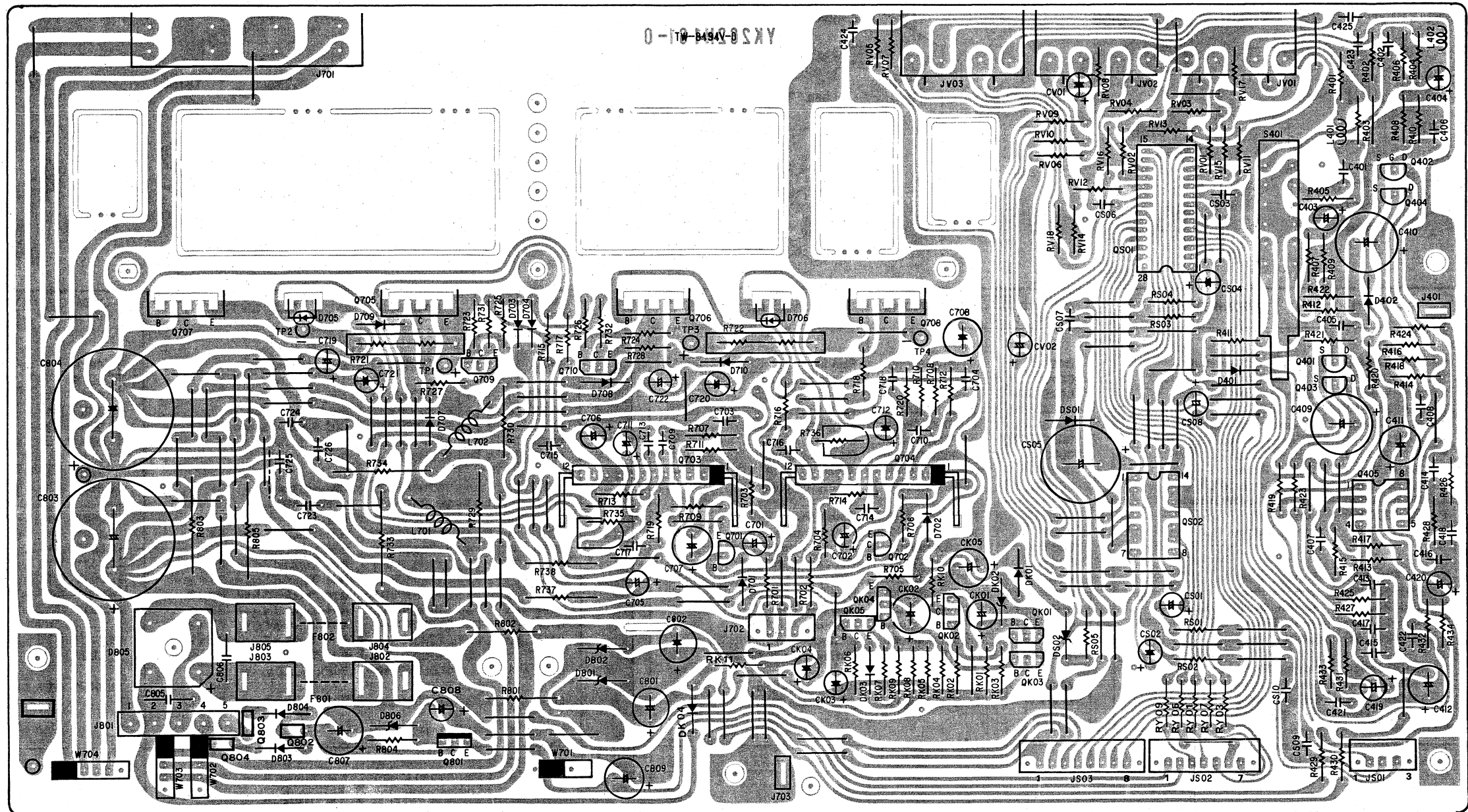
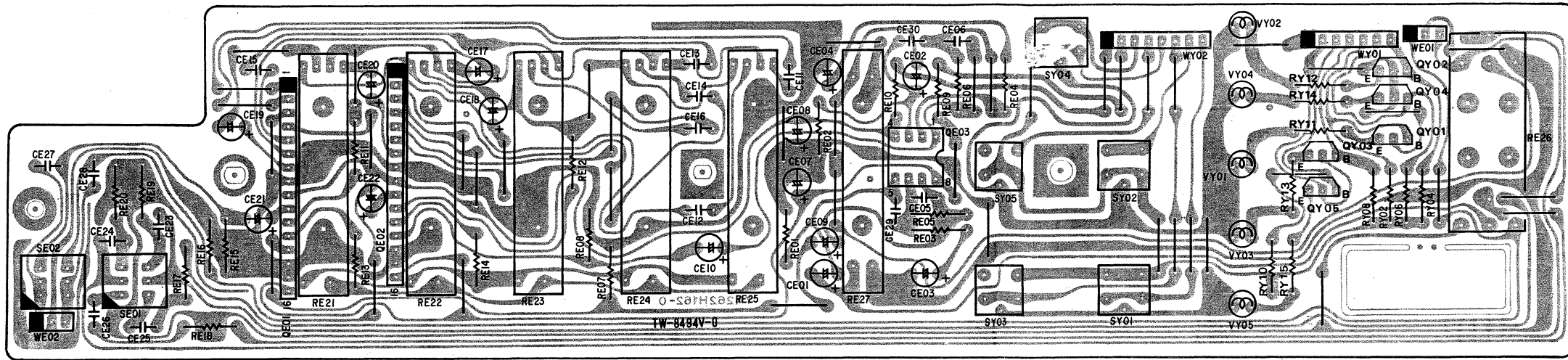

9. EXPLODED VIEW AND PARTS LIST

• [P01-99] Front Panel/Chassis and Packing Materials

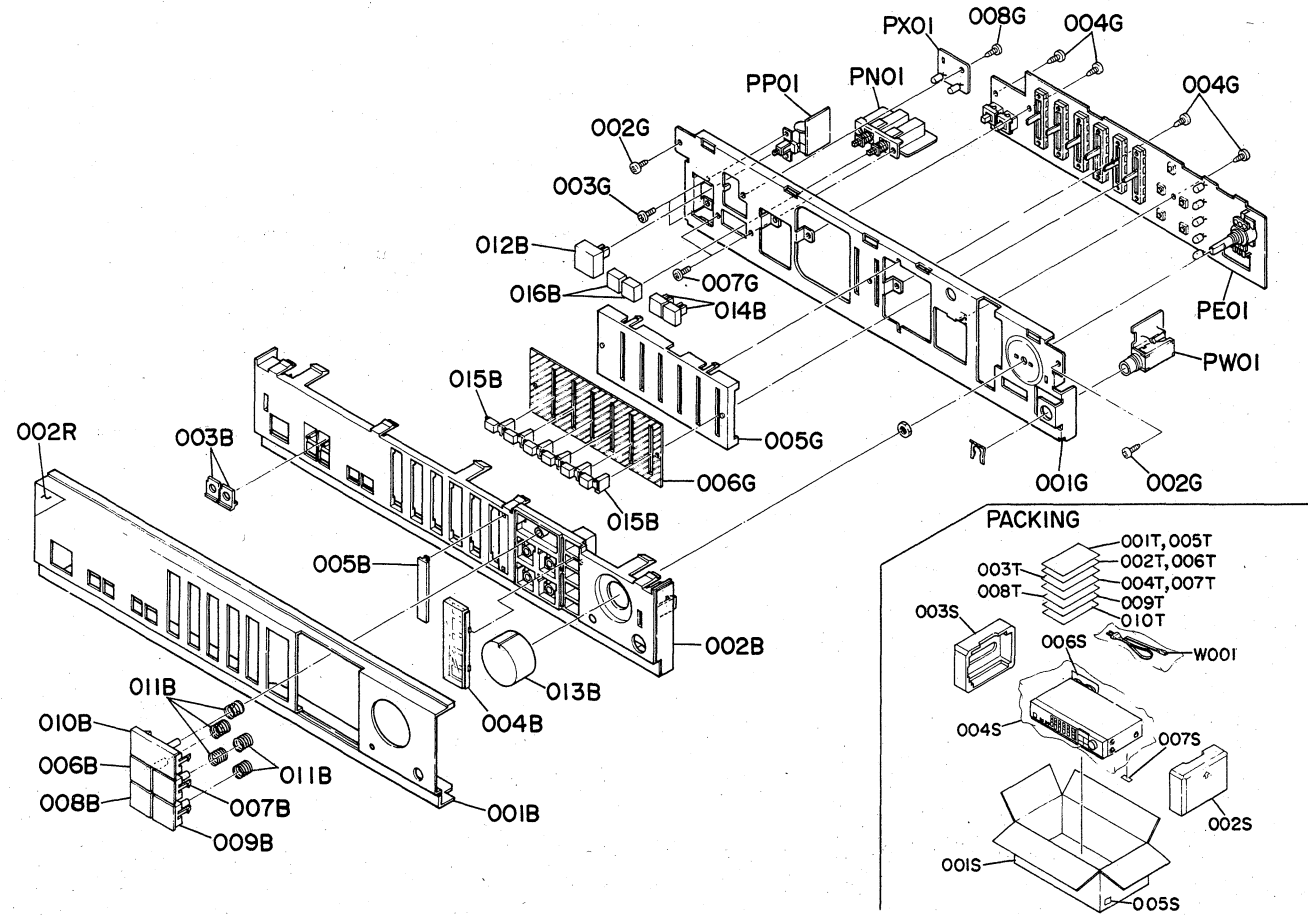

REF. DESIG.	Q'TY			PART NO.	DESCRIPTION
	U	N	A		
A	1	1	1	262H248400	Front Panel Assembly
001B	1	1	1	262H248010	Front Panel
002B	1	1	1	261H105050	Chassis, Front
003B	2	2	2	158T355010	Lens, Speaker
004B	1	1	1	261H265030	Indicator, Function
005B	1	1	1	261H265010	Indicator, Balance
006B	1	1	1	261H270010	Button, Tuner
007B	1	1	1	261H270020	Button, Phono
008B	1	1	1	261H270030	Button, Video/AUX
009B	1	1	1	261H270040	Button, Tape Monitor
010B	1	1	1	261H270050	Button, CD
011B	5	5	5	261H115010	Spring, Button
012B	1	1	1	158T270010	Button, Power
013B	1	1	1	261H154010	Knob, Volume
014B	2	2	2	262H270020	Button, Subsonic/Loudness
015B	6	6	6	261H154020	Knob, Balance EQ
016B	2	2	2	242H270020	Button, Speaker
001G	1	1	1	261H105010	Chassis, Front
002G	2	2	2	51280308B0	B.H. Tapped Screw B3 x 8
003G	2	2	2	51100306A9	B.H.M. Screw B3 x 6
004G	4	4	4	51280308B0	B.H. Tapped Screw B3 x 8
005G	1	1	1	261H053010	Cover, Tone
006G	1	1	1	261H265020	Indicator
007G	2	2	2	51100306A9	B.H.M. Screw B3 x 6
008G	1	1	1	51280308B0	B.H. Tapped Screw B3 x 8
002R	1			105H861010	Label

REF. DESIG.	Q'TY			PART NO.	DESCRIPTION
	U	N	A		
001S	1			262H801020	Packing Case
001S	1	1	1	262H801010	Packing Case
002S	1	1	1	261H809010	Cushion, (R)
003S	1	1	1	261H809020	Cushion, (L)
004S	1	1	1	9090808030	Polyethylene Sheet
005S	2			9526019010	Serial No. Card
005S	4			9526019060	Serial No. Card
005S	4			9526019030	Serial No. Card
006S	1			2918107390	Sheet, AC Cord
001T	1	1		262H851310	User Manual
002T	1	1		262H851320	User Manual
003T	1			262H856010	Circuit Diagram
004T	1			9631000090	Warranty Card
005T	1			262H851210	User Manual
006T	1			262H851220	User Manual, Spec
007T	1			103H854010	Warranty Card
008T	1			2225813010	Envelope
009T	1			9650000050	S. Station Card
010T	1			101K854210	Warranty Card, Canada
ΔW001	1			ZC01805010	A.C. Power Cord
ΔW001	1			ZC02006020	A.C. Power Cord

• [P02-99] Main Chassis

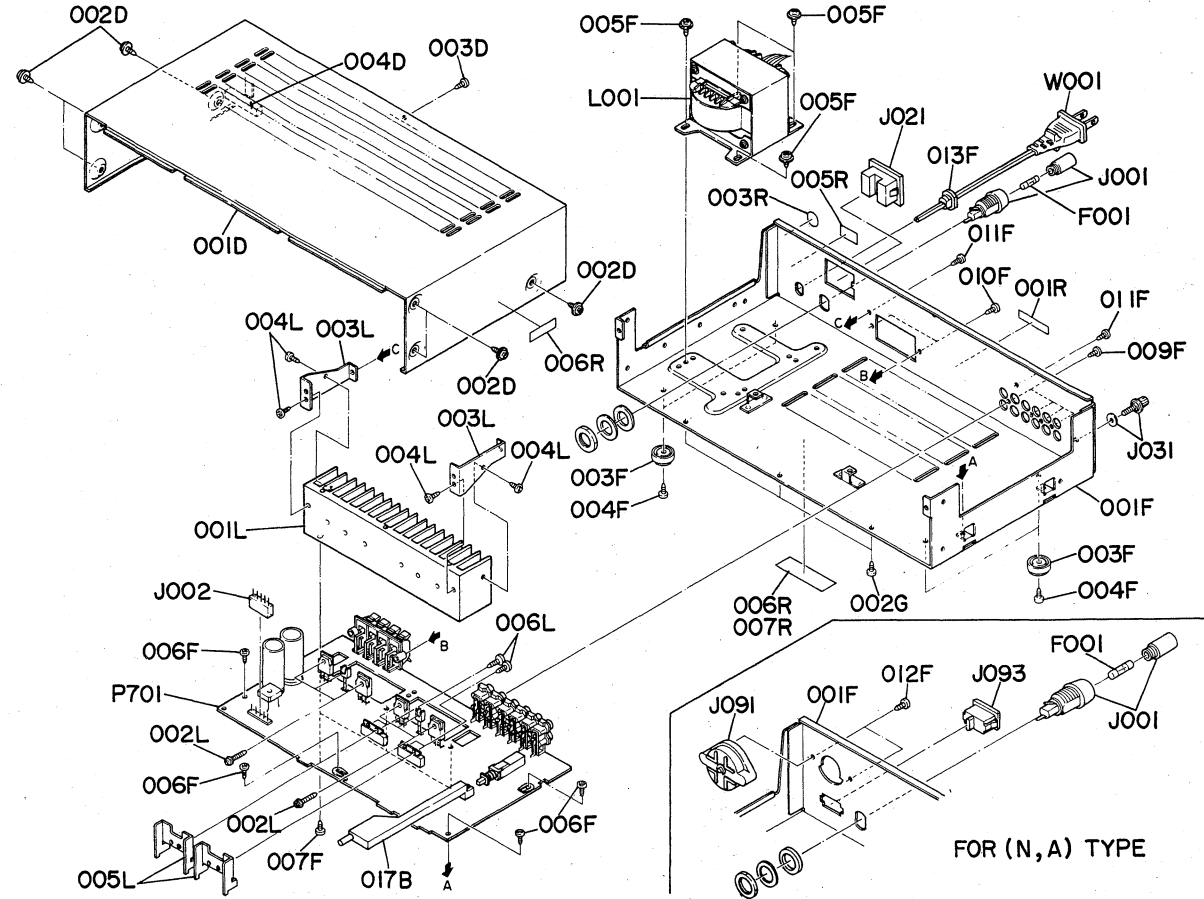

REF. DESIG.	Q'TY			PART NO.	DESCRIPTION
	U	N	A		
001D	1	1	1	261H257010	Lid, Top Cover
002D	6	6	6	51706009U0	SPEC. Set Screw
003D	1	1	1	51280308B0	B.H. Tapped Screw B3 x 8
004D	1			261H056010	Buffer
004D	1	1	1	208H056010	Buffer
001F	1			262H105030	Chassis, Main
001F	1	1	1	262H105020	Chassis, Main
003F	4	4	4	416H057010	Leg
004F	4	4	4	51280408B0	B.H. Tapped Screw B4 x 8
005F	4	4	4	51706009U0	SPEC. Set Screw
006F	4			51280308B0	B.H. Tapped Screw B3 x 8
006F	3	3	3	51280308B0	B.H. Tapped Screw B3 x 8
007F	3	3	3	51280308B0	B.H. Tapped Screw B3 x 8
009F	3	3	3	51280308B0	B.H. Tapped Screw B3 x 8
010F	2	2	2	51280308B0	B.H. Tapped Screw B3 x 8
011F	2	2	2	51280308B0	B.H. Tapped Screw B3 x 8
012F	2	2	2	51280308B0	B.H. Tapped Screw B3 x 8
013F	1			1455259090	Bushing, AC Cord
002G	3	3	3	51280308B0	B.H. Tapped Screw B3 x 8
001L	1	1	1	261H267020	Heatsink
002L	6	6	6	51780312B0	Fin Neck B.T. Screw B3 x 12
003L	2	2	2	261H160010	Bracket, Heatsink
004L	4	4	4	51280308B0	B.H. Tapped Screw B3 x 8
005L	2	2	2	262H267010	Heatsink, IC
006L	4	4	4	51280308B0	B.H. Tapped Screw B3 x 8

REF. DESIG.	Q'TY			PART NO.	DESCRIPTION
	U	N	A		
001R	1			2112265010	Indicator, Serial No.
001R	1	1	1	2112265110	Indicator, Serial No.
003R	1			9511101070	Label, UL
005R	1			2457861040	Label, CSA
006R	2			117H861010	Label
007R	1	1	1	2911861110	Label
ΔF001	1			FS10300500	Fuse 3A
ΔF001	1	1	1	FS10140800	Fuse 1.4A
ΔJ001	1			YJ08000300	Jack, Fuse Holder
ΔJ001	1	1	1	YJ08000290	Jack, Fuse Holder
J002	1	1	1	YJ06001050	Jack, 5P
ΔJ021	1			YJ04001010	Jack, AC Outlet
J031	1	1	1	YL03010250	Terminal, GND
ΔJ091	1	1	1	BY05080050	Voltage Selector
ΔJ093	1	1	1	YP04005080	Plug, AC Inlet
ΔL001	1			TS17629030	Power Transformer
ΔL001	1	1	1	TS18617010	Power Transformer
ΔW001	1			YC01800260	A.C. Power Cord

10. ELECTRICAL PARTS LIST

REF. DESIG.	Q'TY			PART NO.	DESCRIPTION
	U	N	A		
P701	1	1	1	YK262H1610	P701-MAIN AMP CIRCUIT BOARD
	1	1	1	ZZ262H1610	P.W. Board, Main Amp P.W. Board Assembly
P701-CAPACITORS					
C401	1	1	1	DF16103350	Film 0.01 μ F \pm 10%
C402	1	1	1	DF16103350	Film 0.01 μ F \pm 10%
C403	1	1	1	EA47505030	Elect 4.7 μ F 50V
C404	1	1	1	EA47505030	Elect 4.7 μ F 50V
C405	1	1	1	DD15820370	Ceramic 82pF \pm 5%
C406	1	1	1	DD15820370	Ceramic 82pF \pm 5%
C407	1	1	1	DD15681370	Ceramic 680pF \pm 5%
C408	1	1	1	DD15681370	Ceramic 680pF \pm 5%
C409	1	1	1	EA22800630	Elect 2200 μ F 6.3V
C410	1	1	1	EA22800630	Elect 2200 μ F 6.3V
C411	1	1	1	EA22701630	Elect 220 μ F 16V
C412	1	1	1	EA22701630	Elect 220 μ F 16V
C413	1	1	1	DF16473350	Film 0.047 μ F \pm 10%
C414	1	1	1	DF16473350	Film 0.047 μ F \pm 10%
C415	1	1	1	DF16103350	Film 0.01 μ F \pm 10%
C416	1	1	1	DF16103350	Film 0.01 μ F \pm 10%
C417	1	1	1	DF16333350	Film 0.033 μ F \pm 10%
C418	1	1	1	DF16333350	Film 0.033 μ F \pm 10%
C419	1	1	1	EA47505030	Elect 4.7 μ F 50V
C420	1	1	1	EA47505030	Elect 4.7 μ F 50V
C421	1	1	1	DF16472350	Film 4700pF \pm 10%
C422	1	1	1	DF16472350	Film 4700pF \pm 10%
C423	1	1	1	DK18103310	Ceramic 0.01 μ F
C424	1	1	1	DK18103310	Ceramic 0.01 μ F
C701	1	1	1	EA33505030	Elect 3.3 μ F 50V
C702	1	1	1	EA33505030	Elect 3.3 μ F 50V
C703	1	1	1	DD15821370	Ceramic 820pF \pm 5%
C704	1	1	1	DD15821370	Ceramic 820pF \pm 5%
C705	1	1	1	EA10505030	Elect 1 μ F 50V
C706	1	1	1	EA10505030	Elect 1 μ F 50V
C707	1	1	1	EA22605030	Elect 22 μ F 50V
C708	1	1	1	EA22605030	Elect 22 μ F 50V
C709	1	1	1	DD15101370	Ceramic 100pF \pm 5%
C710	1	1	1	DD15101370	Ceramic 100pF \pm 5%
C711	1	1	1	EA10505030	Elect 1 μ F 50V
C712	1	1	1	EA10505030	Elect 1 μ F 50V
C713	1	1	1	DD15150370	Ceramic 15pF \pm 5%
C714	1	1	1	DD15150370	Ceramic 15pF \pm 5%
C715	1	1	1	DF16333350	Film 0.033 μ F \pm 10%
C716	1	1	1	DF16333350	Film 0.033 μ F \pm 10%
C717	1	1	1	DD10050370	Ceramic 5pF \pm 0.25pF
C718	1	1	1	DD10050370	Ceramic 5pF \pm 0.25pF
C719	1	1	1	EA47505030	Elect 4.7 μ F 50V
C720	1	1	1	EA47505030	Elect 4.7 μ F 50V
C721	1	1	1	EA47505030	Elect 4.7 μ F 50V
C722	1	1	1	EA47505030	Elect 4.7 μ F 50V
C723	1	1	1	DF16683350	Film 0.068 μ F \pm 10%
C724	1	1	1	DF16683350	Film 0.068 μ F \pm 10%
C725	1	1	1	DF16683350	Film 0.068 μ F \pm 10%
C726	1	1	1	DF16683350	Film 0.068 μ F \pm 10%

REF. DESIG.	Q'TY			PART NO.	DESCRIPTION
	U	N	A		
C801	1	1	1	EA10701630	Elect 100 μ F 16V
C802	1	1	1	EA10701630	Elect 100 μ F 16V
C803	1	1	1	EB68805060	Elect 6800 μ F 50V
C804	1	1	1	EB68805060	Elect 6800 μ F 50V
C805	1	1	1	DK18103560	Ceramic 0.01 μ F
C806	1	1	1	DK18103560	Ceramic 0.01 μ F
C807	1	1	1	EA33701630	Elect 330 μ F 16V
C808	1	1	1	EA10605030	Elect 10 μ F 50V
C809	1	1	1	EA10701630	Elect 100 μ F 16V
CK01	1	1	1	EA10605030	Elect 10 μ F 50V
CK02	1	1	1	EA22701030	Elect 220 μ F 10V
CK03	1	1	1	EA10605030	Elect 10 μ F 50V
CK04	1	1	1	EA33505030	Elect 3.3 μ F 50V
CK05	1	1	1	EA47506330	Elect 4.7 μ F 63V
CS01	1	1	1	EA33505030	Elect 3.3 μ F 50V
CS02	1	1	1	EA33505030	Elect 3.3 μ F 50V
CS03	1	1	1	DK18103310	Ceramic 0.01 μ F
CS04	1	1	1	EA33505030	Elect 3.3 μ F 50V
CS05	1	1	1	EA33801630	Elect 3300 μ F 16V
CS06	1	1	1	DK18103310	Ceramic 0.01 μ F
CS07	1	1	1	DK18103310	Ceramic 0.01 μ F
CS08	1	1	1	EA10505030	Elect 1 μ F 50V
CV01	1	1	1	EA33505030	Elect 3.3 μ F 50V
CV02	1	1	1	EA33505030	Elect 3.3 μ F 50V
P701-RESISTORS (All Resistors are \pm 5% and $\frac{1}{4}$ W)					
R401	1	1	1	GD05154140	150K Ω
R402	1	1	1	GD05154140	150K Ω
R403	1	1	1	GD05331140	330 Ω
R404	1	1	1	GD05331140	330 Ω
R405	1	1	1	GD05101140	100 Ω
R406	1	1	1	GD05101140	100 Ω
R407	1	1	1	GD05683140	68K Ω
R408	1	1	1	GD05683140	68K Ω
R409	1	1	1	GD05220140	22 Ω
R410	1	1	1	GD05220140	22 Ω
R411	1	1	1	GD05120140	12 Ω
R412	1	1	1	GD05120140	12 Ω
R413	1	1	1	GD05472140	4.7K Ω
R414	1	1	1	GD05472140	4.7K Ω
R415	1	1	1	GD05391140	390 Ω
R416	1	1	1	GD05391140	390 Ω
R417	1	1	1	GD05472140	4.7K Ω
R418	1	1	1	GD05472140	4.7K Ω
R419	1	1	1	GD05472140	4.7K Ω
R420	1	1	1	GD05472140	4.7K Ω
R421	1	1	1	GD05121140	120 Ω
R422	1	1	1	GD05121140	120 Ω
R423	1	1	1	GD05121140	120 Ω
R424	1	1	1	GD05121140	120 Ω
R425	1	1	1	GD05683140	68K Ω
R426	1	1	1	GD05683140	68K Ω
R427	1	1	1	GD05562140	5.6K Ω
R428	1	1	1	GD05562140	5.6K Ω
R429	1	1	1	GG05101140	100 Ω
R430	1	1	1	GG05101140	100 Ω

REF. DESIG.	Q'TY			PART NO.	DESCRIPTION
	U	N	A		
R431	1	1	1	GD05104140	100K Ω
R432	1	1	1	GD05104140	100K Ω
R433	1	1	1	GD05561140	560 Ω
R434	1	1	1	GD05561140	560 Ω
R701	1	1	1	GD05102140	1K Ω
R702	1	1	1	GD05102140	1K Ω
R703	1	1	1	GD05104140	100K Ω
R704	1	1	1	GD05104140	100K Ω
R705	1	1	1	GD05102140	1K Ω
R706	1	1	1	GD05102140	1K Ω
R707	1	1	1	GD05563140	56K Ω
R708	1	1	1	GD05563140	56K Ω
R709	1	1	1	GD05222140	2.2K Ω
R710	1	1	1	GD05222140	2.2K Ω
R711	1	1	1	GD05123140	12K Ω
R712	1	1	1	GD05123140	12K Ω
R713	1	1	1	GD05684140	680K Ω
R714	1	1	1	GD05684140	680K Ω
R715	1	1	1	GG05047140	4.7 Ω
R716	1	1	1	GG05047140	4.7 Ω
R717	1	1	1	GG05047140	4.7 Ω
R718	1	1	1	GG05047140	4.7 Ω
R719	1	1	1	GD05563140	56K Ω
R720	1	1	1	GD05563140	56K Ω
△R721	1	1	1	BW10000040	0.27 Ω 3W x 2, Compo.
△R722	1	1	1	BW10000040	0.27 Ω 3W x 2, Compo.
R723	1	1	1	GD05151140	150 Ω
R724	1	1	1	GD05151140	150 Ω
R725	1	1	1	GD05222140	2.2K Ω
R726	1	1	1	GD05222140	2.2K Ω
R727	1	1	1	GD05122140	1.2K Ω
R728	1	1	1	GD05122140	1.2K Ω
R729	1	1	1	GA05047010	4.7 Ω 1W
R730	1	1	1	GA05047010	4.7 Ω 1W
R731	1	1	1	GD05153140	15K Ω
R732	1	1	1	GD05153140	15K Ω
R733	1	1	1	GA05100020	10 Ω 2W
R734	1	1	1	GA05100020	10 Ω 2W
R735	1	1	1	RA01010600	100 Ω , Trimming
R736	1	1	1	RA01010600	100 Ω , Trimming
△R801	1	1	1	GA05102030	1K Ω 3W
△R802	1	1	1	GA05821030	8.2K Ω 3W
R803	1	1	1	GA05182020	1.8K Ω 2W
R804	1	1	1	GD05471140	470 Ω
R807	1	1	1	GA05182020	1.8K Ω 2W
RK01	1	1	1	GD05123140	12K Ω
RK02	1	1	1	GD05222140	2.2K Ω
RK03	1	1	1	GD05123140	12K Ω
RK04	1	1	1	GD05564140	560K Ω
RK05	1	1	1	GD05333140	33K Ω
RK06	1	1	1	GD05563140	56K Ω
RK07	1	1	1	GD05101140	100 Ω
RK08	1	1	1	GD05223140	22K Ω
RK09	1	1	1	GD05103140	10K Ω
RK10	1	1	1	RF05100140	10 Ω , Fusible

REF. DESIG.	Q'TY			PART NO.	DESCRIPTION
	U	N	A		
RS01	1	1	1	GD05472140	4.7K Ω
RS02	1	1	1	GD05472140	4.7K Ω
RS03	1	1	1	GD05104140	100K Ω
RS04	1	1	1	GD05224140	220K Ω
RS05	1	1	1	GD05332140	3.3K Ω
RV01	1	1	1	GD05102140	1K Ω
RV02	1	1	1	GD05102140	1K Ω
RV03	1	1	1	GD05105140	1M Ω
RV04	1	1	1	GD05105140	1M Ω
RV05	1	1	1	GD05102140	1K Ω
RV06	1	1	1	GD05102140	1K Ω
RV07	1	1	1	GD05105140	1M Ω
RV08	1	1	1	GD05105140	1M Ω
RV09	1	1	1	GD05221140	220 Ω
RV10	1	1	1	GD05221140	220 Ω
RV11	1	1	1	GD05102140	1K Ω
RV12	1	1	1	GD05102140	1K Ω
RV13	1	1	1	GD05105140	1M Ω
RV14	1	1	1	GD05105140	1M Ω
RV15	1	1	1	GD05102140	1K Ω
RV16	1	1	1	GD05102140	1K Ω
RV17	1	1	1	GD05105140	1M Ω
RV18	1	1	1	GD05105140	1M Ω
P701-SEMICONDUCTORS					
D401	1	1	1	HD20001000	Diode 1S1555
D402	1	1	1	HD20001000	Diode 1S1555
D701	1	1	1	HD20001000	Diode 1S1555
D702	1	1	1	HD20001000	Diode 1S1555
D703	1	1	1	HD20001000	Diode 1S1555
D704	1	1	1	HD20001000	Diode 1S1555
D705	1	1	1	HV00009080	Varistor STV3H(O,Y)
D706	1	1	1	HV00009080	Varistor STV3H(O,Y)
D707	1	1	1	HD20011010	Diode W06C
D708	1	1	1	HD20011010	Diode W06C
D709	1	1	1	HD20011010	Diode W06C
D710	1	1	1	HD20011010	Diode W06C
D801	1	1	1	HD30038010	Zener HZ9C1L
D802	1	1	1	HD30038010	Zener HZ9C1L
△D803	1	1	1	HD20022030	Diode DSF10C
△D804	1	1	1	HD20022030	Diode DSF10C
△D805	1	1	1	HD20008290	Diode S4VB20
D806	1	1	1	HD30026020	Zener MA1075H
DK01	1	1	1	HD20001000	Diode 1S1555
DK02	1	1	1	HD30023010	Zener HZ6C1L
DK03	1	1	1	HD20002210	Diode 1S2472
△DK04	1	1	1	HD20002230	Diode DSF10C
DS01	1	1	1	HD20001000	Diode 1S1555
DS02	1	1	1	HD30045010	Zener HZ9C1L
Q401	1	1	1	HF203691G0	F.E.T. 2SK369(GR)
Q402	1	1	1	HF203691G0	F.E.T. 2SK369(GR)
Q403	1	1	1	HF203691G0	F.E.T. 2SK369(GR)
Q404	1	1	1	HF203691G0	F.E.T. 2SK369(GR)
Q405	1	1	1	HC10008090	IC 4558DD

REF. DESIG.	Q'TY			PART NO.	DESCRIPTION
	U	N	A		
Q701	1	1	1	HT413022B0	Transistor 2SD1302(S,T)
Q702	1	1	1	HT413022B0	Transistor 2SD1302(S,T)
△Q703	1	1	1	HC10097060	IC μ PC1270H
△Q704	1	1	1	HC10097060	IC μ PC1270H
△Q705	1	1	1	HT325802A0	Transistor 2SC2580(O,Y)
△Q706	1	1	1	HT325802A0	Transistor 2SC2580(O,Y)
△Q707	1	1	1	HT111052A0	Transistor 2SA1105(O,Y)
△Q708	1	1	1	HT111052A0	Transistor 2SA1105(O,Y)
Q709	1	1	1	HT327851B0	Transistor 2SC2785(J, H)
Q710	1	1	1	HT327851B0	Transistor 2SC2785(J, H)
△Q801	1	1	1	HT205072Q0	Transistor 2SB507(E, F)
QK01	1	1	1	HT327852B0	Transistor 2SC2785(J,H)
QK02	1	1	1	HT111752B0	Transistor 2SA1175(J,H)
QK03	1	1	1	HT327852B0	Transistor 2SC2785(J,H)
QK04	1	1	1	HT327852B0	Transistor 2SC2785(J,H)
QK05	1	1	1	HT111752B0	Transistor 2SA1175(J,H)
QS01	1	1	1	HC10110030	IC LC7815H
QS02	1	1	1	HC406603C0	IC LC4066B-H
P701-MISCELLANEOUS					
J401	1	1	1	YL01010110	Terminal, Earth
J701	1	1	1	YT03080020	Terminal, Speaker
J702	1	1	1	YJ06002430	Jack, 3P
J703	1	1	1	YL01010110	Terminal, Earth
J801	1	1	1	YP06001050	Plug, 5P
JV01	1			YT02020290	Terminal, RCA Jack; 4P
JV01		1	1	YT02040470	Terminal, RCA Jack; 4P
JV02	1			YT02060180	Terminal, RCA Jack; 4P
JV02		1	1	YT02040470	Terminal, RCA Jack; 4P
JV03	1	1	1	YT02040470	Terminal, RCA Jack; 4P
JS01	1	1	1	YJ06002430	Jack, 3P
JS02	1	1	1	YJ06002460	Jack, 7P
JS03	1	1	1	YJ06002270	Jack, 8P
L701	1	1	1	LL23905120	Coil, 1 μ H
L702	1	1	1	LL23905120	Coil, 1 μ H
S401	1	1	1	SP04010470	Push Switch, Phono MM/MC
W701	1	1	1	YU02220260	Jumper Lead, 2P
W702	1	1	1	YU03300260	Jumper Lead, 3P
W703	1	1	1	YU03140260	Jumper Lead, 3P
W704	1	1	1	YU04140260	Jumper Lead, 4P
PE01-VOLUME CIRCUIT BOARD					
PE01	1	1	1	YK262H1620	P.W. Board, Volume
	1	1	1	ZZ262H1620	P.W. Board Assembly
PE01-CAPACITORS					
CE01	1	1	1	EA47505030	Elect 4.7 μ F 50V
CE02	1	1	1	EA47505030	Elect 4.7 μ F 50V
CE03	1	1	1	EA22602530	Elect 22 μ F 25V
CE04	1	1	1	EA22602530	Elect 22 μ F 25V
CE05	1	1	1	DD15220370	Ceramic 22pF \pm 5%
CE06	1	1	1	DD15220370	Ceramic 22pF \pm 5%
CE07	1	1	1	EA22601630	Elect 22 μ F 16V
CE08	1	1	1	EA22601630	Elect 22 μ F 16V
CE09	1	1	1	EA47505030	Elect 4.7 μ F 50V
CE10	1	1	1	EA47505030	Elect 4.7 μ F 50V

REF. DESIG.	Q'TY			PART NO.	DESCRIPTION
	U	N	A		
CE11	1	1	1	DF16472350	Film 4700pF \pm 10%
CE12	1	1	1	DF16472350	Film 4700pF \pm 10%
CE13	1	1	1	DF16183350	Film 0.018 μ F \pm 10%
CE14	1	1	1	DF16183350	Film 0.018 μ F \pm 10%
CE15	1	1	1	DF16823350	Film 0.082 μ F \pm 10%
CE16	1	1	1	DF16823350	Film 0.082 μ F \pm 10%
CE17	1	1	1	EA33405030	Elect 0.33 μ F 50V
CE18	1	1	1	EA33405030	Elect 0.33 μ F 50V
CE19	1	1	1	EA10505030	Elect 1 μ F 50V
CE20	1	1	1	EA10505030	Elect 1 μ F 50V
CE21	1	1	1	EA47505030	Elect 4.7 μ F 50V
CE22	1	1	1	EA47505030	Elect 4.7 μ F 50V
CE23	1	1	1	DF16183350	Film 0.018 μ F \pm 10%
CE24	1	1	1	DF16183350	Film 0.018 μ F \pm 10%
CE25	1	1	1	DD15331370	Ceramic 330pF \pm 5%
CE26	1	1	1	DD15331370	Ceramic 330pF \pm 5%
CE27	1	1	1	DF16683350	Film 0.068 μ F \pm 10%
CE28	1	1	1	DF16683350	Film 0.068 μ F \pm 10%
CE29	1	1	1	DD15220370	Ceramic 22pF \pm 5%
CE30	1	1	1	DD15220370	Ceramic 22pF \pm 5%
PE01-RESISTORS					
(All Resistors are \pm 5% and $\frac{1}{4}$ W)					
RE01	1	1	1	GD05104140	100K Ω
RE02	1	1	1	GD05104140	100K Ω
RE03	1	1	1	GD05223140	22K Ω
RE04	1	1	1	GD05223140	22K Ω
RE05	1	1	1	GD05104140	100K Ω
RE06	1	1	1	GD05104140	100K Ω
RE07	1	1	1	GD05103140	10K Ω
RE08	1	1	1	GD05103140	10K Ω
RE09	1	1	1	GG05101140	100 Ω
RE10	1	1	1	GG05101140	100 Ω
RE11	1	1	1	GD05331140	330 Ω
RE12	1	1	1	GD05331140	330 Ω
RE13	1	1	1	GD05331140	330 Ω
RE14	1	1	1	GD05331140	330 Ω
RE15	1	1	1	GD05104140	100K Ω
RE16	1	1	1	GD05104140	100K Ω
RE17	1	1	1	GD05333140	33K Ω
RE18	1	1	1	GD05333140	33K Ω
RE19	1	1	1	GD05183140	18K Ω
RE20	1	1	1	GD05183140	18K Ω
RE21	1	1	1	RS05030520	50K Ω (B), Variable
RE22	1	1	1	RS05030520	50K Ω (B), Variable
RE23	1	1	1	RS05030520	50K Ω (B), Variable
RE24	1	1	1	RS05030520	50K Ω (B), Variable
RE25	1	1	1	RS05030520	50K Ω (B), Variable
RE26	1	1	1	RM01040840	100K Ω (B), Variable
RE27	1	1	1	RX02040080	200K Ω (W), Variable
RY01	1	1	1	GD05471140	470 Ω
RY02	1	1	1	GD05104140	100K Ω
RY03	1	1	1	GD05471140	470 Ω
RY04	1	1	1	GD05104140	100K Ω
RY05	1	1	1	GD05471140	470 Ω
RY06	1	1	1	GD05104140	100K Ω
RY07	1	1	1	GD05471140	470 Ω
RY08	1	1	1	GD05104140	100K Ω
RY09	1	1	1	GD05471140	470 Ω
RY10	1	1	1	GD05104140	100K Ω

REF. DESIG.	Q'TY			PART NO.	DESCRIPTION
	U	N	A		
PE01-SEMICONDUCTORS					
QE01	1	1	1	HC10108030	IC STK6325A
QE02	1	1	1	HC10108030	IC STK6325A
QE03	1	1	1	HC10008090	IC 4558DD
QY01 ?	5	5	5	HT111752B0	Transistor 2SA1175(J, H)
QY05					
PE01-MISCELLANEOUS					
SE01	1	1	1	SPO2011090	Push Switch, Loudness
SE02	1	1	1	SPO2011090	Push Switch, Low Filter
SY01	1	1	1	SP01010840	Push Switch, Tape 1
SY02	1	1	1	SP01010840	Push Switch, Phono
SY03	1	1	1	SP01010840	Push Switch, Tape 2
SY04	1	1	1	SP01010840	Push Switch, CD
SY05	1	1	1	SP01010840	Push Switch, Tuner
VY01 ?	5	5	5	IN10080620	Lamp
VY05					
WE01	1	1	1	YU03160260	Jumper Lead, 3P
WE02	1	1	1	YU03240260	Jumper Lead, 3P
WY01	1	1	1	YU07160260	Jumper Lead, 7P
WY02	1	1	1	YU08160260	Jumper Lead, 8P
PN01-SPEAKER SWITCH CIRCUIT BOARD					
PN01	1	1	1	YK262H1630	P.W. Board, Speaker Switch
	1	1	1	ZZ262H1630	P.W. Board Assembly
SN01	1	1	1	SP04020440	Push Switch, Speaker-1.
SN02	1	1	1	SP04020440	Push Switch, Speaker-2
WN01	1	1	1	YU03120260	Jumper Lead, 3P
PP01-POWER SWITCH CIRCUIT BOARD					
PP01	1	1	1	YK262H1640	P.W. Board, Power Switch
	1	1	1	ZZ262H1640	P.W. Board Assembly
△G001	1	1	1	DK18103840	Ceramic Cap. 0.01μF 250V
△S001	1	1	1	SP01010650	Push Switch, Power

REF. DESIG.	Q'TY			PART NO.	DESCRIPTION
	U	N	A		
PW01-HEADPHONE JACK CIRCUIT BOARD					
PW01	1	1	1	YK262H1650	P.W. Board, Headphone Jack
	1	1	1	ZZ262H1650	P.W. Board Assembly
RW01	1	1	1	GA05331010	Resistor 330Ω ±5% 1W
RW02	1	1	1	GA05331010	Resistor 330Ω ±5% 1W
JW01	1	1	1	YJ01001790	Jack, Headphone
PX01-SPEAKER LAMP CIRCUIT BOARD					
PX01	1	1	1	YK262H1660	P.W. Board, Speaker Lamp
	1	1	1	ZZ262H1660	P.W. Board Assembly
VX01	1	1	1	IN10080620	Lamp 8V 50mA
VX02	1	1	1	IN10080620	Lamp 8V 50mA

(W01-99)	Assembly and Wiring
(T01-99)	Adjustment
(X01-00)	Correction

NOTE ON SAFETY:

Symbol △ Fire or electrical shock hazard. Only original parts should be used to replace any part marked with symbol △. Any other component substitution (other than original type); may increase risk of fire or electrical shock hazard.

11. TECHNICAL SPECIFICATIONS

AUDIO SECTION

POWER OUTPUT PER CHANNEL

DIN 4 OHMS	70 W
RMS 4 OHMS	65 W
DIN 8 OHMS	60 W
RMS 8 OHMS	50 W
TOTAL HARMONIC DISTORTION AT RMS 8 OHMS	0.05%
I.M. DISTORTION	0.05%
DAMPING FACTOR 8 OHMS (1 kHz)	55

MM CARTRIDGE INPUT

Frequency Response (RIAA) 20 Hz – 20 kHz	±0.5 dB
Signal-to-Noise Ratio	80 dB
Input Impedance	47 k ohms
Input Capacitance	100 pF
Input Sensitivity	2.5 mV

MC CARTRIDGE INPUT

Input Sensitivity	250 μ V
Input Impedance	100 ohms

AUX. INPUT

Input Impedance	25 k ohms
Input Sensitivity	150 mV
Frequency Response (\pm 2 dB)	10 Hz – 50 kHz
Signal-to-Noise Ratio	93 dB

OUTPUT VOLTAGE

Tape Out (Input 7.75 mV)	417 mV
--------------------------	--------

OUTPUT IMPEDANCE

Tape Out	300 ohms
----------	----------

GENERAL

Power Requirements	110/120/220/240V AC, 50/60 Hz
Power Consumption at Rated Output, both Channels Operating	240 W
Dimensions	
Panel Width	416 mm
Panel Height	85 mm
Depth	225 mm
Weight	
Unit Alone	5.3 kg

12. SCHEMATIC DIAGRAM

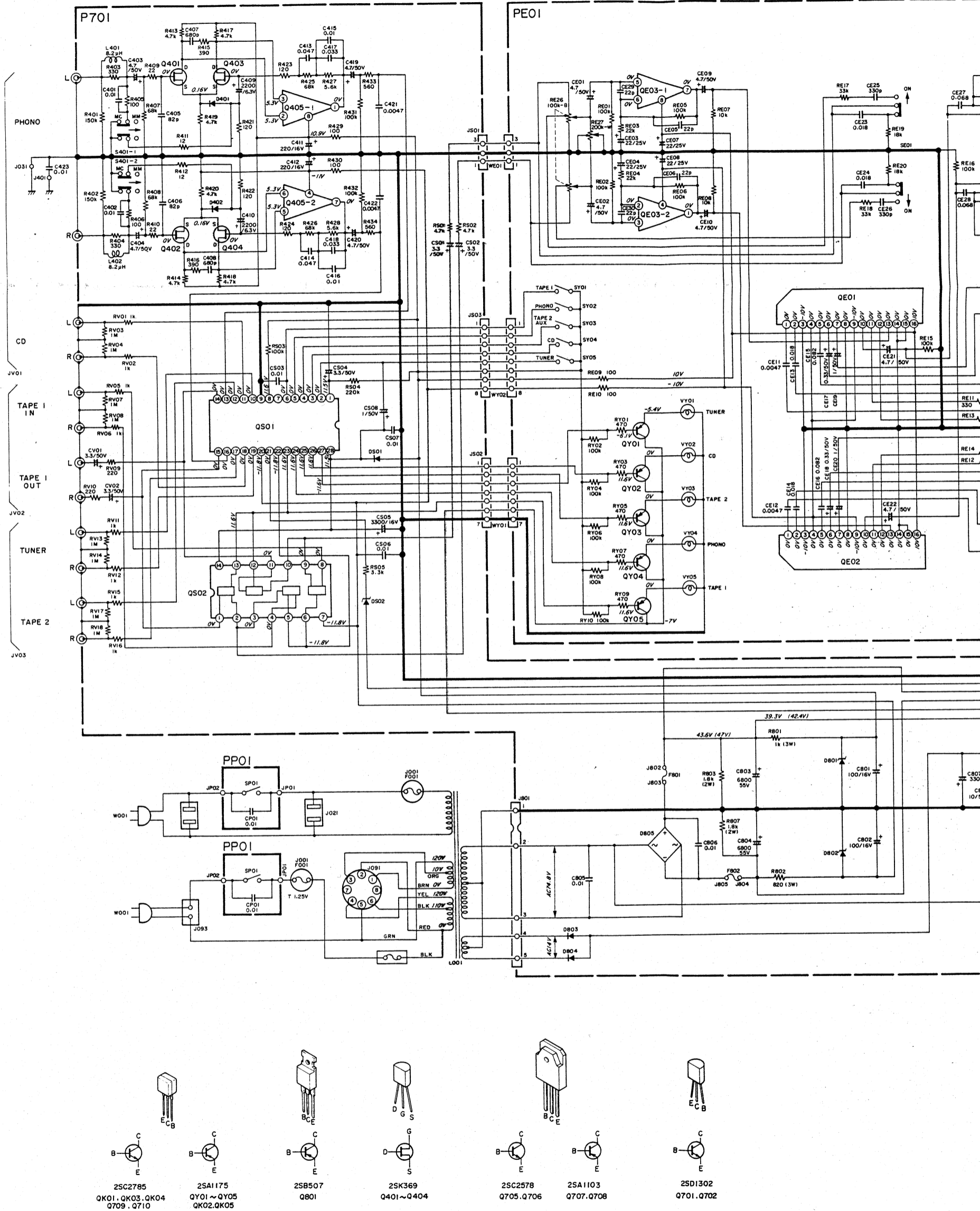

NOTE ON SAFETY:

Symbol Δ Fire or electrical shock hazard. Only original parts should be used to replace any part marked with symbol Δ . Any other component substitution (other than original type); may increase risk of fire or electrical shock hazard.

Model PM440

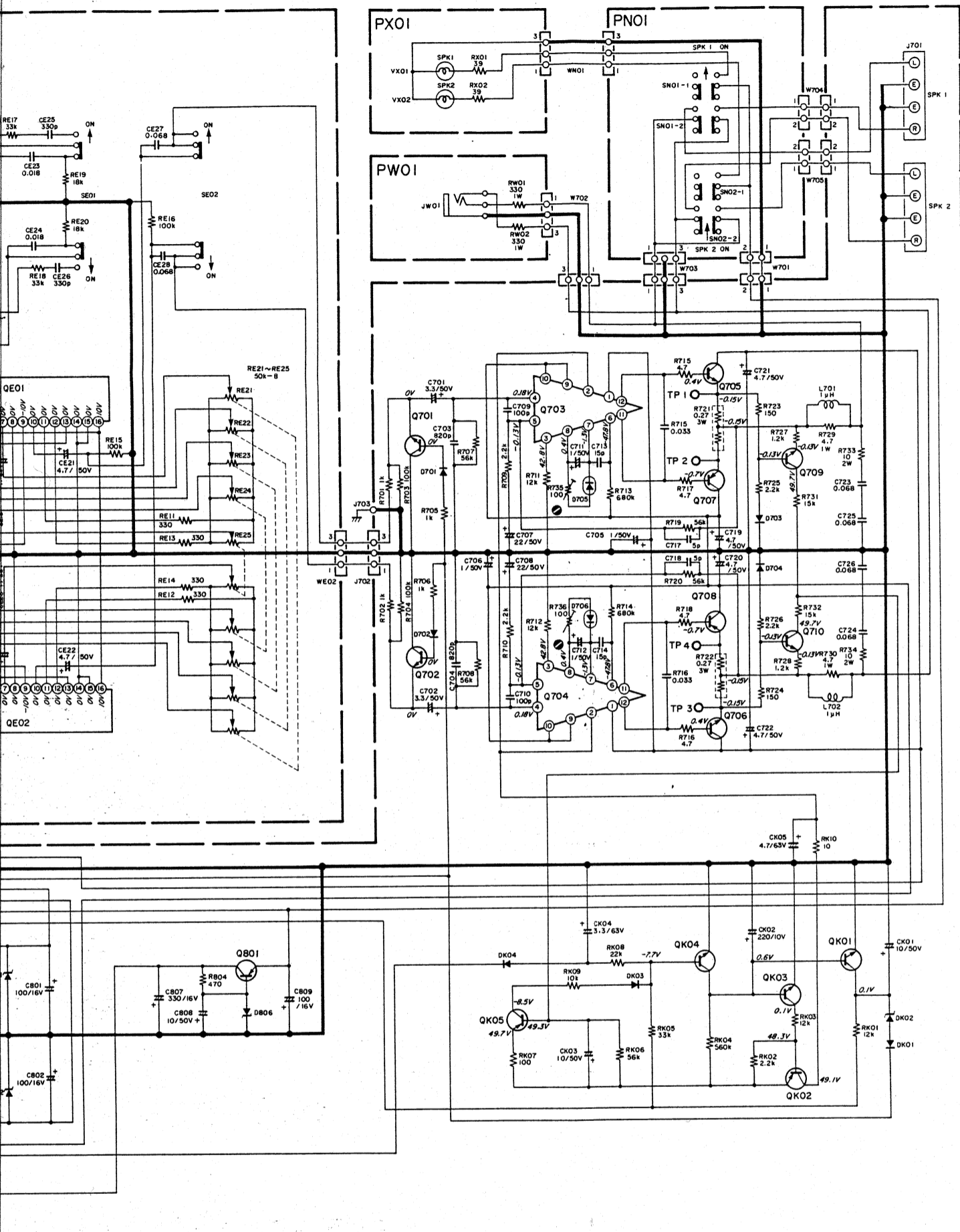

- QE01, QE02
HC10108030
STK-6325A
- QE03, Q405
HC10008090
NJM4558D-D
- QY01~QY05, QK02, QK05
HT111752B
2SA1175
- QK01, QK03, QK04, Q709, Q710
HT327852B0
2SC2785
- QS01
HC10110030
LC7815H
- QS02
HC406603C0
LC4066B-H
- Q401~Q404
HF203691G0
2SK369
- Q701, Q702
HT413022B0
2SD1302
- Q703, Q704
HC10097060
μPC1270H
- Q705, Q706
HT325802A0
2SC2578
- Q707, Q708
HT111052A0
2SA1103
- Q801
HT205072Q0
2SB507
- DK01, DS01, D401, D402, D701~D704
HD20001000
1S1555
- DK02, D808
HD30045010
HZ6C
- DK03, D801, D802
HD30038010
1S2472
- DK04
HD20022030
DSF10C
- D705, D706
HV00009080
STV3H
- D805
HD20008290
S4VB
- D806, D807
HD30026020
DS135D
- DS02
HD30045010
HZ9CIL

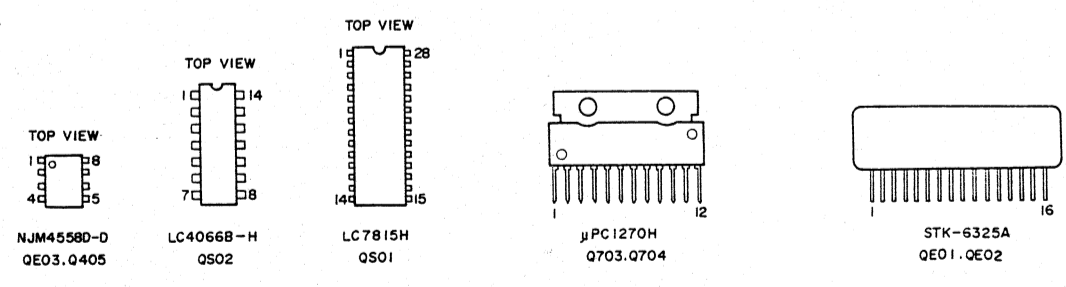

Components and wiring are subject to change for modification without notice.