

C 356BEE

**STEREO
AMPLIFIER**

SERVICE MANUAL

C 356BEE

**STEREO
AMPLIFIER**



TABLE OF CONTENTS

DESCRIPTION	PAGE
SERVICE CAUTION.....	3-4
REAR PANEL/FRONT PANEL VIEW.....	5-6
SPECIFICATIONS.....	7-8
WIRING DIAGRAM.....	9
BLOCK DIAGRAM.....	10-13
ALIGNMENT PROCEDURE.....	14
SCHEMATICS.....	15-18
PCB LAYOUT.....	19-24
TROUBLE SHOOTING GUIDE.....	25
ELECTRICAL PARTS LIST.....	26-36
EXPLODED VIEW.....	37
EXPLODED VIEW PARTS LIST.....	38

PRODUCT SAFETY SERVICING GUIDELINES

CAUTION : DO NOT ATTEMPT TO MODIFY THIS PRODUCT IN ANY WAY. NEVER PERFORM CUSTOMIZED INSTALLATIONS WITHOUT MANUFACTURER'S APPROVAL. UNAUTHORIZED MODIFICATIONS WILL NOT ONLY VOID THE WARRANTY, BUT MAY LEAD TO YOUR BEING LIABLE FOR ANY RESULTING PROPERTY DAMAGE OR USER INJURY.

SERVICE WORK SHOULD BE PERFORMED ONLY AFTER YOU ARE THOROUGHLY FAMILIAR WITH ALL OF THE FOLLOWING SAFETY CHECKS AND SERVICING GUIDELINES. TO DO OTHERWISE, INCREASES THE RISK OF POTENTIAL HAZARDS AND INJURY TO THE USER.

WHILE SERVICING, USE AN ISOLATION TRANSFORMER FOR PROTECTION FROM AC LINE SHOCK.

SAFETY CHECKS

AFTER THE ORIGINAL SERVICE PROBLEM HAS BEEN CORRECTED. A CHECK SHOULD BE MADE OF THE FOLLOWING.

SUBJECT : FIRE & SHOCK HAZARD

1. BE SURE THAT ALL COMPONENTS ARE POSITIONED IN SUCH A WAY AS TO AVOID POSSIBILITY OF ADJACENT COMPONENT SHORTS. THIS IS ESPECIALLY IMPORTANT ON THOSE MODULES WHICH ARE TRANSPORTED TO AND FROM THE REPAIR SHOP.
2. NEVER RELEASE A REPAIR UNLESS ALL PROTECTIVE DEVICES SUCH AS INSULATORS, BARRIERS, COVERS, SHIELDS, STRAIN RELIEFS, POWER SUPPLY CORDS, AND OTHER HARDWARE HAVE BEEN REINSTALLED PER ORIGINAL DESIGN. BE SURE THAT THE SAFETY PURPOSE OF THE POLARIZED LINE PLUG HAS NOT BEEN DEFEATED.
3. SOLDERING MUST BE INSPECTED TO DISCOVER POSSIBLE COLD SOLDER JOINTS, SOLDER SPLASHES OR SHARP SOLDER POINTS. BE CERTAIN TO REMOVE ALL LOOSE FOREIGN PARTICLES.
4. CHECK FOR PHYSICAL EVIDENCE OF DAMAGE OR DETERIORATION TO PARTS AND COMPONENTS. FOR FRAYED LEADS, DAMAGED INSULATION (INCLUDING AC CORD). AND REPLACE IF NECESSARY FOLLOW ORIGINAL LAYOUT, LEAD LENGTH AND DRESS.
5. NO LEAD OR COMPONENT SHOULD TOUCH A RECEIVING TUBE OR A RESISTOR RATED AT 1 WATT OR MORE. LEAD TENSION AROUND PROTRUDING METAL SURFACES MUST BE AVOIDED.
6. ALL CRITICAL COMPONENTS SUCH AS FUSES, FLAMEPROOF RESISTORS, CAPACITORS, ETC. MUST BE REPLACED WITH EXACT FACTORY TYPES, DO NOT USE REPLACEMENT COMPONENTS OTHER THAN THOSE SPECIFIED OR MAKE UNRECOMMENDED CIRCUIT MODIFICATIONS.
7. AFTER RE-ASSEMBLY OF THE SET ALWAYS PERFORM AN AC LEAKAGE TEST ON ALL EXPOSED METALLIC PARTS OF THE CABINET, (THE CHANNEL SELECTOR KNOB, ANTENNA TERMINALS. HANDLE AND SCREWS) TO BE SURE THE SET IS SAFET TO OPERATE WITHOUT DANGER OF ELECTRICAL SHOCK. DO NOT USE A LINE ISOLATION TRANSFORMER DURING THIS TEST USE AN AC VOLTMETER, HAVING 5000 OHMS PER VOLT OR MORE SENSITIVITY, IN THE FOLLOWING MANNER; CONNECT A 1500 OHM 10 WATT RESISTOR, PARALLELED BY A .15 MFD, 150V AC TYPE CAPACITOR BETWEEN A KNOWN GOOD EARTH GROUND (WATER PIPE, CONDUIT, ETC.) AND THE EXPOSED METALLIC PARTS, ONE AT A TIME.
MEASURE THE AC VOLTAGE ACROSS THE COMBINATION OF 1500 OHM RESISTOR AND .15 MFD CAPACITOR.
REVERSE THE AC PLUG AND REPEAT AC VOLTAGE MEASUREMENTS FOR EACH EXPOSED METALLIC PART.

VOLTAGE MEASURE MUST NOT EXCEED 75 VOLTS R.M.S. THIS CORRESPONDS TO 0.5 MILLIAMP AC ANY VALUE EXCEEDING THIS LIMIT CONSTITUTES A POTENTIAL SHOCK HAZARD AND MUST BE CORRECTED IMMEDIATELY.

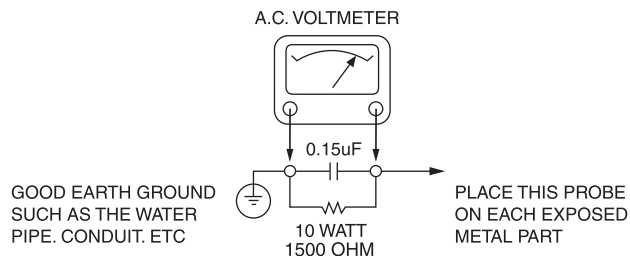

SUBJECT : GRAPHIC SYMBOLS



THE LIGHTNING FLASH WITH ARROWHEAD SYMBOL, WITHIN AN EQUILATERAL TRIANGLE, IS INTENDED TO ALERT THE USER TO THE PRESENCE OF UNINSULATED "DANGEROUS VOLTAGE" WITHIN THE PRODUCT'S ENCLOSURE THAT MAY BE OF SUFFICIENT MAGNITUDE TO CONSTITUTE A RISK OF ELECTRIC SHOCK.



THE EXCLAMATION POINT WITHIN AN EQUILATERAL TRIANGLE IS INTENDED TO ALERT THE USER TO THE PRESENCE OF IMPORTANT OPERATING AND MAINTENANCE (SERVICING) INSTRUCTIONS IN THE LITERATURE ACCOMPANYING THE APPLIANCE.

SUBJECT : TIPS ON PROPER INSTALLATION

1. NEVER INSTALL ANY PRODUCT IN A CLOSED-IN RECESS, CUBBYHOLE OR CLOSELY FITTING SHELF SPACE. OVER OR CLOSE TO HEAT DUCT, OR IN THE PATH OF HEATED AIR FLOW.
2. AVOID CONDITIONS OF HIGH HUMIDITY SUCH AS: OUTDOOR PATIO INSTALLATIONS WHERE DEW IS A FACTOR, NEAR STEAM RADIATORS WHERE STEAM LEAKAGE IS A FACTOR, ETC.
3. AVOID PLACEMENT WHERE DRAPERIES MAY OBSTRUCT REAR VENTING. THE CUSTOMER SHOULD ALSO AVOID THE USE OF DECORATIVE SCARVES OR OTHER COVERINGS WHICH MIGHT OBSTRUCT VENTILATION.
4. WALL AND SHELF MOUNTED INSTALLATIONS USING A COMMERCIAL MOUNTING KIT MUST FOLLOW THE FACTORY APPROVED MOUNTING INSTRUCTIONS A PRODUCT MOUNTED TO A SHELF OR PLATFORM MUST RETAIN ITS ORIGINAL FEET (OR THE EQUIVALENT THICKNESS IN SPACERS) TO PROVIDE ADEQUATE AIR FLOW ACROSS THE BOTTOM, BOLTS OR SCREWS USED FOR FASTENERS MUST NOT TOUCH ANY PARTS OR WIRING. PERFORM LEAKAGE TEST ON CUSTOMIZED INSTALLATIONS.
5. CAUTION CUSTOMERS AGAINST THE MOUNTING OF A PRODUCT ON SLOPING SHELF OR A TILTED POSITION, UNLESS THE PRODUCT IS PROPERLY SECURED.
6. A PRODUCT ON A ROLL-ABOUT CART SHOULD BE STABLE ON ITS MOUNTING TO THE CART. CAUTION THE CUSTOMER ON THE HAZARDS OF TRYING TO ROLL A CART WITH SMALL CASTERS ACROSS THRESHOLDS OR DEEP PILE CARPETS.
7. CAUTION CUSTOMERS AGAINST THE USE OF A CART OR STAND WHICH HAS NOT BEEN LISTED BY UNDERWRITERS LABORATORIES, INC. FOR USE WITH THEIR SPECIFIC MODEL OF TELEVISION RECEIVER OR GENERICALLY APPROVED FOR USE WITH T.V.'S OF THE SAME OR LARGER SCREEN SIZE.
8. CAUTION CUSTOMERS AGAINST THE USE OF EXTENSION CORDS, EXPLAIN THAT A FOREST OF EXTENSIONS SPROUTING FROM A SINGLE OUTLET CAN LEAD TO DISASTROUS CONSEQUENCES TO HOME AND FAMILY.

SERVICING PRECAUTIONS

CAUTION : Before servicing the A/V Receiver covered by this service data and its supplements and addends, read and follow the **SAFETY PRECAUTIONS**. **NOTE** : if unforeseen circumstances create conflict between the following servicing precautions and any of the safety precautions in this publication, always follow the safety precautions.

Remember Safety First:

General Servicing Precautions

1. Always unplug the A/V Receiver AC power cord from the AC power source before:
 - (1) Removing or reinstalling any component, circuit board, module, or any other assembly.
 - (2) Disconnecting or reconnecting any internal electrical plug or other electrical connection.
 - (3) Connecting a test substitute in parallel with an electrolytic capacitor.**Caution** : A wrong part substitution or incorrect polarity installation of electrolytic capacitors may result in an explosion hazard.
2. Do not spray chemicals on or near this A/V Receiver or any of its assemblies.
3. Unless specified otherwise in this service data, clean electrical contacts by applying an appropriate contact cleaning solution to the contacts with a pipe cleaner, cottontipped swab, or comparable soft applicator.
Unless specified otherwise in this service data, lubrication of contacts is not required.
4. Do not defeat any plug/socket B+ voltage interlocks with which instruments covered by this service manual might be equipped.
5. Do not apply AC power to this A/V Receiver and/or any of its electrical assemblies unless all solid-state device heat sinks are correctly installed.
6. Always connect test instrument ground lead to the appropriate ground before connecting the test instrument positive lead. Always remove the test instrument ground lead last.

Insulation Checking Procedure

Disconnect the attachment plug from the AC outlet and turn the power on. Connect an insulation resistance meter(500V) to the blades of the attachment plug. The insulation resistance between each blade of the attachment plug and accessible conductive parts (Note 1) should be more than 1M-ohm.

Note 1 : Accessible Conductive Parts including Metal panels, Input terminals, Earphone jacks, etc.

Electrostatically Sensitive (ES) Devices

Some semiconductor (solid state) devices can be damaged easily by static electricity. Such components commonly are called Electrostatically Sensitive (ES) Devices. Examples of typical Es devices are integrated circuits and some field effect transistors and semiconductor chip components.

The following techniques should be used to help reduce the incidence of component damage caused by static electricity.

1. Immediately before handling any semiconductor component or semiconductor-equipped assembly, drain off any electrostatic charge on your body by touching a known earth ground. Alternatively, obtain and wear a commercially available discharging wrist strap device, which should be removed for potential shock reasons prior to applying power to the unit under test.
2. After removing an electrical assembly equipped with ES devices, place the assembly on a conductive surface such as aluminum foil, to prevent electrostatic charge buildup or exposure of the assembly.
3. Use only a grounded-tip soldering iron to solder or unsolder ES devices.
4. Use only an antistatic solder removal device. Some solder removal devices not classified a "anti-static" can generate electrical charges sufficient to damage ES devices.
5. Do not use freonpropelled chemicals. These can generate electrical charge sufficient to damage ES devices.
6. Do not remove a replacement ES device from its protective package until immediately before you are ready to install it. (Most replacement ES devices are packaged with leads electrically shorted together by conductive foam, aluminum foil, or comparable conductive material).
7. Immediately before removing the protective material from the leads of a replacement ES device, touch the protective material to the chassis or circuit assembly into which the device will be installed.

Caution : Be sure no power is applied to the chassis or circuit, and observe all other safety precautions.

8. Minimize bodily motions when handing unpackaged replacement ES devices. (Normally harmless motion such as the brushing together of your clothes fabric or the lifting of your foot from a carpeted floor can generate static electricity sufficient to damage an ES device.)

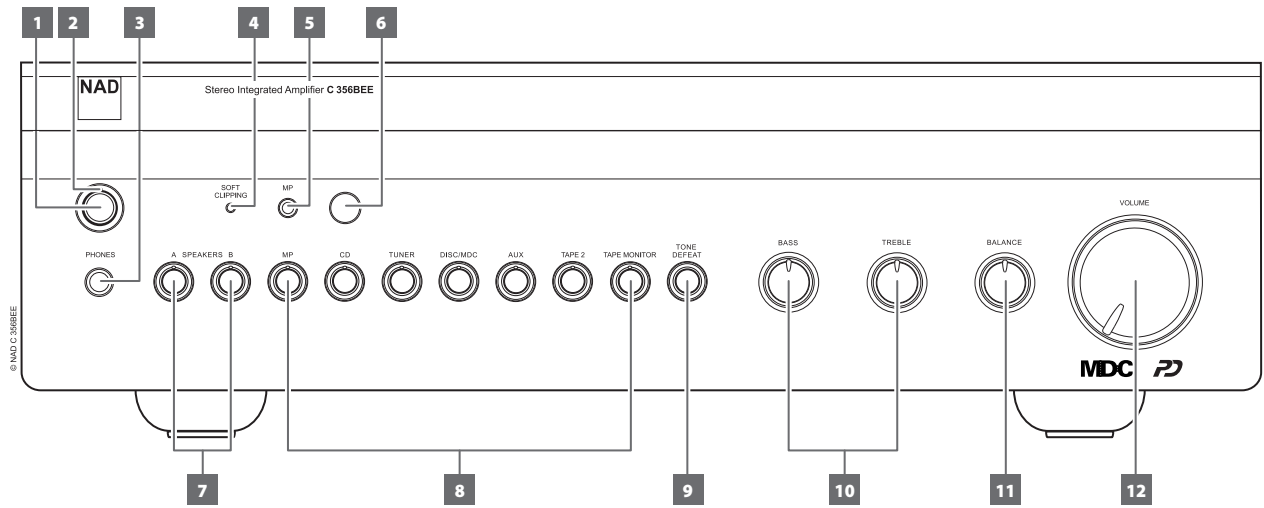

1 STANDBY BUTTON

2 STANDBY LED

3 PHONES:

4 SOFT CLIPPING INDICATOR

5 MP SOCKET

6 REMOTE SENSOR:

7 SPEAKERS

8 INPUT SELECTORS:

9 TONE DEFEAT

10 TONE CONTROLS:

12 VOLUME:

11 BALANCE

REAR PANEL CONNECTIONS

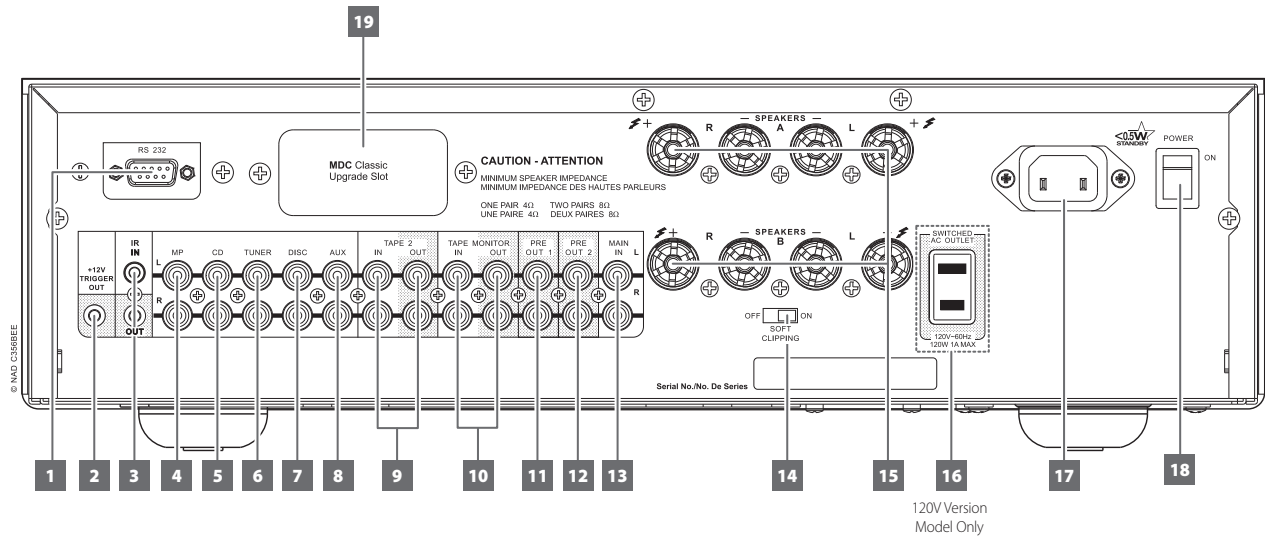

- | | |
|--------------------------|---|
| 1 RS-232 | 10 TAPE MONITOR IN/OUT |
| 2 12V TRIGGER OUT | 11 PRE OUT 1: |
| 3 IR IN/OUT | 12 PRE OUT 2: |
| 4 MP INPUT | 13 MAIN IN: |
| 5 CD INPUT | 14 SOFT CLIPPING |
| 6 TUNER INPUT | 15 SPEAKERS |
| 7 DISC INPUT | 16 SWITCHED AC OUTLET (120V version only): |
| 8 AUX INPUT | 17 AC MAINS INPUT |
| 9 TAPE 2 IN/OUT: | 18 POWER SWITCH |
| | 19 MDC CLASSIC UPGRADE SLOT |

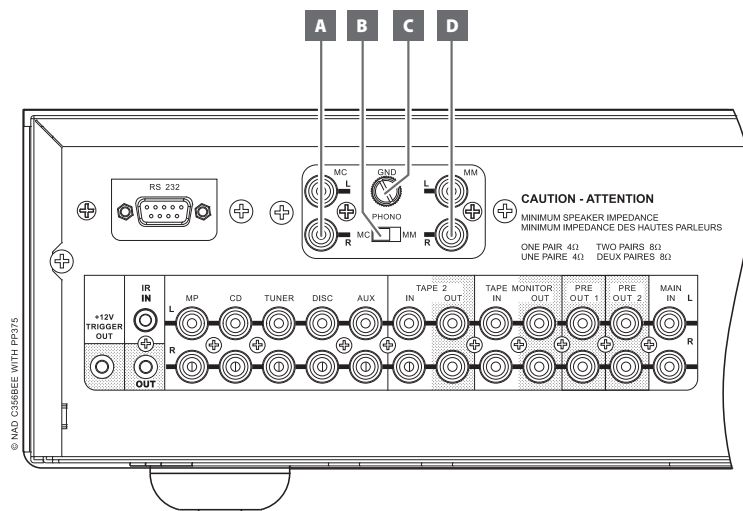

- | | |
|-----------------------|---------------------------------|
| A MC INPUT | C PHONO GROUND CONNECTOR |
| B MC-MM SWITCH | D MM INPUT |

SPECIFICATIONS

PREAMPLIFIER SECTION

LINE LEVEL INPUT, PRE OUT

THD ¹ 20 Hz – 20 kHz, CCIF IMD, SMPTE IMD, DIM 100	<0.005 % at 2 V out
Signal-to-Noise Ratio	>106 dB (IHF; A-weighted, ref. 500 mV out, unity gain) >114 dB (A-weighted, ref. 2 V out, Volume maximum) >92 dB (ref. 100 mV out, unity gain)
Channel separation -1 kHz	>80 dB
10 kHz	>68 dB
Input impedance (R and C)	22 kohms+ 100 pF
Maximum input signal	>6 Vrms (ref. 0.1 % THD)
Output impedance - Pre out	80 ohms
Tape out	Source Z + 1 kohm
Input sensitivity	166 mV (ref. 500 mV out)
Frequency response	±0.3 dB (20 Hz - 20 kHz, Tone defeat ON) ±0.3 dB (20 Hz - 20 kHz, Tone defeat OFF)
Maximum voltage output -IHF load	>10 V (ref. 0.03 % THD)
600 ohms load	>8 V (ref. 0.03 % THD)

TONE CONTROLS

Treble	±5 dB at 10 kHz
Bass	±8 dB at 100 Hz

POWER AMPLIFIER SECTION

MAIN IN, SPEAKER OUT

Continuous output power into 8 ohms and 4 ohms (Stereo)	>80 W (at rated THD, 20 Hz-20 kHz, both channels driven)
Rated THD ¹ 20 Hz – 20 kHz, CCIF IMD, SMPTE IMD, DIM 100	<0.007 %
Clipping power	>90 W (at 1 kHz 0.1 % THD)
IHF dynamic headroom - 8 ohms	+2.6 dB
4 ohms	+4.4 dB
IHF dynamic power - 8 ohms	145 W
4 ohms	220 W
2 ohms	290 W
Peak output current	>50 A (in 1 ohm, 1 ms)
Signal-to-noise ratio	>101 dB (A-weighted, ref. 1 W) >120 dB (A-weighted, ref. 80 W)
Damping factor	>100 (at 8 ohms, 50 Hz and 1 kHz)
Frequency response	±0.3 dB (ref. 20 Hz - 20 kHz) 3 Hz – 70 kHz (ref. -3 dB)
Input impedance	20 kohms + 1 nF
Input sensitivity	950 mV (for 80 W in 8 ohms)
Voltage gain	29 dB
Headphone output impedance	220 ohms
Channel separation - 1 kHz	>80 dB
10 kHz	>70 dB

TRIGGER OUT

Output resistance	75 ohms
Output current	150 mA
Output voltage	+12 V ± 10 %

SPECIFICATIONS

PHONO SECTION (WITH OPTIONAL PP 375 INSTALLED)

MM/MC IN, PRE OUT

Input impedance - MC	100 ohms (R) 180 pF (C)
MM	47 kohms (R) 180 pF (C)
Input sensitivity ² for 80 W in 8 ohms - MC	0.38 mV 1 kHz
MM	5.0 mV 1 kHz
Input sensitivity ² for 1 W in 8 ohms - MC	39 μ V 1 kHz
MM	0.56 mV 1 kHz
Input overload - MC	0.6 mV/5.9 mV/58 mV (20 Hz/1 kHz/20 kHz)
MM	9.3 mV/85 mV/850 mV (20 Hz/1 kHz/20 kHz)
Gain - MC in - TAPE OUT ³	57.0 dB (at 1 kHz, 10 kohms load)
MM in - TAPE OUT	34.2 dB (at 1 kHz, 10 kohms load)
THD1 (CCIF IMD, DIM 100)	<0.009 % (20 Hz – 20 kHz, 4 Vrms TAPE OUT)
Signal-to-Noise Ratio, IHF A-weighted - MC ⁴	>78 dB (ref. 0.5 mV input, 10 ohms source)
MM ⁵	>75 dB (ref. 5 mV input, IHF cartridge source)
RIAA response accuracy	\pm 0.5 dB (20 Hz – 50 Hz) \pm 0.3 dB (50 Hz – 20 kHz)
Infrasonic filter	-3 dB at 10 Hz -14 dB at 4 Hz
Channel Separation - MC	>60 dB (1 kHz and 10 kHz)
MM	>60 dB (1 kHz and 10 kHz)

OVERALL SPECIFICATIONS

LINE LEVEL INPUT, SPEAKER OUT

Continuous output power into 8 ohms and 4 ohms (Stereo)	>80 W (at rated THD, 20 Hz-20 kHz, both channels driven)
THD ¹ 20 Hz – 20 kHz, CCIF IMD, SMPTE IMD, DIM 100	<0.009 % (250 mW to 80 W, 8 ohms and 4 ohms)
Signal-to-Noise Ratio	>92 dB (IHF; A-weighted, 500 mV input, ref. 1 W out in 8 ohms) >110 dB (IHF; A-weighted, ref. 80 W in 8 ohms, maximum volume)
Frequency response	\pm 0.3 dB (20 Hz - 20 kHz, Tone Defeat ON) 10 Hz – 65 kHz (-3 dB)
Channel separation - 1 kHz	>80 dB
10 kHz	>68 dB

POWER CONSUMPTION

Rated power	350 W (at 230 V AC 50 Hz; 120V AC 60 Hz)
Standby power	<0.5 W
Idle power	<40 W

DIMENSION AND WEIGHT

Unit Dimensions (W x H x D) Gross ⁶	435 x 131 x 337 mm 17 1/8 x 5 3/16 x 13 5/16 inches
Net weight	8.7 kg (19.2 lbs)
Shipping weight	10.6 kg (23.4 lbs)

LEGEND:

- 1 THD is the sum of all the harmonic components within the 80 kHz measurement bandwidth and does not include noise.
- 2 Measured from Speaker Out.
- 3 Measured with 10 ohms generator impedance.
- 4 Measured with 10 ohms input termination.
- 5 Measured with MM cartridge connected (600 mH + 600 ohms).
- 6 Gross dimensions include feet, volume knob and tightened speaker terminals.

Specifications are subject to change without notice. For updated documentation and features, please log onto www.NADelectronics.com for the latest information about C 356BEE.

WIRING DIAGRAM

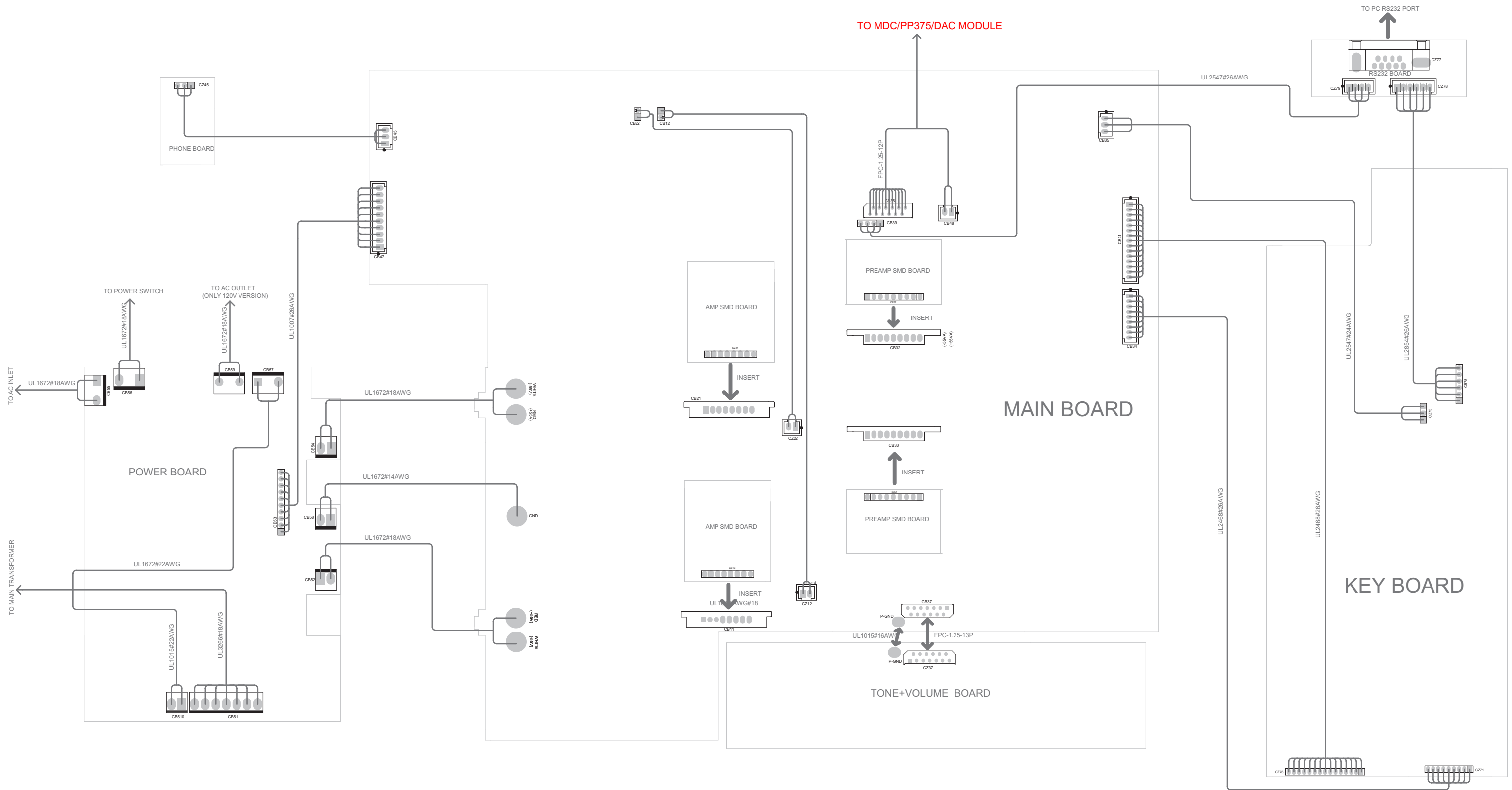

BLOCK DIAGRAM

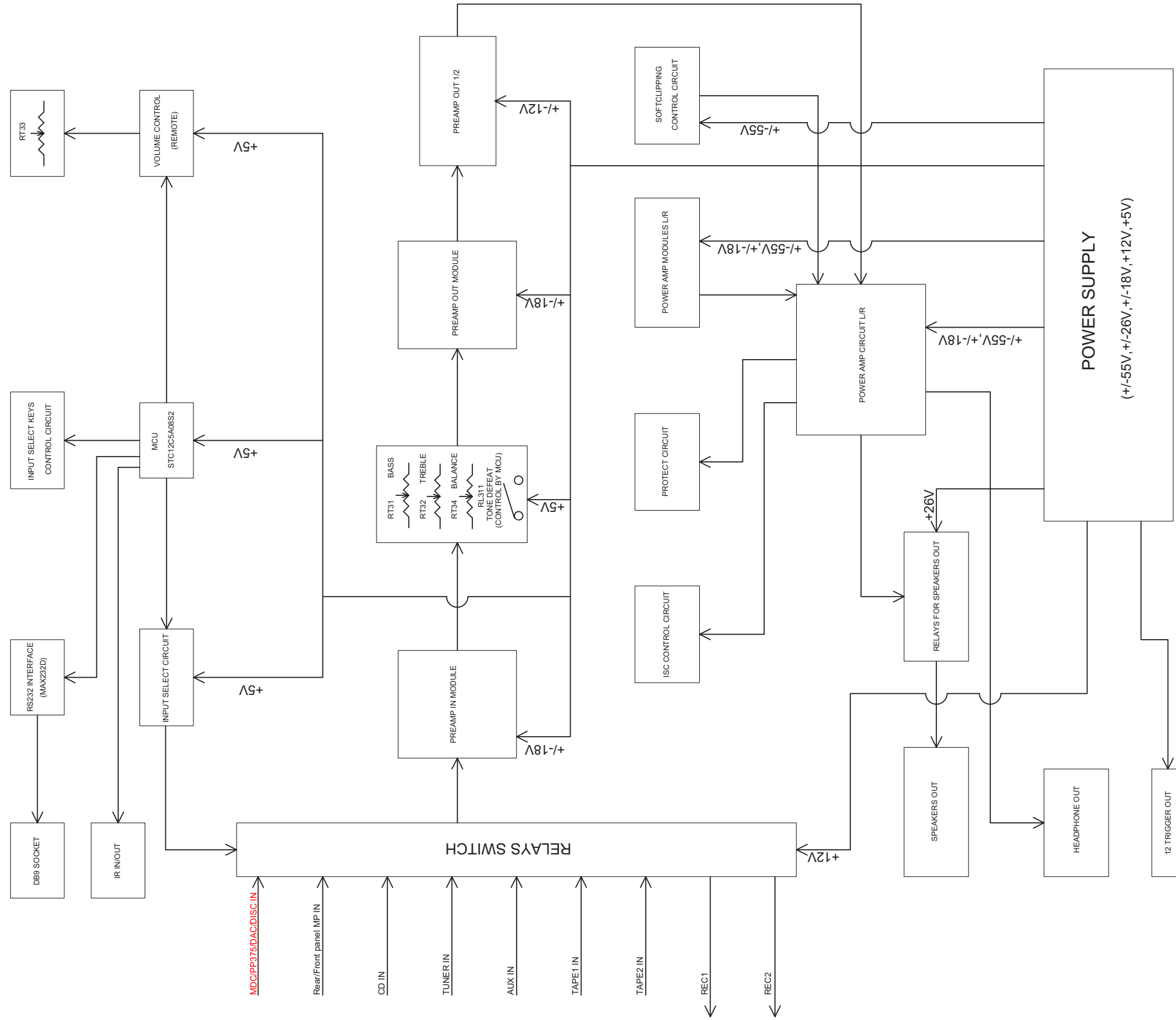

MICROPROCESSOR CONNECTION DIAGRAM

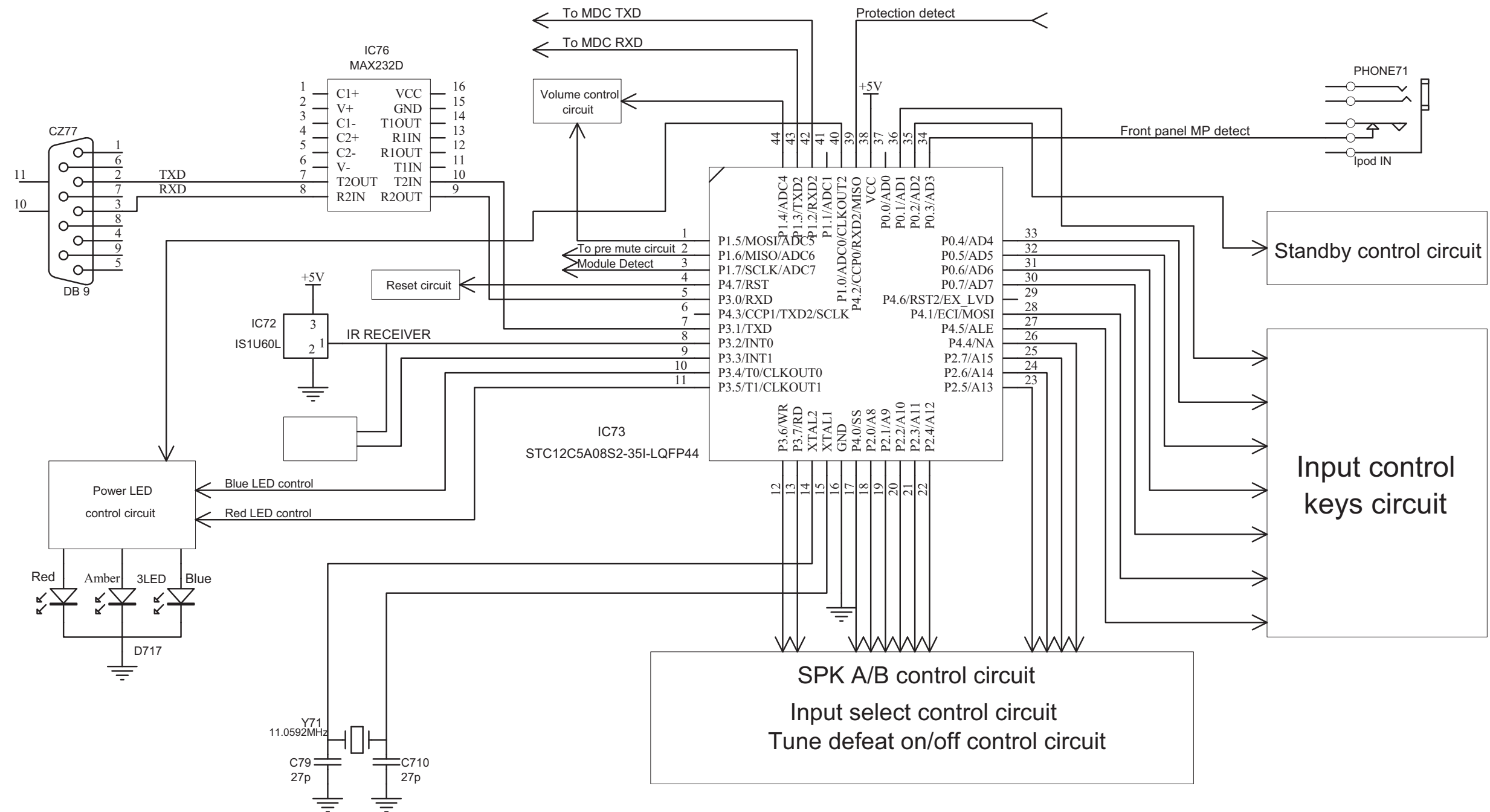

STC12C5A08S2

KEY BOARD IC73

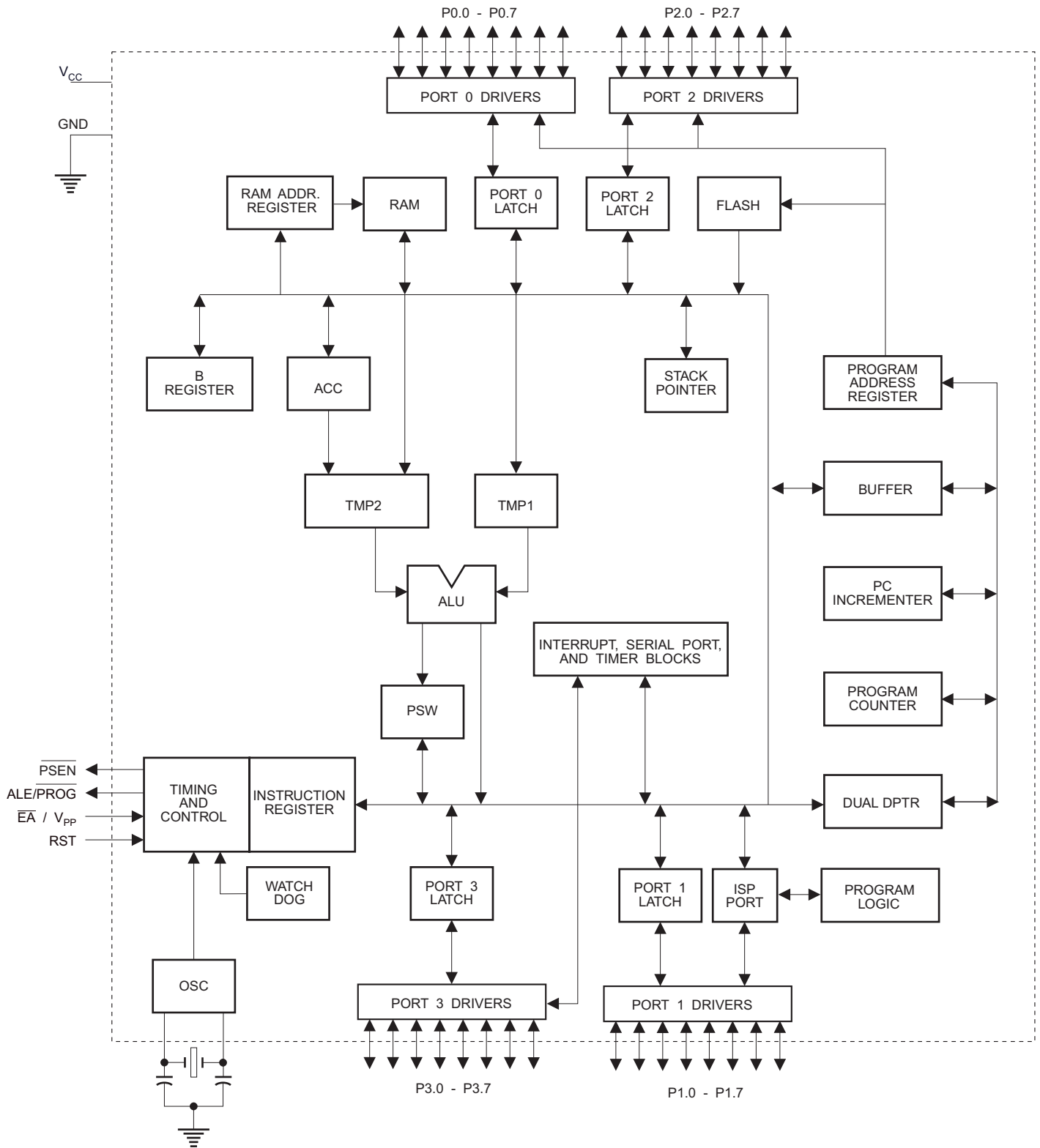

MAX232D
KEYBOARD: IC76

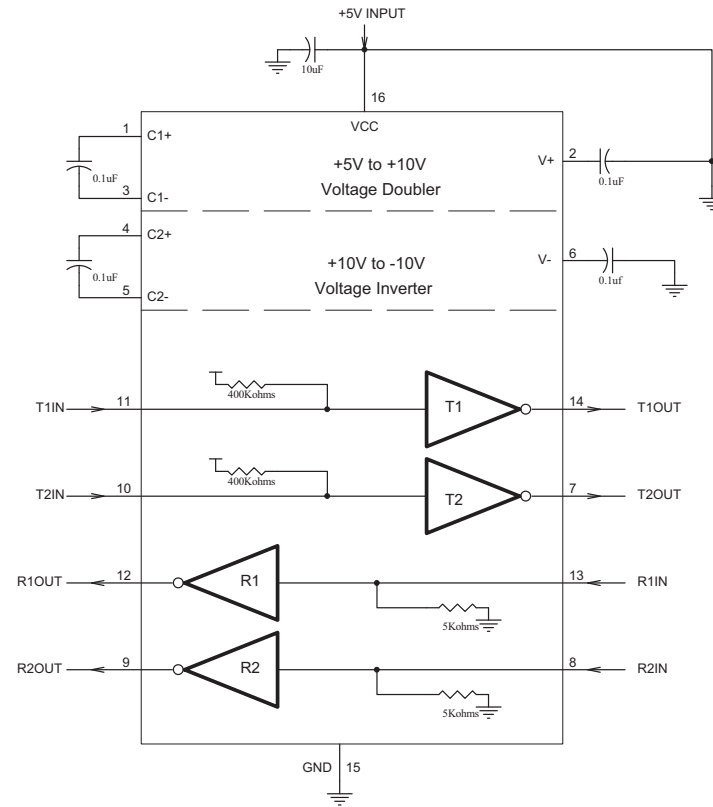
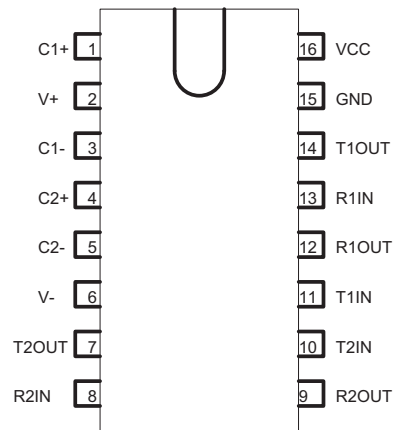

ALIGNMENT PROCEDURES

I. INITIAL

A. LOWEST VOLUME ADJUSTMENT

1. Tune the volume pot to lowest state.
2. Input a high voltage signal such as 5V from CD input.
3. Connect a oscilloscope to L channel binding posts.
4. Observing the oscilloscope,adjust VR301,make the output of speakers become to the lowest level.
5. Adjusting VR302,make R channel output become to the lowest level by same way.

B. IDLING CURRENT

1. Power on
2. Running 5 minutes with no signal
3. Connect a DC voltmeter to TP1 and TP2 ,adjust VR22/VR23 for 6mV reading on voltmeter.
4. Connect a DC voltmeter to TP3 and TP4 ,adjust VR12/VR13 for 6mV reading on voltmeter.

C.ISC CIRCUIT ORIGINAL ADJUSTING

Adjust the pot VR3 to make the DC voltage of the point of TP10 to the same as TP11

II. FINAL ADJUSTMENT

Repeat procedure A,B and C for the lowest volume level, idling current alignment and ISC original level respectively.

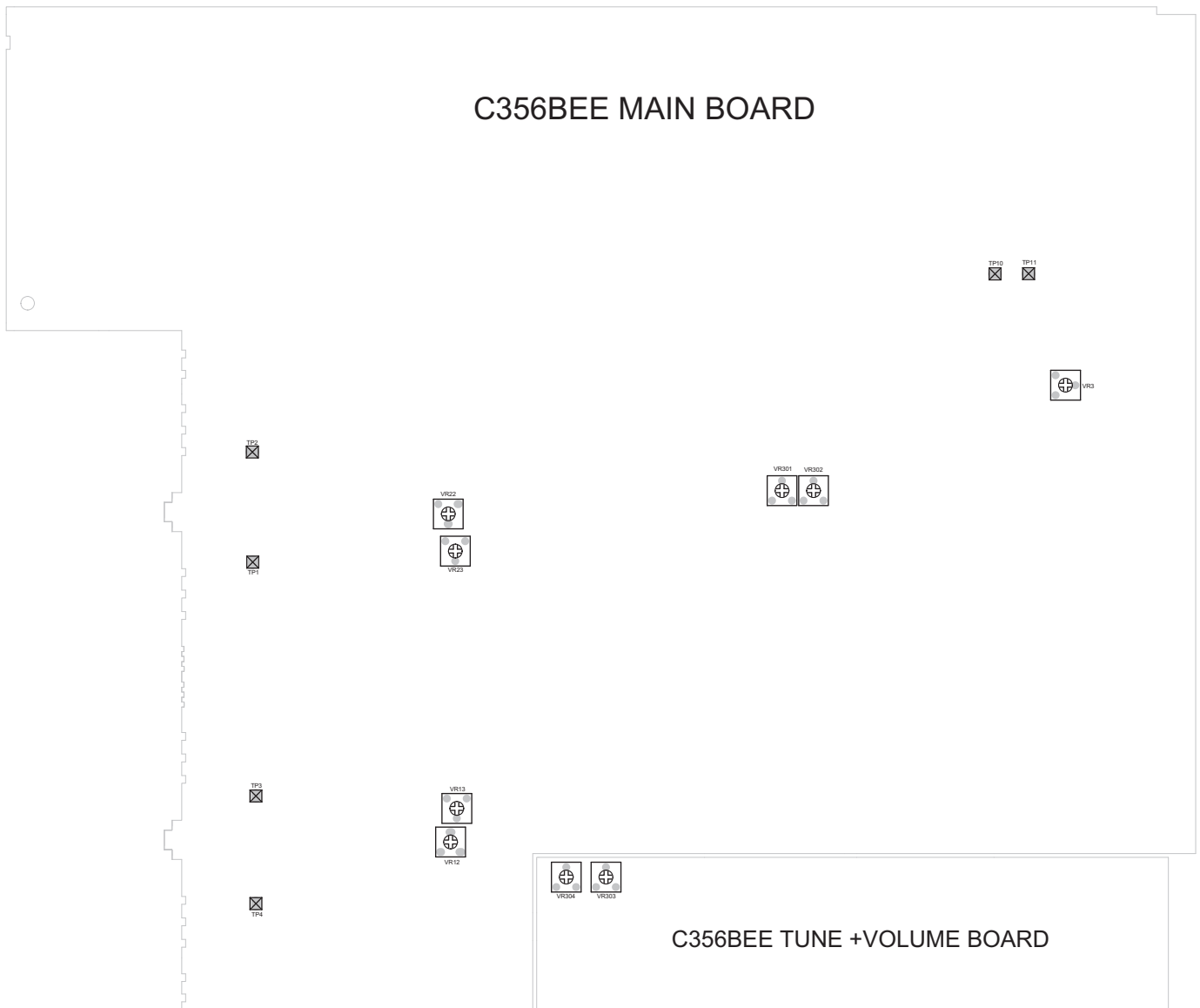

SCHEMATICS DIAGRAM(1/4)

POWER SUPPLY CIRCUIT Vm1.0
PCB-2:POWER BOARD Vm1.0

NAD C356BEE POWER CIR.

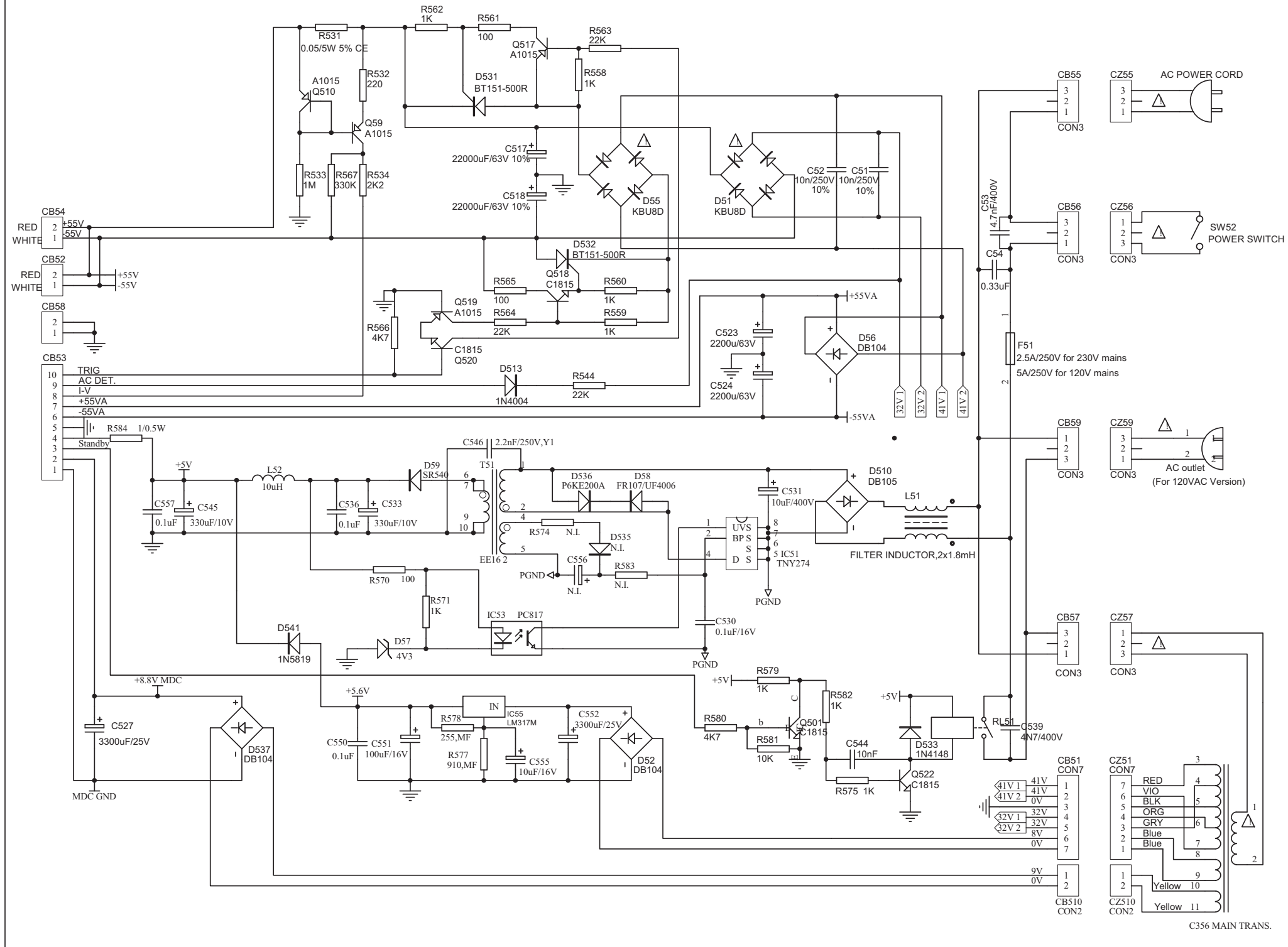

SCHEMATICS DIAGRAM(2/4)

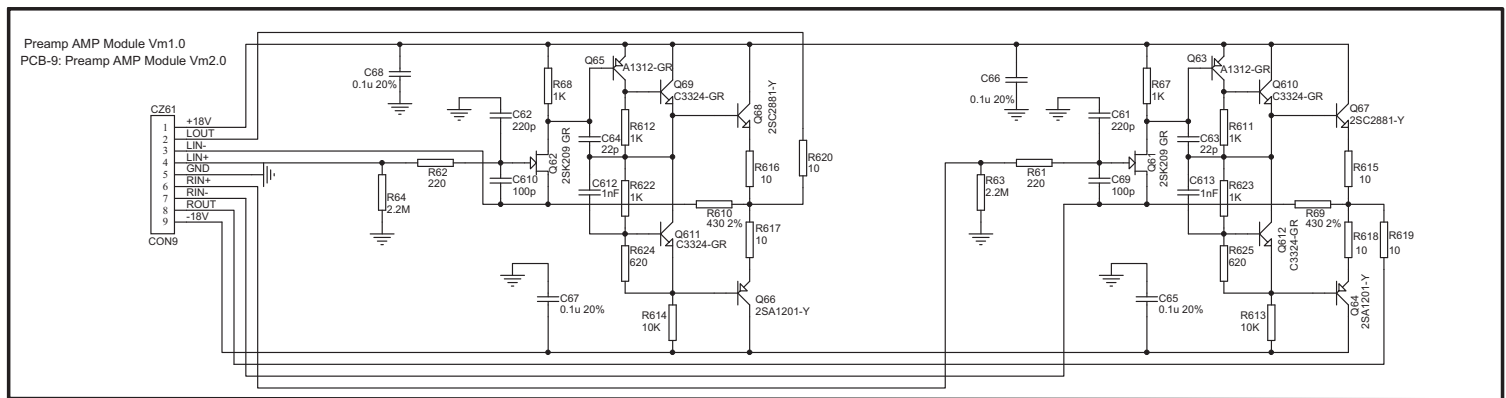
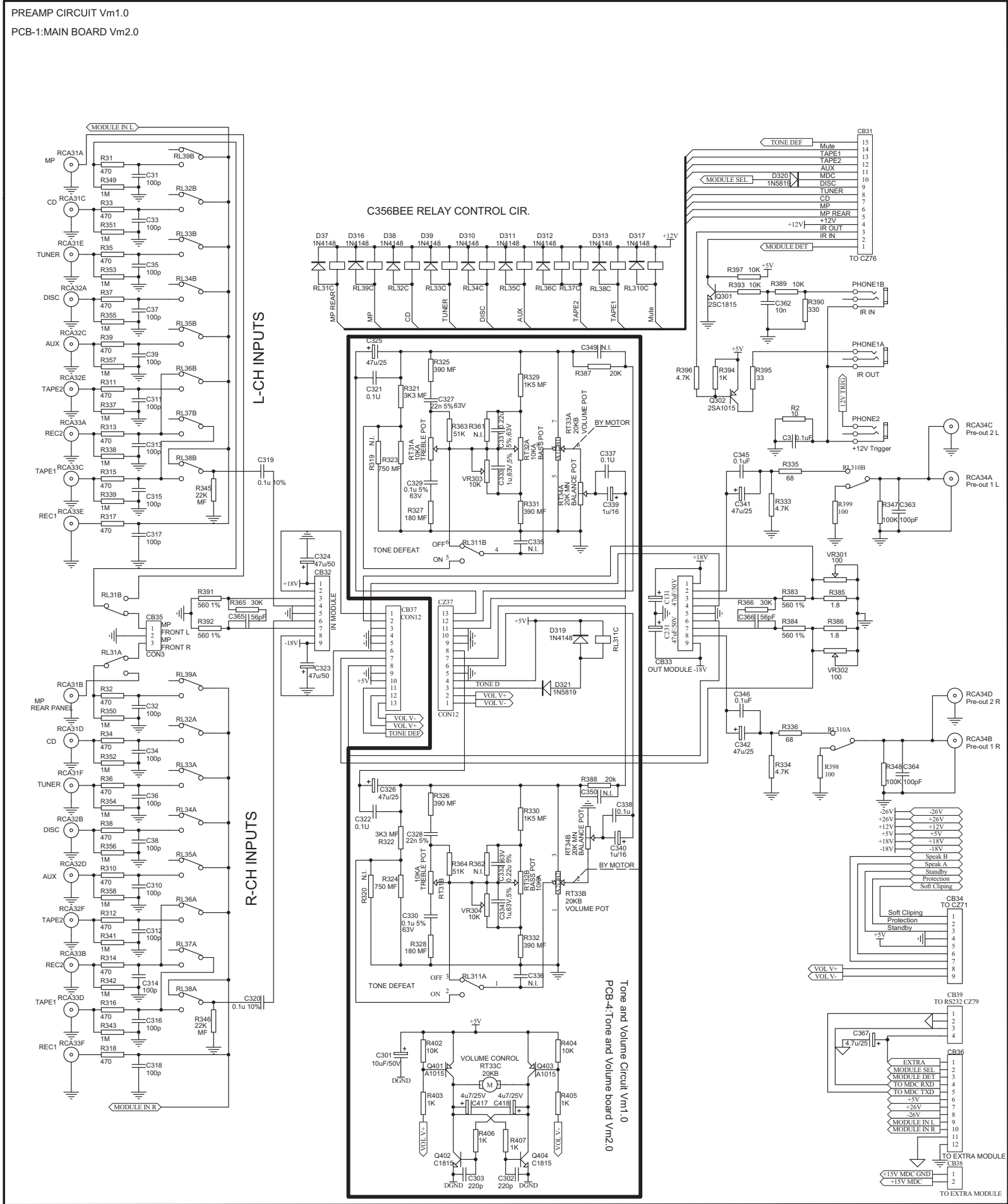

SCHEMATICS DIAGRAM(3/4)

AMP CIRCUIT Vm1.1
PCB-1-MAIN BOARD Vm2.0

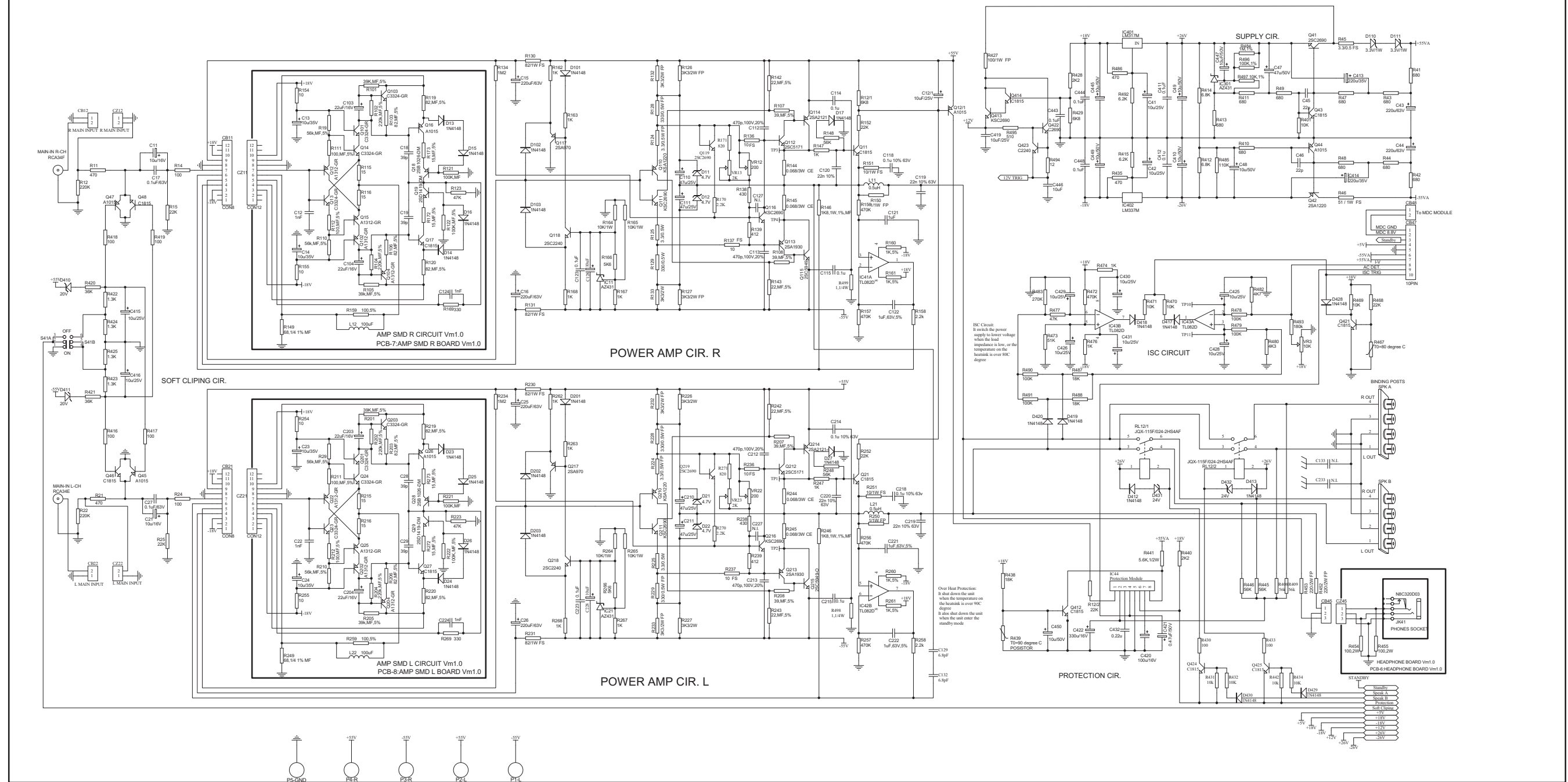

SCHEMATICS DIAGRAM(4/4)

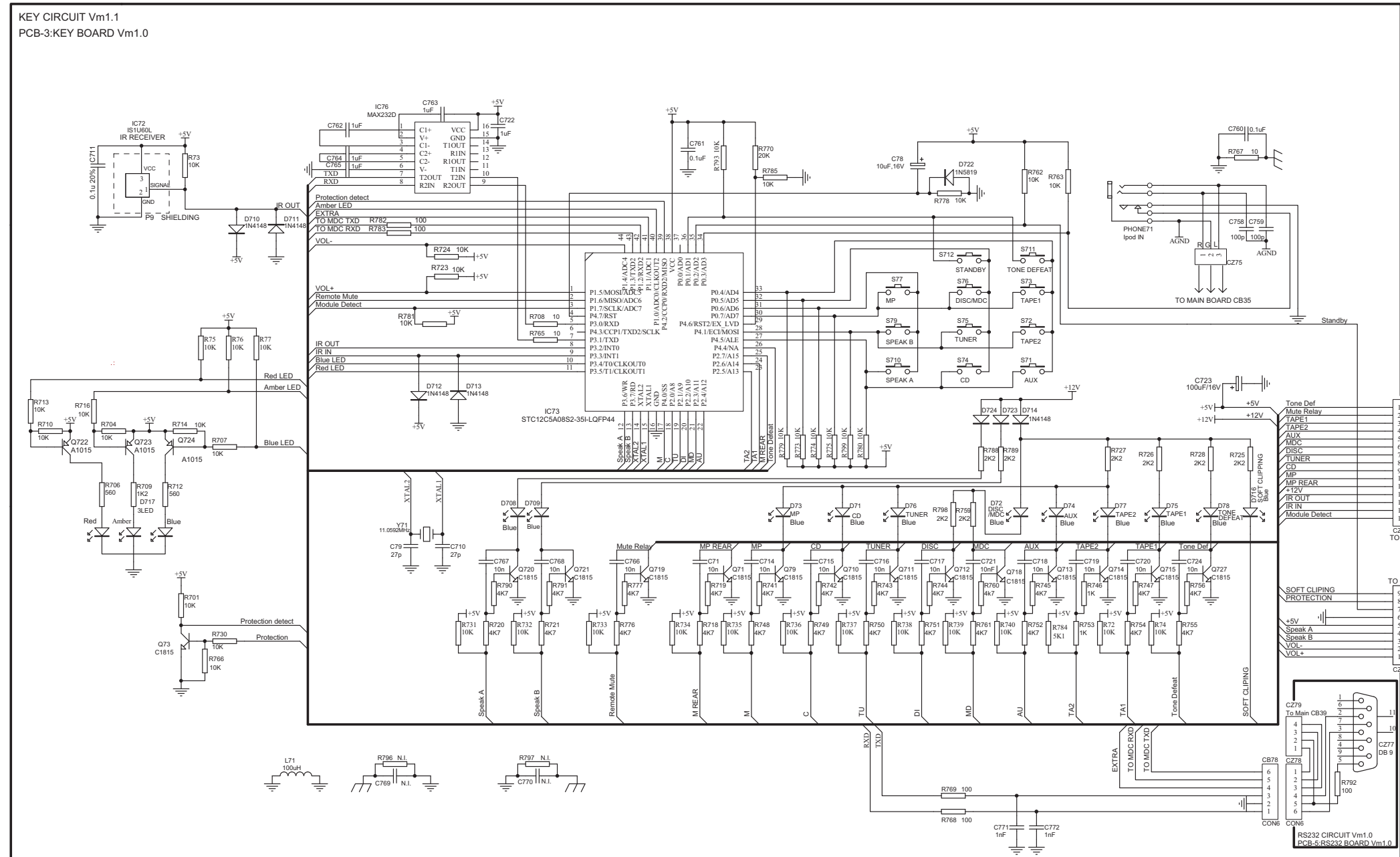

PCB-1:MAIN BOARD Vm3.0

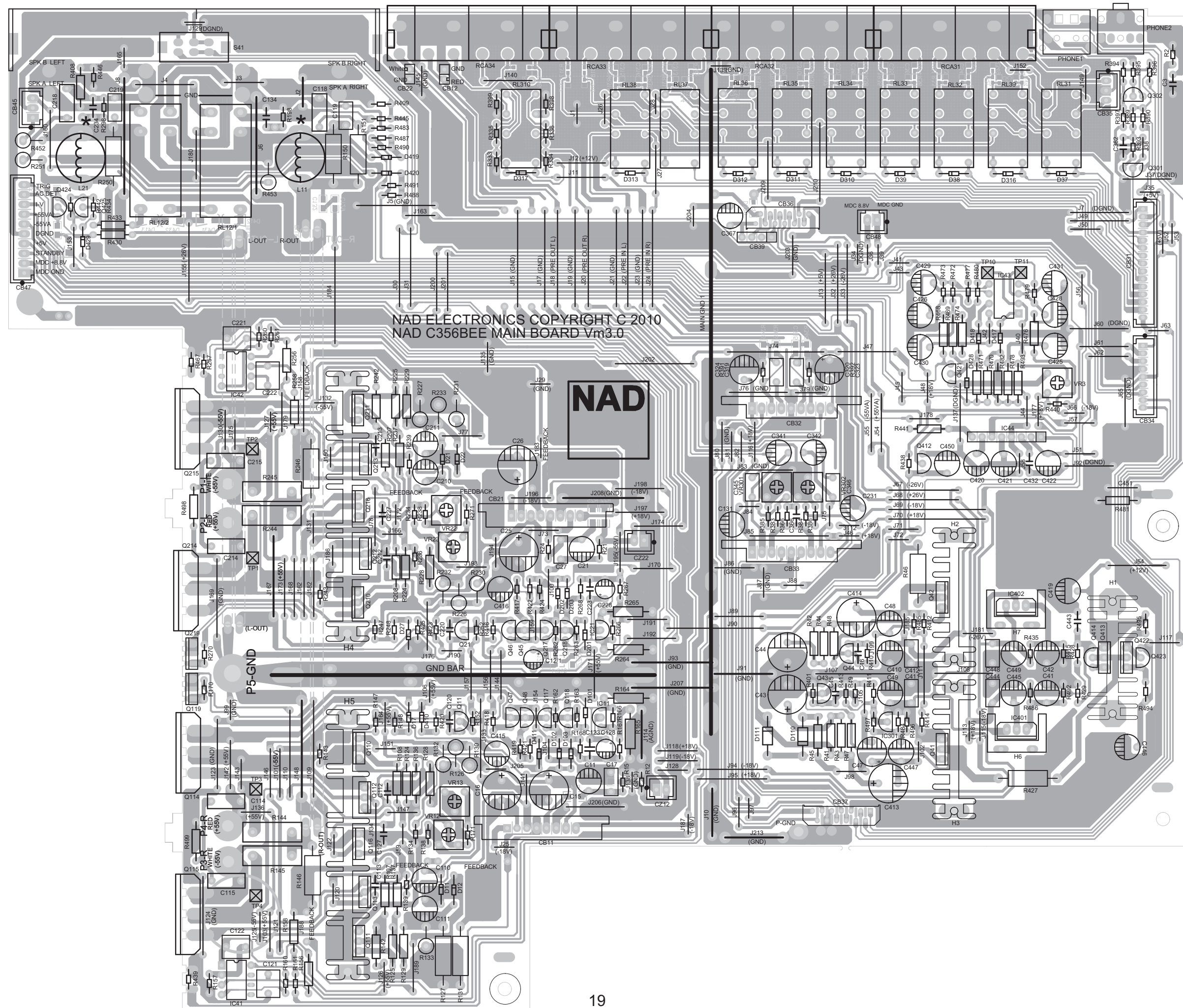

NAD ELECTRONICS COPYRIGHT C 2010
NAD C356BEE MAIN BOARD Vm3.0



PCB-2:POWER BOARD Vm2.0
TOP VIEW

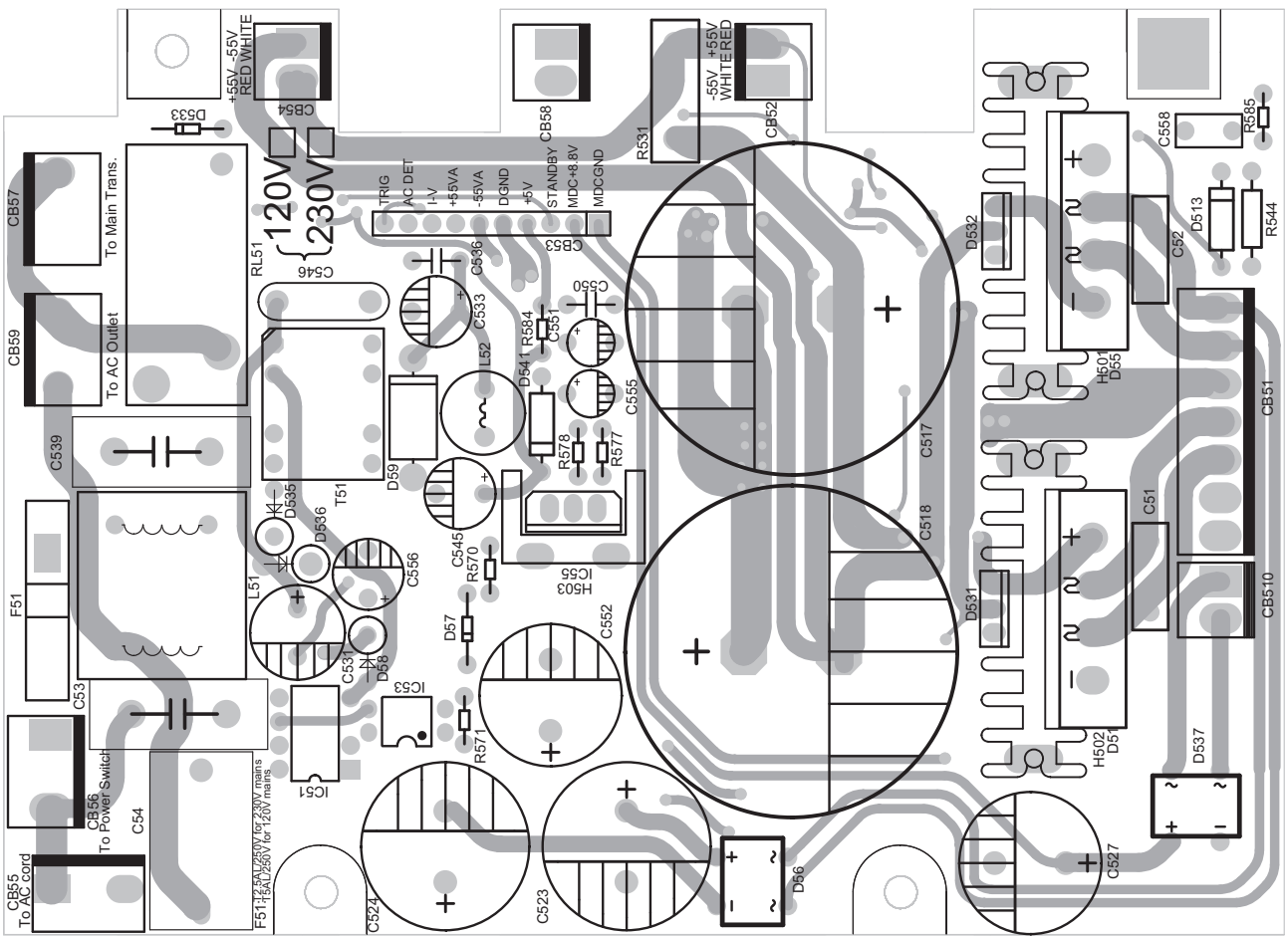

PCB-2:POWER BOARD Vm2.0
BOTTOM VIEW

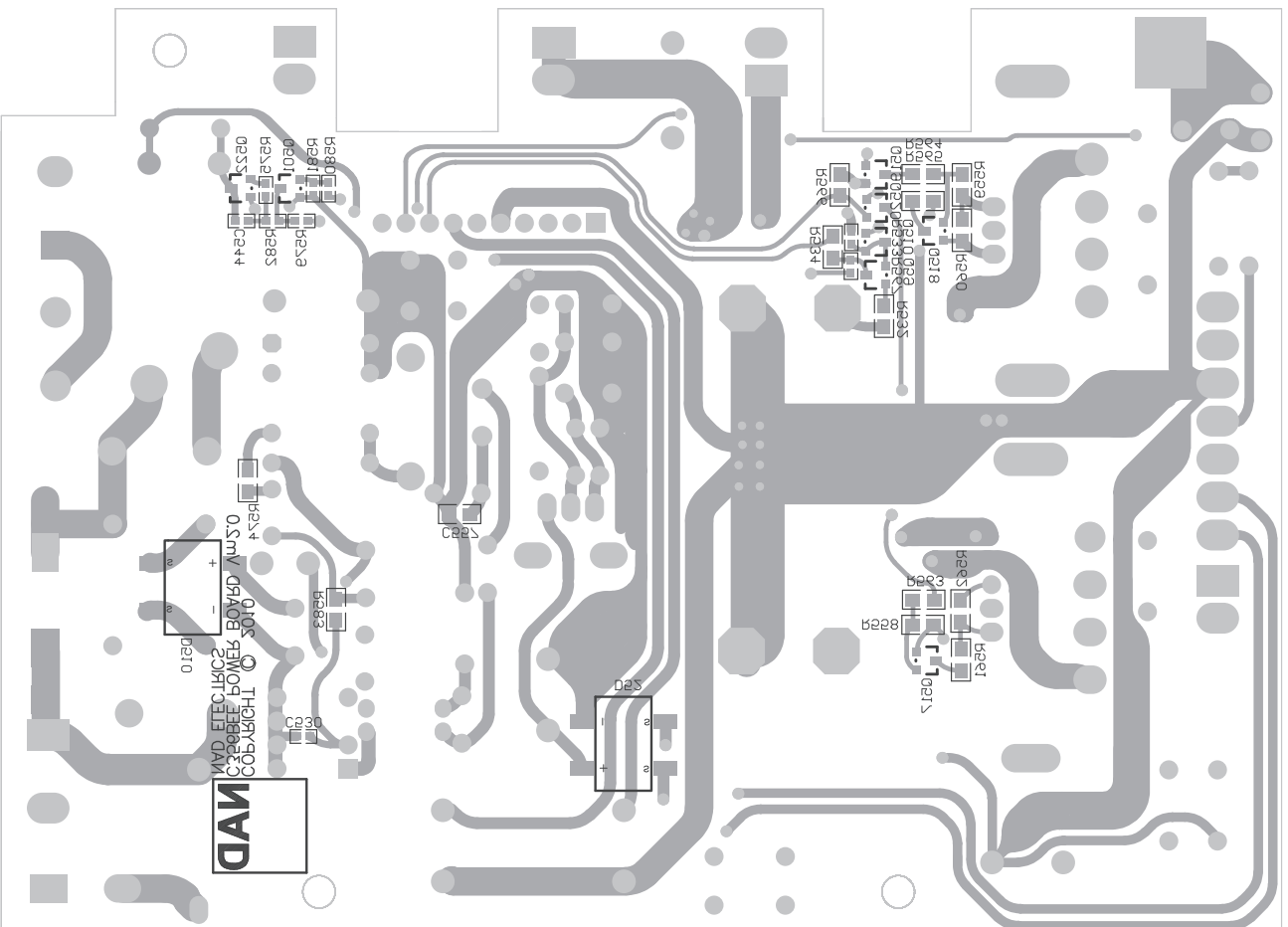

PCB-3:KEY BOARD Vm1.0
TOP VIEW

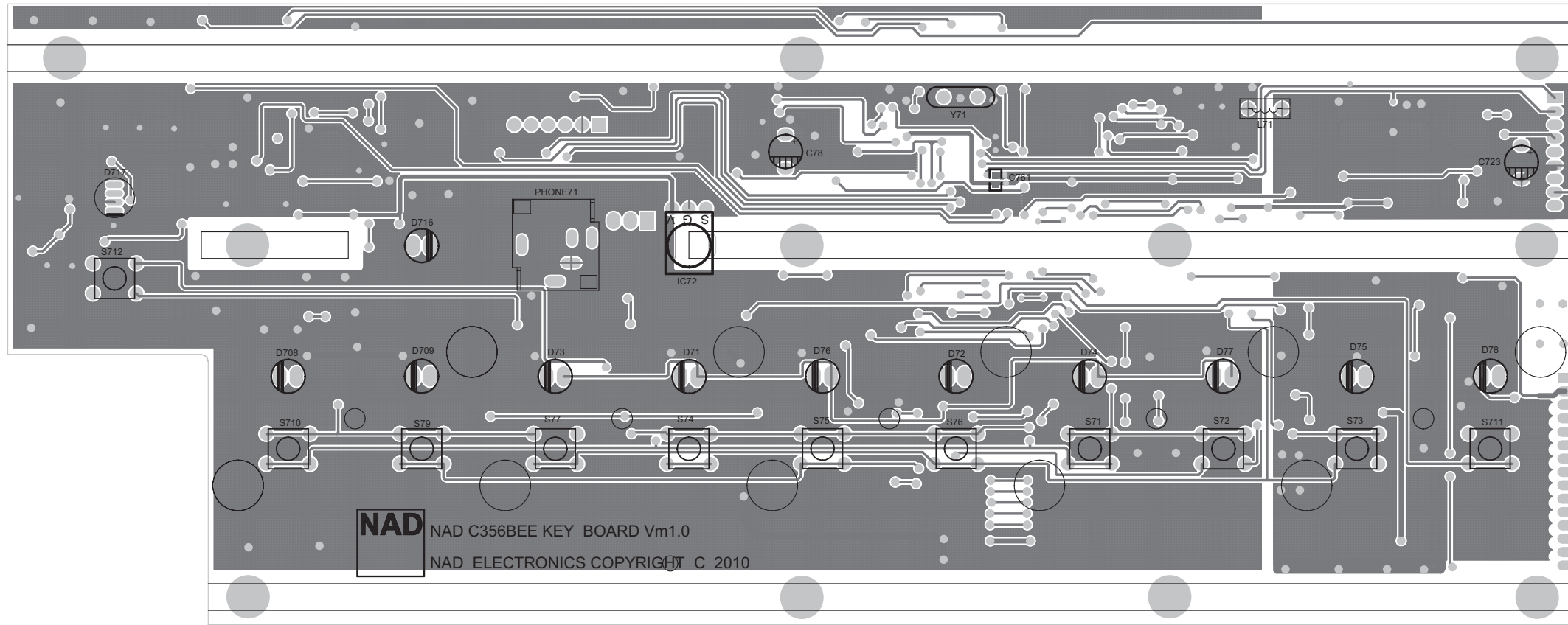

PCB-3:KEY BOARD Vm1.0
BOTTOM VIEW

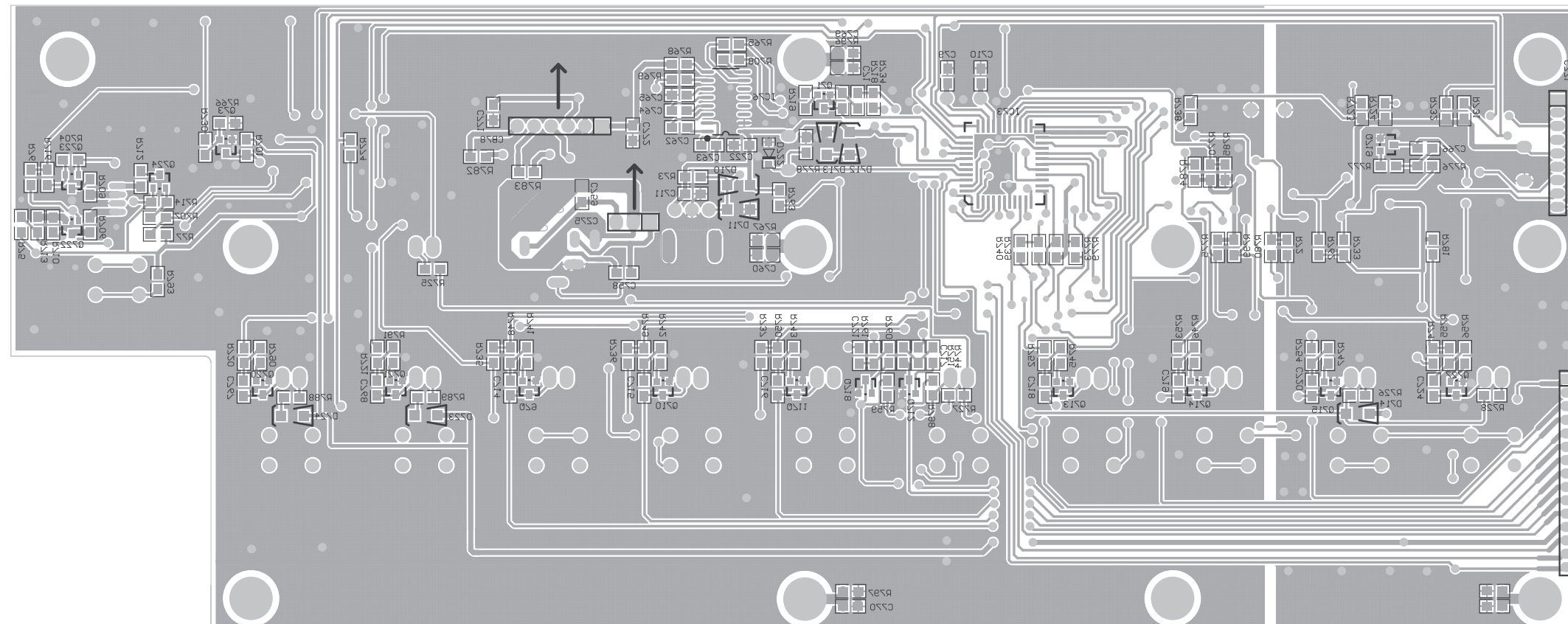

PCB-8:AMP SMD L BOARD Vm1.0
TOP VIEW

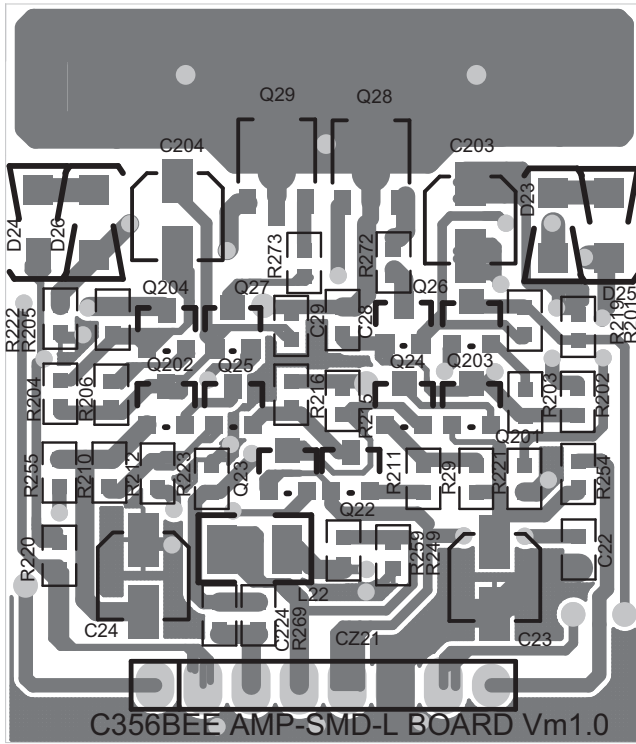

PCB-8:AMP SMD L BOARD Vm1.0
BOTTOM VIEW

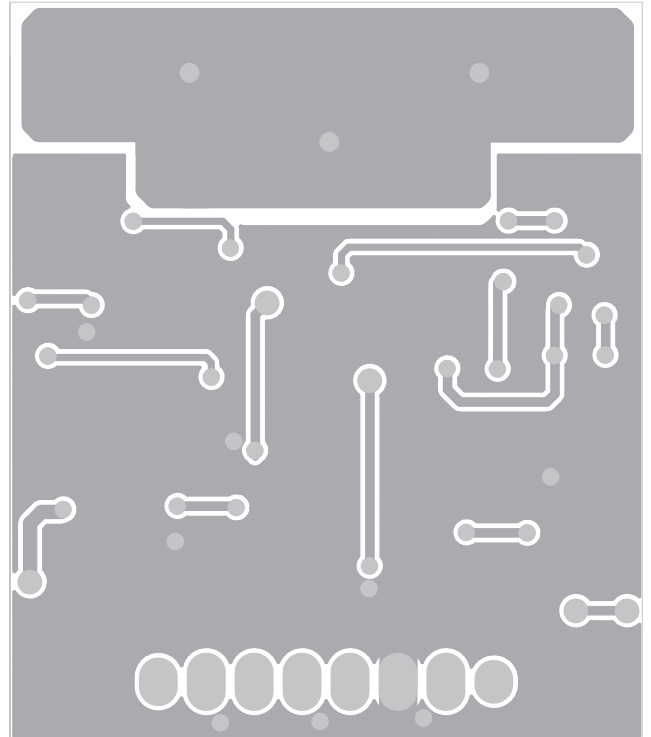

PCB-7:AMP SMD R BOARD Vm1.0
TOP VIEW

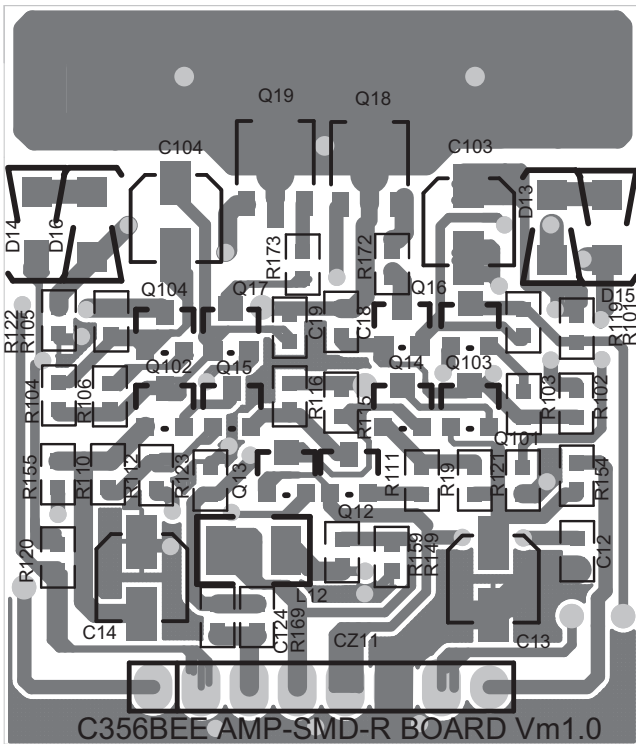

PCB-7:AMP SMD R BOARD Vm1.0
BOTTOM VIEW

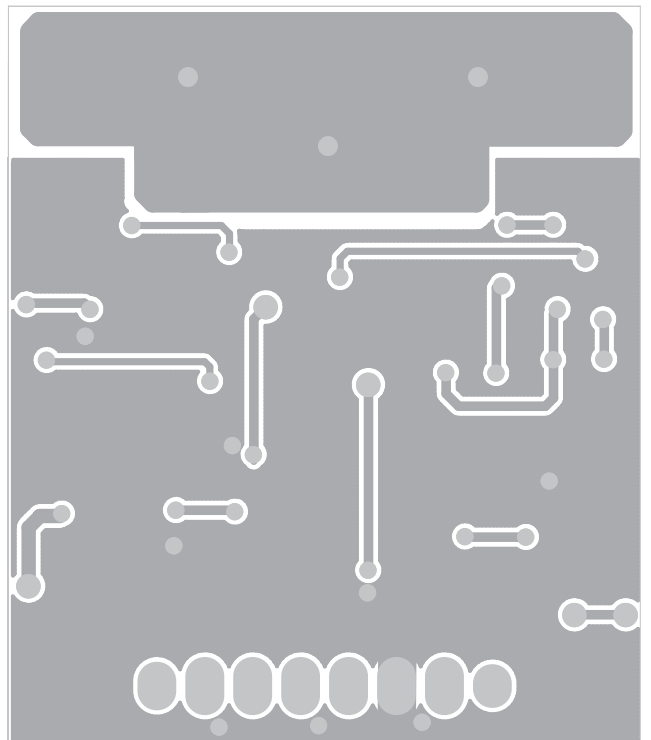

PCB-5:RS232 BOARD Vm2.0

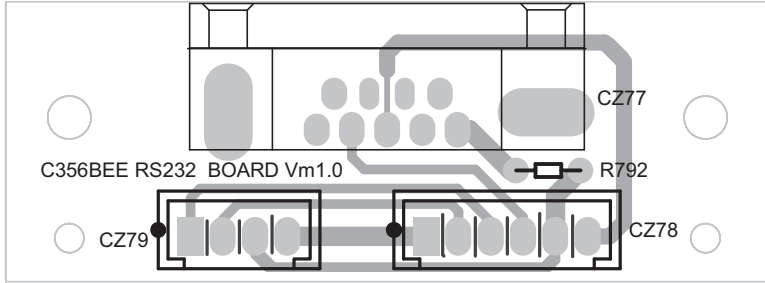

PCB-6:HEADPHONE BOARD Vm2.0

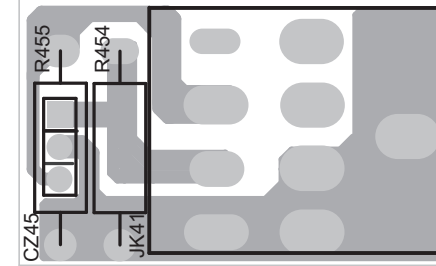

01-35604-00

PCB-4:TONE AND VOLUME BOARD Vm2.0

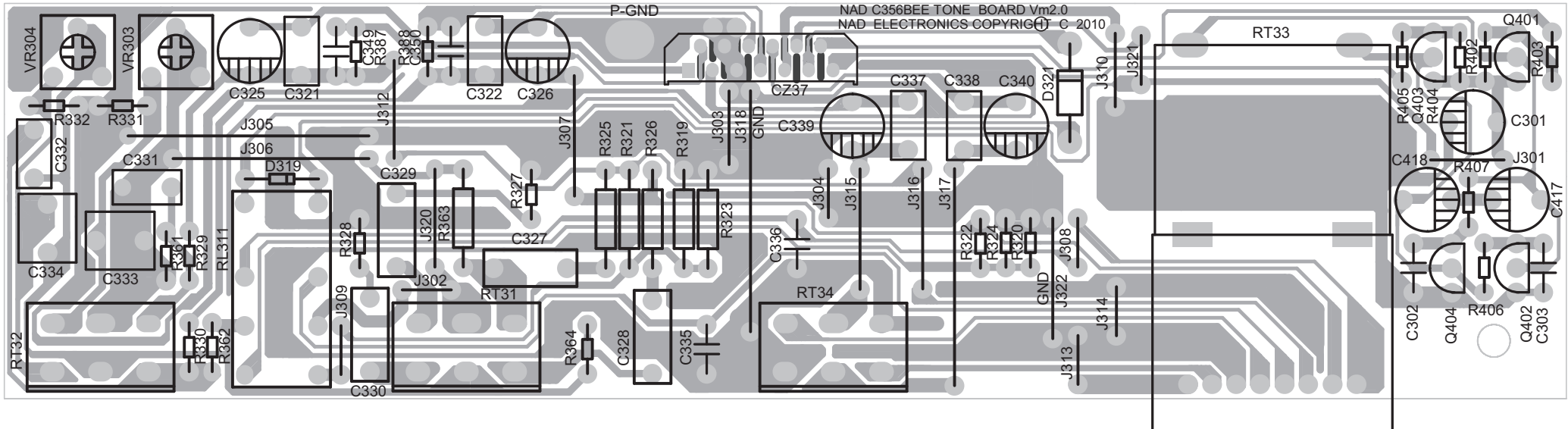

PCB-9:C355/C356/C725BEE PREAMP SMD BOARD Vm2.0
TOP VIEW

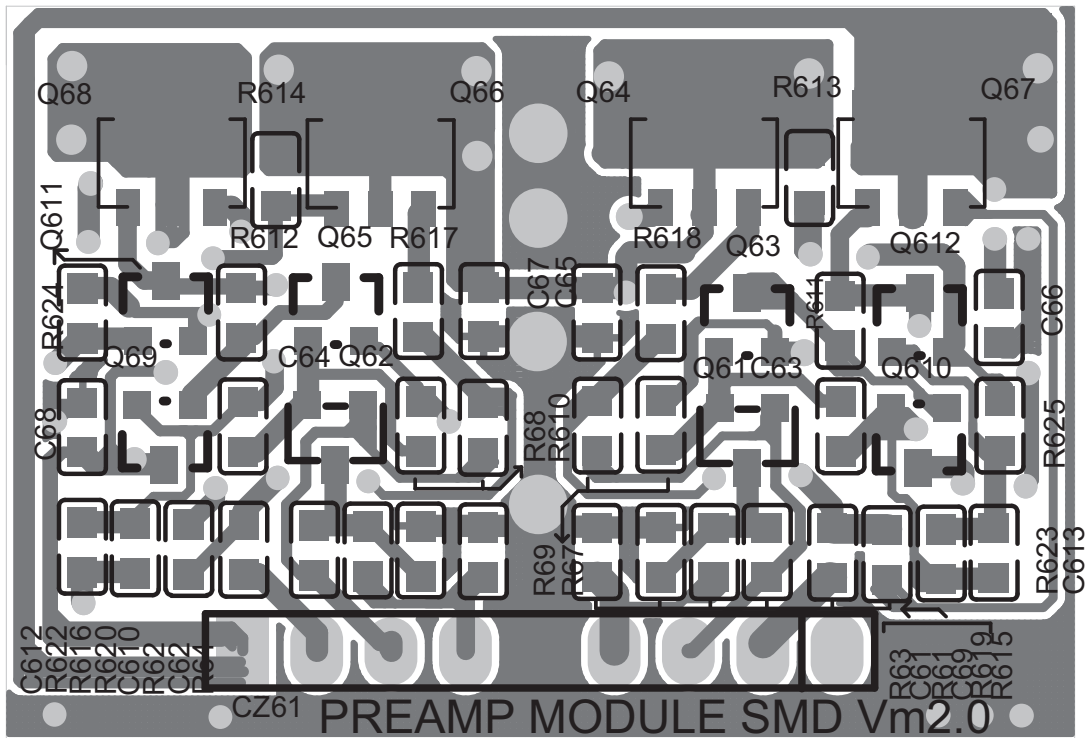

PCB-9:C355/C356/C725BEE PREAMP SMD BOARD Vm2.0
BOTTOM VIEW

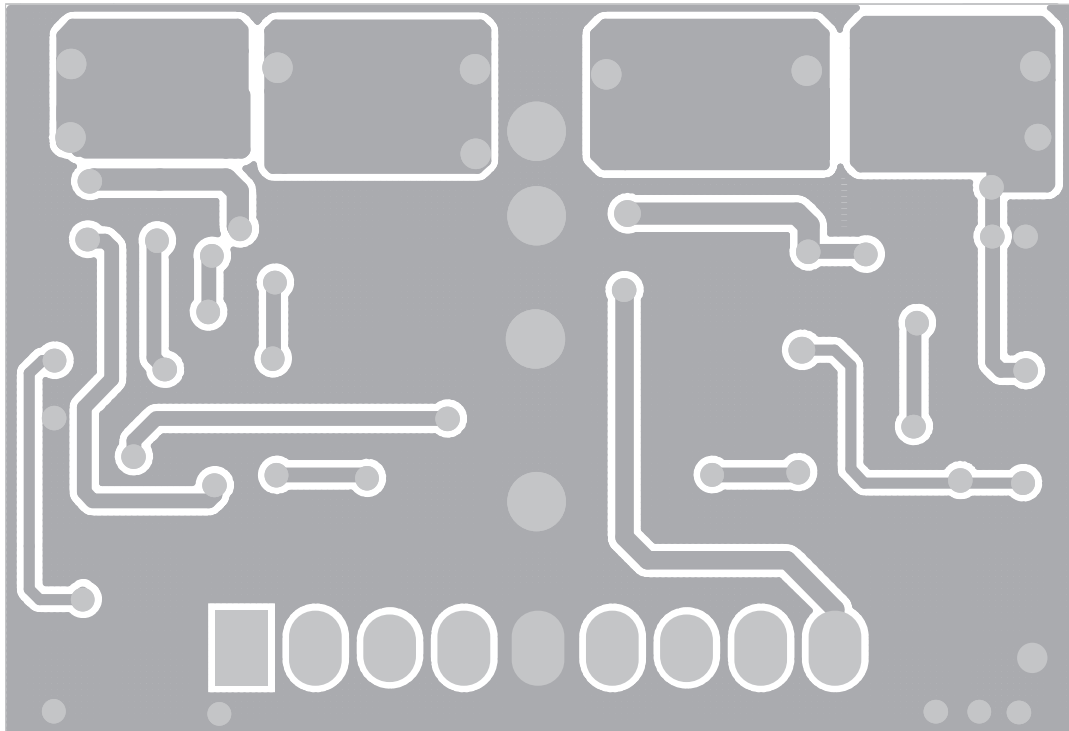

TROUBLESHOOTING GUIDE

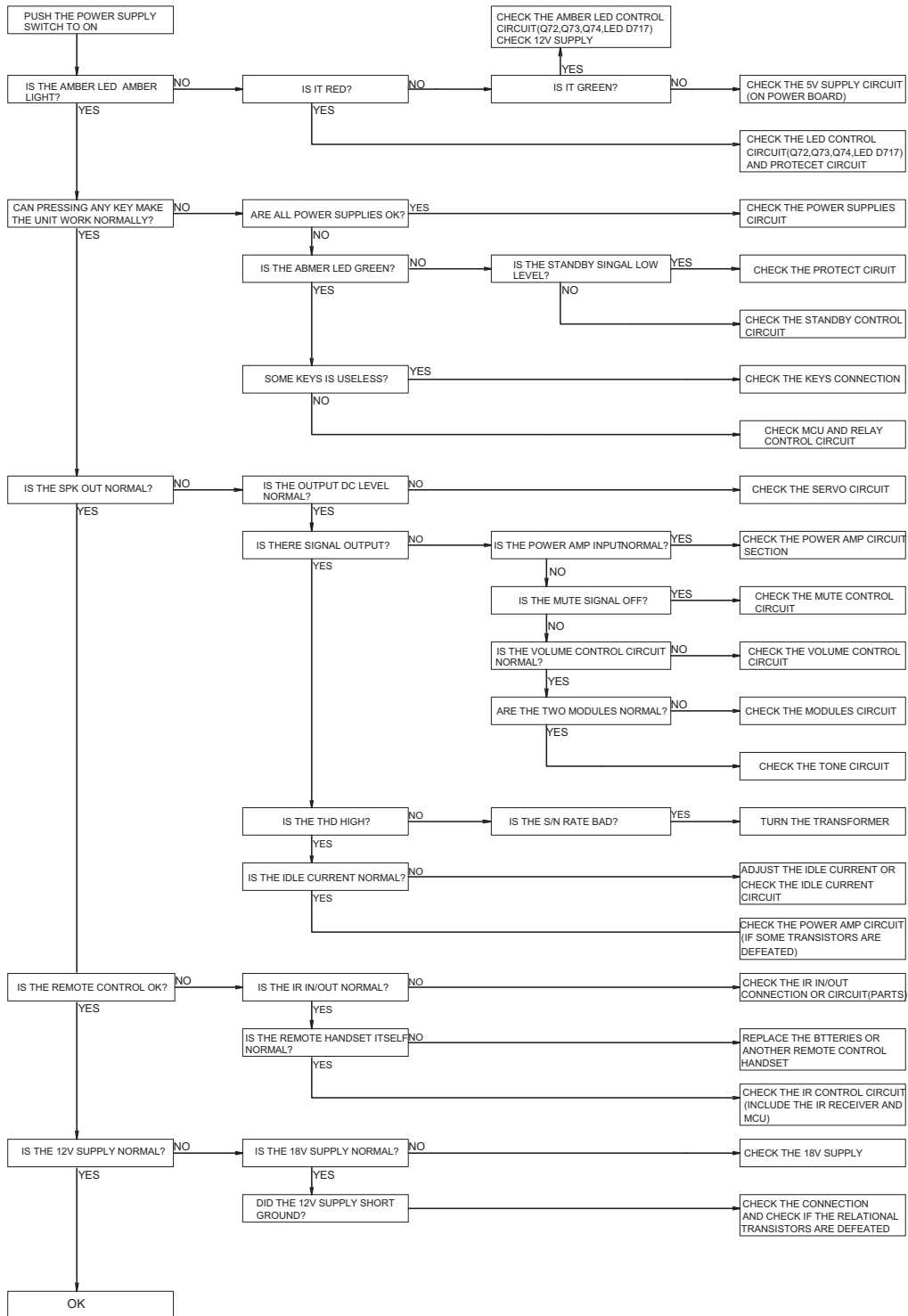

ELECTRIAL PARTS LIST		
PCB-1:MAIN BOARD 01-35601-00		
CIRCUIT NO.	PART NO.	DESCRIPTION
ICS		
IC401	03-00317-00	LM317M
IC402	03-00337-00	LM337M
IC11, IC21, IC301	03-00431-03	AZ431BZ-B
IC41,IC42,IC43	03-00082-00	TL082CP/CN/D
IC44	02-01237-10	Hansong Protection Module
DIODES		
D320	33-05819-01	1N5819HW-7-F, 40V, 1A
D412, D413, D430	33-44148-17	1N4148W-NR,SOD123
D431, D432	33-12400-11	24V, 1/2W , LL34
D17, D27, D37, D38, D39, D101, D102, D103, D201, D202, D203, D310, D311, D312, D313, D316, D317, D417, D418, D419, D420, D429	33-44148-00	1N4148
D428	33-44148-00	1N4148
D11, D12, D21, D22	33-14709-00	4.7V, 0.5W
D410, D411	33-12000-10	20V, 1W
D110, D111	33-13309-07	3.3V, 1W
Or D110 / D111	or 33-15609-12 / 21- 06101-00	5.6V, 2W, 2EZ5.6D5-AP zener / 10mm link
TRANSISTORS		
Q12/1	31-01015-03	2SA1015,SMD
Q44, Q45, Q47, Q302	31-01015-00	2SA1015 GR
Q11, Q21, Q43, Q46, Q48, Q301, Q412, Q414, Q421, Q424, Q425	31-01815-00	2SC1815
Q117, Q217	J31-00970-00	2SA970 GR
Q118, Q218, Q423	J31-02240-00	2SC2240
Q41, Q111, Q116, Q211, Q216,Q413, Q422	31-02690-00	KSC2690AYSTU
Q42, Q110, Q210	31-01220-00	KSA1220AYSTU
Q112, Q212	J31-05171-00	2SC5171
Q113, Q213	J31-01930-00	2SA1930
CAPACITORS		
C129,C132	26-68951-01	6.8pF, 50V,0805,NPO, C1608COG1H6R8D
C365	26-56051-01	56pJ,50V,0805,NPO
C31, C32, C33, C34, C35, C36, C37, C38, C39, C310, C311, C312, C313, C314, C315, C316, C317, C318, C363, C364	26-10151-00	100pF, 50V, 5%, NPO
C45, C46	05-22013-02	22pF, 1KV, ±5%
C366	05-56013-00	56pF, 1KV, ±5%, DCH560J22SL
C112, C113, C212, C213	05-47113-00	470pF, 1KV, ±10%
C362	24-10312-00	10nF, 100V, ±20%
C120, C220	24-22312-04	22nF, 100V, ±10%
C3, C123, C223, C443	24-10412-01	0.1uF, 100V, ±20%
C432	24-22412-00	0.22uF, 100V, ±20%
C119, C219	25-22361-05	22nF, 63V, ±5%
C17, C27, C319, C320, C345, C346, C411, C412, C444, C448	25-10461-07	0.1uF, 63V, ±5%
C114, C115, C118, C214, C215, C218	25-10461-01	0.1uF, 63V, ±10%
C121, C122, C221, C222	25-10561-02	1u, 63V ±5%
C421	06-47851-02	0.47uF, 50V, ±20%
C367	06-47921-00	CD110,4.7uF,25V,± 20%,F5.0
C11, C21	06-10051-08	CD11A,10uF, 50V, ±20%, 85℃
C41, C42, C48, C49, C128, C228, C410, C415, C416, C419, C425, C426, C428, C429, C430, C431, C445, C446, C447, C449, C450, C12/1	06-10051-01	CD263(X),10uF,50V,± 20%,105℃,F5.0
C341, C342	06-47021-06	CD11A,47uF,25V,± 20%,F5.0

C47, C110, C111, C131, C210, C211, C231, C323, C324	06-47051-02	CD263(X),47uF,50V,± 20%,105°C,F5.0
C420	06-10121-02	CD263(X),100uF,25V,± 20%,105°C,F5.0
C15, C16, C25, C26, C43, C44, C413, C414	06-22161-01	CD263,220uF,63V,± 20%,105°C,F5.0
C422	06-33111-02	CD263(X),330uF,16V,± 20%,105°C,F5.0
RESISTORS		
R31, R32, R33, R34, R35, R36, R37, R38, R39, R310, R311, R312, R313, R314, R315, R316, R317, R318	07-90471-00	470Ω, ±5%
R347, R348	07-90104-00	100KΩ, ±5%
R337, R338, R339, R341, R342, R343, R349, R350, R351, R352, R353, R354, R355, R356, R357, R358	07-90105-00	1MΩ, ±5%
R11	07-90471-01	470Ω, ±5%
R12/1	07-90682-01	6K8Ω, ±5%
R12/2	07-90223-01	22KΩ, 0805, ±5%
R365	07-90303-01	30KΩ, ±5%
R345, R346	07-90223-01	22KΩ, ±5%
R431, R432	07-90103-01	10KΩ, 1/8W, ±5%
R14	07-90101-02	100Ω, ±5%
R25	07-90223-02	22KΩ, 1206, ±5%
R22	07-90224-02	220KΩ, ±5%
R385, R386	07-10189-50	1R8, 1/6W, ±5%
R2	07-10100-50	10Ω, 1/6W, ±5%
R494	07-10120-50	12Ω, 1/6W, ±5%
R395	07-10330-50	33Ω, 1/6W, ±5%
R335, R336	07-10680-50	68Ω, 1/6W, ±5%
R24, R398, R399, R416, R417, R418, R419	07-10101-50	100Ω, 1/6W, ±5%
R430, R433	07-10101-51	100Ω, 1/4W, ±5%
R390	07-10331-50	330Ω, 1/6W, ±5%
R138, R238	07-10431-50	430Ω, 1/6W, ±5%
R21	07-10471-50	470Ω, 1/6W, ±5%
R495	07-10511-50	510Ω, 1/6W, ±5%
R171, R271	07-10821-50	820Ω, 1/6W, ±5%
R147, R160, R161, R162, R163, R167, R168, R247, R260, R261, R262, R263, R267, R268, R394	07-10102-50	1KΩ, 1/6W, ±5%
R474, R476	07-10102-51	1KΩ, 1/4W, ±5%
R422, R423, R424, R425	07-10132-50	1K3Ω, 1/6W, ±5%
R158, R258	07-10222-51	2K2Ω, 1/4W, ±5%
R170, R270, R428, R440	07-10222-50	2K2Ω, 1/6W, ±5%
R480	07-10432-50	4K3Ω, 1/6W, ±5%
R333, R334, R396	07-10472-50	4K7Ω, 1/6W, ±5%
R482	07-10472-51	4K7Ω, 1/4W, ±5%
R429	07-10682-50	6K8Ω, 1/6W, ±5%
R166, R266	07-10562-50	5K6Ω, 1/6W, ±5%
R389, R393, R397, R401, R434, R442	07-10103-50	10KΩ, 1/6W, ±5%
R469, R470, R471	07-10103-51	10KΩ, 1/4W, ±5%
R438, R487, R488	07-10183-50	18KΩ, 1/6W, ±5%
R15, R152, R252	07-10223-50	22KΩ, 1/6W, ±5%
R468	07-10223-51	22KΩ, 1/4W, ±5%
R366	07-10303-50	30KΩ, 1/6W, ±5%
R420, R421	07-10363-50	36KΩ, 1/6W, ±5%
R477	07-10473-50	47KΩ, 1/6W, ±5%
R473	07-10513-50	51KΩ, 1/6W, ±5%
R148, R248, R409, R445, R446	07-10563-50	56KΩ, 1/6W, ±5%
R408	07-10563-51	56KΩ, 1/4W, ±5%
R479, R490, R491	07-10104-50	100KΩ, 1/6W, ±5%
R478	07-10104-51	100KΩ, 1/4W, ±5%
R485	07-10114-50	RT13, 110KΩ, 1/6W, ±5%
R493	07-10184-51	180KΩ, 1/4W, ±5%
R12	07-10224-50	220KΩ, 1/6W, ±5%
R483	07-10274-50	270KΩ, 1/6W, ±5%
R156, R256	07-10474-51	470KΩ, 1/4W, ±5%
R157, R257, R472	07-10474-50	470KΩ, 1/6W, ±5%
R134, R234	07-10125-50	1M2Ω, 1/6W, ±5%
R142, R242	07-20220-51	22Ω, 1/4W, ±5%
R143, R243	07-20220-50	22Ω, 1/6W, ±5%
R107, R108, R207, R208	07-20390-51	39Ω, 1/4W, ±5%
R139, R239	07-24120-50	412Ω, 1/6W, ±1%
R435, R486	07-24700-50	470Ω, 1/6W, ±1%
R383, R384, R391, R392	07-25600-50	560Ω, 1/6W, ±1%
R49, R410, R411, R413	07-26800-50	680Ω, 1/6W, ±1%

R41, R42, R43, R44, R47, R48	07-26800-51	RJ14, 680Ω, 1/4W, ±1%
R415, R492	07-26201-50	RJ13, 6.2KΩ, 1/6W, ±1%
R412, R414	07-26801-50	6K8Ω, 1/6W, ±1%
R497	07-21002-50	10KΩ, 1/6W, ±1%
R496	07-21003-50	100KΩ, 1/6W, ±1%
R484	07-21004-50	1MΩ, 1/6W, ±1%
R498, R499	07-20109-51	1Ω, 1/4W, ±5%
R441	07-20562-20	RJ15, 5.6KΩ, 1/2W, ±5%
R150, R250	07-30109-01	RY21, 1Ω, 1W, ±5%
R124, R125, R224, R225	07-30339-00	RY21, 3R3Ω, 1/2W, ±5%
R427	07-30101-03	RY21, 100Ω, 1W ±5%
R452, R453	07-30221-02	RY21, 220Ω, 2W, ±5%
R128, R129, R228, R229	07-30331-00	RY21, 330Ω, 1/2W, ±5%
R146, R246	07-30182-02	RY21, 1.8KΩ, 2W, ±5%
R126, R132, R133 R226, R227, R232, R233	07-30332-02	RY21, 3.3KΩ, 2W, ±5%
R127	07-30332-12	RY21, 3.3KΩ, 2W, ±5%
R164, R165, R264, R265	07-30103-11	RY21, 10KΩ, 1W, ±5%
R45	07-50339-11	RF10, 3.3Ω, 1/2W, ±5%
R46	07-50510-01	RF10, 51Ω, 1W, ±5%
R136, R137, R237	07-50100-10	RF10, 10Ω, 1/4W, ±5%
R236	07-50100-20	RF10, 10Ω, 1/4W, ±5%
R151	07-50100-01	RF10, 10Ω, 1W, ±5%
R251	07-50100-11	RF10, 10Ω, 1W, ±5%
R130, R230, R231	07-50820-11	RF10, 82Ω, 1W, ±5%
R131	07-50820-02	RF10, 82Ω, 1W, ±5%
R144, R145, R244, R245	07-40687-03	RGC, 0.068R, 3W, ±5%
INDUCTORS		
L11, L21	08-01005-00	0.5uH
POTS		
VR301, VR302	09-02101-00	100R
VR12, VR22	09-02201-02	200R
VR13, VR23	09-02202-01	2KΩ
VR3	09-02103-00	10K
SWITCHES		
S41	11-05202-02	SK-22F03G7
RELAYS		
RL31, RL32, RL33, RL34, RL35, RL36, RL37, RL38, RL39, RL310	12-02101-02	JRC-27F/012/S
RL12/1, RL12/2	A12-03102-05	JQX-115F/024- 2HS4AF(144)(555)
CONNECTORS		
Main board--CB58	A14-35602-03	UL1015#16AWG Black,VH 3.96A-2Y plug, 130mm length , two pin wires.
J188	14-35601-00	UL1061#26AWG green, single wire, circle diameter 15mm, total length 73mm.
Main board--CB54, CB54	A14-32502-00	VH 3.96A-2Y plug, 16AWG, UL1015# red and white, 130mm length.
CB22 --- CZ22(L MAIN INPUT)	14-35602-00	UL1691#26AWG*1C(white), SCN-2Y pins, XHB-2Y plug, L=250mm
CB12 --- CZ12(R MAIN INPUT)	14-35602-01	UL1691#26AWG*1C(red), S CN-2Y pins, XHB-2Y plug, L=310mm
CB39---CZ79(RS232 BOARD)	14-35604-00	UL2547#26AWG*3C white/red/yellow or others, SCN-4Y pins, XHB-4Y plug, L=160mm
R-OUT	14-32502-01	UL 2468 , 16AWG, blue and white. 155mm length.
L-OUT	14-32502-02	UL 2468 , 16AWG, blue and red. 100mm length
TP1 TP2 TP3 TP4 TP10 TP11	13-10001-00	Test-1®
CB34	13-22009-00	LD2.0A-9A(PH-9A)
CB31	13-22015-00	LD2.0A-15A(PH-15A)
CB48 CZ12 CZ22	13-22502-00	XHB2.5A-2A
CB35, CB45	13-22503-00	XHB2.5A-3A
CB47	13-22510-00	XHB2.5A-10A
CB36	13-21212-01	CNT-FPC125-12-TS, 1.25mm, 12pin
CB37	13-22513-01	CNT-FPC125-13-TS, 1.25mm, 13pin
RCA31 RCA32 RCA33 RCA34	17-01006-06	6 holes red and white, gilt
PHONE2	17-02001-04	ST-323B-04 CKK-3.5-02-3P

PHONE1	J17-02002-00	PHONEJACK2
BINDING POSTS		
Binding Post Assy (Long)	02-03560-01	Hansong assembled
SPEAKER TERMINAL	J17-03002-17	CL159706N
Binding Post	77-185002-0	16-001-0439-93
BDP Pin(Long)	69-185002-0	HS4-C356-B12V1-M007
Spring Washer	63-020511-2	SPR5.4*8.5*1.1
Binding Post Assy (Short)	02-03560-02	Hansong assembled
SPEAKER TERMINAL	J17-03002-17	CL159706N
Binding Post	77-185002-0	16-001-0439-93
BDP Pin(Short)	69-185001-0	HS4-C355-B12V1-M006
Spring Washer	63-020511-2	SPR5.4*8.5*1.1
LINKS		
J1, J25, J28, J29, J34, J35, J36, J38, J39, J41, J42, J43, J46, J53, J58, J59, J63, J66, J72, J75, J84, J88, J97, J99, J102, J104, J106, J112, J113, J120, J122, J127, J29, J132, J138, J139, J150, J151, J152, J154, J165, J166, J172, J183, J185, J186, J187, J190, J204, J205	21-06500-00	L=5mm
J26, J40, J44, J45, J48, J50, J51, J52, J56, J57, J71, J73, J79, J81, J82, J87, J96, J98, J105, J115, J117, J125, J126, J128, J131, J135, J136, J141, J143, J145, J147, J149, J159, J163, J164, J175, J177, J178, J181, J193, J194, J199	21-06750-00	L=7.5mm
J3, J62, J77, J80, J86, J100, J103, J116, J118, J119, J121, J130, J153, J170, J179, J191, J195, J196, J203	21-06101-00	L=10mm
J11, J12, J27, J37, J61, J65, J89, J92, J101, J140, J142, J144, J146, J156, J157, J171, J174, J176, J180, J189, J192, J197, J198	21-06121-01	L=12.5mm
J4, J7, J47, J49, J54, J55, J60, J64, J76, J78, J108, J111, J134, J137, J160, J162, J168, J173, J182, J200, J201, J206, J209	21-06151-00	L=15mm
J13, J67, J68, J94, J95, J123, J158	21-06181-00	L=18mm
J5, J30, J31, J32, J33, J83, J85, J107, J124, J133, J155, J169, J202, J210	21-06201-00	L=20mm
J110	21-06221-01	L=22.5
J15, J17, J18, J19, J20, J21, J22, J23, J24, J69, J70, J74, J90, J109, J184	21-06251-00	L=25
J2	21-10750-00	L=7.5
J10, J114	21-10121-01	L=12.5mm
J91	21-10151-00	L=15
J93, J167, J207, J208, J213	21-10201-00	L=20
J6, J148	21-10251-00	L=25
J8	21-10301-00	L=30
ASSY HEATSINK		
Used on KSC2690	61-023208-0	Screws,BTB3*8,black
Used on R467,R439	61-023208-0	Screws,BTB3*8,black
Used on CLAMPER	61-224516-1	Hexagon Socket Head Screw,GB/T70.1, M4*16
Used on CLAMPER	63-010408-0	Plain Washer,GB97.1-85 φ 4
Used on CLAMPER	63-020411-0	Spring Washer,GB93-87 φ4
CLAMPER	66-001009-0	HS4-C320-B009V1-M012
SECC	81-001004-0	SECC-N4 1219*530*1.6
Main Heatsink	70-091004-1	6063 T5,HS4-C355- B009V1-M004 B
Heat Conductive Pad	78-001004-0	Sil-Pad K06-122
R467	07-70471-08	PTH9M04BF471TS2F333
R439	07-70471-09	PTFM04BE471Q2N34BO
Q119, Q219	31-02690-00	KSC2690AYSTU
Q114, Q214	J31-02121-00	2SA2121-O
Q115, Q215	J31-05949-00	2SC5949-O
METAL PARTS		
GND-BAR	69-019001-0	Busbar
GND-2	69-019003-0	Busbar

H1	70-091005-0	Heatsink,ALU 6063 BLACK
H2, H3	70-185002-0	HS4-C356BEE-B12V1-M009
H4 H5	70-019003-1	Heatsink, HS4-C352-B009V1-M011 D
H6,H7	70-002005-0	Heatsink,15×35mm F35
Used on Heatsink 4	61-023204-0	Self Taping Screws,BTB3X4
Used on Heatsink2,3	61-022510-5	Screws,IB-25100-1HE
Used on Heatsink1	61-022514-5	Screws,IB-25140-1HE
Used on Heatsink2,KSC2690,A1220(6)	61-022208-6	Screws,BTB2.6×8
Used on Heatsink2,2SA1930&2SC5171(4)	61-023106-0	Screws,STB3×6
Used on Heatsink1,2,3	62-010202-5	Nuts,M2.5
P1-L,P2-L,P3-R,P4-R	61-382003-5	RIVET,GB975-86-2.5×3
P5-GND	61-382003-5	RIVET,GB975-86-4x3.2
Cable Tie	84-001003-0	YJ-100

PCB-8: AMP SMD module board LEFT PART # 01-35602-00

CIRCUIT NO.	PART NO.	DESCRIPTION
	DIODES	
D23, D24, D25, D26	33-44148-17	LL4148
	TRANSISTORS	
Q26	31-01015-03	A1015
Q27	31-01815-03	C1815
Q22, Q25, Q202, Q204	J31-01312-00	2SA1312-GR
Q23, Q24, Q201, Q203	J31-03324-00	2SC3324-GR
Q28	31-01661-00	KTA1661-Y
Q29	31-04373-00	KTC4373-Y
	CAPACITORS	
C28, C29	26-39051-00	39pF, 50V, 5%, NPO
C22, C224	26-10251-10	1nF, 50V, 5%, NPO
C23, C24	06-10031-02	VSS, 10uF, 35V, ±20%
C203, C204	06-22011-05	VSS, 22uF, 16V, ±20%
	RESISTORS	
R254, R255	07-90100-00	10Ω, ±5%
R215, R216, R272, R273	07-91509-00	15Ω, ±1%
R249	07-96809-00	68Ω, ±1%
R203, R206, R219, R220	07-98209-00	82Ω, ±1%
R211, R212, R259	07-91000-00	100Ω, ±1%
R269	07-93300-00	330Ω, ±1%
R201, R205	07-93902-00	39KΩ, ±1%
R223	07-94702-00	47KΩ, ±1%
R29, R210	07-95602-00	56KΩ, ±1%
R221, R222	07-91003-00	100KΩ, ±1%
R202, R204	07-92203-00	220KΩ, ±1%
	INDUCTORS	
L22	08-04101-00	100uH
	CONNECTORS	
CZ21(INserted TO CB21 ON THE MAIN BOARD)	13-12508-11	S006

PCB-7: AMP SMD module board RIGHT PART # 01-35608-00

CIRCUIT NO.	PART NO.	DESCRIPTION
	DIODES	
D13, D14, D15, D16	33-44148-17	LL4148
	TRANSISTORS	
Q16	31-01015-03	A1015
Q17	31-01815-03	C1815
Q12, Q15, Q102, Q104	J31-01312-00	2SA1312-GR
Q13, Q14, Q101, Q103	J31-03324-00	2SC3324-GR
Q18	31-01661-00	KTA1661-Y
Q19	31-04373-00	KTC4373-Y
	CAPACITORS	
C18, C19	26-39051-00	39pF, 50V, ±5%,NPO
C12, C124	26-10251-10	1nF, 50V, ±5%,NPO
C13, C14	06-10031-02	VSS, 10uF, 35V, ±20%
C103, C104	06-22011-05	VSS, 22uF, 16V, ±20%
	RESISTORS	
R154, R155	07-90100-00	10Ω, ±5%
R115, R116, R172, R173,	07-91509-00	15Ω, ±1%
R149	07-96809-00	68Ω, ±1%
R103, R106, R119, R120	07-98209-00	82Ω, ±1%
R111, R112, R159	07-91000-00	100Ω, ±1%
R169	07-93300-00	330Ω, ±1%
R101, R105	07-93902-00	39KΩ, ±1%
R123	07-94702-00	47KΩ, ±1%
R19, R110	07-95602-00	56KΩ, ±1%
R121, R122	07-91003-00	100KΩ, ±1%
R102, R104	07-92203-00	220KΩ, ±1%
	INDUCTORS	
L12	08-04101-00	100uH

CONNECTORS		
CZ11(INserted TO CB11 ON THE MAIN BOARD)	13-12508-11	S006
PCB-9: Preamp module board NSP, Part number 01-35504-00 both Line In and Line Out		
CIRCUIT NO.	PART NO.	DESCRIPTION
TRANSISTORS		
Q61, Q62	J31-00209-00	2SK209-GR
Q63, Q65	J31-01312-00	2SA1312-GR
Q69, Q610, Q611, Q612	J31-03324-00	2SC3324GR
Q64, Q66	31-01201-01	2SA1201-Y
Q67, Q68	J31-02881-01	2SC2881-Y
CAPACITORS		
C63, C64,	26-22051-00	22pF, 50V, ±5%,NPO
C69, C610	26-10151-00	100p, 50V, ±5%,NPO
C61, C62	26-22151-00	220p, 50V, ±5%,NPO
C613, C612	26-10251-00	1nF, 50V, ±5%,X7R
C65, C66, C67, C68	26-10451-00	0.1uF, 50V, ±10%,Y5V
RESISTORS		
R615, R616, R617, R618, R619, R620	07-90100-00	10Ω, ±5%
R61, R62	07-90221-00	220Ω, ±5%
R69, R610	07-94300-00	430Ω, 1%
R624, R625	07-90621-00	620Ω, ±5%
R67, R68, R611, R612, R622 R623	07-90102-00	1KΩ, ±5%
R613, R614	07-90103-00	10KΩ, ±5%
R63, R64	07-90225-00	2.2MΩ, ±5%
CONNECTORS		
CZ61(INserted TO CB32.CB33 ON THE MAIN BOARD)	13-12509-01	S006
PCB-4: Tone and Volume board 01-35603-00		
CIRCUIT NO.	PART NO.	DESCRIPTION
DIODES		
D319	33-44148-00	1N4148
D321	33-25819-00	1N5819
TRANSISTORS		
Q401, Q403	31-01015-00	2SA1015 GR
Q402, Q404	31-01815-00	2SC1815
CAPACITORS		
C302, C303	05-22113-01	220p, 1KV, ±10%
C327, C328	25-22361-01	22n, 63V, ±5%
C322, C321,C337, C338	25-10461-07	0.1uF, 63V, ±5%
C329, C330	25-10461-05	0.1uF, 63V, ±5%
C331, C332	25-22461-02	0.22uF, 63V, ±5%
C333, C334	25-10561-02	1u, 63V ±5%
C339, C340	06-10951-08	1uF, 50V, ±20%
C417 C418	06-47951-00	4.7uF, 50V, ±20%
C301	06-10051-00	10uF, 50V, ±20%
C325 C326	06-47021-06	47uF, 25V, ±20%
RESISTORS		
R403 R405 R406 R407	07-10102-50	1K, 1/6W, ±5%
R402 R404	07-10103-50	10K, 1/6W, ±5%
R387 R388	07-10203-50	20K, 1/6W, ±5%
R364	07-10513-50	51K, 1/6W, ±5%
R363	07-10513-51	RT14, 51K, 1/4W, ±5%
R327 R328	07-21800-50	180R, 1/6W, ±1%
R325 R326	07-23900-51	390R, 1/4W, ±1%
R331 R332	07-23900-50	390R, 1/6W, ±1%
R324	07-27500-50	750R, 1/6W, ±1%
R323	07-27500-51	750R, 1/4W, ±1%
R329 R330	07-21501-50	1K5, 1/6W, ±1%
R322	07-23301-50	3K3, 1/6W, ±1%
R321	07-23301-51	3K3, 1/4W, ±1%
POTS		
VR303 VR304	09-02103-00	10K
RT31 RT32	J09-01103-14	10KA
RT33	J09-01203-05	20KB
RT34	J09-01203-06	20K MN
LINKS		
J302 J304 J308 J309 J313 J314 J321	21-06500-00	L=5
J301 J303 J310	21-06750-00	L=7.5
J312 J320	21-06101-00	L=10
J307 J315 J316 J322	21-06121-01	L=12.5
J306	21-06201-00	L=20
J317	21-06221-01	L=22.5
J305 J318	21-06251-00	L=25
RELAYS		
RL311	12-02202-03	JRC-27F/005/S
CONNECTORS		
CZ37	13-22513-01	FPC1.25 13PIN, Pitch=1.25mm
METAL PARTS		

Self Taping Screw	61-023106-0	STB3*6
PCB-3: Keyboard 01-35607-00		
CIRCUIT NO.	PART NO.	DESCRIPTION
ICS		
IC73	03-00162-01	STC12C5A16S2-35I-LQFP44
IC76	03-00232-01	MAX232D+/MAX232ID+/MAX232CE+/MAX232ESE+
IC72	03-00038-40	HS0038B4
DIODES		
D710 D711 D712 D713 D714 D723 D724	33-44148-17	1N4148W-NR
D722	33-05819-01	1N5819HW-7-F, 40V, 1A
D71 D72 D73 D74 D75 D76 D77 D78 D708 D709 D716	33-50360-30	φ3, BLUE, BUL33842
D717	33-50565-12	Φ5 three color
TRANSISTORS		
Q722 Q723 Q724	31-01015-03	A1015
Q71 Q73 Q79 Q710 Q711 Q712 Q713 Q714 Q715 Q718 Q719 Q720 Q721 Q727	31-01815-03	C1815 SOT23
CAPACITORS		
C769 C770		N.I.
C79 C710	26-27051-01	27pJ, 50V, 0805, NPO
C758 C759	26-10151-01	100pJ,50V,0805,NPO
C771 C772	26-10251-01	1nK, 50V, 0805, X7R
C71 C714 C715 C716 C717 C718 C719 C720 C721 C724 C766 C767 C768	26-10351-01	10nK, 50V, 0805, X7R
C761	26-10451-10	0.1uK, 50V, 0603, X7R
C711 C760	26-10451-11	0.1uK, 50V, 0805, X7R
C722 C762 C763 C764 C765	26-10551-01	1uF, 50V, Y5V
C78	06-10011-23	CD70H,16V,10uF,±20%,105℃,F5.0
C723	06-10111-30	CD70H,16V,100uF,±20%,105℃,F5.0
RESISTORS		
R796 R797		N.I.
R708 R765 R767	07-90100-01	10Ω, ±5%,0805
R768 R769 R782 R783	07-90101-01	100Ω, ±5%,0805
R706 R712	07-95600-01	560Ω, ±1%, 0805
R746 R753	07-90102-01	1KΩ, ±5%, 0805
R709	07-91201-01	1.2KΩ, ±1%, 0805
R725 R726 R727 R728 R759 R788 R789 R798	07-92201-01	2.2KΩ, ±1%, 0805
R718 R719 R720 R721 R741 R742 R743 R744 R745 R747 R748 R749 R750 R751 R752 R754 R755 R756 R760 R761 R776 R777 R790 R791	07-90472-01	4.7KΩ, ±5%, 0805
R784	07-90512-01	5.1KΩ, ±5%, 0805
R701 R704 R707 R710 R713 R714 R716 R72 R73 R74 R75 R76 R77 R723 R724 R730 R731 R732 R733 R734 R735 R736 R737 R738 R739 R740 R762 R763 R766 R773 R774 R775 R778 R779 R780 R781 R785 R793 R799	07-90103-01	10KΩ, ±5%, 0805
R770	07-90203-01	20KΩ, ±5%, 0805
CRYSTAL		
Y71	04-11102-00	11.0592MHz, CL=15pF
INDUCTORS		
L71	21-06500-00	L=5mm
CONNECTORS		
PHONE71	J17-02001-02	SCJ340R0GBS0B00
CZ75—CB35	14-35603-01	UL2547#24AWG*2C white/black/red,JC25-3Y bend pins ,XHB-3Y plug,L=650mm
CZ78—CB78	14-35606-00	UL2854#26AWG*5C white/red/yellow/green/blue or others,JC25-6Y bend pins,XHB-6Y plug,L=620mm
CZ71	14-35609-00	UL2468#26AWG*9C,white,J C20-9Y bend pins,PH-9Y plug,L=450mm

CZ76	14-35615-00	UL2468#26AWG*7C+8C,JC 20-15Y bend pins,PH-15Y plug,L=470mm
Switch		
S71, S72, S73, S74, S75, S76, S77,S79,S710 S711 S712	11-04101-05	5mm,Tact Switch
METAL PARTS		
IR Bracket	66-091004-0	HS4-C355-B009V1-M011
Sleeve 1P	75-062001-0	1P
MP PAD	75-091002-0	HS4-C355BEE-B009V1- P007
PCB-2: Power board 01-35605-10 AH or 01-35605-20 C		
CIRCUIT NO.	PART NO.	DESCRIPTION
ICS		
IC55	03-00317-00	LM317T
IC53	▲ A03-00817-04	PC817X2J000F
IC51	▲ 03-00274-00	TNY274PN
DIODES		
D52	33-30142-01	DB104S, 1A 400V
D510	33-30162-02	DB105S, 1A 600V
D533	33-44148-00	1N4148
D57	33-14309-00	4.3V, 0.5W, ±2%
D541	33-25819-00	1N5819,长引线
D59	▲ 33-20540-00	SR540
D58	▲ 33-20107-00	FR107
D58	▲ or 33-24006-00	UF4006
D536	▲ 33-26200-00	P6KE200A
D513	33-24004-00	1N4004
D56 D537	33-30142-00	DB104
D531 D532	▲ 33-60116-00	TIC116D/BT151-500R
D51 D55	▲ 33-30822-03	8A/200V
TRANSISTORS		
Q501 Q518 Q520 Q522	31-01815-03	C1815 SOT23
Q59 Q510 Q517 Q519	31-01015-03	A1015 SOT23
CAPACITORS		
C544	26-10351-00	10nK,50V,0603,X7R
C530	26-10411-00	0.1uF/16V, X7R
C557	26-10412-01	0.1uF/100V, X7R
C536 C550	24-10412-01	0.1u,100V,20%
C51 C52	25-10322-00	10n/250V 10%
C555	06-10011-00	10uF, 16V, ±20%
C531	06-10042-00	CD11H, 10uF/400V, 20%
C551	06-10111-00	100uF, 16V, ±20%
C533 C545	06-33111-01	CD110,330uF,16V,± 20%,F5.0,
C546	A05-22242-00	2.2nF, 400V(X1), 250V(Y1), ±5%
C53 C539	▲ A05-47242-00	4n7p, 400V, ±20%
C54	▲ A25-33422-00	MKP62, 275V, 0.33uF 10%
C523 C524	06-22261-02	RGA222M1JBK-1836, 63V,2200uF,±20%,105℃
C523 C524	or 06-22261-01	CD267,63V,2200uF,± 20%,105℃
C527 C552	06-33221-02	RGA332M1EBK-1625 ,25V,3300uF,±20%,105℃
C527 C552	or 06-33221-01	CD263X,25V,3300uF,± 20%,105℃
C517 C518	▲ 06-22361-01	22000uF/63V, 20%, two leaders, 105℃
RESISTORS		
R575 R579 R582	07-90102-00	1KΩ, ±5%
R580	07-90472-00	4.7KΩ, ±5%
R581	07-90103-00	10KΩ, ±5%
R567	07-90334-00	330KΩ, ±5%
R533	07-90105-00	1MΩ, ±5%
R561 R565	07-90101-01	100Ω, ±5%
R532	07-92200-01	220Ω, ±1%
R558 R559 R560 R562	07-90102-01	1KΩ, ±5%
R534	07-92201-01	2.2KΩ, ±1%
R566	07-90472-01	4.7KΩ, ±5%
R563 R564	07-90223-01	22KΩ, ±5%
R570	07-10101-50	100Ω, ±5%, 1/6W
R571	07-10102-50	1KΩ, ±5%, 1/6W
R544	07-10223-51	22KΩ, ±5%, 1/4W
R578	07-22550-00	255, 1/6W, ±1%
R577	07-29100-50	910, 1/6W, ±1%
R584	07-30109-20	RY21, 1Ω, 1/2W, ±5%
R531	07-40507-03	0.05/3W 5% CE
FUSES		
F51(C version)	▲ A20-12252-00	T2.5AL250V
F51(AH version)	▲ A20-12502-00	T5AL250V

Fuse Holder for F51	⚠	20-20000-00	HF-004
INDUCTORS			
L51	⚠	A22-00183-00	2x1.8mH,73A173-2XY-9330
L52	⚠	08-01100-00	LGB0810-10uH
T51(Standby transformer)	⚠	A22-00016-06	EE16,Ben-10
RELAYS			
RL51	⚠	A12-02101-01	DH1U 15A/250V 5V
CONNECTORS			
CB52 CB54 CB58 CB510	⚠	13-23902-00	VH 3.96A-2A
CB55 CB56	⚠	13-23903-01	VH 3.96A-3A(delete the centerneedle)
CB59	⚠	13-23903-01	VH 3.96A-3A(delete the centerneedle)
CB57	⚠	13-23903-01	VH 3.96A-3A(delete the centerneedle)
CB51	⚠	13-23907-00	VH 3.96A-7A
CB53 --- CB47(MAIN BOARD)		14-35610-00	UL1007#26AWG gray,SCN-10Y pins ,XHB-10Y plug,L=240mm
METAL PARTS			
H503		70-002005-0	15×35mm
H503		61-023204-0	BTB3X4
H501, H502		70-004003-1	Heatsink,L=60mm
Used on H501, H502		61-083515-0	SELF TAPING SCREW,MPW3×15
Used on H501, H502		62-010302-0	Nut,M3
Used for C53 C539 C546		78-001001-1	Sleeve Boot
PCB-6: Headphone board 01-35604-00			
CIRCUIT NO.		PART NO.	DESCRIPTION
RESISTORS			
R454, R455		07-30101-04	100Ω, 2W, ±5%
CONNECTORS			
JK41		17-02001-41	CK-6.35-02 9P (with nuts)
CZ45--CB45		14-35603-00	UL2468#26AWG*3C,JC25-3Y bend pins ,XHB-3Y plug,L=40mm
PCB-5: RS232 board 01-35609-00			
CIRCUIT NO.		PART NO.	DESCRIPTION
RESISTORS			
R792		07-10101-50	100R, 1/6W, ±5%
CONNECTORS			
CZ79		13-22504-00	XHB2.5A-4A
CZ78		13-22506-00	XHB2.5A-6A
CZ77		17-08009-00	DB9, 7906-9-F-B(with nuts)
METAL PARTS			
BRACKET		66-010010-0	SECC-N4 T=1.00
Used on BRACKET		61-023106-0	Screw,STB3×6
Others			
CIRCUIT NO.		PART NO.	DESCRIPTION
MAIN TRANSFORMER			
C VERSION	⚠	A18-35617-20	HA150C-0637
AH VERSION	⚠	A18-35617-10	HA150C-0638
CONNECTORS			
MAIN board (P-GND) --TONE board (P-GND)		14-35601-01	UL1015#16AWG black,L=30mm
CB56---Power Switch	⚠	A14-31502-12	VH 3.96A-3Y (deletecenter needle) plug,18AWG UL1672#, red/blue, 190mm length.
CB55---AC Inlet	⚠	14-35502-00	VH3.96A-3Y (deletecenter needle)plug,18AWGUL1672#, .red, 300mm length.
CZ37---CB37(Main BOARD to Tone BOARD FFC)		14-06613-01	13Pin,45mm,Pitch=1.25mm, same sides FFC.
AC INLETS	⚠	A17-07002-07	SS-7BA-4.0
AC INLETS	⚠	or A17-07002-00	3516-T1C02
ROCKER SWITCH	⚠	A11-01101-03	RF-1003-BB2, 10A 250V, TV-5
AC Outlets(AH)	⚠	A17-07002-10	JT-0467A
AC CORD (AH)	⚠	JA15-10125-01	JT-0467ALP-13W &,SVT 18AWG×2,Black 6'& LP-16
AC CORD (C)	⚠	JA15-10250-20	PE-224 & H05VV-F, 2× 0.75mm2,2C Black 6'& LS-20
METAL PARTS			
REAR PANEL AH		67-185001-0B	HS4-C356Bee-B12V1-SR01 HS4-C356Bee-B12V1-M004

REAR PANEL C	67-185002-0B	HS4-C356Bee-B12V1-SR02 HS4-C356Bee-B12V1-M008
FASCIA	70-185001-1B	HS4-C356Bee-B12V1-SF03 B HS4-C356Bee-B12V1-M001 B
END CAP L	70-185003-0	HS4-C356Bee_B12V1- M010
END CAP R	70-185004-0	HS4-C356Bee_B12V1- M011
TOP COVER	67-019004-8	HS4-C352-B009V3-M004 D
CHASSIS	66-185002-0	HS4-C356Bee-B12V1-M003
Spacer	69-091002-0	HS40-M-B009V1-M012
SUBFASCIA	66-185003-0	HS4-C356Bee-B12V1-M005
PCB SUPPORT 2	66-019004-0	HS4-C352-B009V1-M014
BASE COVER	66-001004-1	HS4-C320-B009V1-M004 B
TRANS DISC	66-001008-0	HS4-C320-B009V1-M020
TRANS BRACKET	66-001010-0	HS4-C320-B009V1-M013
SHIELDING BOX	67-091003-0	
PHONE BRACKET	66-185001-0	HS4-C356Bee-B12V1-M002
SHORTING PLUG	30-63200-00	HS4-C320-B009V1-M014 HS4-C320-B009V1-P006
Rear Panel Plate	67-185003-0A	HS40-C356-B12V1-SR06 HS40-C375-B12V1-M020
Rear Panel Plate	67-124007-0	HS40-C375-B12V1-M020
Rear Panel Plate	65-124007-0	HS40-C375-B12V1-M020
Used on top cover	61-023106-0	Self Taping Screw, STB3×6
Used on top cover and main transformer	61-084108-0	Self Taping Screw, STPW4×8
Used on main transformer	64-108060-1	Hexagon Head Bolt, GB/T 5783, M8×60
PLASTIC PARTS		
Power Button	74-123003-1	HS40-C725BEE-B12V1- P008 B
POWER BUTTON BEZEL	77-123004-1	HS40-C725BEE-B12V1- P006 B
2P Input Button Bezel	N77-132001-1	HS40-C245-B12V1-P002 B
DUO BUTTON	74-132001-0	HS4-C245-B12V1-P001
Volume Knob	73-014002-3	Same as C320BEE
Tone Knob	73-014001-2	Same as C320BEE
Volume Knob Bezel	77-091003-3	HS40-C355-B009V1-P003 D
Tone Knob Bezel	77-185001-0	HS40-C375-B12V1-P001 B
LED Lens Bezel	77-062001-1	LED Lens Bezel
LED Lens	76-062001-1	
IR LENS	76-076001-0	HS4-C315BEE_B009V1- P005
FOOT ASSY	87-010004-0	
FOOT	(75-010004-1)	HS4-T973-B009V1-P006 B
FOOT PAD	78-001002-0	HS4-C320-B009V1-P010
FASTENERS		
Self Taping Screw	61-023108-0	STB3×8
Self Taping Screw	61-023106-0	STB3×6
Screw	61-023506-0	MB3×6
Self Taping Screw	61-084108-0	STPW4×8
Self Taping Screw	61-023208-0	BTB3×8
Self Taping Screw	61-082204-6	BTPW2.6×4
Self Taping Screw	61-073108-0	STO3×8
Self Taping Screw	61-023206-0	BTB3×6
Nut	62-010802-0	M8
Spring Washer	63-020820-0	8mm
PLAIN WASHER	63-010816-0	GB97,M8
ACCESSORIES		
Version Label C	94-185003-1	HS40-C356-B12V1-SL05B
Version Label AH	94-185002-1	HS40-C356-B12V1-SL05B
Transformer Lable	94-001004-2	
Cable Tie	84-001003-0	YJ-100
Cable Tie	84-100001-0	YJ-150
Heat Shrinking Tube	78-000300-0	φ30×35mm
3mm Rubber Pad	86-009003-0	10×10×3mm
Rubber Pad	79-062001-0	20×6.5×7.5
LED Lens Gum	86-046001-0	3M Double Side Adhesive
Nonwavens	86-014001-0	15x5x0.3mm
CR Foam	79-185001-0	CR UL 94V- 0,black,48*16*6mm,

CR Foam	79-185002-0	CR UL 94V-0,black,48*16*6mm,
ACCESSORIES		
REMOTE CONTROL	J30-17250-00	SR-8
BATTERIES	30-22100-10	Meet 2006/66/EC instruction
Polybag	90-040002-0	60x90mm
Instruction Manual	30-43560-01	
PACKING		
CARTON BOX	88-185001-0A	534*422*216mm 7mm
EPE POLYFOAM	89-019001-3	EPS
POLYBAG	90-001001-0	630X440mm
MANU POLYBAG	90-001002-0	220X370mm
AC CORD POLYBAG	90-001013-0	105X280mm
Non-woven Cloth	90-019002-2	H=115 W=100 L=435
SERIAL NO LABEL	94-185001-0	60x10

Notes:	AH	C
Main transformer	A18-35617-10	A18-35617-20
AC CORD	JA15-10125-01	JA15-10250-20
AC OUTLET	A17-07002-10	N.I.
Version Label	94-185002-1	94-185003-1
REAR PANEL	67-185001-0B	67-185002-0B

C356BEE EXPLODED VIEWS

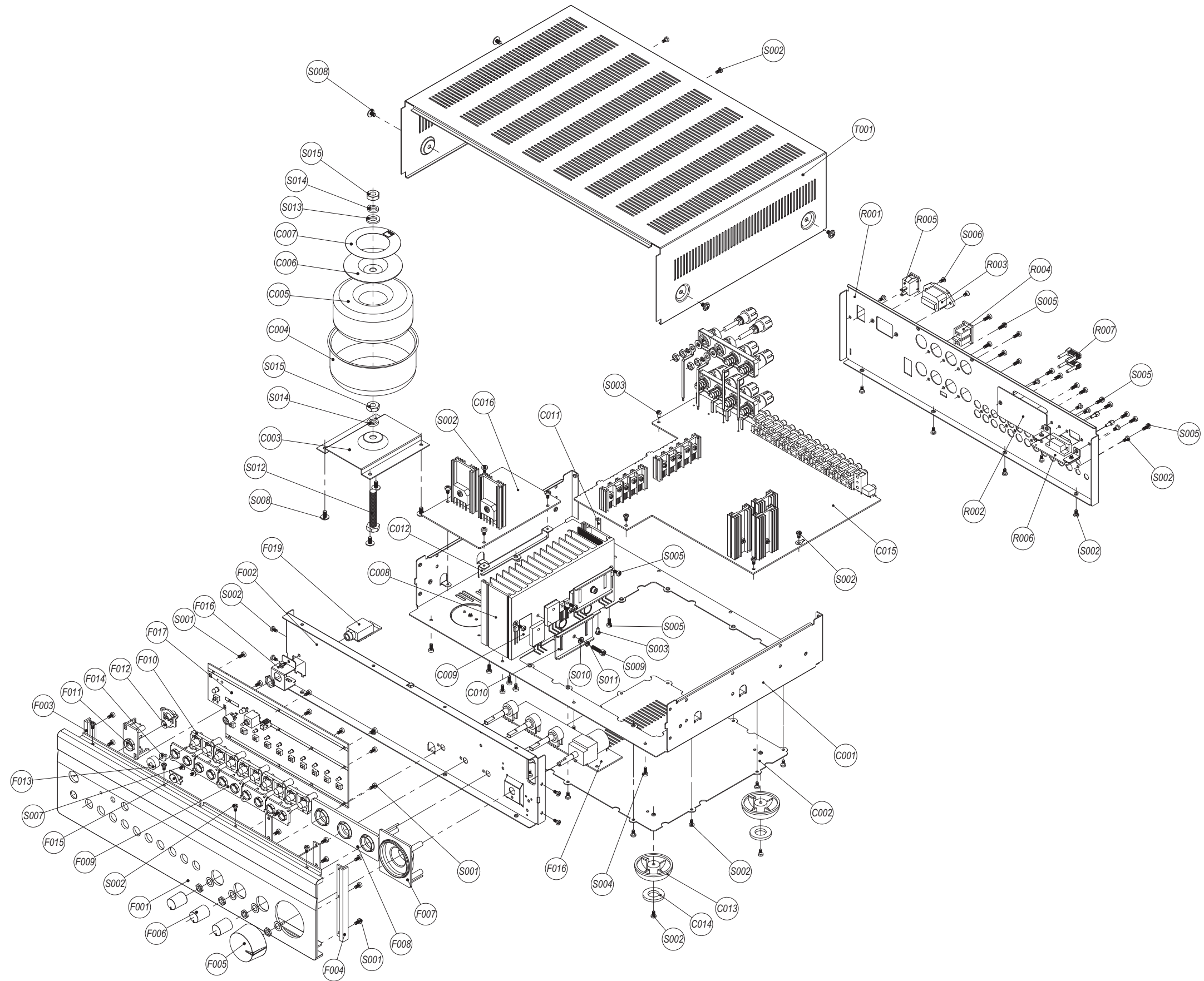

C356BEE EXPLODED VIEW PARTS LIST

REF.NO	PART NO.	DESCRIPTION	Qty.	REF.NO	PART NO.	DESCRIPTION	Qty.
C001	66-185002-0	Chassis	1	F013	77-062001-1	LED Lens Bezel	1
C002	66-001004-1	Base Cover	1		77-062011-1	LED Lens Bezel	Ti:1
C003	66-001010-0	Transformer Bracket	1	F014	76-062001-1	LED Lens	1
C004	67-091003-0	Shielding Box	1	F015	76-076001-0	IR Lens	1
C005	△ A18-35617-10	Main Transformer(AH)	1	F016	66-185001-0	Phone Bracket	1
	△ A18-35617-20	Main Transformer(C)	1	F017	01-35607-00	Key Board	1
C006	66-001008-0	Trans Disc	1	F018	01-35603-00	Tone and Volume Board	1
C007	94-001004-2	Transformer label	1	F019	01-35604-00	Phone Board	1
C008	70-091004-2	Main Heatsink	1				
C009	78-001004-0	Heat Conductive Pad	4				
C010	66-001009-0	Clamper	2	R001	67-185001-0B	Rear Panel AH	AH:1
C011	69-091002-0	Spacer	1		67-185002-0B	Rear Panel C	C:1
C012	66-019004-0	PCB Support 2	1	R002	67-185003-0A	Rear Panel Plate	1
C013	75-010004-1	Foot	4	R003	△ A17-07002-07	AC Inlet	1
C014	78-001002-0	Foot Pad	4	R004	△ A17-07002-10	AC Outlet	AH:1
C015	01-35601-00	Main Board	1	R005	△ A11-01101-03	Rocker Switch	1
C016	01-35605-10	Power Board(AH)	1	R006	01-35609-00	RS232 Board	1
	01-35605-20	Power Board(C)	1	R007	30-63200-00	Shorting Plug	2
F001	70-185001-1B	Fascia	1				
	70-185011-1B	Fascia	Ti:1	T001	67-019004-8	Top Cover	1
F002	66-185003-0	Subfascia	1		67-038002-5	Top Cover	Ti:1
F003	70-185003-0	End Cap L	1				
	70-185013-0	End Cap L	Ti:1				
F004	70-185004-0	End Cap R	1				
	70-185014-0	End Cap R	Ti:1	S001	61-023206-0	Self Taping Screws BTB3×6	21
F005	73-014002-3	Volume Knob	1	S002	61-023106-0	Self Taping Screws STB3×6	41+2
	73-020002-2	Volume Knob	Ti:1		61-023106-1	Self Taping Screws STB3×6	Ti:2
F006	73-014001-2	Tone Knob	3	S003	61-023506-0	Machine Screws MB3×6	2
	73-020001-1	Tone Knob	Ti:3	S004	61-023108-0	Self Taping Screws STB3×8	4
F007	77-091003-3	Volume Knob Bezel	1	S005	61-023208-0	Self Taping Screws BTB3×8	23
	77-091013-3	Volume Knob Bezel	Ti:1	S006	61-073108-0	Self Taping Screws STO3×8	2
F008	77-185001-0	Tone Knob Bezel	1	S007	61-022204-6	Self Taping Screws BTB2.6×4	2
	77-124011-1	Tone Knob Bezel	Ti:1	S008	61-084108-0	Self Taping Screws STPW4X8	4+4
F009	77-132001-1	2P Input Button Bezel	5		61-084106-2	Self Taping Screws STPW4X6	Ti:4
	77-132011-1	2P Input Button Bezel	Ti:5	S009	61-224516-1	Hexagon Socket Head ScrewM4×16	2
F010	74-132001-0	Duo Button	5	S010	63-010408-0	Plain Washer	2
	74-132011-0	Duo Button	Ti:5	S011	63-020411-0	Spring Washer	2
F011	77-123004-1	Power Button Bezel	1	S012	64-108060-1	Hexagon Head Bolt,M8×60	1
	77-123014-1	Power Button Bezel	Ti:1	S013	63-010816-0	Washers	1
F012	74-123003-1	Power Button	1	S014	63-020820-0	Spring Washers	2
	74-123013-1	Power Button	Ti:1	S015	62-010802-0	Nut,M8	2

SERVICE MANUAL

C 356BEE

**STEREO
AMPLIFIER**

**NAD ELECTRONICS LTD
TORONTO**