

TGSL 101

An introduction to the "Tesoro Golden Sabre Light"

The goal of this article is to consolidate some of the material from the extremely popular "TGSL" threads on the Geotech forum with hopes that it will encourage others to undertake this project and build confidence that could lead to a successful project.

While many have successfully completed this project, it is not recommended as a "beginners" project.

It assumes that one has had basic exposure to electronics including component identification, good soldering skills and access to proper test equipment. While it can be shown how to set up and tune the TGSL with only a DVM, troubleshooting *can* be extremely difficult without an oscilloscope.

The goal of this article is not meant to include every variation of the TGS but just one of the most popular. From there, the reader may learn and better understand how it works, how to setup, tune, troubleshoot, and extrapolate the difference in some of the other variations.

I take no credit for what is documented here, other than that I made an attempt at the consolidation of information from the many members who have contributed. I only claim that the information posted here is accurate and correct.

Complete details for this project including schematic, PCB layout, component placement, coil making and parts inventory must be downloaded from here:

<http://www.geotech1.com/forums/showthread.php?t=15710>

Don Bowers

Table of Contents

Induction Balance concepts.....	3
Explanation of Schematic	4
Circuit Construction	10
Coils - Construction and Tuning	10
Coils - Nulling	18
Coils - Advanced Nulling techniques.....	19
Alternate tuning methods.....	21
Coils - Completing Coil Enclosures.....	25

Induction Balance Concepts

Before any circuit explanation is offered we must understand what we are trying to accomplish.
Consider the diagram below:

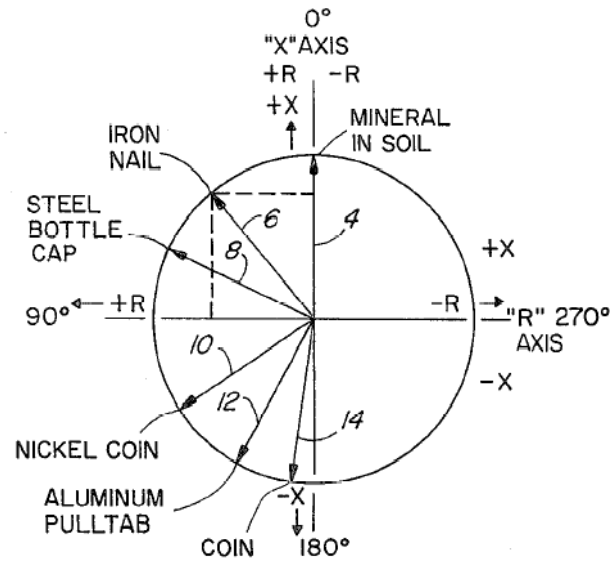

Conductivity scale

Taken from one of the original Tesoro patents, this represents the phase related target response of some common metals, showing two components - "R" and "X", or *conductive* and *magnetic*. Metallic items and the ground can have characteristics of both. Ideal Ferrite (purely magnetic) would be our 0° reference point.

This diagram is being used to illustrate a point. In order for an *single* channel Induction Balance metal detector adjusted to reject ground mineralization, it must accept anything that is "more positive" on the phase scale. Unfortunately, when a single channel IB metal detector is adjusted to tune out ground mineralization, iron will be accepted as well .

The way around this problem is to use *2 channels*. Consider the block diagram below. In this configuration, the phasing of $\emptyset B$ can be adjusted to match the induced phase shift of the receive signal caused by ground mineralization. This channel will then respond to all metals but not to the ground.

Likewise, the phasing of $\emptyset A$ can be adjusted to ignore unwanted metals, lower on the phase scale but this channel will still see a phase shift from the ground as well when the search coil is moved over the ground. Now only when both inputs to the comparator go positive at the same instant will there be detection. There are also filters employed (not depicted) that makes this a "motion mode" only detector. This is the basic scheme used by the TGS.

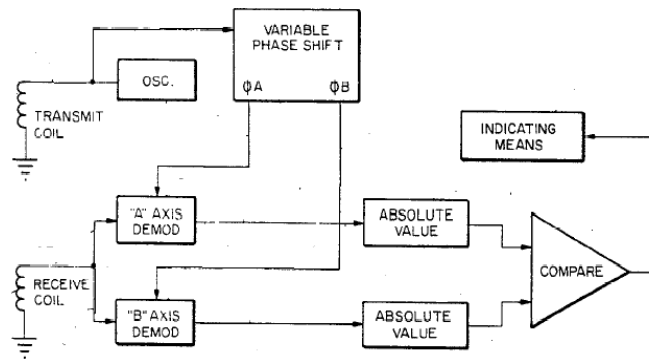

Further reading on this concept can be read here in the original Gifford (Tesoro) patent:

<http://www.geotech1.com/pages/metdet/patents/US4486713.pdf>

Schematic

The schematic can be broken down into about 12 functional blocks:

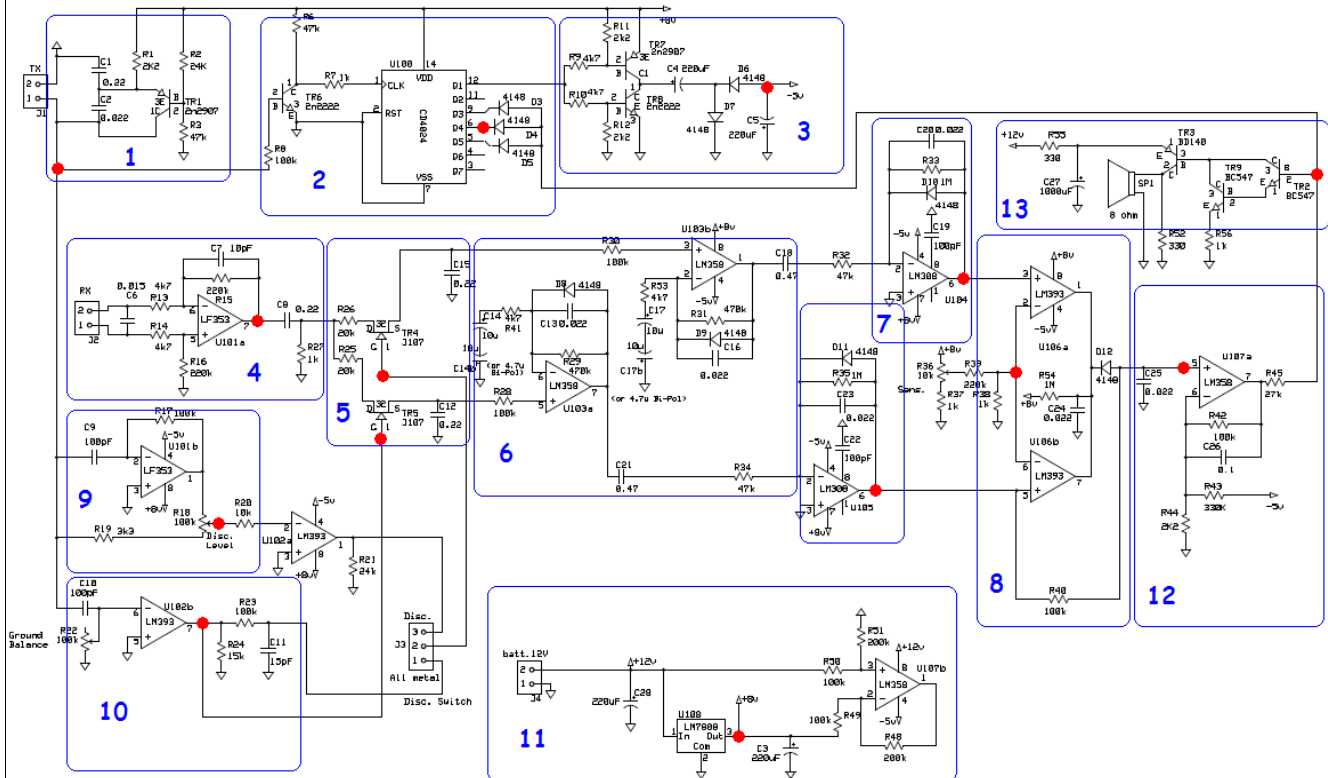

1. The basic Colpitts oscillator. Together with the transmit coil attached to J1, it provides a 14.5 kHz low power Tx signal to the coil, audio circuit, -5v converter and a signal to use as a phase comparison for the receive circuit. Tx amplitude should be in the 16V range.

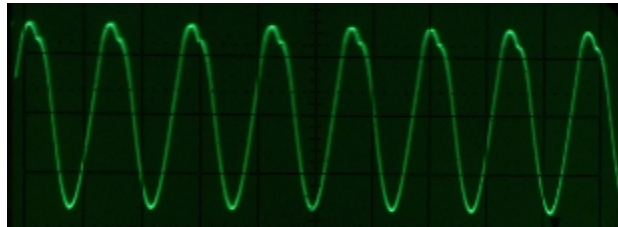

J1-1 5V and 20uS/Div

2. The CD4024 is a binary counter that provides a clocking signal to the -5V converter, block 3. It also provides a synchronous audio signal to the audio driver, circuit block 13. The 14.5kHz signal from the oscillator is divided by 32 down to about 453Hz by the CD4024. Furthermore, the 3 diodes connected to pins 5, 6 and 9 work together create a very short duty cycle to save on audio power.

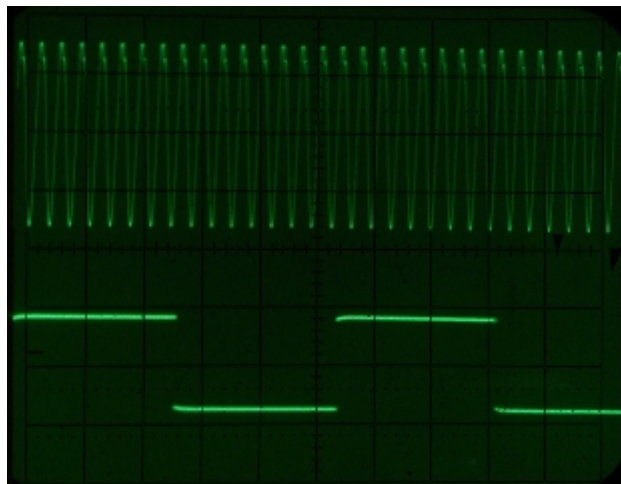

J1-1 (top) & U100 Pin 6 (bottom) 5V & .2mS/DIV

3. Converts +8V to -5V to be used as a negative voltage source.
This test point may not be exactly -5V but should be relatively close.

- 4.. This is the Rx preamp, U101a. Keep in mind the output, pin 7 as we will see this one again! Also, C6 is very important as this tunes our Rx coil. C6 in parallel with the Rx coil tunes our Rx circuit to about 16.12 kHz (off resonance). This is required to get the proper phase relationships for disc and ground balance to work properly.



*J1-1 Tx (top) 5v/Div & 20uS
U101 Pin 7 Rx (bottom) .01V/Div & 20uS*

5. TR4 and TR5 along with C12 and C15 make up our synchronous demodulators. They basically "gate" a sample of the the Rx signal by a phase related timing signal from block 9 (disc channel) and block 10 (ground balance channel). Furthermore, C12 and C15 turn our sampled signal into a small D.C. value that varies with any phase shift from the Rx signal from block 4.

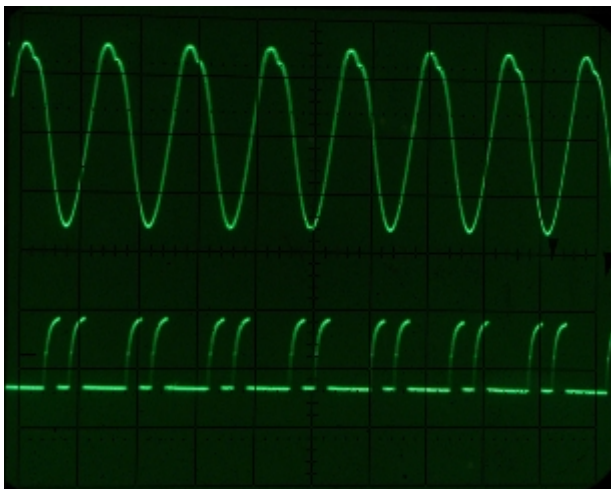

Gate - TR4 Disc set at Min

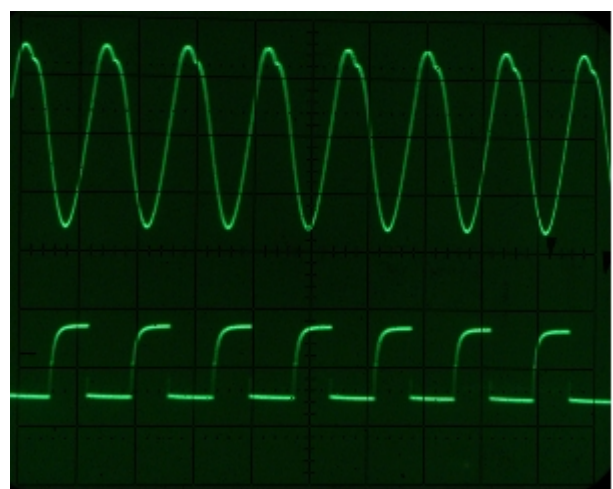

Gate - TR4 Disc set at Mid range

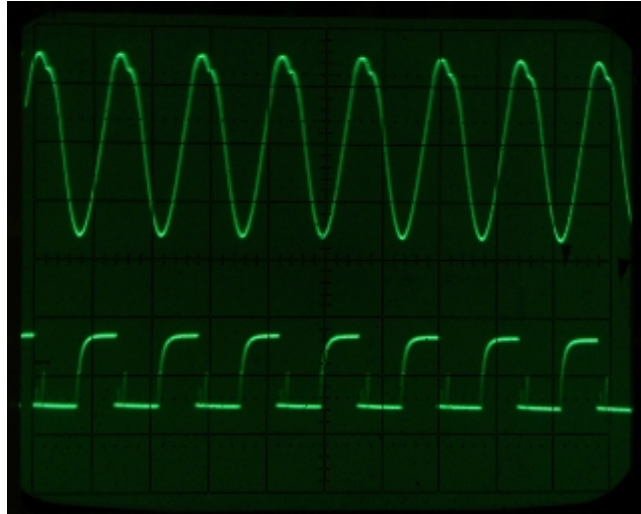

Gate - TR4 Disc set at Max

- U103a and U103b further amplify and filter our D.C. phase related signals. This functions as a *bandpass* filter with a frequency centered around 11Hz. This allows a low frequency pulse to pass to the next stage that should be in tune with the approximate sweep speed of the coil passing over a target, This is why proper sweep speed of the coil is important.

(Complements of Simon Baker)

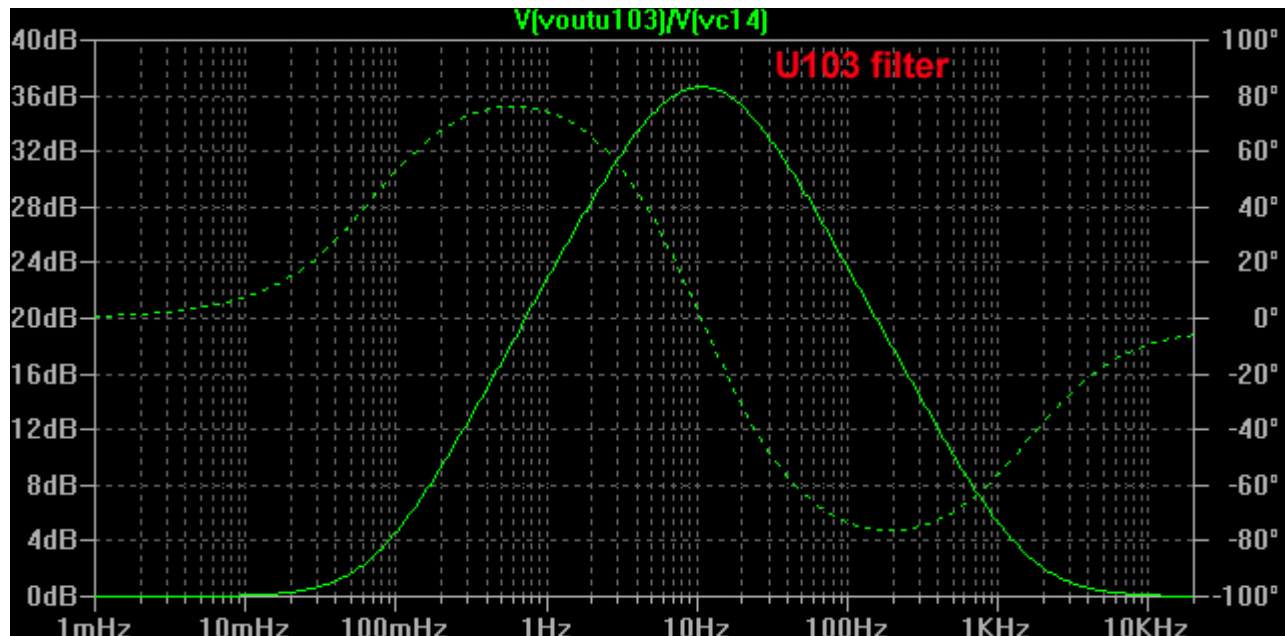

U103 frequency response

Solid lines are gain vs frequency

Dotted lines are phase shift vs frequency

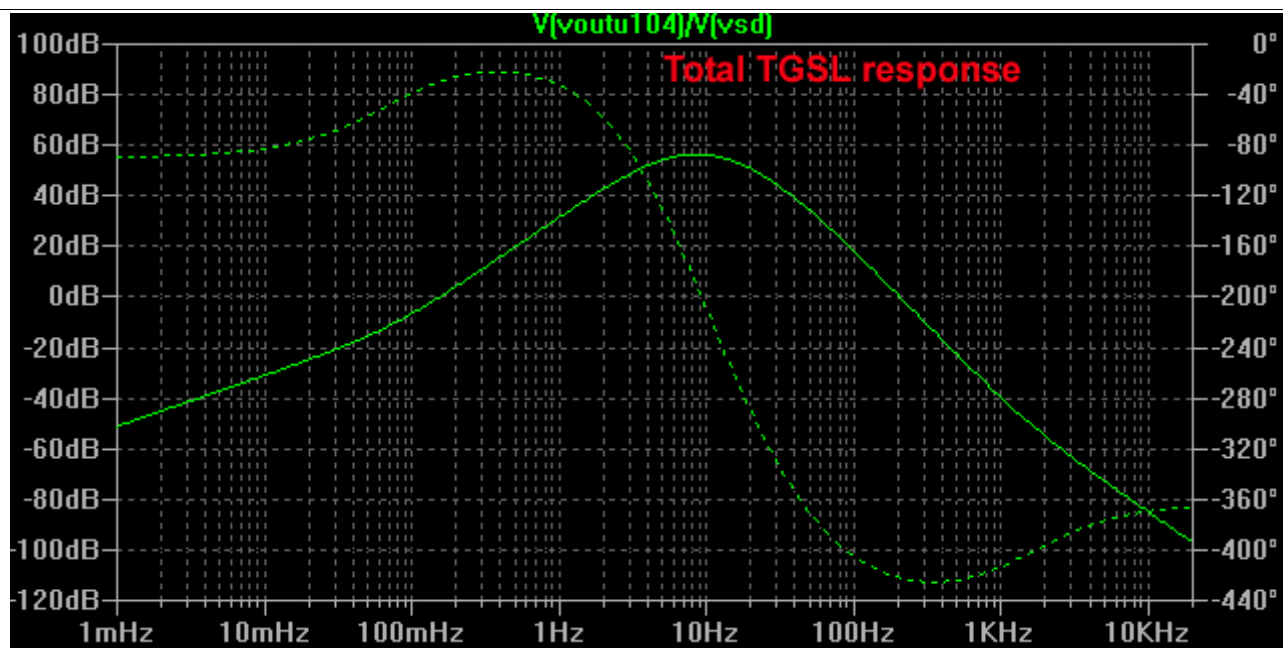

Total TGS response of all stages

7. Provides more D.C. amplification, filtering and limiting. Signals can be measured here as a D.C. Voltage that will swing + or - 1V or so as targets pass the coil. Keep in mind that U104 Pin 6 is the disc channel and U105 Pin 6 is the GB channel. Also, these test points can give a general indication of electrical "noise" in your environment. High noise levels can make your TGS perform poorly! In general, a measurement 5mV p-p of noise can be considered very good.

8. Here is where some interesting things happen that are not always obvious to the casual observer. Pins 2 and 6 are tied to a reference voltage and the LM393 compares the inputs on pins 3 and 5. The LM393 has the characteristic of being able to "sink" current from the opposite LM393 when the outputs are tied together. This type of IC is commonly referred to as an *open collector* design. So in order for the diode D12 to stop conducting (and ultimately provide forward bias for TR2 in block 13), BOTH U106 Pin1 and 7 must go high at the same time. Now in practice, the disc channel swings wildly as the loop is passed over the mineralized ground while the ground balanced channel only goes positive when the loop passes any type of metal. If the disc channel *agrees* with the ground balance channel at the same instant, we have detection!

 The voltage at the test point here should change from about .036V to close to 0v as the sensitivity pot is varied.

9. Provides for *positive* phase adjustment to the reference signal for the disc channel.

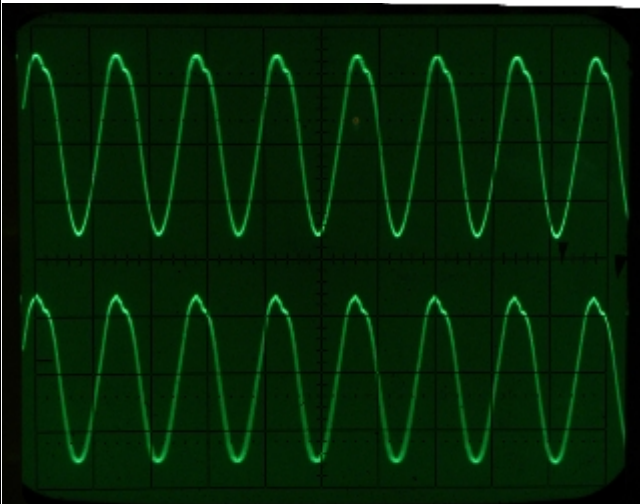

Test point 9 DISC set at Minimum

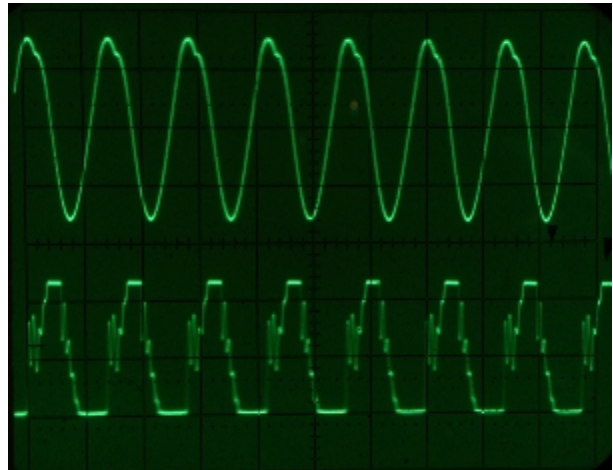

*Test point 9 DISC set at Maximum
Ugly.. but it's normal and it works!*

*Top trace is J1-1
Note Positive phase shift*

10. Provides for *negative* phase adjustment to the reference signal for the ground balance channel.

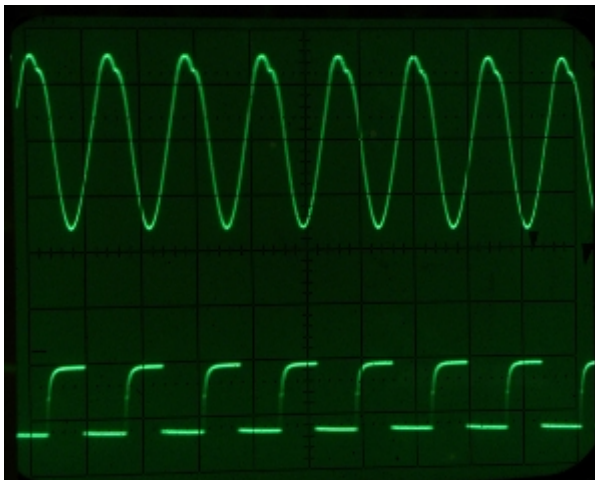

GB Potentiometer Min

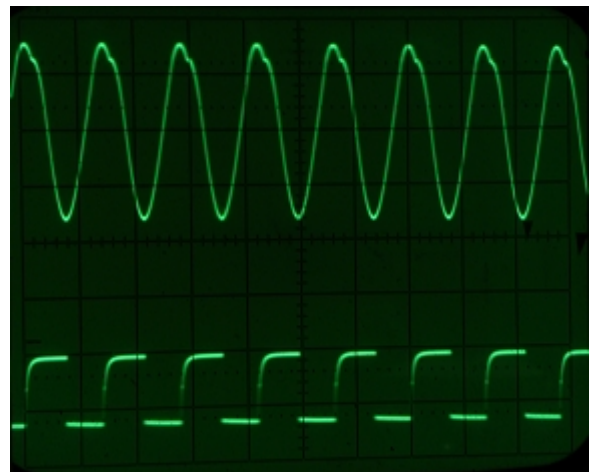

GB Potentiometer Max

*5V/DIV TR5 - FET Gate
Note Negative phase shift*

- 11 +8V Voltage regulator circuit. TP 11 should test at 8V. Provides a D.C. bias signal to TR2 in block 13 upon target detection. Normally will be at about 6V and will drop to 0V as targets pass the coil

13. Audio driver circuit. This test point varies from -5V to + Battery voltage as targets pass the coil

Circuit Construction

The information in the "TGSL Complete Details.pdf" is accurate and repeatable and can be found here: <http://www.geotech1.com/forums/showthread.php?t=15710>

If a good PCB is made or purchased and attention to the documented component selection is adhered to, you should have little problem in reproducing a working circuit of your own. At the time of this writing, a slight variation in complete kit form (minus coil) is also available and can be purchased here:

<http://www.silverdog.co.uk/>

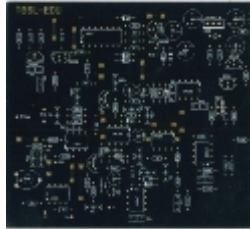

Coil Construction & Tuning

By far, coil making is the most challenging and will most likely determine the overall performance of the completed TGSL. Equally important is the final mechanical construction as the success of the project depends on it. Don't get discouraged though. With a little effort and attention to detail, it can be done!

Of course an original coil for the Tesoro Golden Sabre can be purchased, but that would defeat our purpose. Besides, we can build one that outperforms the original!

Below are the specifications for the most popular coil on the Geotech forum:

Diameter: 255mm x 137 mm (one coil)

Wire size: .25mm (30 AWG) enameled

Tx inductance: 6.0mH

Tx resistance: 18 - 25 Ohms

Tx resonance - About 14.5 kHz

Rx Inductance: 6.5mH

Rx resistance 18 - 25 Ohms

Rx resonance with 15nF - About 16.1 kHz

Regardless of the exact dimensions or number of turns, most importantly we *must* have the proper inductances and nulling or phasing will be off and proper ground balance setting and/or disc setting may not be possible.

Before attempting to wind coils, we *must* have a way to measure or calculate inductance, operating frequency or both. Most commonly used are inductance meters, oscilloscopes or frequency counters.

An alternate method will also be shown.

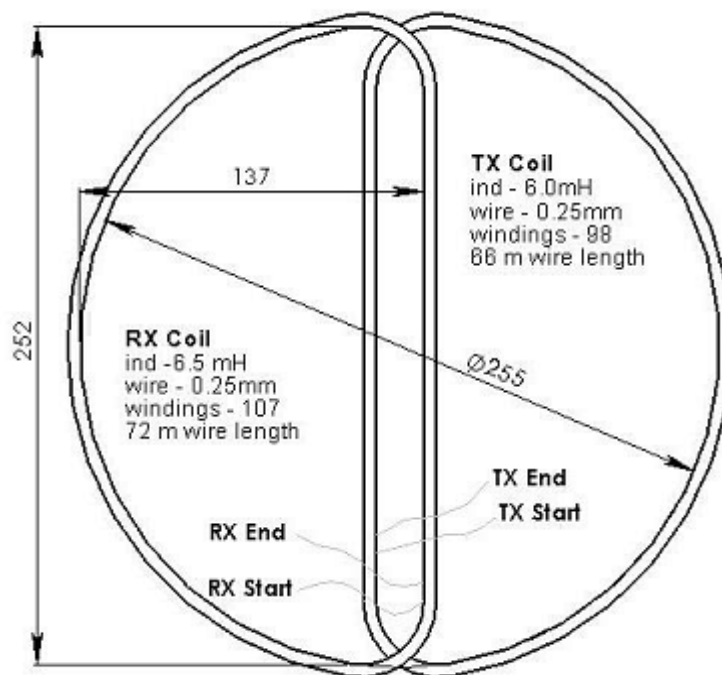

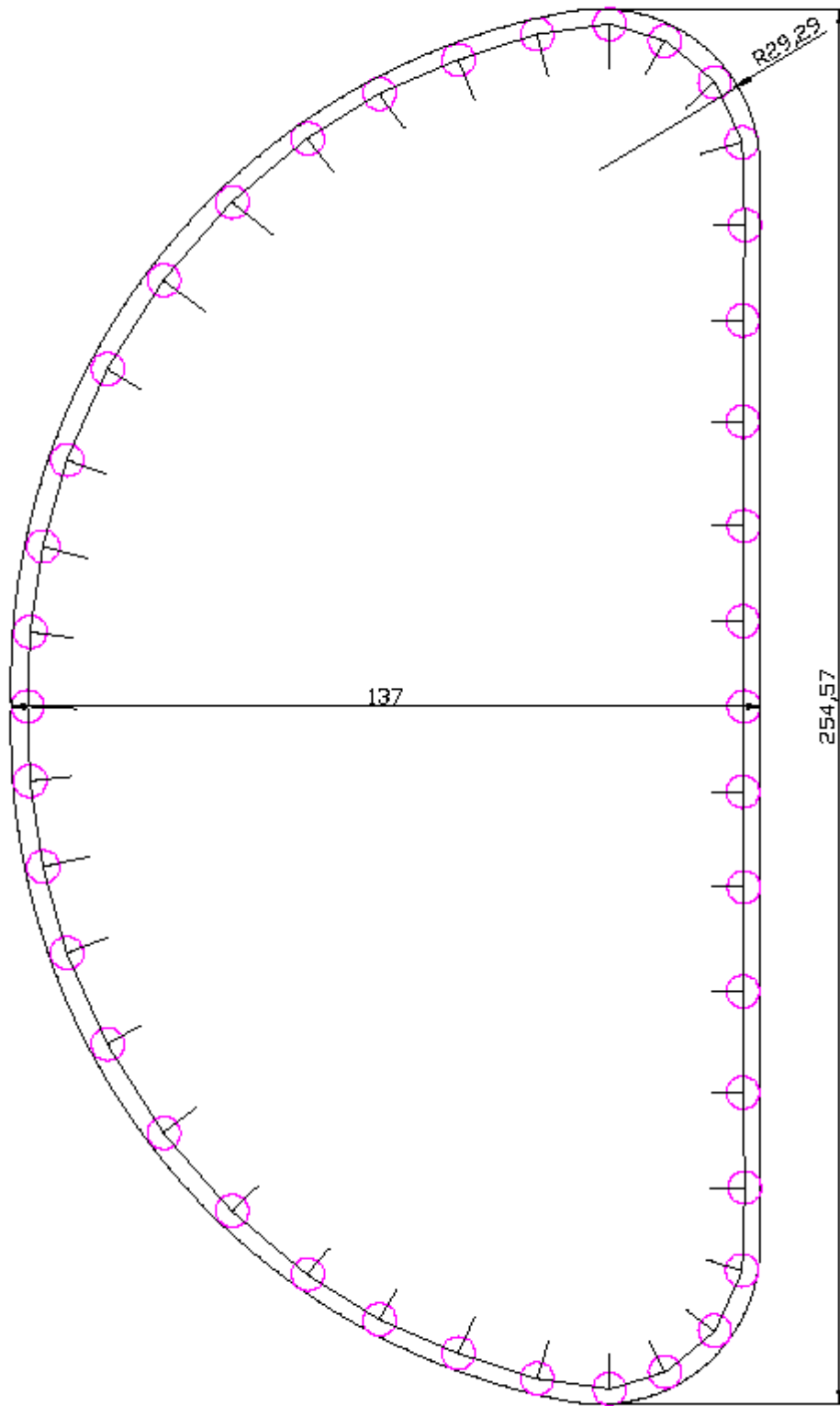

Basic Coil pattern below drawn by "Pip3c"

So, how many turns of wire? For this pattern, *I am going to suggest 99 turns for Tx and 104 turns for Rx (30 AWG enameled wire)*. In running the calculations for coil inductances a difference of just 5 turns is usually the answer for difference of .5mH between the two coils. I have been able to consistently build "good" coils this way.

Due to variations in wire and pattern building, your number of turns needed to achieve proper inductances may vary. This is just a suggested starting point.

One method of winding on a form is depicted below. It's basically two slabs of wood clamped together and the holes for the pattern are drilled. Then wooden dowel pins are driven into the holes. Between the two halves, spacers are used to allow a uniform thickness (4mm) - about the thickness of 2 U.S. Nickels. You *can* use just one slab of wood and insert dowel pins but it is advantageous to use *two* sides for a number of reasons.

1. When winding a coil on a single sided form, it is more difficult to wind coils consistently and once constrained, inductances are far more likely change.
2. When winding a coil on a double sided form, turns can be easily added or removed to achieve the proper inductance *before* constraining.

Double sided form



Once wire is put on a form, it's a good time to verify inductance. This can be done with an inductance meter. Or.. my favorite method is just attach the coil to your completed circuit board (J1) and measure the running frequency. The Tx should run at 14.5 kHz.

Next, half of the form must be removed and the wire must be constrained. I use simple dental floss. Note: If wire is wound on a two sided form tightly, very little change in inductance will occur once constrained. At most, it should increase by only .1 mH.

Build your Rx coil in the same manner, except for the number of turns. Also, to check your Rx coil, you can attach it to your completed circuit as well, but attach your Rx coil to J1 (the Tx circuit). Since this is 6.5mH, the oscillator should now run at 13.95 kHz. Again, this is just a quick check and will then be removed!

Form with half removed - Binding with string

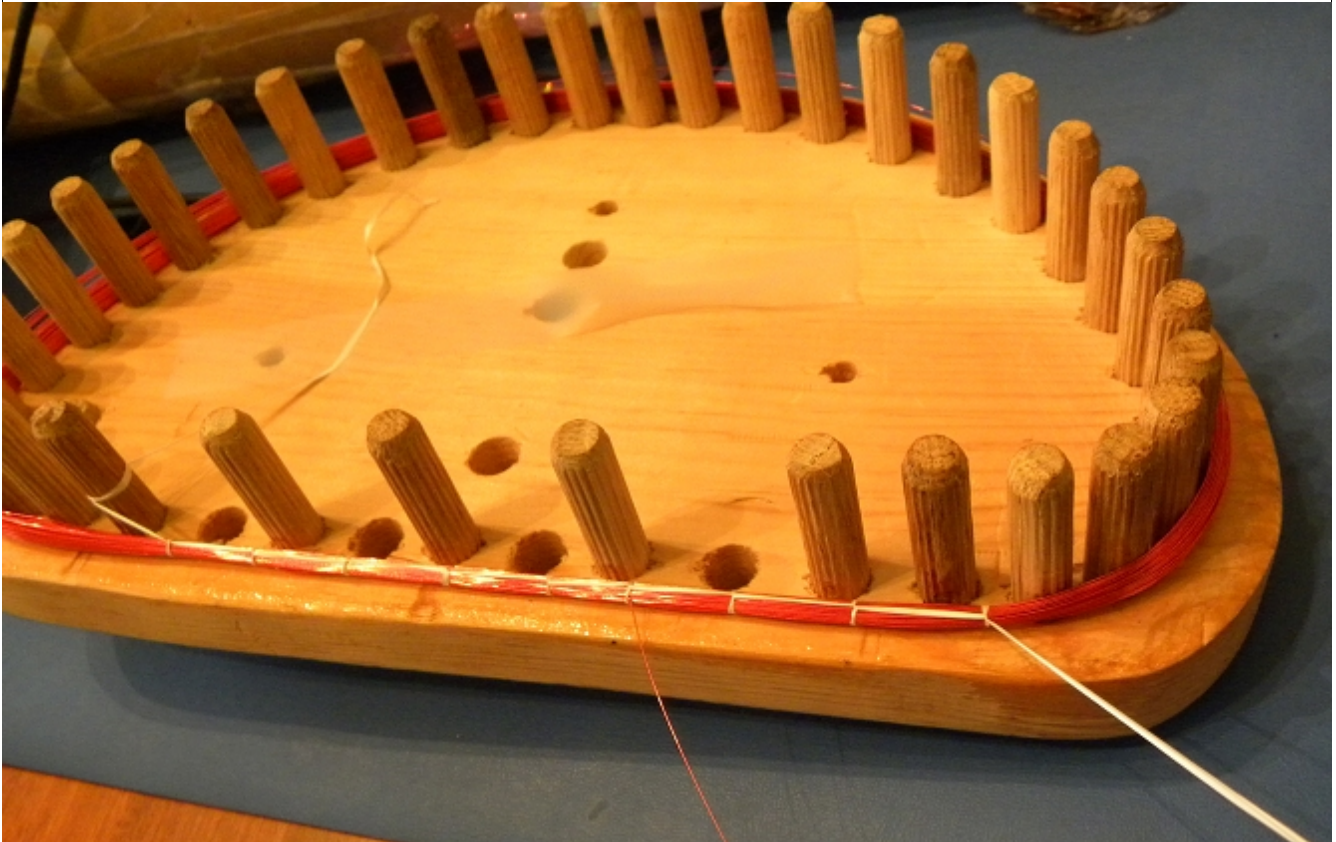

Following constraining the wires, they *must* be infused with cyan glue, so the coils become very stiff. This is very important as IB detectors are very unforgiving if not mechanically rigid!

Once dry, we must add an insulating layer of vinyl electrical tape. This is important as it helps prevent shorts to the shields that will be applied next.

Applying an Insulating Layer



Coil Shielding

Coil shielding is not optional. It is necessary to eliminate the effects of ground capacitance, static charges and to help eliminate noise from external electrical sources. The idea is for the coils to "see" the capacitance of the shields, which will be at the same potential as the *circuit* ground, and not earth ground, rocks or vegetation.

Choices for shielding material can be aluminum foil, aluminum, copper, or lead tape, "Scotch 24" shielding tape or metalized mylar (polyester film), just to name a few. Plain aluminum kitchen foil is usually the easiest to obtain and works just fine. I prefer metalized mylar as final sensitivity of the coil is noticeably better with this material. Sources of conductive mylar include mylar balloons, ribbons or bows from a party store, or reflective mylar survival blankets from a camping or outdoors shop. Keep in mind that in general, only ONE side of the mylar is conductive and must be in contact with any wires needed to attach to the cable ground!

Once insulating is finished, you can apply shielding in the following manner:

1. Wrap a thin, bare wire on top of the electrical tape but stop about 1cm short of completing a full circle. Leave enough of a "pig tail" to solder to the cable ground.
2. Wrap one spiraling layer of aluminum or mylar around the coil, making sure that the conductive side (if using mylar) makes contact with the bare wire. Again, make sure to stop short of completing a full circle!

Shield installed

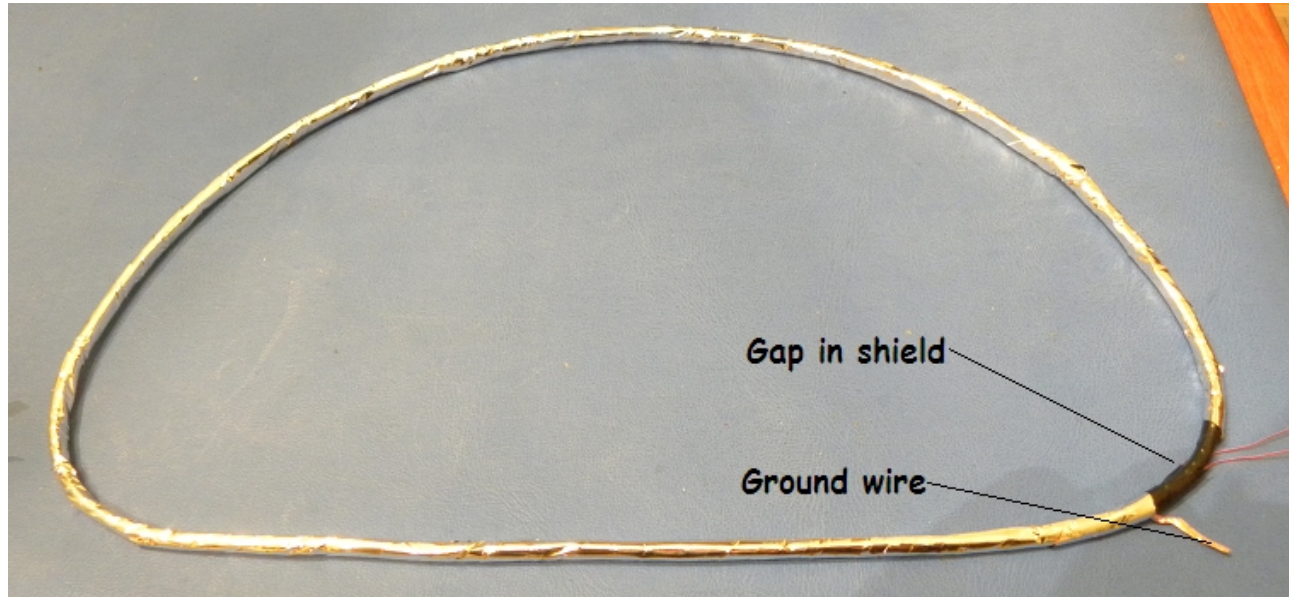

3. Apply a final layer of vinyl electrical tape.

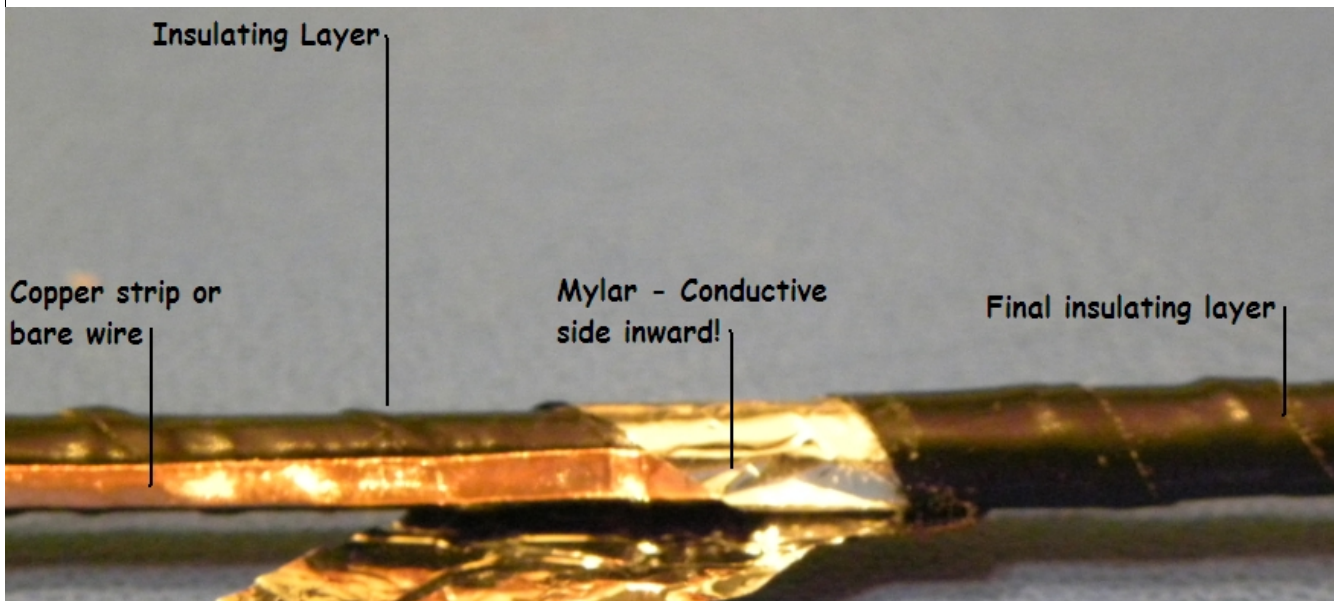

Optionally, you can view the *original* article on "TGSL Coil Making" by Ivconic here:

<http://www.geotech1.com/forums/showthread.php?t=15710>

Cabling and Coil Grounding

There are several options when it comes to coil cabling. Below are just two methods that work well. While testing my first couple of coils, I was disappointed with the performance of the TGSL when the ground was wet. The bottom image is my preferred method of coil ground and offers improved performance in wet grass.

USB - 2 Cable

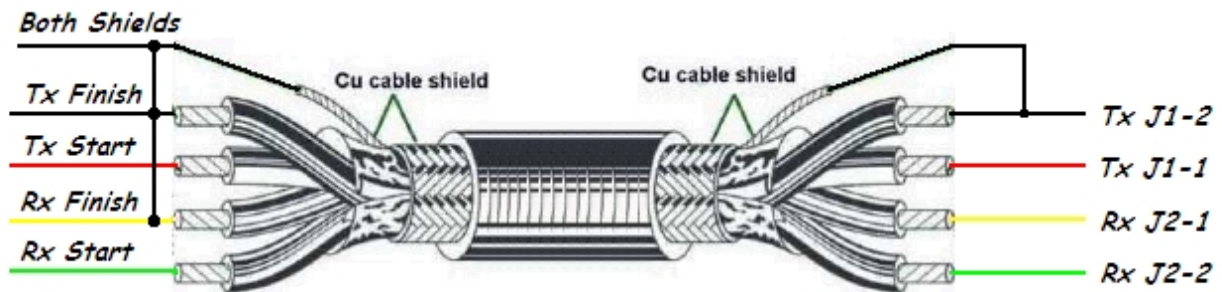

Cable wiring per TGSL coil making

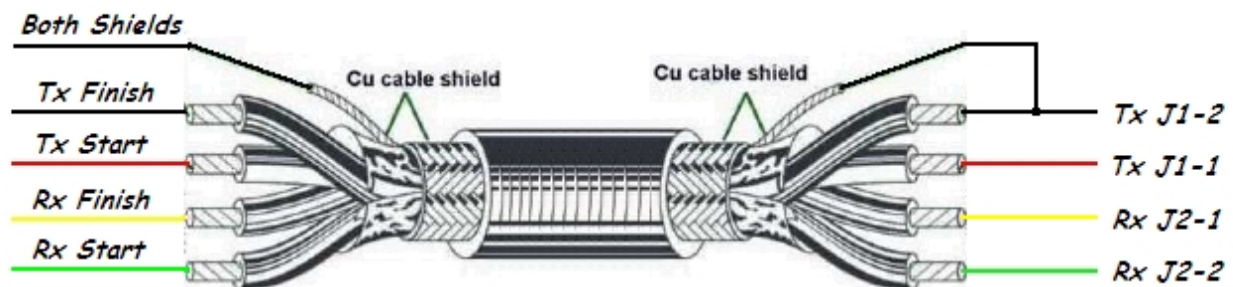

Cable wiring for improved performance in wet grass

Coil Nulling

More controversy seems to exist on coil nulling than any other aspect of this project. Basically, this is the process of overlapping the two coils so that they are in an "Induction Balance" state and the Rx coil will be under minimum influence of the alternating magnetic field of the Tx coil. This is because part of the Rx coil will be "inside" the Tx coil and part will be "outside" or part will see a positive magnetic flux and part will see negative flux at any instant in time. This may seem trivial, but I have seen so many new builders completely miss this concept.

Basic Nulling

To null coils, lay them out on a workbench *free from the influence of any metal objects*.

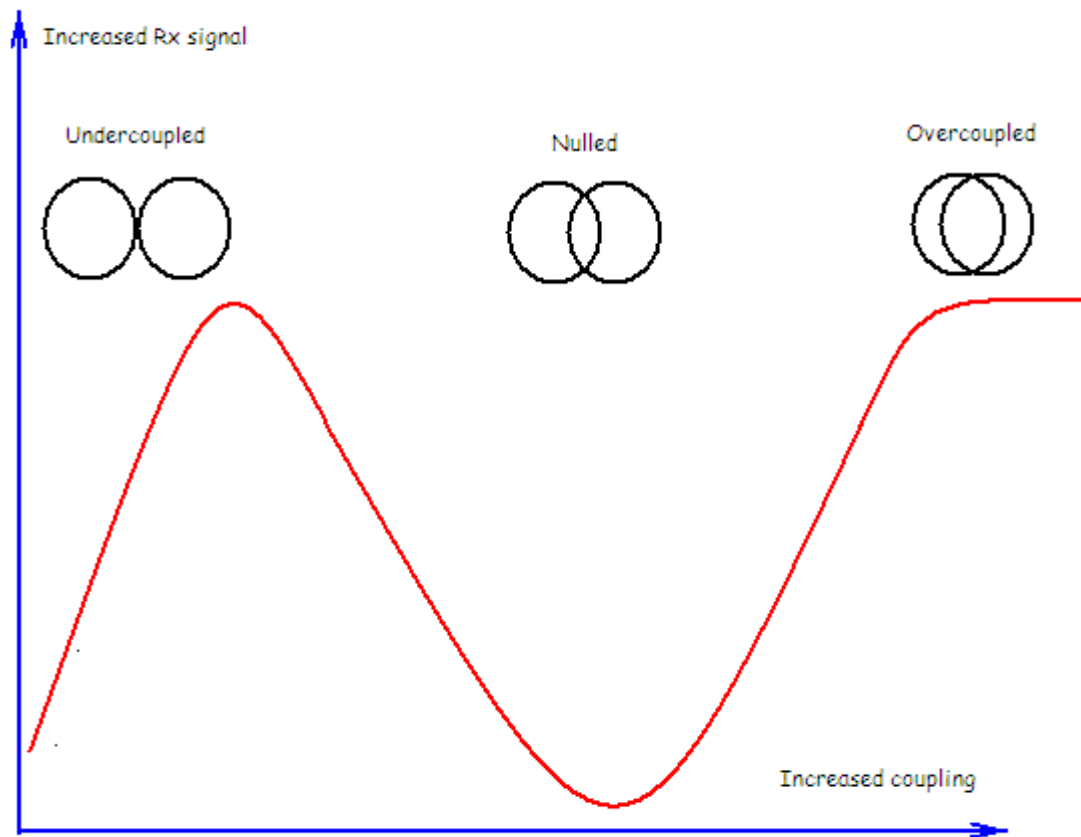

The final USB-2 cable to the circuit should be used and wires should be kept short as possible. Ideally, they should be placed inside the coil shells and the bottom coil should be secured. Power on the TGS and adjust coil overlap while monitoring U101a, pin 7 with a DVM in the A.C. setting. The goal is to find a sharp null in the voltage between U101a pin 7 and the PCB ground. You should be able to get the signal down to about 4mV but the actual reading may be subject to the frequency response of the DVM used.

When you have found the deepest null while positioning the overlap of the coils, it is time to secure the coils mechanically and check the ground balance setting. For this, you will need a small ferrite slug scavenged from an old radio or possibly a toroid. Verifying correct circuit operation would very difficult without a ferrite slug! Start with the TGSL switched to the all metal mode and set the GB pot fully Counter Clockwise. Start waving the ferrite slug over the coil and advance that GB pot slowly Clockwise until the ferrite slug is rejected or the sound starts to break up. Advancing too much further and silver may be rejected in the DISC mode! This will be a good place to start for rejecting the return signal associated with ground.

Possible problems: If ferrite cannot be rejected *or* accepted (in the all metal mode) at around the mid-range setting of the GB pot (or maybe just a little Clock wise of the mid-range setting) then possibly either the coils are not nulled *or* the difference in resonant frequency between Tx and Rx circuits is not correct (phasing is off).

If you have a dual trace oscilloscope, read on!

Advanced Nulling Methods

1. Connect the "A" channel of scope to U103 pin 5. - Set scope to DC setting.
2. Set the GB pot to the mid range position.
3. Start with coils apart and start to overlap.
4. Continue increasing overlap until the the D.C. Signal on Pin U103 pin 5 is 0 volts. Check the phase relationship between J1-1 (Tx signal) against U101 pin 7 (Rx signal). If resonant frequencies are correct, the Rx signal will now be lagging the Tx signal by approximately 20° .
(See Page #5, J1-1 and U101 Pin 7 traces)

Note: The Rx signal may not be at a minimum but should be *very close* to the null achieved in the "Basic Nulling" section above.

This is what is referred to as "Null phase" in the Geotech forum and corresponds to the sampling pulse from the Tx signal (gate of TR5) being *centered on the zero crossing* of the Rx signal coming from U101 pin 7.

The idea is, that at this setting, the influence of ideal ferrite on the Rx signal will be at a minimum - that is a slight change in signal amplitude caused by the "X" component of ferrite will have no effect. This is because any change in the positive and negative peaks of the sine wave would be equal and opposite and the net difference going into U103a would be 0. However, your ferrite sample is probably not ideal and neither is the ground, so we must still adjust the GB trimmer slightly to reject ferrite and ground. If nothing else, this procedure may help get the maximum range of adjustment from the GB potentiometer.

Null Phase

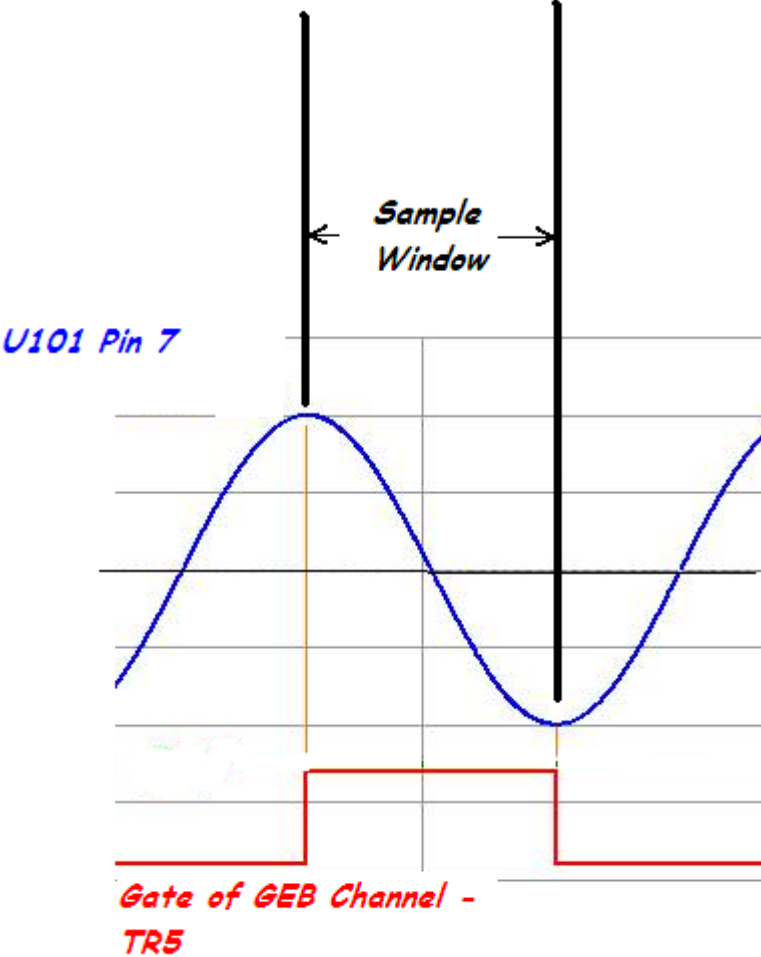

Alternate tuning methods

No way to measure the inductance of your coils? No problem! Just tune it with your ears.

Since the audio frequency is just divided down by 32 from the TGSL oscillator, we can adjust our frequency by just listening to the audio, and removing or adding turns to our coils. It's easy for me because my coils are made on a two sided form before binding. It's easy to peel off a few windings.

OK. so here is what to do:

Download this slick little audio oscillator to run on your PC.
<http://www.softpedia.com/progDownload-progDownload-65501.html>

DISCLAIMER: I got mine from the external mirror site. I scanned for viruses so it appears to be OK.

Then, set up your TGSL and null your coils. Crank up the audio oscillator on your PC and set it to a 453Hz square wave ($14.5\text{kHz} / 32 = 453\text{Hz}$). When the audio of your TGSL sounds the same as the audio oscillator, you should be tuned to 6.0mH for the Tx coil! It's fairly accurate..

Then.. switch your coils.. Tx for Rx and Rx for Tx We won't leave things that way.. just do it for testing.

Then, set up your TGSL and null your coils again. Now, adjust your audio oscillator for a 434Hz square wave ($13.9\text{kHz} / 32 = 434\text{Hz}$). Again, add or remove turns to your Rx coil (which is now connected to Tx) and tune your TGSL to the same frequency. Now, your Rx coil is set to 6.5mH!

What we just did is resonate each coil to 20nF, and assuming C1 and C2 are in spec, your Rx and Tx coils should be real close..

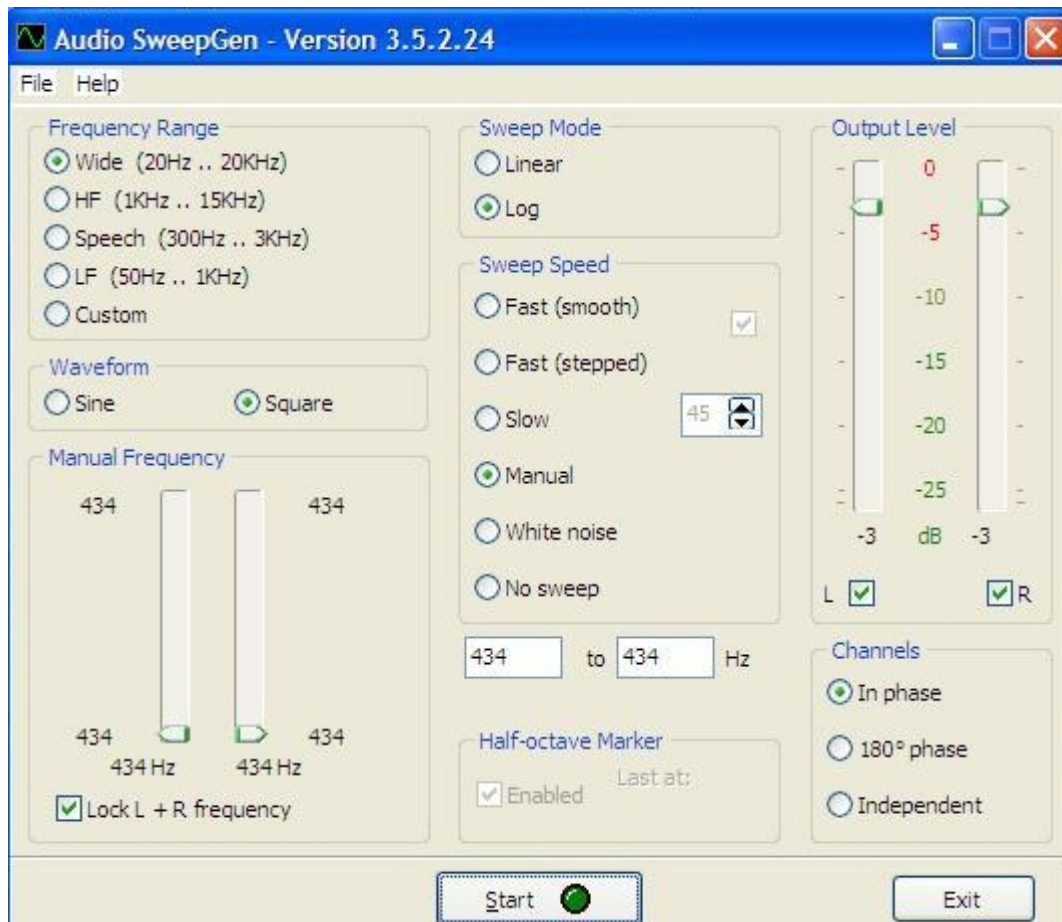

Final Assembly Considerations

There are options when building such as external or PCB mounted potentiometers. There are advantages to mounting things externally as adjustments can be easily made in the field. The only issue that I have come across was while mounting an external *GB* pot. The outside casing of the pot must be grounded to the PCB ground. This part of the circuit is very sensitive to hand capacitance but by grounding the case or the shaft will alleviate the problem. One other option is the addition of a volume control pot for a cabinet mounted speaker.

Anomalies

There are some behaviors that can be observed that are "normal" but need to be considered when setting up and troubleshooting. The two big ones that builders often come across are:

1. Motor boating - Can be annoying and is most often caused by being too close to power mains or 50 - 60Hz power. Can also be caused by having a magnetic speaker too close to the search coil or having weak batteries.
- 2 .Poor detection distance - This is fairly common and can be caused by electrical noise. Unfortunately this circuit may just function poorly around sources of electrical noise. The odd thing is that electrical noise does not always cause chatter through the speaker but just exhibits itself as poor performance for no apparent reason. It can most often be remedied by relocating the TSGL to a noise free environment.

Field tuning and setup - What to expect

Setup

DISC - Minimum
GB - Minimum
Sens - Minimum

Test targets needed

Ferrite loop stick or toroid
(used to simulate ground mineralization)
US Nickel
Aluminum Foil
Small nail
1 Euro or brass arcade token

1. Begin with the TGSL in the all metal mode. Power on TGSL and move ferrite sample across coil.
2. Advance GB pot clockwise until ferrite sample is rejected or is just breaks up. Ferrite should be rejected around mid range or slightly clockwise from the mid range setting. At this setting, iron should be easily accepted! This is a good setting for the majority of ground conditions.
Note: Advancing GB too far will cause silver to be rejected in the DISC mode!
3. Switch to DISC mode. Nails should now be totally or almost totally rejected. Any non ferrous items will be accepted.
4. Slowly advance DISC pot. This will cause Aluminum foil and eventually US nickels to be rejected. A good setting for the DISC pot is where small bits of foil are rejected.
5. Increase sensitivity to max and the TGSL should start to chatter. Decrease Sensitivity until it runs stable. At this setting, a correctly made TGSL in an electrically *quiet* environment should detect a 1 Euro coin at 30 - 34 cm in open air.