

Service Manual

Tuner Amplifier

Tuner Amplifier

SA-CH950

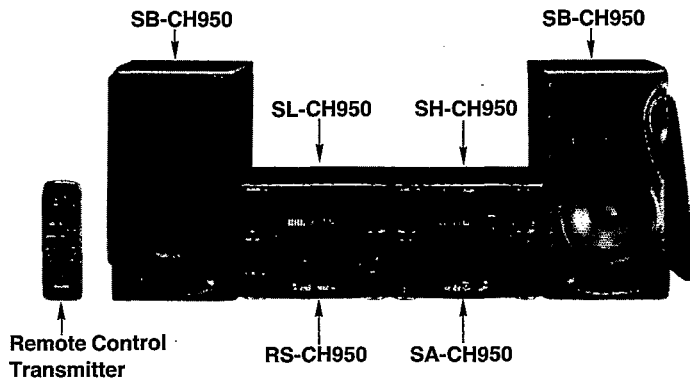

Because of unique interconnecting cables, when a component requires service, send or bring in the entire system.

Colour

(K) Black Type

Areas

Suffix for Model No.	Area	Colour
(E)	Europe	(K)
(EB)	Great Britain	
(EG)	Germany and Italy	
(GC)	Asia, Latin America, Middle Near East and Africa	
(GN)	Oceania	

SPECIFICATIONS

(DIN 45 500)

■ Main Amp. Section

Power output
 DIN 1 kHz THD 1%, both channel driven 2×60 W (6Ω)
 SFP, Dolby Pro-Logic mode 1 kHz THD 1%
 MAIN 2×55 W (6Ω)
 SURROUND 2×7 W (8Ω)
 Total harmonic distortion
 Rated power at 1 kHz 1% (6Ω)
 Half power at 1 kHz 0.07% (6Ω)
 Load impedance
 MAIN 6–8Ω
 SURROUND 8Ω
 S/N (rated power) 84 dB
 Frequency response 40 Hz–30 kHz (–3 dB)

■ FM Tuner Section

Frequency range 87.50 MHz–108.00 MHz (0.05 MHz steps)
 Sensitivity 1.8 μV (IHF, usable)
 S/N 26 dB 1.5 μV (75Ω)
 MONO 70 dB (75 dB, IHF)
 Stereo separation at 1 kHz 35 dB
 Antenna terminal(s) 75Ω (unbalanced)

■ AM Tuner Section

Frequency range MW
 For (E), (EB), (EG), (GN) areas 522–1611 kHz (9 kHz steps)
 530–1620 kHz (10 kHz steps)
 For (GC) area 531–1602 kHz (9 kHz steps)
 530–1600 kHz (10 kHz steps)

System: SC-CH950

LW
 For (E), (EB), (EG), (GN) areas 144–288 kHz, (9 kHz steps)
 For (GC) area 153–279 kHz (9 kHz steps)
 Sensitivity (S/N 20 dB)
 MW 500 μV/m
 LW 50 μV

■ Timer Section

Clock Quartz-lock type
 Function 24-hour programmable; Play timer (1 time)
 Rec timer (1 time)
 Sleep (120 min. 1 min. intervals)
 Setting 1 minute–23 hours 59 minutes (1 min. intervals)

■ General

Power consumption 190 W
 Power supply
 For (E), (EG) areas AC 50/60 Hz, 230 V
 For (EB), (GN) areas AC 50/60 Hz, 230 V–240 V
 For (GC) area AC 50/60 Hz, 110/127/220/240 V
 Dimension (W×H×D) 270×119×334 mm
 Weight 6.1 kg

Notes:

1. Specifications are subject to change without notice.
2. Weight and dimensions shown are approximate.
3. Total harmonic distortion is measured by the digital spectrum analyzer.

System	Sound processor	Tuner amplifier	Compact disc player	Cassette deck	Speakers
SC-CH950	SH-CH950	SA-CH950	SL-CH950	RS-CH950	*SB-CH950

* (E), (EB), (EG) areas... Made in PAES

Technics

CONTENTS

	Page		Page
●BEFORE REPAIR	2	●SCHEMATIC DIAGRAM	14~24
●PROTECTION CIRCUITRY	2	●PRINTED CIRCUIT BOARD DIAGRAM.....	25~29
●ACCESSORIES	2, 3	●WIRING CONNECTION DIAGRAM	30
●LOCATION OF CONTROLS	3, 4	●FUNCTION OF IC TERMINALS	31
●STACKING THE COMPONENTS	5	●BLOCK DIAGRAM	32~34
●CONNECTIONS	5~8	●REPLACEMENT PARTS LIST	35~40
●SETTING THE TIME OF DAY	9	●CABINET PARTS LOCATION	41
●DISASSEMBLY INSTRUCTIONS	10~13	●PACKAGING	42

BEFORE REPAIR

- (1) Turn off the power supply. Using a 10Ω, 10 W resistor, connect both ends of power supply capacitors (C701, C702) in order to discharge the voltage.
- (2) Before turning the power supply on, after completion of repair, slowly apply the primary voltage by using a power supply voltage controller to make sure that the consumed current at 50/60 Hz in NO SIGNAL mode is mode should be shown below with respect to supply voltage 110 V/127 V/ 220 V/240 V.

Power supply voltage	AC 230 V	AC 240 V
Consumed current 50 Hz	130~230 mA	115~215 mA

PROTECTION CIRCUITRY

The protection circuitry may have operated if either of the following conditions is noticed:

*No sound is heard when the power is switched ON.

*Sound stops during a performance.

The functions of this circuitry is to prevent circuitry damage if, for example, the positive and negative speaker connection wires are "shorted", or if speaker systems with an impedance less than the indicated rated impedance of this unit are used.

If this occurs, follow the procedure outlined below:

1. Switch OFF the power.
2. Determine the cause of the problem and correct it.
3. Switch ON the power once again.

Note:

When the protection circuitry functions, the unit will not operate unless the power is first switched OFF and then ON again.

ACCESSORIES

Check the packing carton for these accessories.

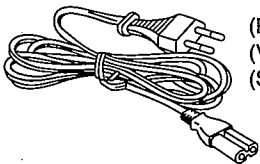

(RJA0019-2K) for (E), (EG), (GC) areas
(VJA0733) for (EB) area
(SJA173) for (GN) area

- AC power supply cord 1 pc.

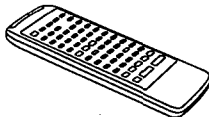

(RAK-SC707WH)

- Remote control transmitter 1 pc.



(REX0462)

- Flat cable 1 pc.

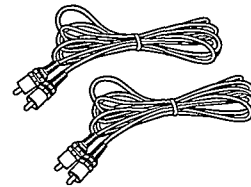

- Surround speaker cords 2 pcs.
(RJL1P001B25)

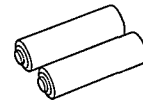

- Remote control batteries
UM-4, AAA, R03 2 pcs.
Note: These are available on sale route.

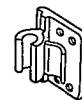

(SMA233-1M)

- Antenna holder 1 pc.

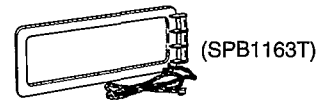

•LW/MW loop antenna 1 pc.

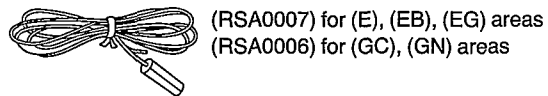

•FM indoor antenna 1 pc.

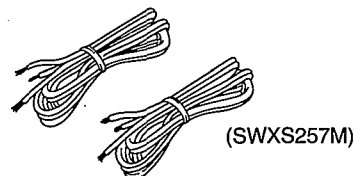

•Speaker cords 2 pcs.

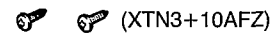

•Mounting screws 2 pcs.

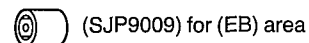

•Attachment plug 1 pc.

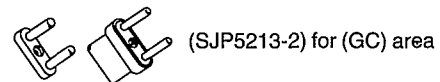

•Power plug adaptor 1 pc.

Note:

The configurations of AC power supply cord and FM indoor antenna differ according to area.

LOCATION OF CONTROLS

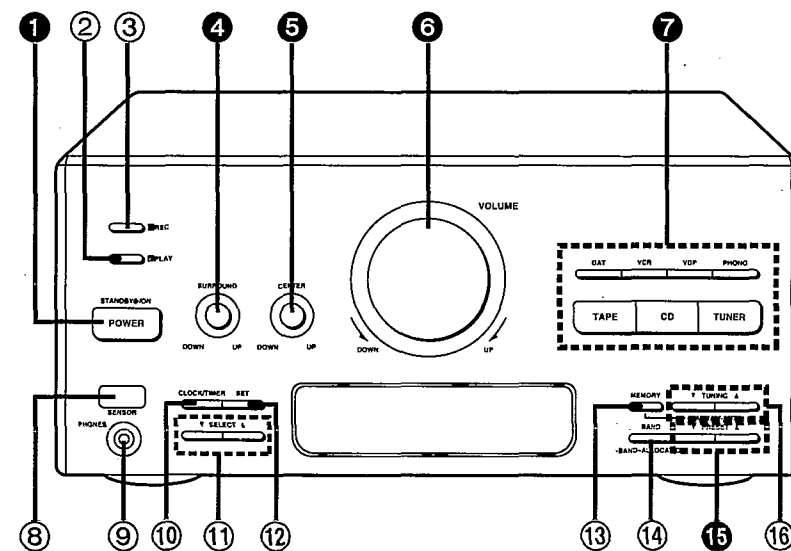

The functions indicated by the numbers with black background (for example ①) can also be activated from the remote control.

① Power "STANDBY \odot /ON" switch (POWER, STANDBY \odot /ON)

This switch switches ON and OFF the secondary circuit power only. The unit is in the "standby" condition when this switch is set to the STANDBY \odot position. Regardless of the switch setting, the primary circuit is always "live" as long as the power cord is connected to an electrical outlet.

② Timer play button (▶ PLAY)

Press to confirm, exit or reset the play timer.

③ Timer recording button (▶ REC)

Press to confirm, exit or reset the record timer.

④ Surround speaker level control (SURROUND)

Turn to adjust the volume level of the surround speaker.

⑤ Center speaker level control (CENTER)

Turn to adjust the volume level of the center speaker.

⑥ Volume level control (VOLUME)

Turn to adjust the volume level.
Note that --- dB is the lowest volume setting and 0 dB is the highest.

⑦ Input select buttons (TAPE, CD, TUNER, DAT, VCR, VDP, PHONO)

Press to select the sound source.

⑧ Remote control signal sensor (SENSOR)

Receives the signals from the remote control.

⑨ Headphones jack (PHONES) (\varnothing 3.5, 32 Ω)

Plug headphones cord into this jack.

⑩ Clock/timer button (CLOCK/TIMER)

Press to select the clock set mode or desired timer mode.

⑪ Timer select buttons (▼ SELECT ▲)

Use when setting the current time and timer.

⑫ Setting button (SET)

Press to set the present time in the clock mode, or set the various selection in the timer mode.

⑬ Preset memory button (MEMORY, -MANUAL, -AUTO)

Press to put a broadcast station into the memory.

⑭ Band select/allocation change button (BAND, -BAND -ALLOCATION)

Press to select the MW, LW or FM radio band.
Press and hold to change the MW frequency step.

⑮ Preset tuning buttons (▼ PRESET ▲)

Use to select channel number for a broadcast station which has been stored in the tuner's memory.

⑯ Tuning buttons (▼ TUNING ▲)

Use to tune in a desired broadcast station.

Display section

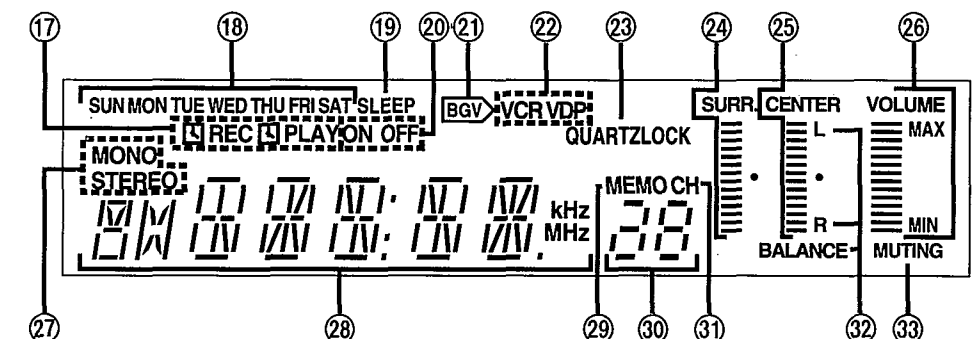

⑰ Timer mode indicators (▶ REC, ▶ PLAY)

▶ REC: Lights when you have set the record timer mode.
▶ PLAY: Lights when you have set the play timer mode.

⑱ Day indicators (SUN-SAT)

Shows the day of the week or the day the timer has been set for.

⑲ Sleep timer indicator (SLEEP)

Lights when you have set the sleep timer mode.

⑳ Timer on/off indicator (ON, OFF)

Lights together with the setting time to show the timer ON time and OFF time.

㉑ BGV (background visual) indicator (▶ BGV)

Lights when listening to audio sound source.

㉒ Visual source indicators (VCR, VDP)

Lights to show it is possible to enjoy BGV (Back Ground Visual) if you connect video deck or video disc player to this system.

㉓ Quartz lock indicator (QUARTZLOCK)

Lights when you precisely tune in a broadcast station.

㉔ Surround level display (SURR.)

Shows the volume level of the surround speakers.

㉕ Center level display (CENTER)

Shows the volume level of the center speaker.

㉖ Volume level display (VOLUME, MAX, MIN)

Shows the volume level.

㉗ FM STEREO/MONO indicator (MONO, STEREO)

"STEREO" lights when an FM stereo broadcast is being received. If you press FM mode button on the remote control to select monaural mode, "MONO" lights.

㉘ Alpha-numeric display

Shows the selected source, present time, and the contents of the timer setting, received frequencies, volume level.

㉙ Memory indicator (MEMO)

Lights when the preset memory button is pressed.

㉚ Preset channel display

Shows the preset channel you select.

㉛ Channel indicator (CH)

Lights when the unit is in the preset tuning mode.

㉜ Balance display (L, R, BALANCE)

Shows the left-right volume balance.

㉝ Muting indicator (MUTING)

Lights when you activate the muting mode.

■ STACKING THE COMPONENTS

Install the various components as shown below.

■ Horizontal stacking

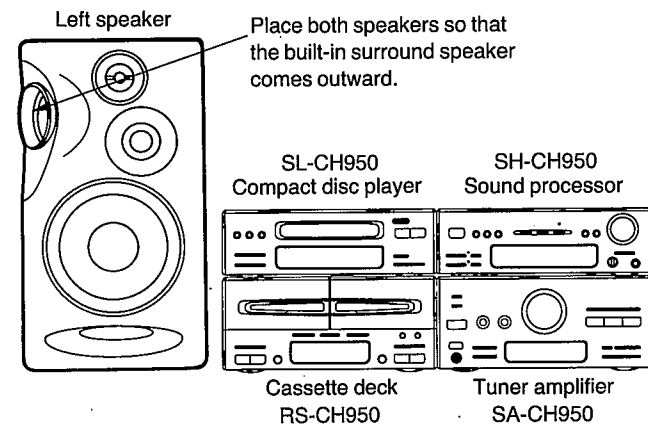

■ Vertical stacking

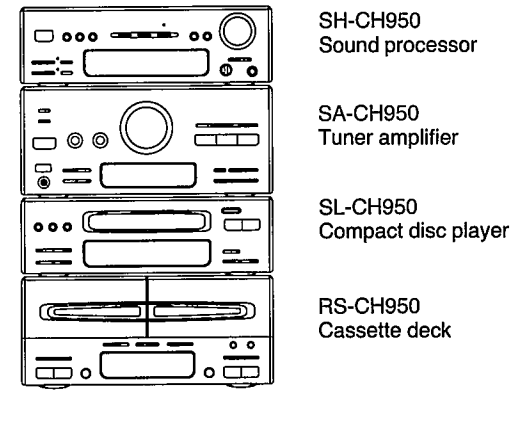

■ System layout

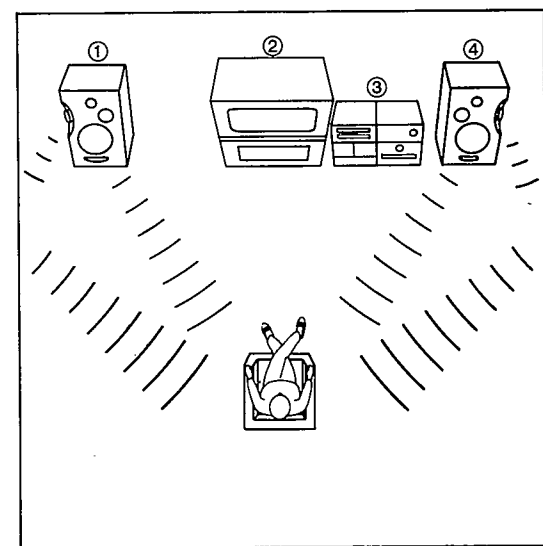

- ① Left speaker
- ② Television set (not included)
- ③ This system
- ④ Right speaker
- ⑤ Surround speaker (not included)

To produce a better stereo sound, install both speakers away from the system.
This speaker system has built-in surround speaker, so you can easily enjoy the surround sound.

■ CONNECTIONS

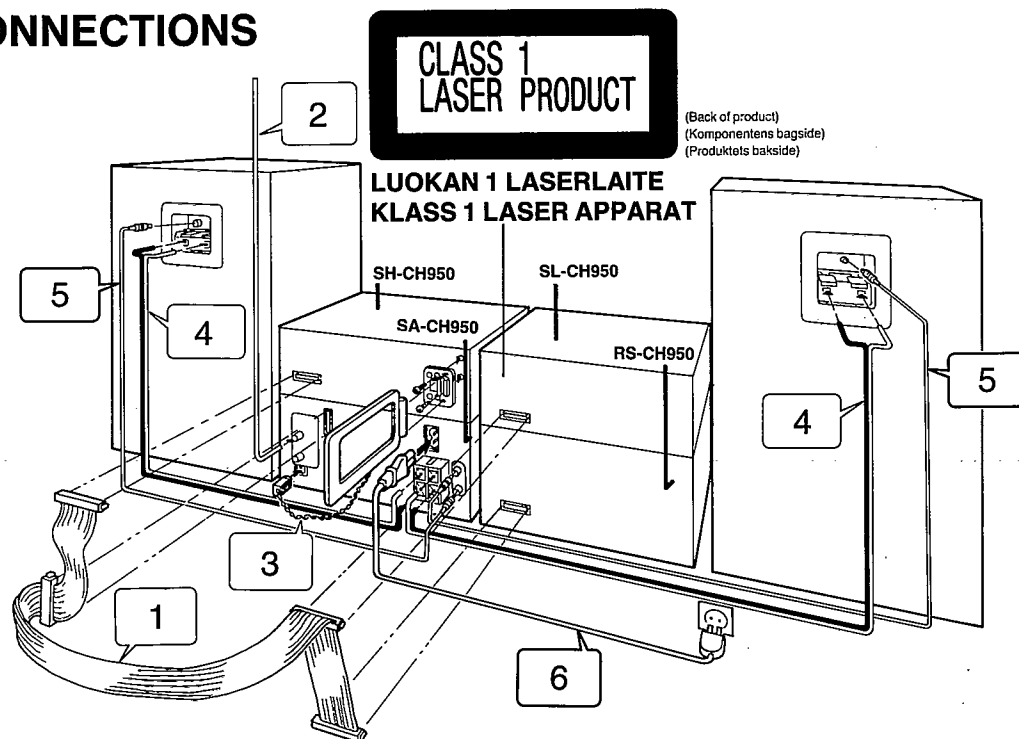

1 Connect the flat cable.

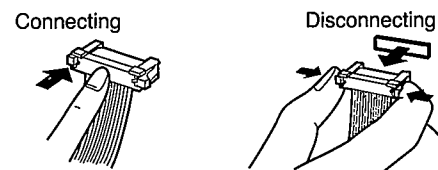

Hold the connector with the recessed part up and press in at the center until you hear a click.
First connect the blue-colored connector to the terminal of the sound processor (A), then connect the rest in the order B, C, D.
Route the cable horizontally (underneath the heat outlet grille) so that the side with the white-color lead is positioned at the front.

After connection, fold and press the cable as flat to the back of the unit as possible.

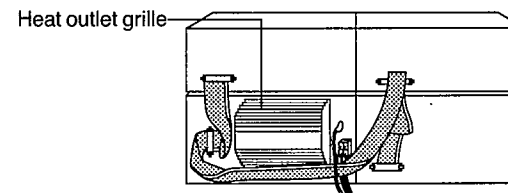

Do not try connecting or disconnecting the flat cable while the power is switched to ON.

3 Connect the LW/MW loop antenna.

1. Attach the antenna holder with screws (included) to the rear panel of the sound processor.
2. Clamp the antenna to the antenna holder and connect the antenna terminal to the rear panel of the tuner amplifier.
3. Position the loop for the best reception.

You may attach the LW/MW antenna holder to a rack or other structure.

Notes:

- To minimize noise pickup, keep the LW/MW loop antenna away from the speaker cable, power cord, and metal surfaces.
- For better reception, keep the LW/MW loop antenna cord along the heat outlet grille, and away from the flat cable.

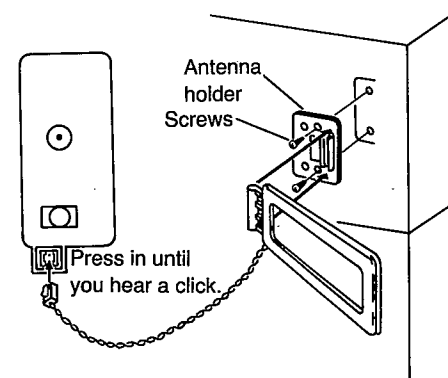

2 Connect the FM indoor antenna.

Install the antenna on a wall at a height and in a direction which result in the best reception.

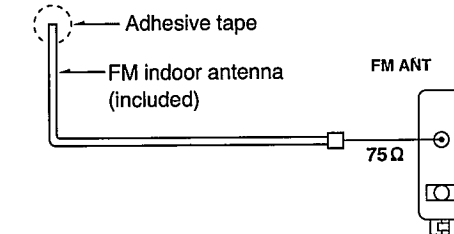

The tip of the internal antenna wire should not come into contact with any metal objects.
When you cannot get a good reception with this FM indoor antenna, we recommend you install an FM outdoor antenna (not included). Disconnect the FM indoor antenna if you install an FM outdoor antenna.

4 Connect the speaker cables.

Connection of speaker cables

1. Strip off the outer covering, and twist the center conductor.

Make sure the bare ends of the wires are not unraveled. (If they are, twist them tight again.)

2. Insert the wire to the rear panel of the speakers, and then pull down the lever.

3. Insert the wire to the rear panel of the tuner amplifier, and close the lever.

Notes:

- To prevent damage to circuitry, never short-circuit positive (+) and negative (-) speaker wires.
- Be sure to connect only positive (red) wires to positive (+) terminals and negative (black) wires to negative (-) terminals.

Note:

- Be sure to connect speaker cables before connecting the AC power supply cord.

5 Connect the surround speaker cord.

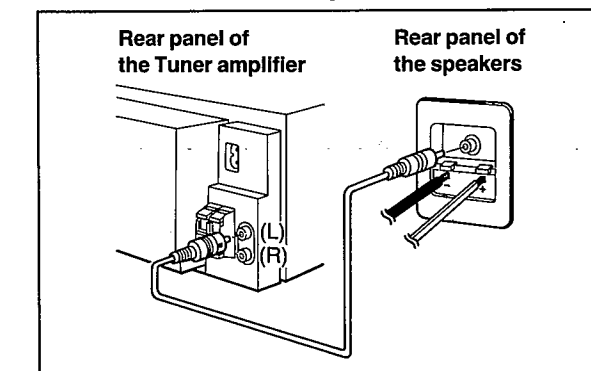

6 Connect the AC power supply cord after you have connected all other cables and cords.

Insertion of Connector

Even when the connector is perfectly inserted, depending on the type of inlet used, the front part of the connector may jut out as shown in the drawing. However there is no problem using the unit.

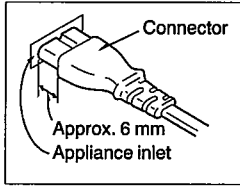

External unit connection

Television

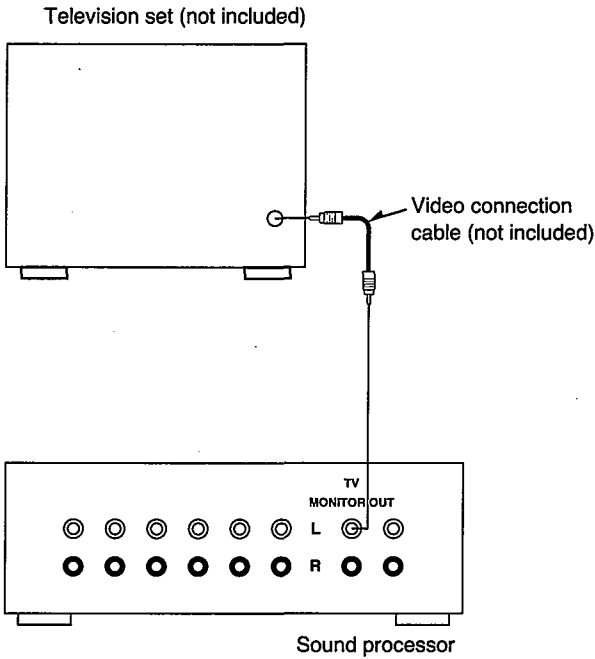

Video deck

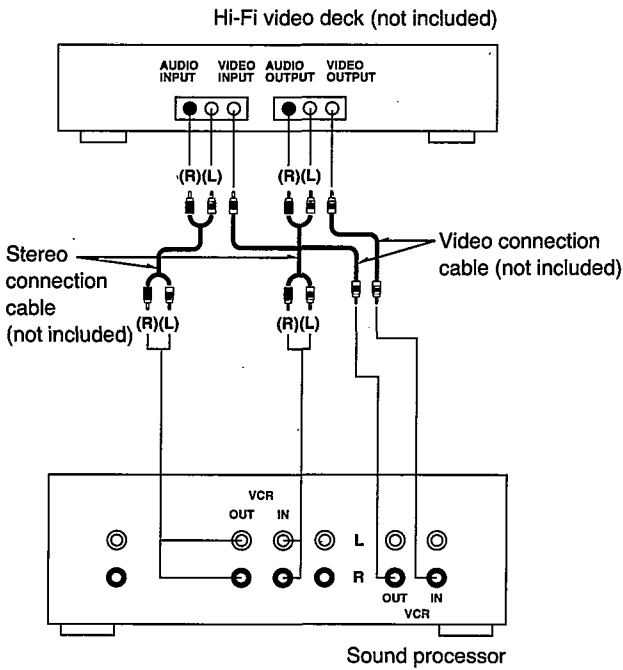

When you use a monaural video deck, connect it with monaural video connection cable.

DAT (digital audio tape deck)

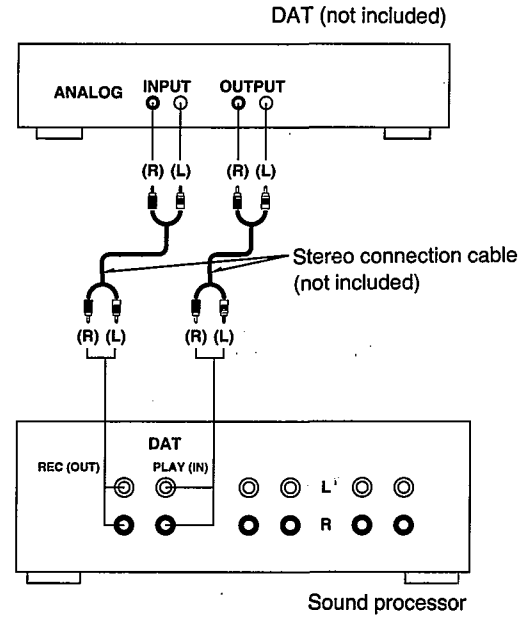

Analog player

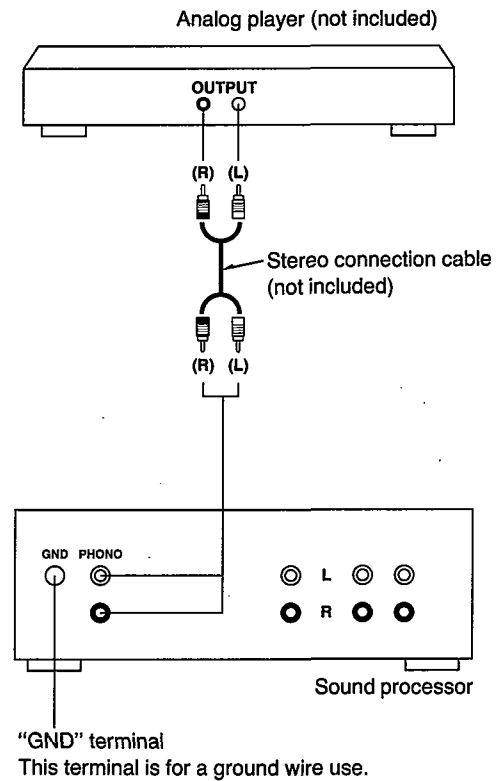

Center speaker

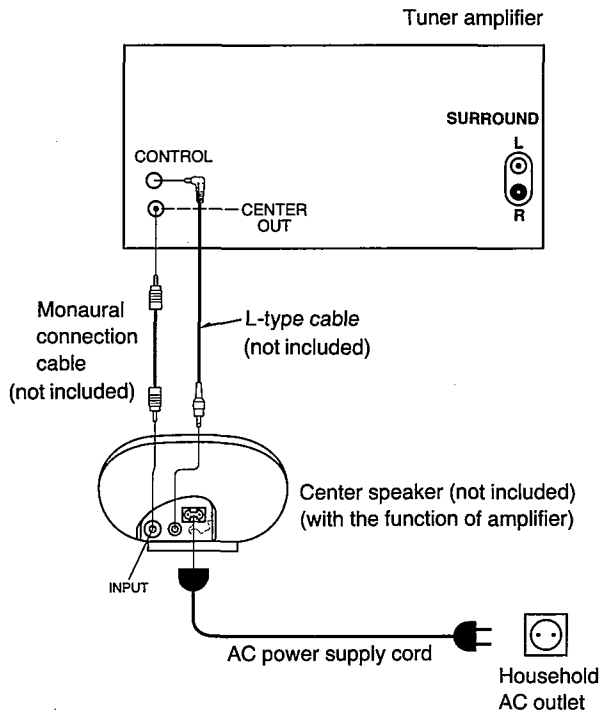

Note:
When you use a center speaker which has not a built-in amplifier, connect it to an another amplifier.

Surround speaker

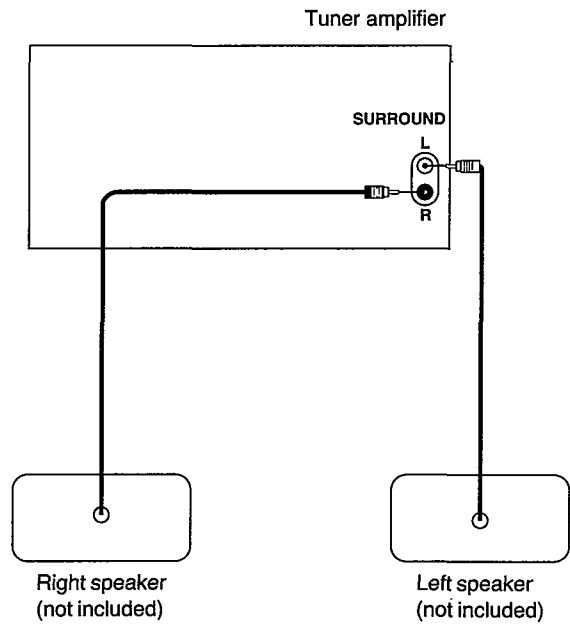

Notes:
Install each speaker left and right at the back of the listening space. Disconnect the surround speaker cords provided for model SC-CH950 (see step 5 on page 6) when connecting the optional surround speaker system.

Video disc player

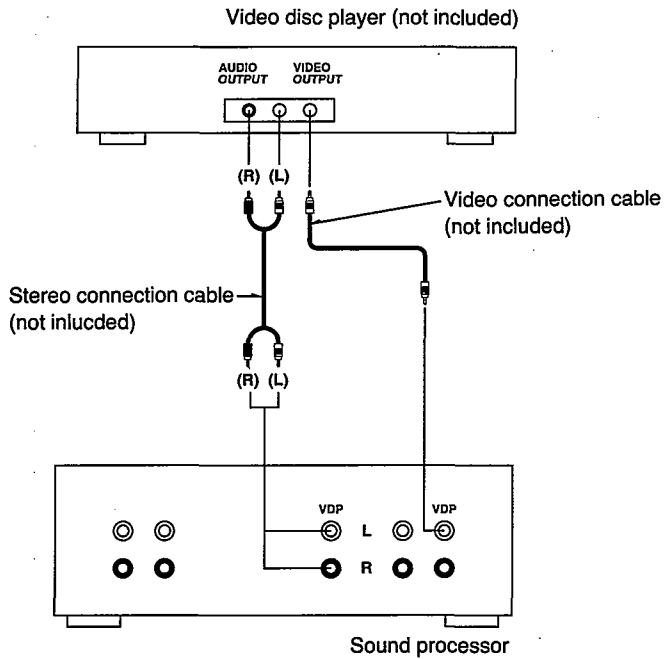

■ SETTING THE TIME OF DAY

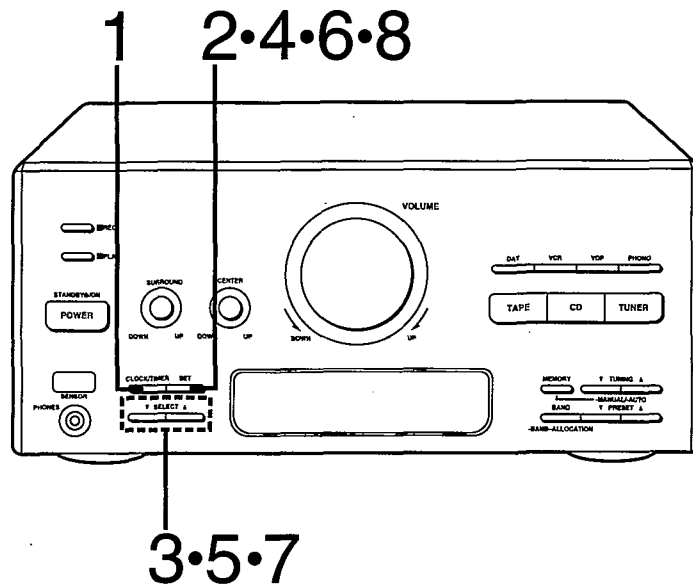
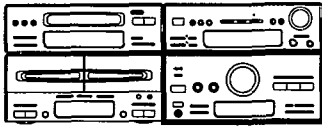

These instructions explain how to set the time for 16:25 (4:25 p.m.) on Wednesday.

Switch on the power.

1 Press **CLOCK/TIMER** to select "CLOCK".

The display will show **CLOCK**.

The display will return to what was previously indicated if you allow 7 or more seconds to elapse before you accomplish the next operation.

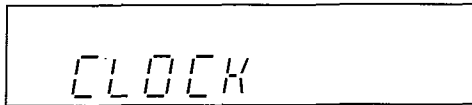

2 Press **SET**.

The day indicator will start to flash.

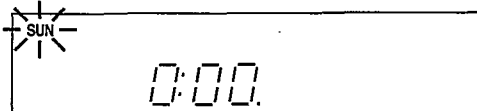

3 Press one of the **SELECT** buttons to select "WED".

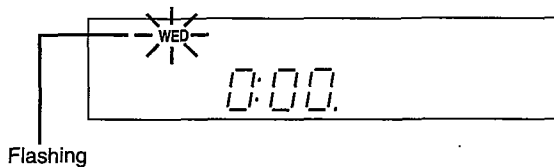

4 Press **SET**.

5 Press one of the **SELECT** buttons to select "16".

Going from 23:59 to 00:00 on the hour display will not change the day display.

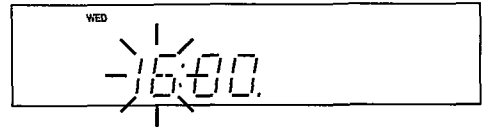

6 Press **SET**.

7 Press one of the **SELECT** buttons to select "25".

Going from 59 to 00 on the minute display will not change the hour display.

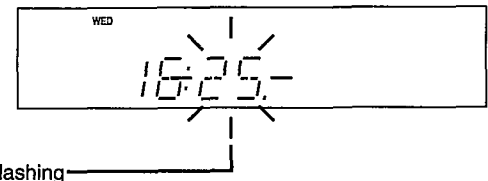

8 Press **SET** to finish setting the time.

After about 2 seconds, the display will return to what it were before entering the clock setting mode.

To display the clock again, press **CLOCK/TIMER**. The display will show "CLOCK", and then clock will appear for 5 seconds.

"E" appears on the display if the power cord has been once disconnected or there has been a power failure. If this happens, reset the time.

DISASSEMBLY INSTRUCTIONS

"ATTENTION SERVICER"

Some chassis components may have sharp edges. Be careful when disassembling and servicing.

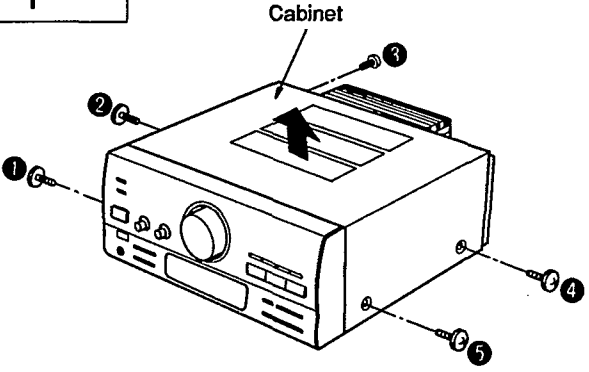
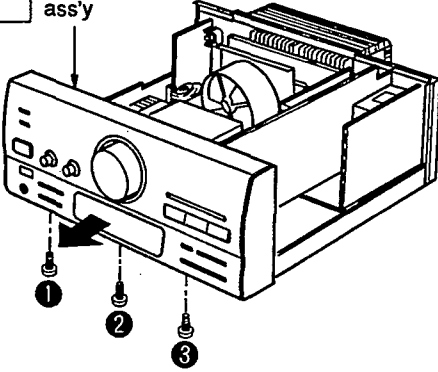
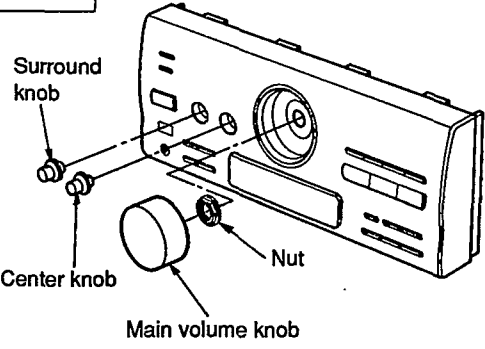
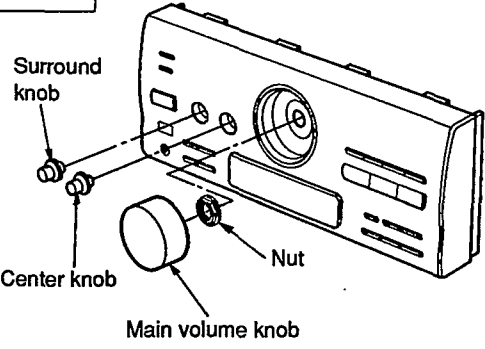
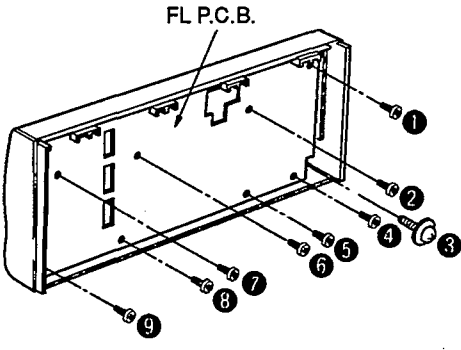
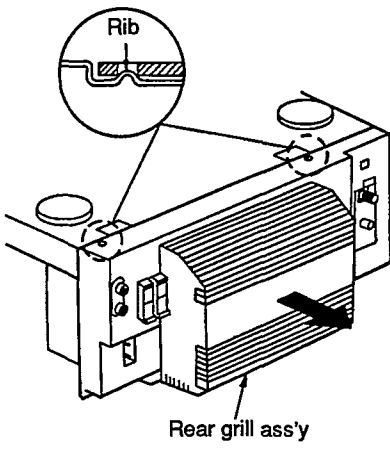
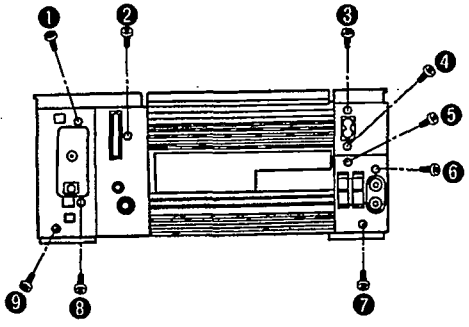
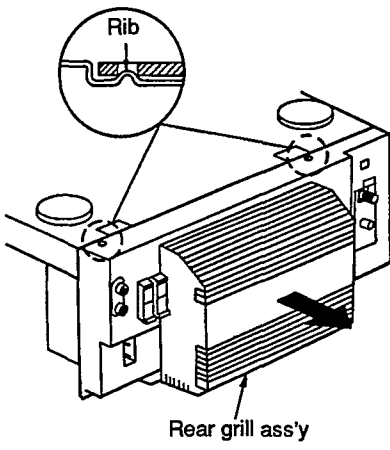
Ref. No. 1	Removal of the Cabinet	Ref. No. 2	Removal of the Front Panel Ass'y
Procedure 1	 <p>1. Remove the 5 screws (1~5).</p> <p>2. Remove the cabinet in the direction of arrow.</p>	Procedure 1→2	 <p>1. Remove the 3 screws (1~3).</p> <p>2. Remove the front panel ass'y in the direction of arrow.</p>
Ref. No. 3	Removal of the FL P.C.B.	 <p>1. Pull out the main volume knob.</p> <p>2. Remove the nut.</p> <p>3. Pull out the surround knob and center knob.</p>	
Procedure 1→2→3	 <p>1. Pull out the main volume knob.</p> <p>2. Remove the nut.</p> <p>3. Pull out the surround knob and center knob.</p>	Ref. No. 4	 <p>4. Remove the 9 screws (1~9).</p>
Ref. No. 4	Removal of the Rear Grill Ass'y	 <p>2. Remove the 2 ribs.</p> <p>3. Remove the rear grill ass'y in the direction of arrow.</p>	
Procedure 1→4	 <p>1. Remove the 9 screws (1~9).</p>	 <p>2. Remove the 2 ribs.</p> <p>3. Remove the rear grill ass'y in the direction of arrow.</p>	

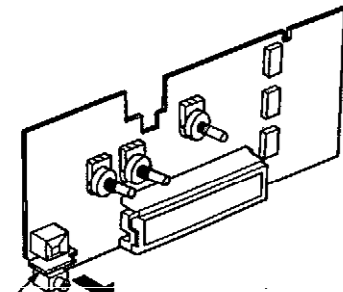
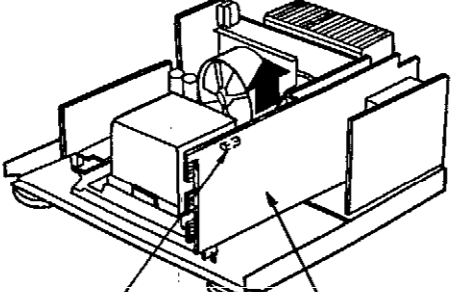
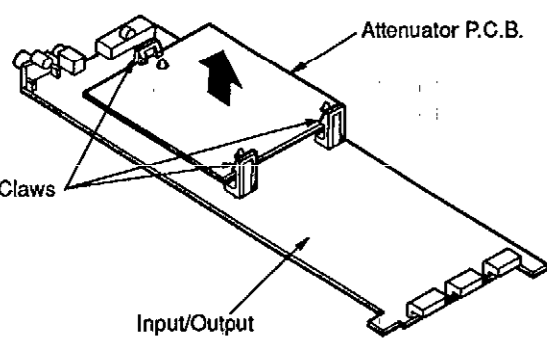
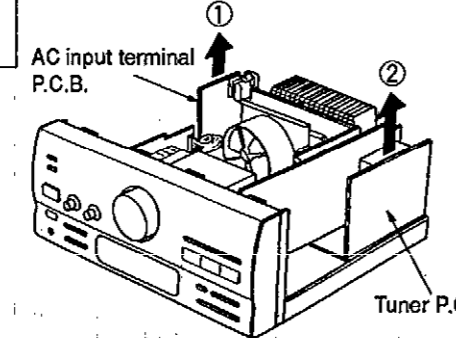
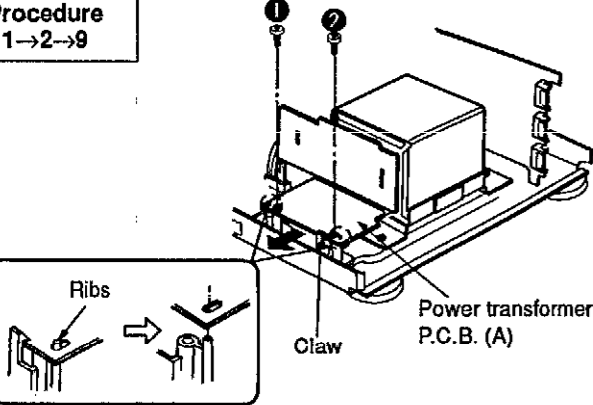
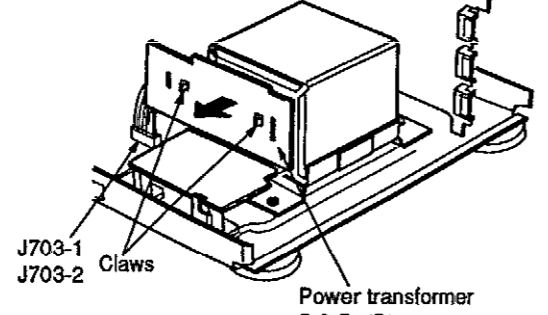
Ref. No. 5	Removal of the Headphones Jack P.C.B.	Procedure 1→2→3→5	Ref. No. 6	Removal of the Input/output Terminal P.C.B.	Procedure 1→2→4→6
 <p>Headphones jack P.C.B.</p> <p>Remove the headphones jack P.C.B. in the direction of arrow.</p>			 <p>JK351 Input/output terminal P.C.B.</p> <ol style="list-style-type: none"> 1. Remove the 1 connector (JK351). 2. Remove the input/output terminal P.C.B. in the direction of arrow. 		
Ref. No. 7	Removal of the Attenuator P.C.B.	Procedure 1→2→4→6→7	Ref. No. 8	Removal of the AC Input Terminal P.C.B. and Tuner P.C.B.	Procedure 1→4→8
 <p>Attenuator P.C.B.</p> <p>Claws</p> <p>Input/Output terminal P.C.B.</p> <p>Release the 3 claws.</p>			 <p>AC input terminal P.C.B.</p> <p>Tuner P.C.B.</p> <p>Removal of the AC Input Terminal P.C.B. Remove the AC input terminal P.C.B. in the direction of arrow ①.</p> <p>Removal of the Tuner P.C.B. Remove the tuner P.C.B. in the direction of arrow ②.</p>		
Ref. No. 9	Removal of the Power Transformer P.C.B. (A)	Procedure 1→2→9	Ref. No. 10	Removal of the Power Transformer P.C.B. (B)	Procedure 1→2→10
 <p>Ribs</p> <p>Claw</p> <p>Power transformer P.C.B. (A)</p> <ol style="list-style-type: none"> 1. Remove the 2 screws (①, ②). 2. Release the 1 claw. 3. Remove the 2 rib. 4. Remove the power transformer P.C.B. (A) in the direction of arrow. 			 <p>J703-1 J703-2 Claws</p> <p>Power transformer P.C.B. (B)</p> <ol style="list-style-type: none"> 1. Remove the 2 connector (J703-1, J703-2). 2. Release the 2 claws. 3. Remove the power transformer P.C.B. (B) in the direction of arrow. 		

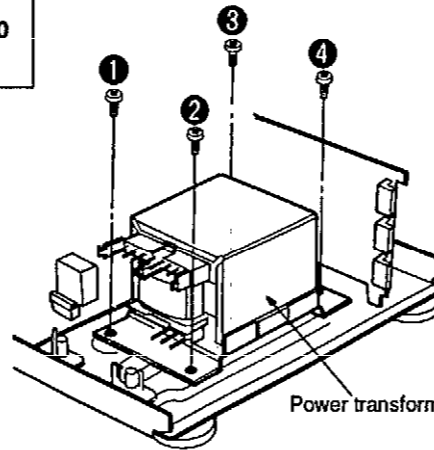
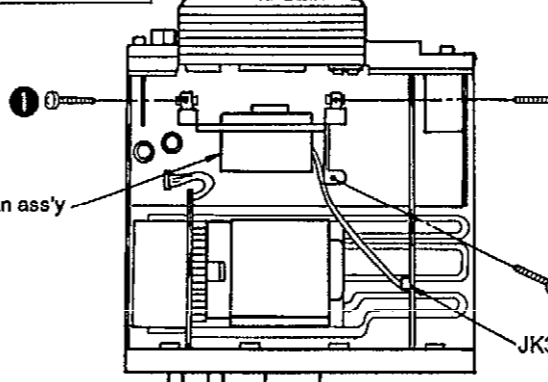
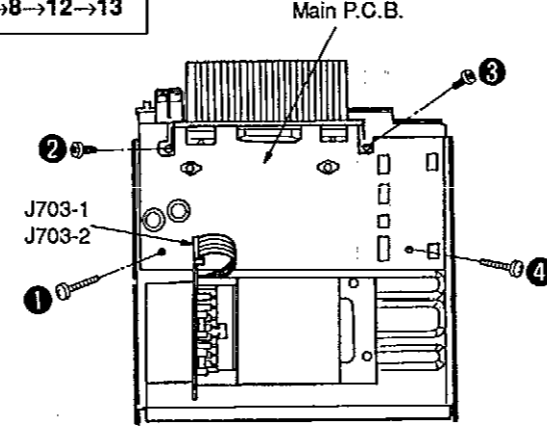
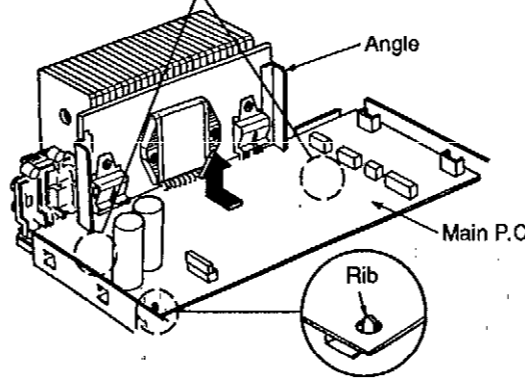
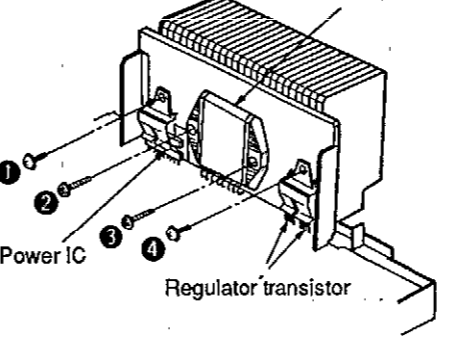
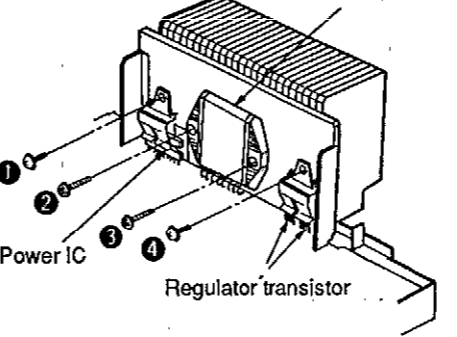
Ref. No. 11	Removal of the Power Transformer	Procedure 1→2→9→10→11	Ref. No. 12	Removal of the Fan Ass'y	Procedure 1→12
 <p>Power transformer</p> <p>Remove the 4 screws (①-④).</p>			 <p>Fan ass'y</p> <p>JK351</p> <ol style="list-style-type: none"> 1. Remove the 1 connector (JK351). 2. Remove the 3 screws (①-③). 		
Ref. No. 13	Removal of the Main P.C.B.	Procedure 1→2→4→6→8→12→13	<p>NOTE Insert the projection on the angle into the hole of the bottom board ass'y and then install the Main P.C.B.</p> <p>[Bottom view] Projection</p>		
 <p>Main P.C.B.</p> <p>J703-1 J703-2</p> <ol style="list-style-type: none"> 1. Remove the 4 screws (①-④). 2. Remove the 2 connector (J703-1, J703-2). 			 <p>Angle</p> <p>Main P.C.B.</p> <p>Rib</p> <ol style="list-style-type: none"> 3. Remove the rib. 4. Remove the main P.C.B. in the direction of arrow. 		
Ref. No. 14	Removal of the Power IC and Regulator Transistor	Procedure 1→2→4→6→8→12→13→14	<p>1. Unsolder the power IC or regulator transistors.</p> <p>2. Remove the 4 screws (①-④).</p> <p>When mounting the power IC or regulator transistor, apply silicone compound (RFKX0002) to the rear side of power IC or regulator transistors.</p>		
 <p>Power IC</p> <p>Regulator transistor</p>					

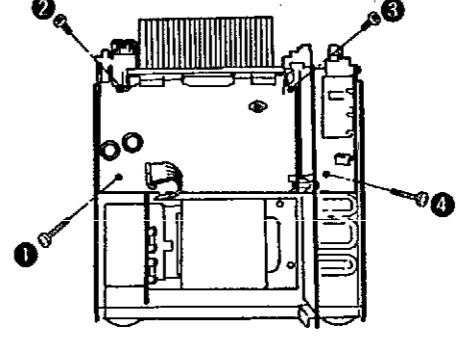
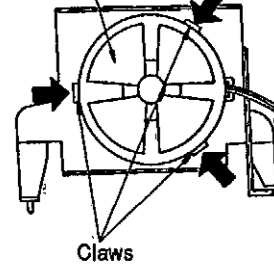
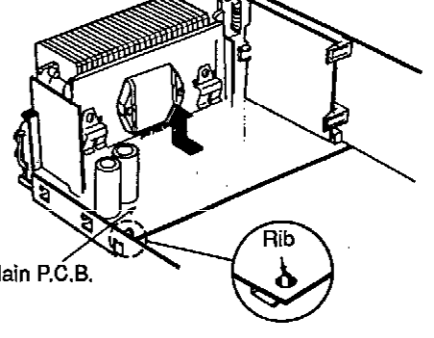
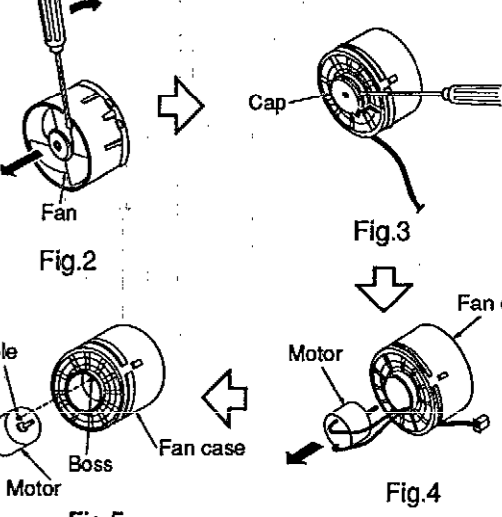
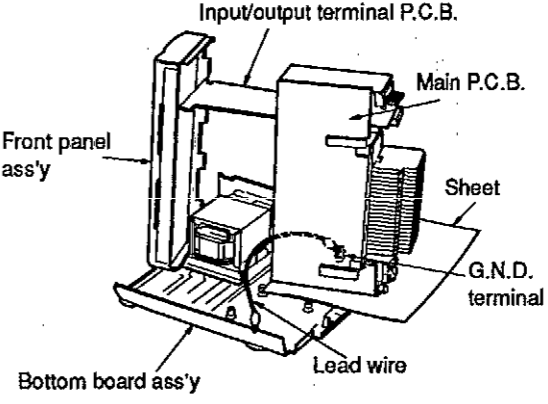
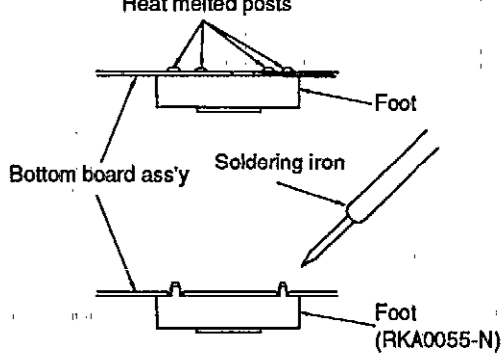
Ref. No. 15	How to check the Main P.C.B.	Procedure 1→2→4→12→15	Ref. No. 16	Removal of the Fan Ass'y	Procedure 1→12→16
<p>When checking the soldered surfaces of main P.C.B. and replacing the parts, do as show.</p>  <ol style="list-style-type: none"> 1. Remove the 4 screws (①-④). 			 <p>Fan ass'y</p> <p>Claws</p> <p>Fig.1</p> <ol style="list-style-type: none"> 1. Release the 3 claws (shown in Fig.1). 		
 <p>Main P.C.B.</p> <p>Rib</p> <ol style="list-style-type: none"> 2. Remove the rib. 3. Remove the main P.C.B. in the direction of arrow. 			 <p>Cap</p> <p>Fan</p> <p>Fig.2</p> <p>Fig.3</p> <p>Hole</p> <p>Motor</p> <p>Boss</p> <p>Fan case</p> <p>Fig.4</p> <p>Fig.5</p> <ol style="list-style-type: none"> 2. Insert a screwdriver at the root of the fan (shown in Fig. 2). 3. Remove the cap (shown in Fig.3). 4. Remove the motor from the fan case (shown in Fig.4). 5. When mounting the motor, align the fan case projection with the hole of the motor (shown in Fig.5). 		
 <p>Input/output terminal P.C.B.</p> <p>Main P.C.B.</p> <p>Front panel ass'y</p> <p>Sheet</p> <p>Bottom board ass'y</p> <p>Lead wire</p> <p>G.N.D. terminal</p> <ol style="list-style-type: none"> 4. Connect the G.N.D. terminal of the bottom board ass'y by the lead wire. 5. Reinstall the front panel ass'y to the input/output terminal P.C.B. 			<p>Replacement of the Foot</p> <ol style="list-style-type: none"> 1. Remove the 4 heat melted posts on the Bottom board ass'y with a pair of nippers or similar tool. 2. To replace the foot (RKA0055-N) on the Bottom board ass'y melt the 4 posts with a soldering iron.  <p>Heat melted posts</p> <p>Foot</p> <p>Bottom board ass'y</p> <p>Soldering iron</p> <p>Foot (RKA0055-N)</p>		

SCHEMATIC DIAGRAM • FL/HEADPHONES JACK CIRCUIT (Parts list on pages 35~39)

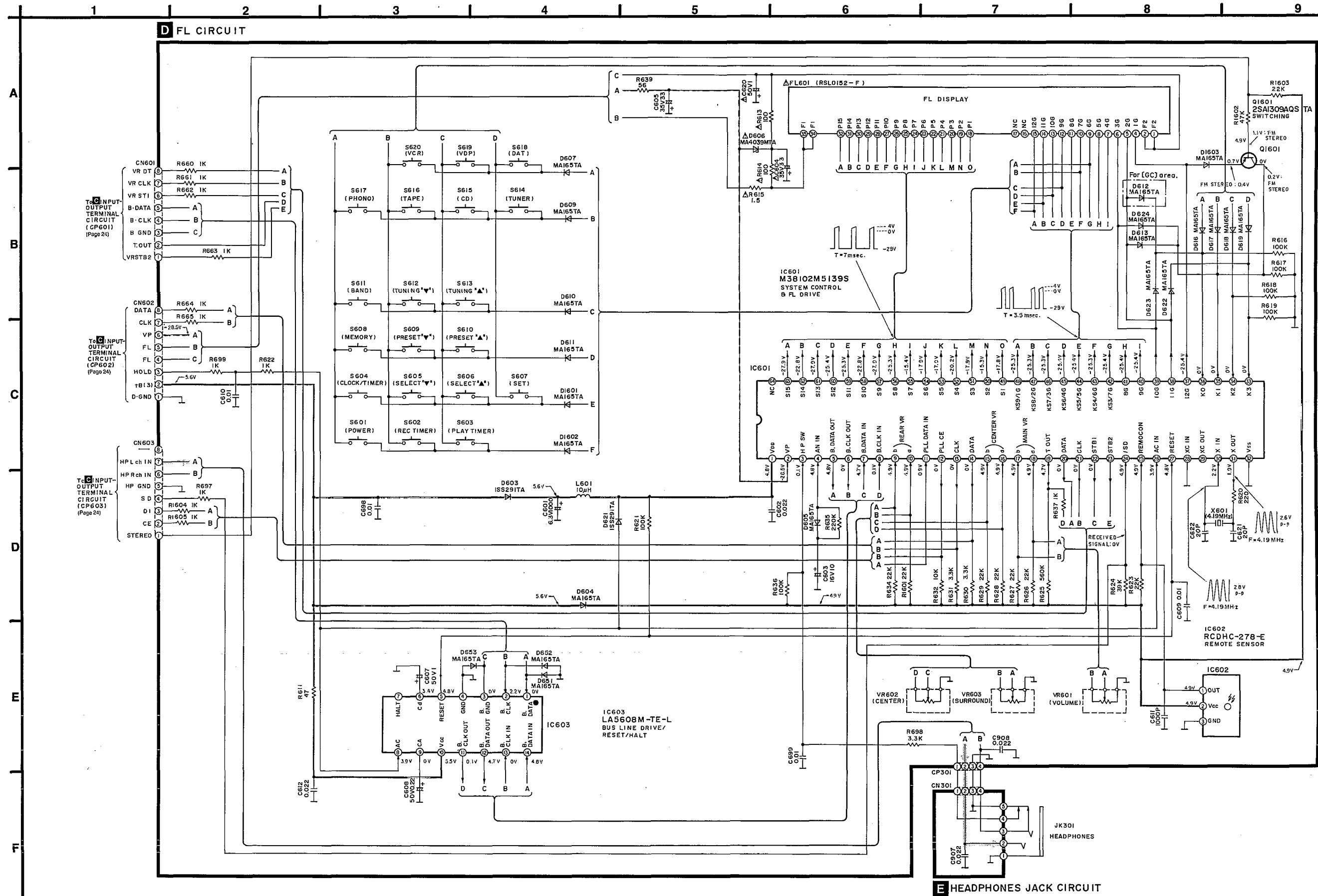

■ SCHEMATIC DIAGRAM • MAIN/POWER TRANSFORMER (A)/(B)/AC IN TERMINAL CIRCUIT (Parts list on pages 35-39)

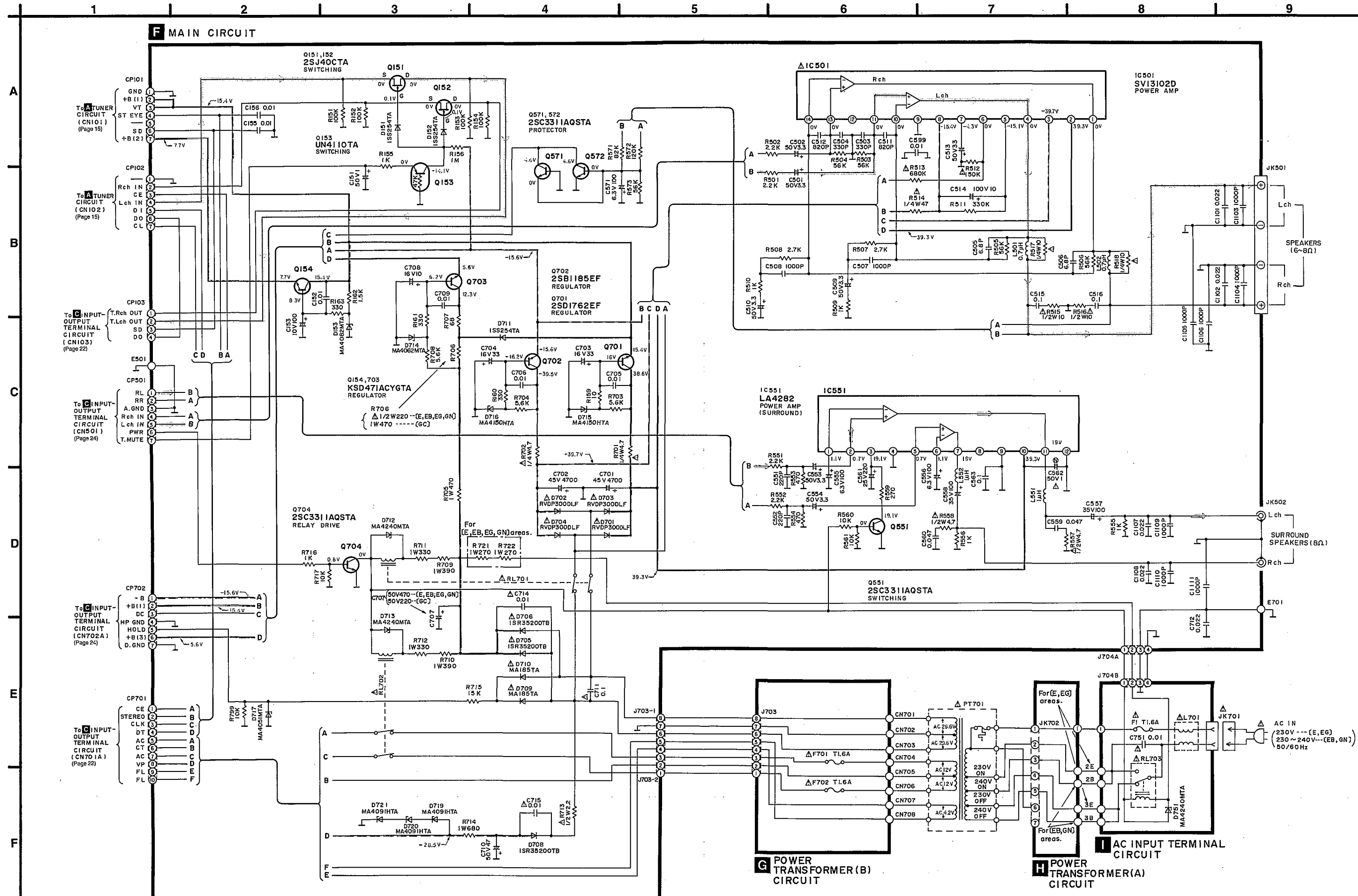

SCHEMATIC DIAGRAM ATTENUATOR/INPUT/OUTPUT TERMINAL CIRCUIT (Parts list on pages 35-39)

B ATTENUATOR CIRCUIT

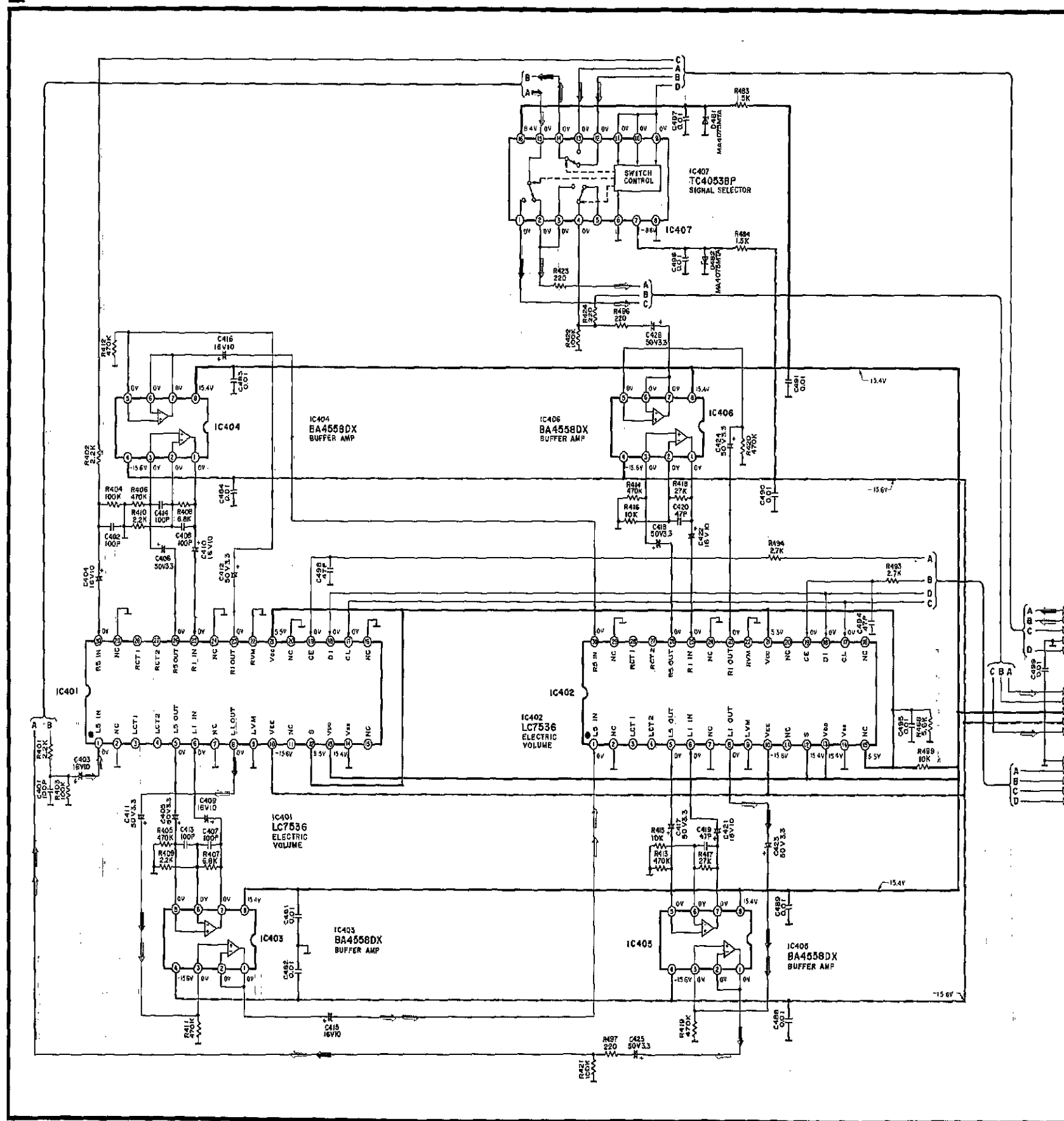

C INPUT-OUTPUT TERMINAL CIRCUIT

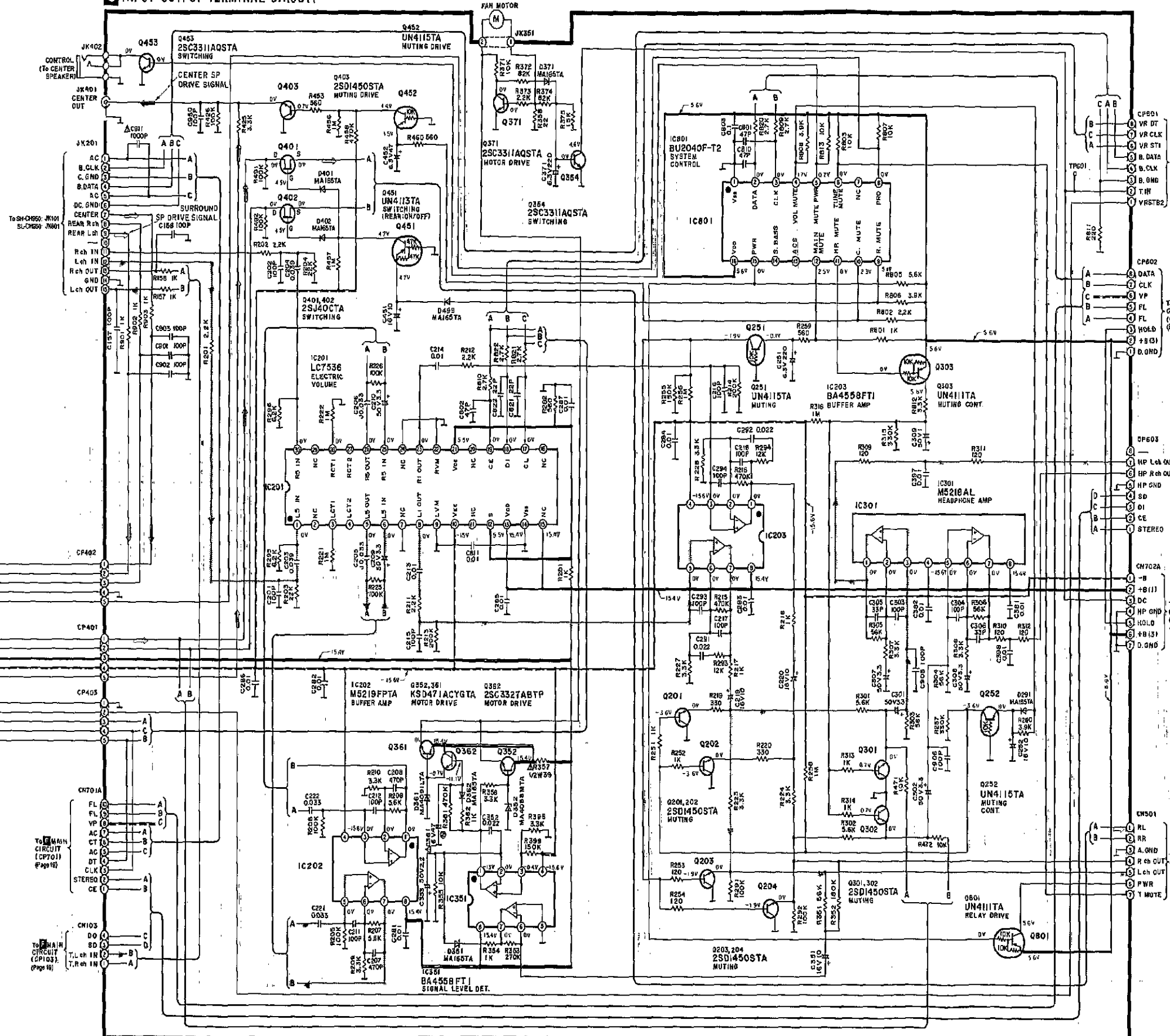

- Notes:
- S701: Voltage selector switch in "220 V" position (110 V/127 V/220 V/240 V) <for (GC) area only>
 - Indicated voltage values are the standard values for the unit measured by the DC electronic circuit tester (high-impedance) with the chassis taken as standard. Therefore, there may exist some errors in the voltage values, depending on the internal impedance of the DC circuit tester. No mark: FM mode
 - Important safety notice: Components identified by Δ mark have special characteristics important for safety. Furthermore, special parts which have purposes of fire-retardant (resistors), high-quality sound (capacitors), low-noise (resistors), etc. are used. When replacing any of components, be sure to use only manufacturer's specified parts shown in the parts list.
 - This schematic diagram may be modified at any time with the development of new technology.

•Caution!
IC and LSI are sensitive to static electricity. Secondary trouble can be prevented by taking care during repair. Ground the soldering iron. Put a conductive mat on the work table. Do not touch the legs of IC of LSI with the fingers directly.

- : Positive voltage line
- - - : Negative voltage line
- ⊘ : AF signal line
- ➡ : Surround SP. drive signal line
- ➡ : Center SP. drive signal line

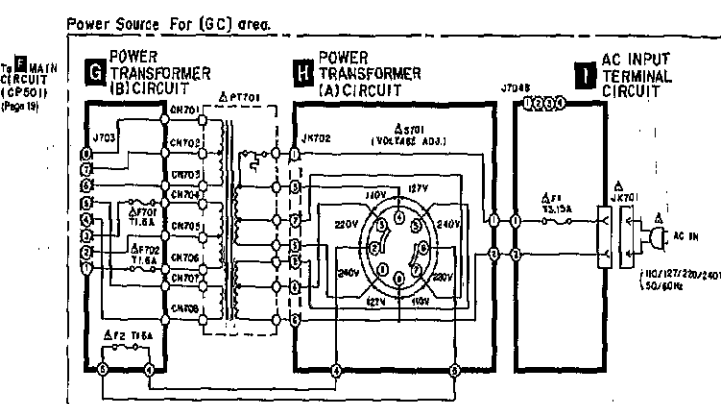

PRINTED CIRCUIT BOARD DIAGRAM

A TUNER P.C.B. (REP1452C-T... (EG)
REP1452D-T... (E,EB)
REP1452E-T... (GC,GN))

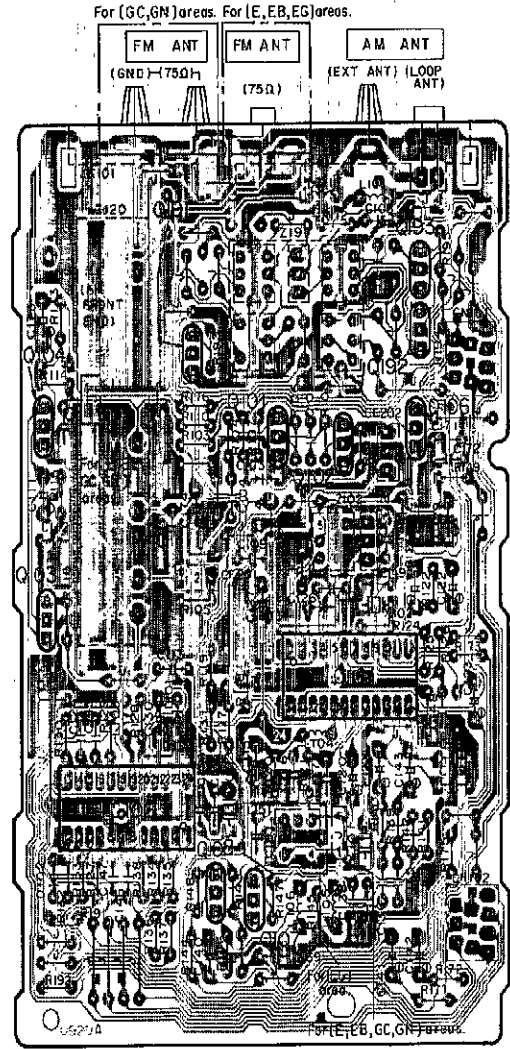

Note: This circuit board diagram may be modified at any time with the development of new technology.

D FL P.C.B. (REP1481E-S... (GC)
REP1481F-S... (E,EB,EG,GN))

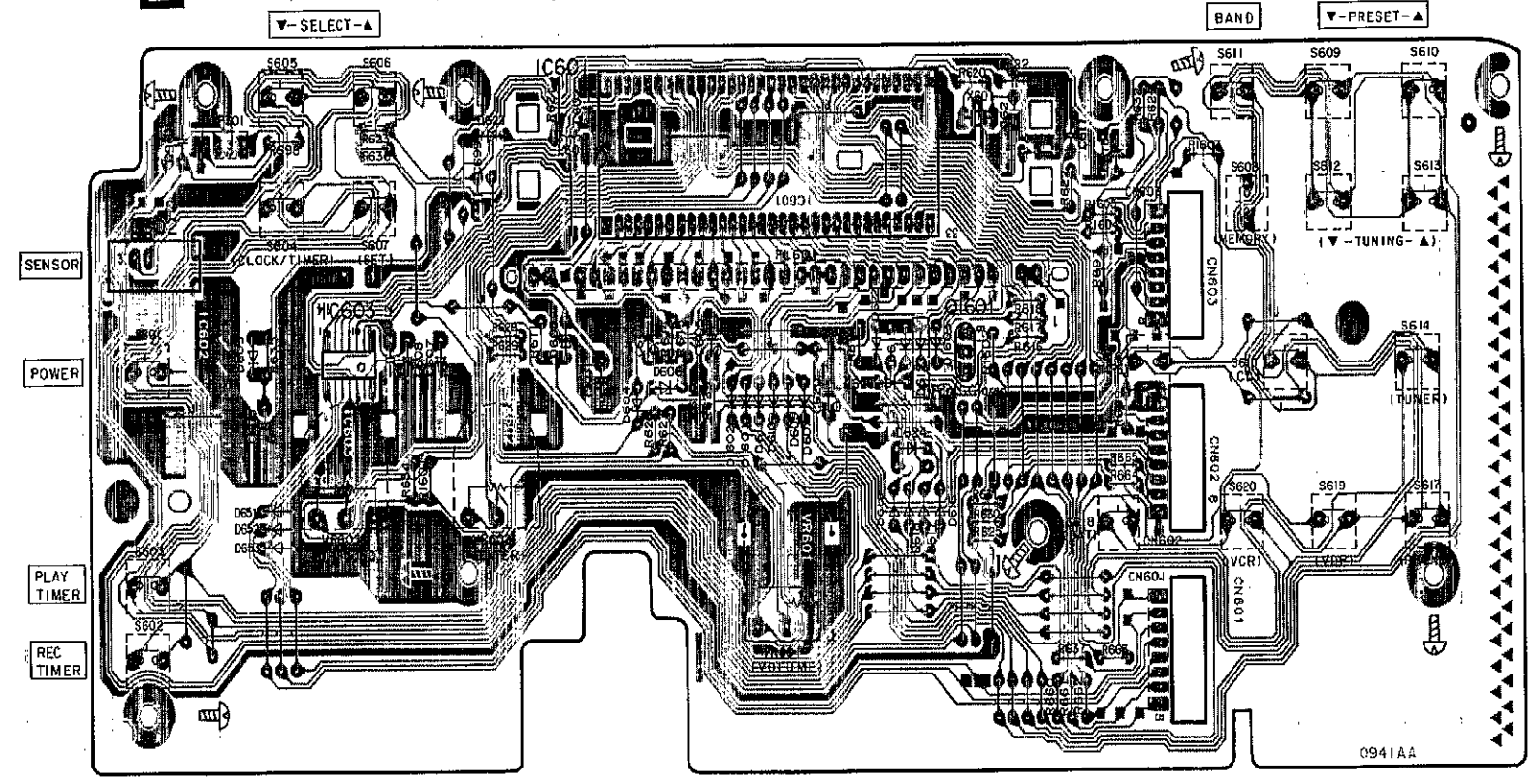

*Terminal guide of IC's, transistors and diodes

BA4568FT1	M5219FFTA LA5608M-TE-L BU2040F-T2	8 Pin 14 Pin 16 Pin	TC4053BP	LA1830-H LC7218	LC7536	BA4558DX M38102M5139S	8 Pin 64 Pin	M5218AL	SV13102D	LA4282	PCDHC-278-E
	UN4110TA UN4111TA UN4113TA UN4115TA		2SB1185EF 2SD1762EF	KSD471ACYGTA	2SJ40CTA	RVDP300DLF					
	MA165TA MA185TA 1SS254TA 1SR3520TB		1SS291TA	MA4150LTA MA4240MTA							
					MA4051MTA MA4062MTA MA4075MTA MA4082MTA MA4091HTA MA4068MTA MA4091LTA						

B ATTENUATOR P.C.B. (REP1478A-T)

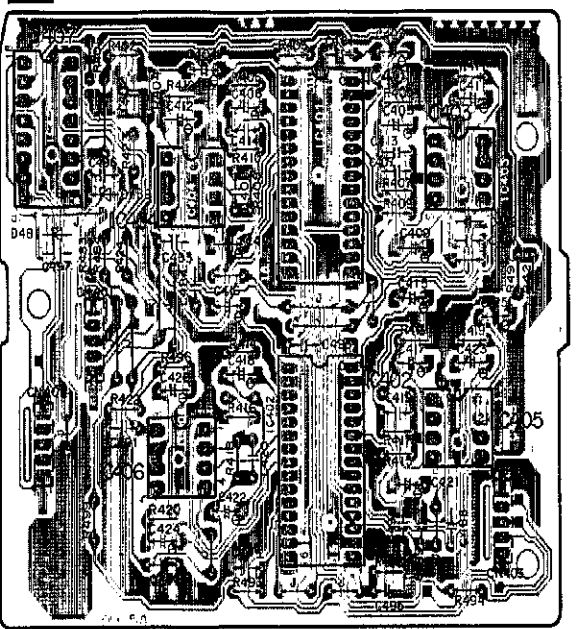

C INPUT-OUTPUT TERMINAL P.C.B. (REP1482B-T)

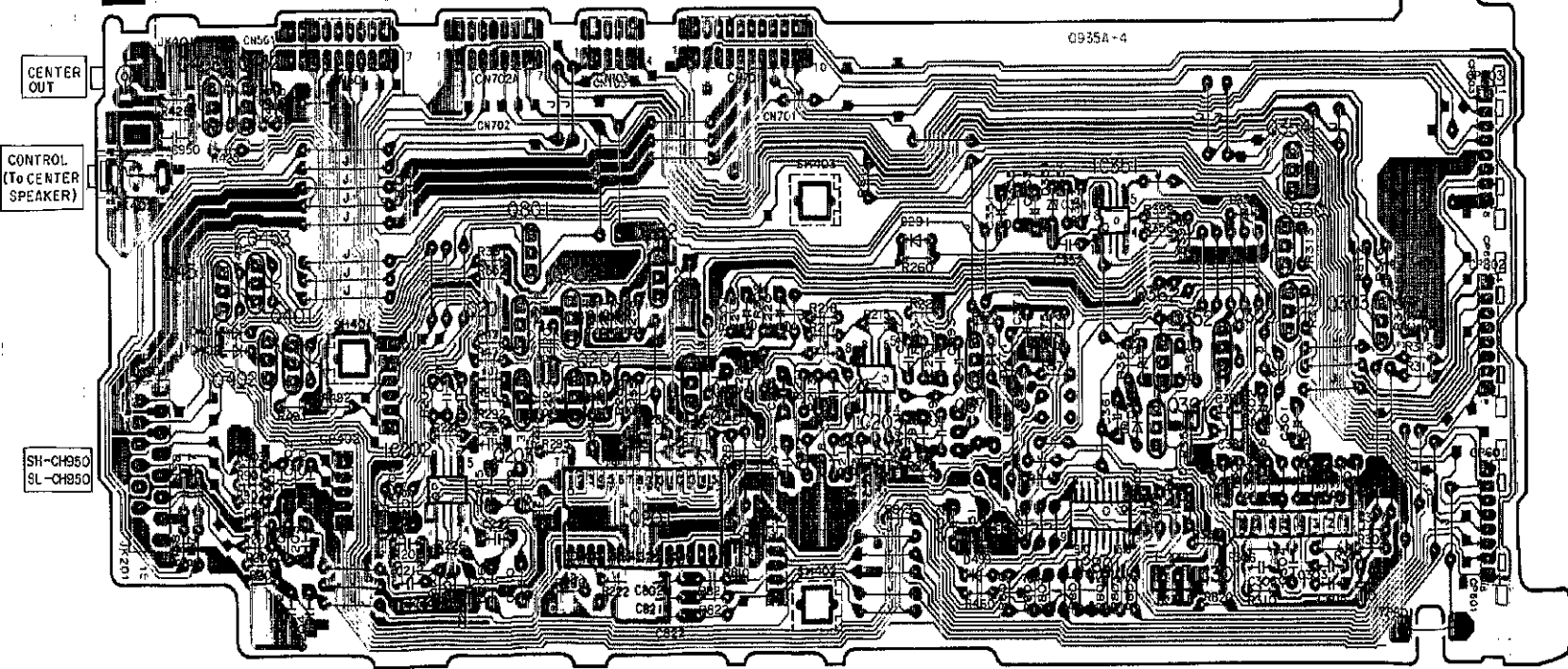

F MAIN P.C.B. (REP1480B-M... (GC)
REP1480C-M... (E,EB,EG,GN))

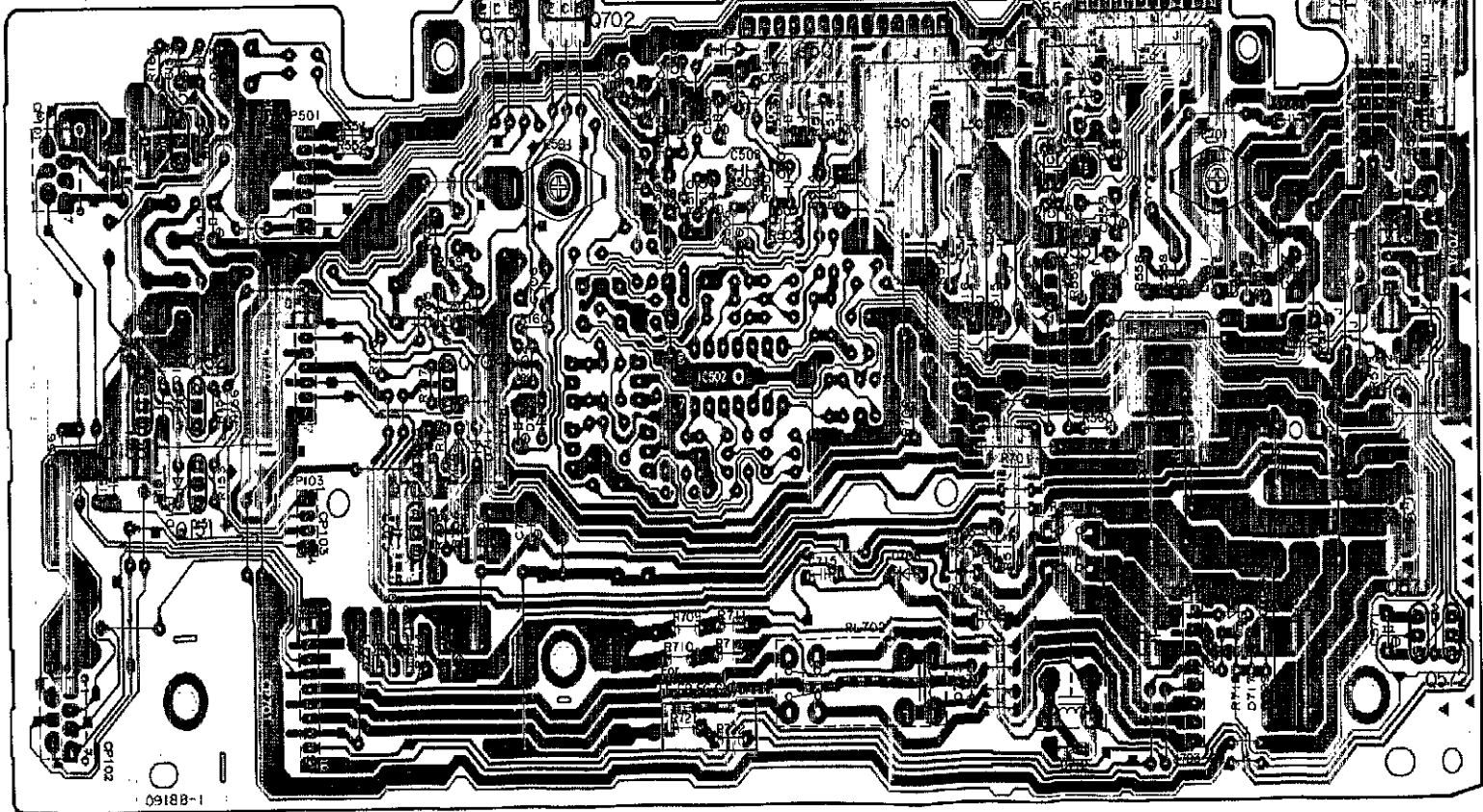

G POWER TRANSFORMER(B) P.C.B. (REP1483C-P... (GN)
REP1483D-P... (EB)
REP1483E-P... (E,EG))

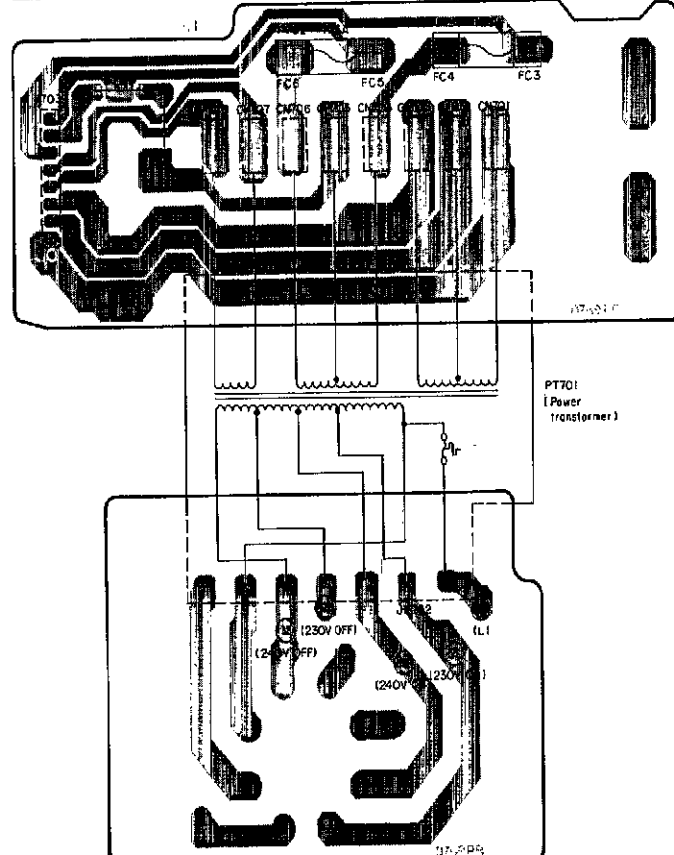

H POWER TRANSFORMER(A) P.C.B. (REP1483C-P... (GN)
REP1483D-P... (EB)
REP1483E-P... (E,EG))

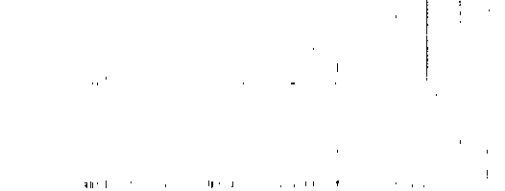

■ WIRING CONNECTION DIAGRAM

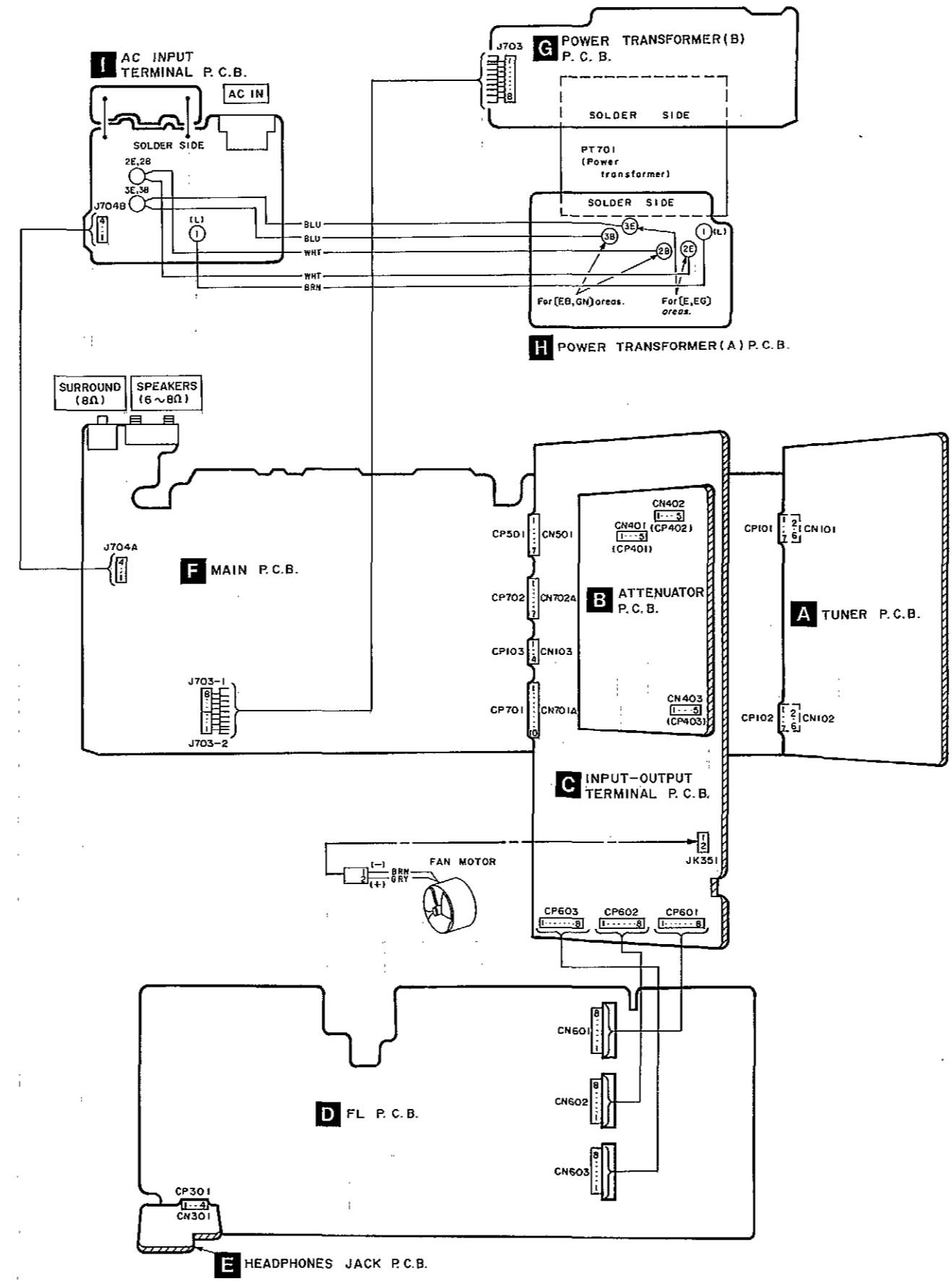
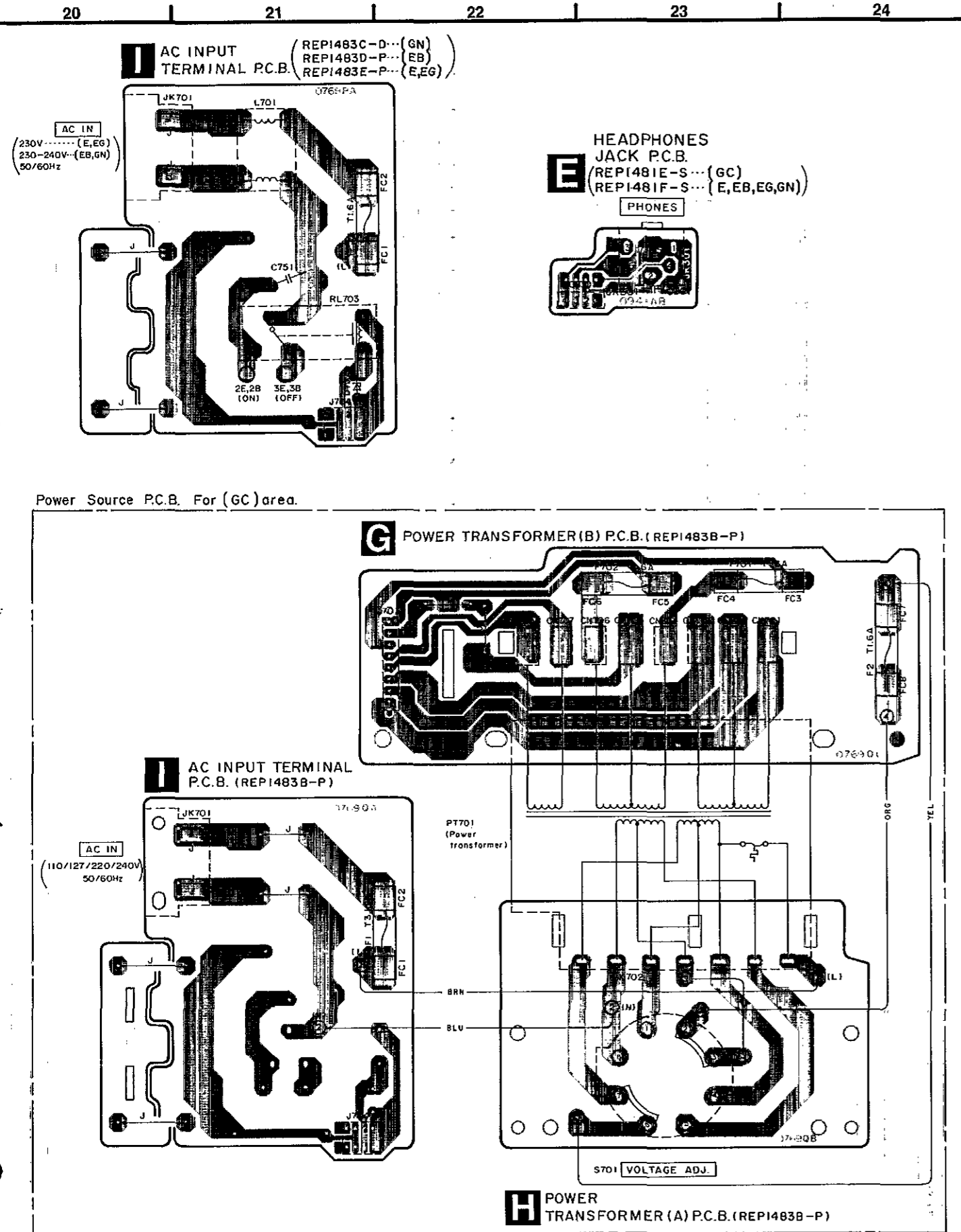

■ FUNCTION OF IC TERMINALS

●IC601 (M38102M5139S)

Pin No.	Terminal Name	I/O	Function
1	V _{DD}	—	Power supply (+5 V)
2	VP	—	Pull-down voltage
3	HP SW	I	Headphones switch
4	AN IN	I	CR timer during backup
5	B.DATA OUT	O	Bus data output
6	B.CLK OUT	O	Bus clock output
7	B.DATA IN	I	Bus data input
8	B.CLK IN	I	Bus clock input
9	REAR VR. b	I	Rotary encoder input (for REAR)
10	REAR VR. a	I	Rotary encoder input (for REAR)
11	PLL DATA IN	I	Serial data input for PLL tuner
12	PLL CE	O	Serial chip enable output for PLL tuner
13	CLK	O	Clock for M50253
14	DATA	O	Clock for M50253
15	CENTER VR. b	I	Rotary encoder input (for CENTER)
16	CENTER VR. a	I	Rotary encoder input (for CENTER)
17	MAIN VR. b	I	Rotary encoder input (for MAIN)
18	MAIN VR. a	I	Rotary encoder input (for MAIN)
19	T OUT	I/O	I: Starting clock adjustment O: 131.072 kHz (POWER OFF) Malfunction detection (POWER ON)
20	DATA	O	Data output for LC7536 & PLL tuner
21	CLK	O	Clock output for LC7536 & PLL tuner
22	STB1	O	Strobing for LC7536 (switched)

Pin No.	Terminal Name	I/O	Function
23	STB2	—	No use
24	/SD	I	Tuner/SD input
25	REMOCON	I	Remote control input
26	AC IN	I	Power down input
27	RESET	I	No use
28	XC IN	—	No use
29	XC OUT	—	No use
30	X IN	I	4.194304 oscillator
31	X OUT	O	
32	V _{SS}	—	Power supply (GND)
33	K3	I	Key input
34	K2	I	Key input
35	K1	I	Key input
36	K0	I	Key input
37	12G	O	Digit 12 & key scan (lock switch)
38	11G	O	Digit 11 (No use) & RESET
39	10G	O	Digit 10 (No use) & RESET
40	9G	O	Digit 9
41	8G	O	Digit 8
42	KS3/7G	O	Digit 7 & key scan
43	KS4/6G	O	Digit 6 & key scan
44	KS5/5G	O	Digit 5 & key scan
45	KS6/4G	O	Digit 4 & key scan
46	KS7/3G	O	Digit 3 & key scan
47	KS8/2G	O	Digit 2 & key scan
48	KS9/1G	O	Digit 1 & key scan
49	S1	O	Segment output
63	S15	O	Segment output
64	NC	—	No use

■ BLOCK DIAGRAM

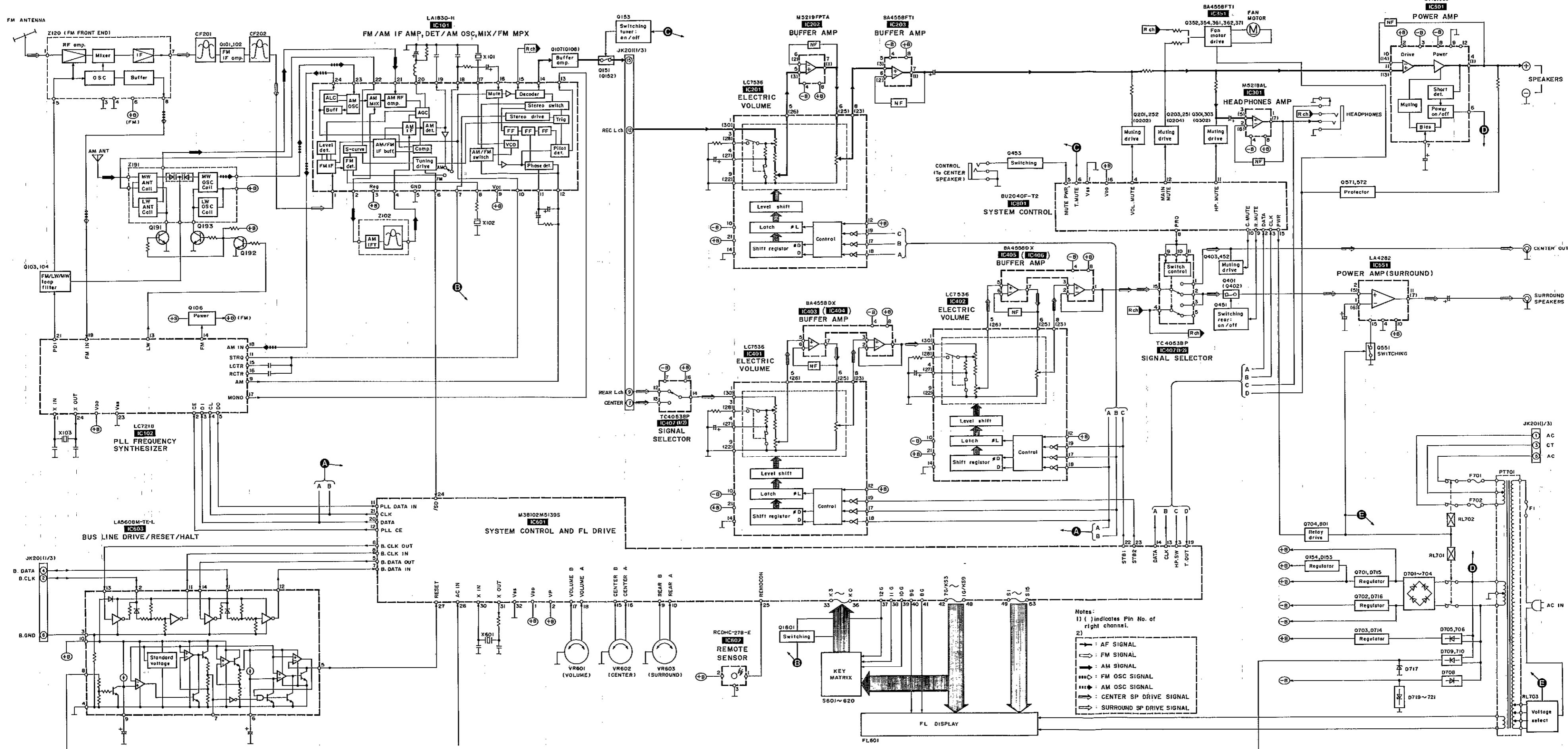

REPLACEMENT PARTS LIST

Notes: *Important safety notice:
 Components identified by Δ mark have special characteristics important for safety.
 Furthermore, special parts which have purposes of fire-retardant (resistors), high-quality sound (capacitors), low-noise (resistors), etc. are used.
 When replacing any of components, be sure to use only manufacturer's specified parts shown in the parts list.
 *The parenthesized indications in the Remarks columns specify the areas. (Refer to the cover page for area.)
 Parts without these indications can be used for all areas.
 *Remote Control Ass'y:
 Supply period for three years from termination of production.

Ref. No.	Part No.	Part Name & Description	Remarks	Ref. No.	Part No.	Part Name & Description	Remarks
		INTEGRATED CIRCUIT(S)					
IC101	LA1830-H	I. C. FM/AM IF AMP. /AM OSC		Q701	2SD1762EF	TRANSISTOR	
IC102	LC7218	I. C. PLL FREQ. SYNTHESIZER		Q702	2SB1185EF	TRANSISTOR	
IC201	LC7536	I. C. ELECTRIC VOLUME		Q703	KSD471ACYGTA	TRANSISTOR	
IC202	M5219FP	I. C. BUFFER AMP.		Q704	2SC3311A-Q	TRANSISTOR	
IC203	SV1BA4558F	I. C. BUFFER AMP.		Q801	UN4111	TRANSISTOR	
IC301	M5218L	I. C. HEADPHONE AMP.		Q1601	2SA1309A-R	TRANSISTOR	
IC351	SV1BA4558F	I. C. SIGNAL DET.				DIODE(S)	
IC401, 402	LC7536	I. C. ELECTRIC VOLUME		D101	MA4051MTA	DIODE	
IC403-406	BA4558DX	I. C. BUFFER AMP.		D102	MA165	DIODE	
IC407	TC4053BP	I. C. SIGNAL SELECTOR		D151, 152	1SS254TA	DIODE	
IC501	SV13102D	I. C. POWER AMP.	Δ	D153	MA4082MTA	DIODE	
IC551	LA4282	I. C. POWER AMP. (SURROUND)		D291	MA165	DIODE	
IC601	M38102M5139S	I. C. FL DRIVE/SYSTEM CONT.		D351	MA165	DIODE	
IC602	RCDHC-278	I. C. REMOTE SENSOR		D352	MA4068M	DIODE	
IC603	LA5608M-TE-L	I. C. BUS LINE/HALT/RESET		D361	MA4091LTA	DIODE	
IC801	BU2040F-T2	I. C. SYSTEM CONT.		D362	MA165	DIODE	
		TRANSISTOR(S)		D371	MA165	DIODE	
Q101, 102	2SC2787L	TRANSISTOR		D401, 402	MA165	DIODE	
Q103, 104	2SC2785FE	TRANSISTOR		D481, 482	MA4075MTA	DIODE	
Q106	UN411FTA	TRANSISTOR		D499	MA165	DIODE	
Q107, 108	2SC3311A-Q	TRANSISTOR		D603	1SS291TA	DIODE	
Q151, 152	2SJ40CTA	TRANSISTOR		D604, 605	MA165	DIODE	
Q153	UN4110TA	TRANSISTOR		D606	MA4039MTA	DIODE	Δ
Q154	KSD471ACYGTA	TRANSISTOR		D607	MA165	DIODE	
Q191-193	2SC3311A-Q	TRANSISTOR		D609-611	MA165	DIODE	
Q201-204	2SD1450RTA	TRANSISTOR		D612	MA165	DIODE	(GC)
Q251, 252	UN4115	TRANSISTOR		D613	MA165	DIODE	
Q301, 302	2SD1450RTA	TRANSISTOR		D616-619	MA165	DIODE	
Q303	UN4111	TRANSISTOR		D621	1SS291TA	DIODE	
Q352	KSD471ACYGTA	TRANSISTOR		D622-624	MA165	DIODE	
Q354	2SC3311A-Q	TRANSISTOR		D651-653	MA165	DIODE	
Q361	KSD471ACYGTA	TRANSISTOR		D701-704	RVDP300DLF	DIODE	Δ
Q362	2SC3327-A	TRANSISTOR		D705, 706	1SR35200TB	DIODE	Δ
Q371	2SC3311A-Q	TRANSISTOR		D708	1SR35200TB	DIODE	
Q401, 402	2SJ40CTA	TRANSISTOR		D709, 710	MA185TA	DIODE	Δ
Q403	2SD1450RTA	TRANSISTOR		D711	1SS254TA	DIODE	
Q451	UN4113TA	TRANSISTOR		D712, 713	MA4240H	DIODE	
Q452	UN4115	TRANSISTOR		D714	MA4062MTA	DIODE	
Q453	2SC3311A-Q	TRANSISTOR		D715, 716	MA4150M	DIODE	
Q551	2SC3311A-Q	TRANSISTOR		D717	MA4051MTA	DIODE	
Q571, 572	2SC3311A-Q	TRANSISTOR		D719-721	MA4091HTA	DIODE	
				D751	MA4240H	DIODE	(E, EB, EG, GN)
				D1601-1603	MA165	DIODE	

Ref. No.	Part No.	Part Name & Description	Remarks	Ref. No.	Part No.	Part Name & Description	Remarks
		VARIABLE RESISTOR(S)					
VR601	EVQWVF2024B	V. R. MAIN VOLUME CONT.		S601	EVQ21405R	SW, POWER	
VR602	EVQWQ2F1524B	V. R. CENTER VOLUME CONT.		S602	EVQ21405R	SW, TIMER REC	
VR603	EVQWQ2F1524B	V. R. SURROUND VOLUME CONT.		S603	EVQ21405R	SW, TIMER PLAY	
		COMPONENT COMBINATION(S)		S604	EVQ21405R	SW, CLOCK/TIMER	
Z102	RL12Z006M-T	COMPONENT COMBINATION		S605	EVQ21405R	SW, SELECT (DOWN)	
Z120	RAL0006	TUNER PACK (FM FRONT END)	(E, EB, GC, GN)	S606	EVQ21405R	SW, SELECT (UP)	
Z120	RAL0019	TUNER PACK (FM FRONT END)	(EG)	S607	EVQ21405R	SW, SET	
Z191	RLA6Z005M-T	COMPONENT COMBINATION		S608	EVQ21405R	SW, MEMORY	
		COIL(S)		S609	EVQ21405R	SW, PRESET (DOWN)	
L101	ELESN1ROMA	COIL		S610	EVQ21405R	SW, PRESET (UP)	
L103	ELEXT100KA9	COIL		S611	EVQ21405R	SW, BAND	
L104	ELEXT100KA9	COIL		S612	EVQ21405R	SW, TUNING (DOWN)	
L105, 106	RLQZB822KT-D	COIL		S613	EVQ21405R	SW, TUNING (UP)	
L151	SLM1B10M-1M	COIL	(EG)	S614	EVQ21405R	SW, TUNER	
L191	ELESN1ROMA	COIL		S615	EVQ21405R	SW, CD	
L501, 502	SLQY07G-40	COIL		S616	EVQ21405R	SW, TAPE	
L551, 552	ELEY1ROKA	COIL		S617	EVQ21405R	SW, PHONO	
L601	ELEXT100KA9	COIL		S618	EVQ21405R	SW, DAT	
L701	RLQZ271M	COIL	Δ	S619	EVQ21405R	SW, VDP	
		FILTER(S)		S620	EVQ21405R	SW, VCR	
CF201	RLFFETWND01M	FILTER	(E, EB, GC, GN)	S701	ESE37263	SW, VOLTAGE SELECTOR	Δ (GC)
CF201	RLFFETNGD01L	FILTER	(EG)			CONNECTOR(S)	
CF202	RLFFETWND01M	FILTER	(E, EB, GC, GN)	J703	RWJ1808110XX	FLAT CABLE (8P)	
CF202	RLFFETMGD01L	FILTER	(EG)	J703-1, 2	RJS1A6604	SOCKET (4P)	
		OSCILLATOR(S)		J704A	RJT057W004-1	CONNECTOR (4P)	
X101	RSXZ456KM07M	OSCILLATOR (456KHz)		J704B	RJU057W004	SOCKET (4P)	
X102	RLFDFTD03M	OSCILLATOR (10.7MHz)		CN101, 102	RJU063W07T	SOCKET (7P)	
X103	SVQ49U722-S	OSCILLATOR (7.2MHz)		CN103	RJU057W004	SOCKET (4P)	
X601	RSXA4M19S03	OSCILLATOR (4.19MHz)		CN301	RJU057W004	SOCKET (4P)	
		DISPLAY(S)		CN401-403	SJS50581BB	SOCKET (5P)	
FL601	RSL0152-F	FL DISPLAY	Δ	CN501	RJU057W007	SOCKET (7P)	
		FUSE(S)		CN601-603	RJT003K008-1	CONNECTOR (8P)	
F1	XBA2C16TB0	FUSE 250V T1.6A	Δ (E, EB, EG, GN)	CN701	RJS1A1101T1	SOCKET (1P)	
F1	XBA2C31TB0	FUSE 250V T3.15A	Δ (GC)	CN701A	RJU057W010	SOCKET (10P)	
F2	XBA2C16TB0	FUSE 250V T1.6A	Δ (GC)	CN702	RJS1A1101T1	SOCKET (1P)	
F701, 702	XBA2C16TB0	FUSE 250V T1.6A	Δ	CN702A	RJU057W007	SOCKET (7P)	
		SWITCH(ES)		CN703-708	RJS1A1101T1	SOCKET (1P)	
				CP101, 102	RJT063W07T	CONNECTOR (7P)	
				CP103	RJT057W004-1	CONNECTOR (4P)	
				CP301	RJT057W004-1	CONNECTOR (4P)	
				CP401-403	SJT30549BB1	CONNECTOR (5P)	
				CP501	RJT057W007-1	CONNECTOR (7P)	
				CP601-603	RJU003K008M1	SOCKET (8P)	
				CP701	RJT057W010-1	CONNECTOR (10P)	
				CP702	RJT057W007-1	CONNECTOR (7P)	
						EARTH TERMINAL(S)	

Ref. No.	Part No.	Part Name & Description	Remarks	Ref. No.	Part No.	Part Name & Description	Remarks
E501	SNE1004-1	GND PLATE					
E701	SNE1004-1	GND PLATE				TRANSFORMER(S)	
		FUSE HOLDER(S)		PT701	RTP1N5B016-W	POWER TRANSFORMER	△ (E, EB, EG, GN)
				PT701	RTP1N5G005-W	POWER TRANSFORMER	△ (GC)
FC1-6	EYF52BC	FUSE HOLDER					
FC7, 8	EYF52BC	FUSE HOLDER	(GC)			JACK(S)	
		RELAY(S)		JK101	RJM4202M	ANTENNA TERMINAL	(E, EB, EG)
				JK101	RJM4405-1M	ANTENNA TERMINAL	(GC, GN)
RL701, 702	RSY0013M-0	RELAY	△	JK201	RJT065K15	CONNECTOR (15P)	
RL703	RSY0011-0	RELAY	△ (E, EB, EG, GN)	JK301	RJJD7S2XA-C	HEADPHONES JACK	
		HOLDER(S)		JK351	SJT3213	CONNECTOR (2P)	
				JK401	SJFD7	CENTER SPEAKER TERMINAL	
				JK402	RJJ33T01	CONTROL OUTPUT	
SH401-403	RMRO509	HOLDER		JK501	RJR0054M	SPEAKER TERMINAL	
SH601	RMNO194	FL HOLDER		JK502	SJF3068N	SURROUND SPEAKER TERMINAL	
				JK701	SJS9236	AC INLET	△ (E, EB, EG, GC)
				JK701	SJSD16	AC INLET	△ (GN)
				JK702	SJS702-1	SOCKET (7P)	

Notes : * Capacity values are in microfarads (uF) unless specified otherwise, P=Pico-farads (pF) F=Farads (F)
 * Resistance values are in ohms, unless specified otherwise, 1K=1,000 (OHM) , 1M=1,000k (OHM)

Ref. No.	Part No.	Values & Remarks	Ref. No.	Part No.	Values & Remarks	Ref. No.	Part No.	Values & Remarks
		RESISTORS						
R103	ERDS2TJ271	1/4W 270 E, EB, GC, GN	R129	ERDS2TJ473	1/4W 47K	R195	ERDS2TJ223	1/4W 22K
R103	ERDS2TJ330	1/4W 33 EG	R130, 131	ERDS2TJ102	1/4W 1K	R201, 202	ERDS2TJ222	1/4W 2.2K
R104	ERDS2TJ822	1/4W 8.2K	R132	ERDS2TJ103	1/4W 10K	R203, 204	ERDAS3G223T	1/4W 22K
R105	ERDS2TJ471	1/4W 470	R133-137	ERDS2TJ102	1/4W 1K	R205, 206	ERDS2TJ104	1/4W 100K
R106	ERDS2TJ474	1/4W 470K	R138	ERDS2TJ103	1/4W 10K	R207, 208	ERDAS3G562T	1/4W 5.6K
R107	ERDS2TJ331	1/4W 330	R139, 140	ERDS2TJ272T	1/4W 2.7K	R209, 210	ERDAS3G332T	1/4W 3.3K
R108	ERDS2TJ474	1/4W 470K	R141, 142	ERDS2TJ103	1/4W 10K	R211, 212	ERDS2TJ222	1/4W 2.2K
R109	ERDS2TJ331	1/4W 330	R143, 144	ERDS2TJ222	1/4W 2.2K	R213, 214	ERDS2TJ204	1/4W 200K
R110	ERDS2TJ102	1/4W 1K	R145, 146	ERDS2TJ102	1/4W 1K E, EB, GC, GN	R215, 216	ERDS2TJ474	1/4W 470K
R112	ERDS2TJ104	1/4W 100K	R145, 146	ERDS2TJ821	1/4W 820 EG	R217, 218	ERDS2TJ102	1/4W 1K
R113	ERDS2TJ103	1/4W 10K	R147, 148	ERDS2TJ474	1/4W 470K	R219, 220	ERDS2TJ331	1/4W 330
R114	ERDS2TJ562	1/4W 5.6K	R149	ERDS2TJ680T	1/4W 68	R221, 222	ERDS2TJ105T	1/4W 1M
R115	ERDS2TJ561	1/4W 560	R151-154	ERDS2TJ104	1/4W 100K	R223, 224	ERDS2TJ332	1/4W 3.3K
R116	ERDS2TJ102	1/4W 1K	R155	ERDS2TJ102	1/4W 1K	R225, 226	ERDS2TJ104	1/4W 100K
R117	ERDS2TJ682T	1/4W 6.8K	R156	ERDS2TJ105T	1/4W 1M	R227, 228	ERDS2TJ332	1/4W 3.3K
R118	ERDS2TJ562	1/4W 5.6K	R157, 158	ERDS2TJ102	1/4W 1K	R251, 252	ERDS2TJ102	1/4W 1K
R119	ERDS2TJ392T	1/4W 3.9K E, EB, GC, GN	R159	ERDS2TJ100	1/4W 10	R253, 254	ERDS2EJ121	1/4W 120
R119	ERDS2TJ822	1/4W 8.2K EG	R160, 161	ERDS2TJ331	1/4W 330	R255	ERDS2TJ154	1/4W 150K
R120	ERDS2TJ473	1/4W 47K	R162	ERDS2TJ152	1/4W 1.5K	R256	ERDS2TJ105T	1/4W 1M
R121	ERDS2TJ332	1/4W 3.3K	R163	ERDS2TJ331	1/4W 330	R257	ERDS2TJ334	1/4W 330K
R122	ERDS2TJ272T	1/4W 2.7K	R171, 172	ERDS2TJ102	1/4W 1K	R258	ERDS2TJ105T	1/4W 1M
R124	ERDS2TJ391	1/4W 390	R173	ERDS2TJ471	1/4W 470	R259	ERDS2TJ561	1/4W 560
R125, 126	ERDS2TJ472	1/4W 4.7K	R175	ERDS2TJ102	1/4W 1K	R260	ERDS2TJ392T	1/4W 3.9K
R127	ERDS2TJ103	1/4W 10K	R176	ERDS2TJ391	1/4W 390	R281	ERDS2TJ102	1/4W 1K
R128	ERDS2TJ820	1/4W 82	R191	ERDS2TJ103	1/4W 10K	R282	ERDS2TJ561	1/4W 560
			R192	ERDS2TJ122	1/4W 1.2K	R291, 292	ERDS2TJ104	1/4W 100K
			R193	ERDS2TJ182	1/4W 1.8K	R293, 294	ERDAS3G123T	1/4W 12K
			R194	ERDS2TJ122	1/4W 1.2K	R295, 296	ERDAS3G622T	1/4W 6.2K

Ref. No.	Part No.	Values & Remarks	Ref. No.	Part No.	Values & Remarks	Ref. No.	Part No.	Values & Remarks
R301, 302	ERDS2TJ562	1/4W 5.6K	R511	ERDS2TJ334	1/4W 330K	R799	ERDS2TJ103	1/4W 10K
R303-306	ERDS2TJ563	1/4W 56K	R512 △	ERDS2TJ154	1/4W 150K	R801	ERDS2TJ102	1/4W 1K
R307, 308	ERDS2TJ332	1/4W 3.3K	R513 △	ERDS2TJ684	1/4W 680K	R802	ERDS2TJ222	1/4W 2.2K
R309-312	ERDS2EJ121	1/4W 120	R514 △	ERD25FJ470	1/4W 47	R803	ERDS2TJ103	1/4W 10K
R313, 314	ERDS2TJ102	1/4W 1K	R515, 516△	ERDS1FVJ100T	1/2W 10	R805	ERDS2TJ562	1/4W 5.6K
R315	ERDS2TJ334	1/4W 330K	R517, 518△	ERD25FVJ100T	1/4W 10	R806	ERDS2TJ392T	1/4W 3.9K
R316	ERDS2TJ105T	1/4W 1M	R551, 552	ERDS2TJ222	1/4W 2.2K	R807	ERDS2TJ103	1/4W 10K
R351	ERDS2TJ563	1/4W 56K	R553, 554	ERDS2TJ471	1/4W 470	R808	ERDS2TJ392T	1/4W 3.9K
R352	ERDS2TJ184T	1/4W 180K	R555, 556	ERDS2TJ102	1/4W 1K	R809, 810	ERDS2TJ272T	1/4W 2.7K
R353	ERDS2TJ274	1/4W 270K	R557, 558△	ERDS1FVJ4R7T	1/2W 4.7	R811	ERDS2TJ221	1/4W 220
R354	ERDS2TJ102	1/4W 1K	R559	ERDS2TJ271	1/4W 270	R812	ERDS2TJ332	1/4W 3.3K
R355	ERDS2TJ103	1/4W 10K	R560, 561	ERDS2TJ103	1/4W 10K	R813	ERDS2TJ103	1/4W 10K
R356	ERDS2TJ332	1/4W 3.3K	R571	ERDS2TJ823T	1/4W 82K	R820-822	ERDS2TJ272T	1/4W 2.7K
R357 △	ERDS1FVJ390T	1/2W 39	R572	ERDS2TJ124T	1/4W 120K	R901-903	ERDS2TJ102	1/4W 1K
R358	ERDS2TJ220T	1/4W 22	R573	ERDS2TJ563	1/4W 56K	R1601	ERDS2TJ223	1/4W 22K
R361	ERDS2TJ474	1/4W 470K	R611	ERDS2TJ470	1/4W 47	R1602	ERDS2TJ473	1/4W 47K
R362	ERDS2TJ102	1/4W 1K	R613, 614△	ERDS2TJ101	1/4W 100	R1603	ERDS2TJ223	1/4W 22K
R371	ERDS2TJ103	1/4W 10K	R615 △	ERDS2TJ1R5T	1/4W 1.5	R1604, 1605	ERDS2TJ102	1/4W 1K
R372	ERDS2TJ823T	1/4W 82K	R616-619	ERDS2TJ104	1/4W 100K			CAPACITORS
R373	ERDS2TJ222	1/4W 2.2K	R620	ERDS2TJ221	1/4W 220			
R374	ERDS2TJ823T	1/4W 82K	R621	ERDS2TJ104	1/4W 100K	C101	ECBT1C103NS5	16V 0.01U
R375	ERDS2TJ153	1/4W 15K	R622	ERDS2TJ102	1/4W 1K	C103	ECBT1C103NS5	16V 0.01U
R398	ERDS2TJ332	1/4W 3.3K	R623	ERDS2TJ223	1/4W 22K	C104, 105	ECBT1H102KB5	50V 1000P
R399	ERDS2TJ154	1/4W 150K	R624	ERDS2TJ393	1/4W 39K	C106	ECBT1C103NS5	16V 0.01U
R401, 402	ERDS2TJ222	1/4W 2.2K	R625	ERDS2TJ564	1/4W 560K	C107	ECBT1H473ZF5	50V 0.047U
R403, 404	ERDS2TJ104	1/4W 100K	R626-629	ERDS2TJ223	1/4W 22K	C108	ECBT1H100JC5	50V 10P
R405, 406	ERDS2TJ474	1/4W 470K	R630, 631	ERDS2TJ332	1/4W 3.3K	C109, 110	ECBT1C103NS5	16V 0.01U
R407, 408	ERDS2TJ682T	1/4W 6.8K	R632	ERDS2TJ103	1/4W 10K	C111	ECEA1EKA4R7B	25V 4.7U
R409, 410	ERDS2TJ222	1/4W 2.2K	R634	ERDS2TJ223	1/4W 22K	C112	ECBT1C103NS5	16V 0.01U
R411-414	ERDS2TJ474	1/4W 470K	R635	ERDS2TJ224T	1/4W 220K	C113	ECBT1H102KB5	50V 1000P
R415, 416	ERDS2TJ103	1/4W 10K	R636	ERDS2TJ104	1/4W 100K	C114	ECEA1HKA3R3B	50V 3.3U
R417, 418	ERDS2TJ273	1/4W 27K	R637	ERDS2TJ102	1/4W 1K	C115	ECEA1CKA100B	16V 10U
R419, 420	ERDS2TJ474	1/4W 470K	R639	ERDS2TJ560T	1/4W 56	C116	ECBT1C822MS5	16V 8200P
R421, 422	ERDS2TJ104	1/4W 100K	R660-665	ERDS2TJ102	1/4W 1K	C117	ECQB1H821JF3	50V 820P E, EB, GC, GN
R423, 424	ERDS2TJ221	1/4W 220	R697	ERDS2TJ102	1/4W 1K	C117	ECQP2A221JZT	100V 220P EG
R425	ERDS2TJ332	1/4W 3.3K	R698	ERDS2TJ332	1/4W 3.3K	C118, 119	ECFRIE103KR	25V 0.01U
R426	ERDS2TJ104	1/4W 100K	R699	ERDS2TJ102	1/4W 1K	C120, 121	ECEA1HKA010B	50V 1U
R453	ERDS2TJ561	1/4W 560	R701, 702△	ERD2FCVJ4R7T	1/4W 4.7	C122	ECEA1HKA2R2B	50V 2.2U
R456, 457	ERDS2TJ105T	1/4W 1M	R703, 704	ERDS2TJ562	1/4W 5.6K	C123	ECEA1HKA010B	50V 1U
R458	ERDS2TJ474	1/4W 470K	R705	ERGISJ471E	1W 470	C124	ECBT1H102KB5	50V 1000P
R460	ERDS2TJ561	1/4W 560	R706 △	ERDS1FVJ221T	1/2W 220 E, EB, EG, GN	C125	ECBT1H150JC5	50V 15P
R468	ERDS2TJ562	1/4W 5.6K	R706 △	ERGISJ471E	1W 470 GC	C126	ECBT1H473ZF5	50V 0.047U
R471, 472	ERDS2TJ103	1/4W 10K	R707	ERDS2TJ680T	1/4W 68	C127	ECEA1CKA220B	16V 22U
R483, 484	ERDS2TJ152	1/4W 1.5K	R708	ERDS2TJ562	1/4W 5.6K	C128	ECBT1C103NS5	16V 0.01U
R491, 492	ERDS2TJ104	1/4W 100K	R709, 710	ERGISJ391E	1W 390	C129, 130	ECEA0JKA101B	6.3V 100U
R493, 494	ERDS2TJ272T	1/4W 2.7K	R711, 712	ERGISJ331E	1W 330	C131	ECBT1C103NS5	16V 0.01U
R496, 497	ERDS2TJ221	1/4W 220	R713 △	ERDS1FVJ2R2T	1/2W 2.2	C132	ECBT1H102KB5	50V 1000P
R499	ERDS2TJ103	1/4W 10K	R714	ERGISJ681E	1W 680	C133	ECBT1H150JC5	50V 15P
R501, 502	ERDS2TJ222	1/4W 2.2K	R715	ERDS2TJ153	1/4W 15K	C134	ECBT1H180JC5	50V 18P
R503-506	ERDS2TJ563	1/4W 56K	R716	ERDS2TJ102	1/4W 1K	C135, 136	ECBT1C822MS5	16V 8200P
R507, 508	ERDS2TJ272T	1/4W 2.7K	R717	ERDS2TJ103	1/4W 10K	C137, 138	ECBT1H271KB5	50V 270P
R509, 510	ERDS2TJ102	1/4W 1K	R721, 722	ERGISJ271E	1W 270 E, EB, EG, GN			

Ref. No.	Part No.	Values & Remarks	Ref. No.	Part No.	Values & Remarks	Ref. No.	Part No.	Values & Remarks
C139, 140	ECFR1E562KR	25V 5600P E, EB, GC, GN	C413, 414	ECBT1H101KB5	50V 100P	C709	ECBT1E103ZF	25V 0.01U
C139, 140	ECFR1E822KR	25V 8200P EG	C415, 416	ECEA1CKA100B	16V 10U	C710	ECA1HM470B	50V 47U
C141-144	ECEA1HKA010B	50V 1U	C417, 418	ECEA1HKA3R3B	50V 3.3U	C711 Δ	ECQE1104KF3	100V 0.1U
C145	ECBT1H220JC5	50V 22P	C419, 420	ECBT1H470J5	50V 47P	C712	ECBT1E223ZF	25V 0.022U
C146	ECBT1H331KB5	50V 330P	C421, 422	ECEA1CKA100B	16V 10U	C714, 715Δ	ECKR1H103ZF5	50V 0.01U
C147	ECBT1H102KB5	50V 1000P	C423-426	ECEA1HKA3R3B	50V 3.3U	C751 Δ	ECKWNS103ZVS	500V 0.01U E, EB, EG, GN
C148	ECBT1C103NS5	16V 0.01U	C451	ECEA1CKA100B	16V 10U	C801, 802	ECBT1H470J5	50V 47P
C149	ECBT1H104ZF5	50V 0.1U	C452	ECEA0JKA470B	6.3V 47U	C803	ECBT1H104ZF5	50V 0.1U
C151	ECEA1HKA010B	50V 1U	C481-484	ECBT1E103ZF	25V 0.01U	C810	ECBT1H470J5	50V 47P
C152	ECKR1H103ZF5	50V 0.01U	C488-491	ECBT1E103ZF	25V 0.01U	C811	ECBT1E103ZF	25V 0.01U
C153	ECEA1AKA101B	10V 100U	C494	ECBT1H470J5	50V 47P	C821, 822	ECBT1H220J5	50V 22P
C155, 156	ECBT1E103ZF	25V 0.01U	C495-497	ECBT1E103ZF	25V 0.01U	C901-903	ECBT1H101KB5	50V 100P
C157, 158	ECBT1H101KB5	50V 100P	C498	ECBT1H470J5	50V 47P	C905, 906	ECBT1H101KB5	50V 100P
C171	ECBT1C103NS5	16V 0.01U	C499	ECBT1E103ZF	25V 0.01U	C907, 908	ECBT1E223ZF	25V 0.022U
C172	ECBT1H331KB5	50V 330P	C501, 502	ECA1HAP3R3B	50V 3.3U	C911 Δ	ECKR1H102ZF5	50V 1000P
C173	ECEA1CKA220B	16V 22U	C503, 504	ECBT1H331KB5	50V 330P	C950	ECBT1H101KB5	50V 100P
C174	ECEA1CKA100B	16V 10U E, EB, GC, GN	C505, 506	ECBT1H6R8K5	50V 6.8P	C1101, 1102	ECBT1E223ZF	25V 0.022U
C174	ECEA1CKA101B	16V 100U EG	C507, 508	ECBT1H102KB5	50V 1000P	C1103-1106	ECBT1H102KB5	50V 1000P
C181	ECBT1H471KB5	50V 470P EG	C509, 510	ECA1HAP3R3B	50V 3.3U	C1107, 1108	ECBT1E223ZF	25V 0.022U
C201, 202	ECBT1H101KB5	50V 100P	C511, 512	ECBT1H821KB5	50V 820P	C1109-1111	ECBT1H102KB5	50V 1000P
C203, 204	ECQB1H393JF3	50V 0.039U	C513	ECA1HAP330B	50V 33U			
C205, 206	ECQB1H333JF3	50V 0.033U	C514	ECA2AAP100B	100V 10U			
C207, 208	ECBT1H471KB5	50V 470P	C515, 516	ECBT1H104ZF5	50V 0.1U			
C209, 210	ECEA1HKA3R3B	50V 3.3U	C551, 552	ECBT1H221KB5	50V 220P			
C211, 212	ECBT1H101KB5	50V 100P	C553, 554	ECEA1HKA3R3B	50V 3.3U			
C213, 214	ECQB1H103JF3	50V 0.01U	C555, 556	ECEA0JKA101B	6.3V 100U			
C215-218	ECBT1H101KB5	50V 100P	C557, 558	ECA1VM101B	35V 100U			
C219, 220	ECEA1CKA100B	16V 10U	C559, 560	ECQV1H473JM3	50V 0.047U			
C221, 222	ECQB1H333JF3	50V 0.033U	C561	ECEA1EU221	25V 220U			
C251	ECEA0JKA221B	6.3V 220U	C562 Δ	ECEA1HKN010B	50V 1U			
C252	ECEA1CKA100B	16V 10U	C563	ECQV1H104JM3	50V 0.1U			
C281-287	ECBT1E103ZF	25V 0.01U	C571	ECEA0JKA101B	6.3V 100U			
C291, 292	ECQB1H223JF3	50V 0.022U	C599	ECBT1C103MS5	16V 0.01U			
C293, 294	ECBT1H101KB5	50V 100P	C601	ECEA0JU102	6.3V 1000U			
C301, 302	ECEA1HKA3R3B	50V 3.3U	C602	ECBT1E223ZF	25V 0.022U			
C303, 304	ECBT1H101KB5	50V 100P	C603	ECEA1CKS100L	16V 10U			
C305, 306	ECBT1H330J5	50V 33P	C604 Δ	ECEA1VKA330B	35V 33U			
C307, 308	ECEA1HKA3R3B	50V 3.3U	C605	ECEA1VKA330B	35V 33U			
C309	ECEA1HKA010B	50V 1U	C607	ECEA1HKS010	50V 1U			
C351	ECEA1CKA100B	16V 10U	C608	ECEA1HKA2R2B	50V 0.22U			
C352	ECBT1E223ZF	25V 0.022U	C609, 610	ECBT1E103ZF	25V 0.01U			
C353	ECEA1HKA2R2B	50V 2.2U	C611	ECBT1H102KB5	50V 1000P			
C361 Δ	ECEA1CM470SB	16V 47U	C612	ECBT1E223ZF	25V 0.022U			
C371	ECEA0JKA221B	6.3V 220U	C620 Δ	ECEA1HKS010	50V 1U			
C381, 382	ECBT1E103ZF	25V 0.01U	C621, 622	ECBT1H200JC5	50V 20P			
C397, 398	ECBT1E103ZF	25V 0.01U	C698, 699	ECBT1E103ZF	25V 0.01U			
C401, 402	ECBT1H101KB5	50V 100P	C701, 702	ECEA45V472YB	45V 4700U			
C403, 404	ECEA1CKA100B	16V 10U	C703, 704	ECEA1CKA330B	16V 33U			
C405, 406	ECEA1HKA3R3B	50V 3.3U	C705, 706	ECKR1H103ZF5	50V 0.01U			
C407, 408	ECBT1H101KB5	50V 100P	C707	ECA1HM471B	50V 470U E, EB, EG, GN			
C409, 410	ECEA1CKA100B	16V 10U	C707	ECA1HM221B	50V 220U GC			
C411, 412	ECEA1HKA3R3B	50V 3.3U	C708	ECEA1CKA100B	16V 10U			

Ref. No.	Part No.	Part Name & Description	Remarks
		CABINET PARTS	
1	RHD30007	SCREW	
2	RKMD202A-1K	CABINET	
3	XTBS3+8JFZ1	SCREW	
4	RWJ1808110XX	FLAT CABLE (8P)	
5	RGW0157-K	KNOB, MAIN VOLUME	
6	RGW0158-K	KNOB, SURROUND/CENTER	
7	RFKJACH550PK	BOTTOM BOARD ASS'Y	(E, EB, EG, GN)
7	RFKJACH550GC	BOTTOM BOARD ASS'Y	(GC)
7-1	RKA0055-N	FOOT	
8	RFKHACH950EK	REAR GRILL ASS'Y	(E)
8	RFKHACH950EB	REAR GRILL ASS'Y	(EB)
8	RFKHACH950EG	REAR GRILL ASS'Y	(EG)
8	RFKHACH950GC	REAR GRILL ASS'Y	(GC)
8	RFKHACH950GN	REAR GRILL ASS'Y	(GN)
9	RMCO158	TRANSISTOR HOLDER	
10	RMCO182	EARTH PLATE	(EG)
10	RMCO164	EARTH PLATE	(E, EB, GC, GN)
11	RMNO190	HOLDER (A)	
12	RMNO191-1	HOLDER (B)	
13	RMNO194	FL HOLDER	
14	RFKGACH950EK	FRONT PANEL ASS'Y	
15	RGUD796-K	BUTTON, INPUT SELECTOR	
16	RGUD797-K	BUTTON, POWER	
17	XTBS26+8J	SCREW	
18	XTWS3+10T	SCREW	
19	SHE187-2	P. C. B. SPACER	
20	SNE4021-1	NUT	
21	XTBS3+8JFZ1	SCREW	
22	XTB3+12JFZ	SCREW	
23	XTB3+20JFZ	SCREW	
24	XTB3+8JFZ	SCREW	
25	XTW3+15T	SCREW	
26	XTW3+8T	SCREW	
27	RMNO195	FL SPACER	
28	RMQ0260	HOLDER (L)	
29	RMQ0261	HOLDER (R)	
30	RMRO509	HOLDER	
31	RMNO215	FAN ANGLE	
32	SYE1128-2	FAN ASS'Y	
32-1	SHE232	FAN	
32-2	SJS271	SPRING	
32-3	SHE233-1	FAN CASE	
32-4	MDN-4RB4MRC	MOTOR	
32-5	SHE234	CAP	
32-6	SJT783	TERMINAL	
32-7	SJS5215	CONNECTOR (2P)	
33	RMCO197	EARTH PLATE	(EG)

Ref. No.	Part No.	Part Name & Description	Remarks
		PACKING MATERIALS	
P1	RPG1413	PACKING CASE (SYSTEM)	(E, EG)
P1	RPG1414	PACKING CASE (SYSTEM)	(EB)
P1	RPG1455	PACKING CASE (SYSTEM)	(GC)
P1	RPG1415	PACKING CASE (SYSTEM)	(GN)
P2	RPG1314	PACKING CASE (CD/PROCESSOR)	
P3	RPG1312	PACKING CASE (AMPLIFIER)	
P4	RPG1313	PACKING CASE (DECK)	
P5	RPN0627	PAD (CD/PROCESSOR)	
P6	RPN0625	PAD (AMPLIFIER)	
P7	RPN0626	PAD (DECK)	
P8	RPQF0047	ACCESSORY BOX	
P9	RPQ0244	SPACER	
P10	XZB45X50A01Z	PROTECTION COVER	
P11	XZB22X20C03	PROTECTION COVER	
		ACCESSORIES	
A1	RAK-SC707WH	REMOTE CONTROL TRANSMITTER	
A1-1	RKK0020-K	BATTERY COVER	
A2	RFKSACH950EK	INSTRUCTIONS MANUAL	(E)
A2	RFKSACH950EB	INSTRUCTIONS MANUAL	(EB)
A2	RFKSACH950EG	INSTRUCTIONS MANUAL	(EG)
A2	RFKSACH950GC	INSTRUCTIONS MANUAL	(GC)
A2	RFKSACH950GN	INSTRUCTIONS MANUAL	(GN)
A3	RQA0013	WARRANTY CARD	(E, EB, EG)
A3	RQX7433ZA	WARRANTY CARD	(GN)
A4	RQCB0169	SERVICE CENTER LIST	
A5	REX0462	FLAT CABLE (15P)	
A6	RJA0019-2K	AC POWER SUPPLY CORD	△ (E, EG, GC)
A6	VJA0733	AC POWER SUPPLY CORD	△ (EB)
A6	SJA173	AC POWER SUPPLY CORD	△ (GN)
A7	RSAD007	FM INDOOR ANTENNA	(E, EB, EG)
A7	RSAD006	FM INDOOR ANTENNA	(GC, GN)
A8	SPB1163T	LW/MW LOOP ANTENNA	
A8-1	SMA233-1M	ANTENNA HOLDER	
A8-2	XTN3+10AFZ	SCREW	
A9	SWXS257M	SPEAKER CORD	
A10	RJL1P001B25	SURROUND SPEAKER CORD	
A11	SJP9009	ATTACHMENT PLUG	△ (EB)
A12	SJP5213-2	POWER PLUG ADAPTOR	△ (GC)

PACKAGING

904

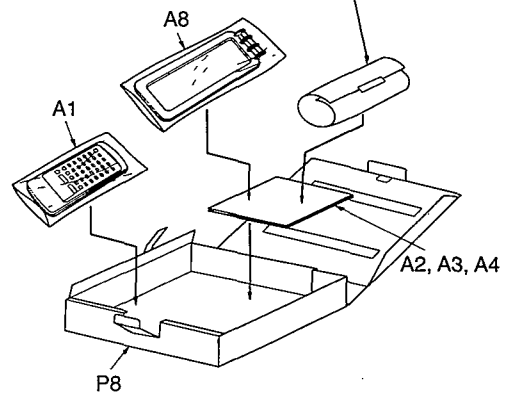
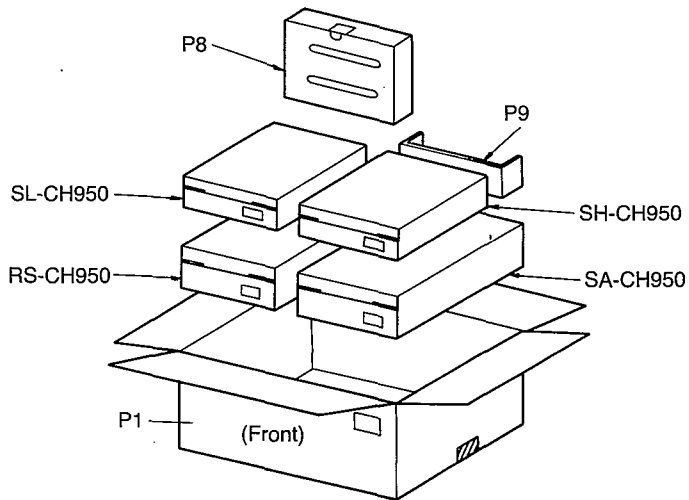
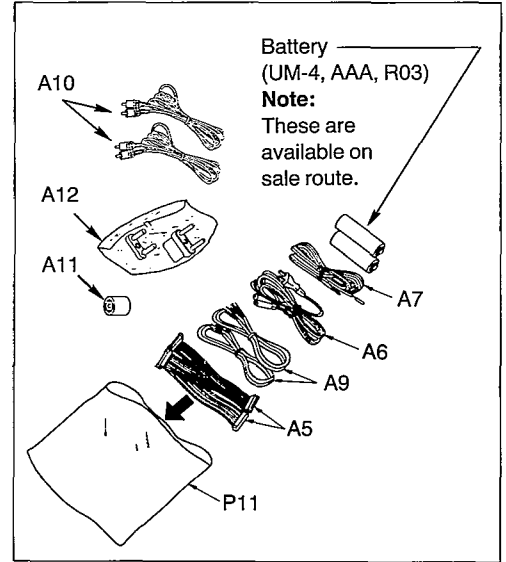
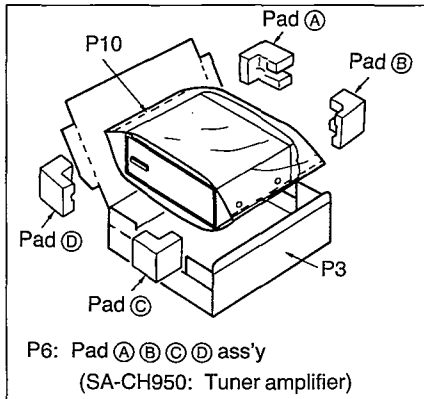
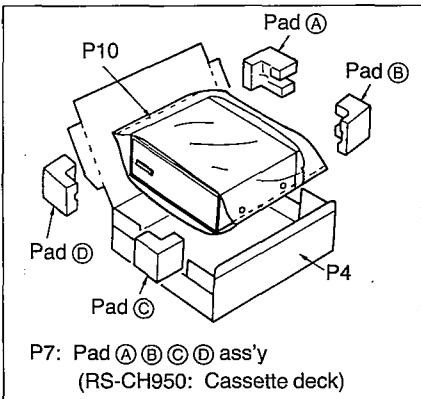
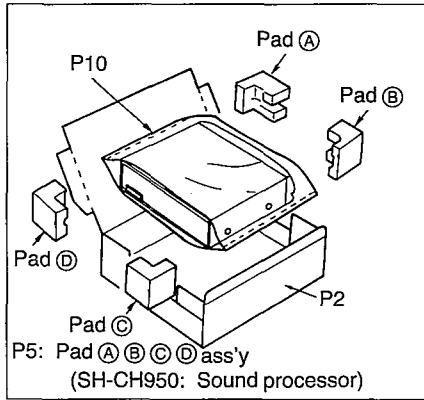
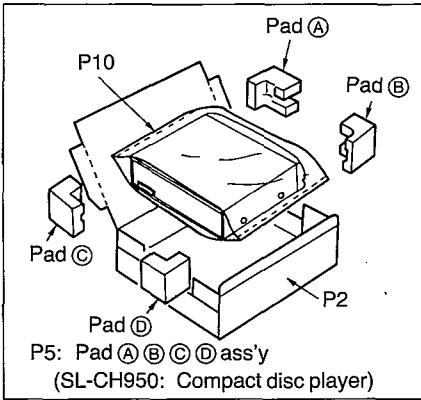

E-BOARD TNP197087

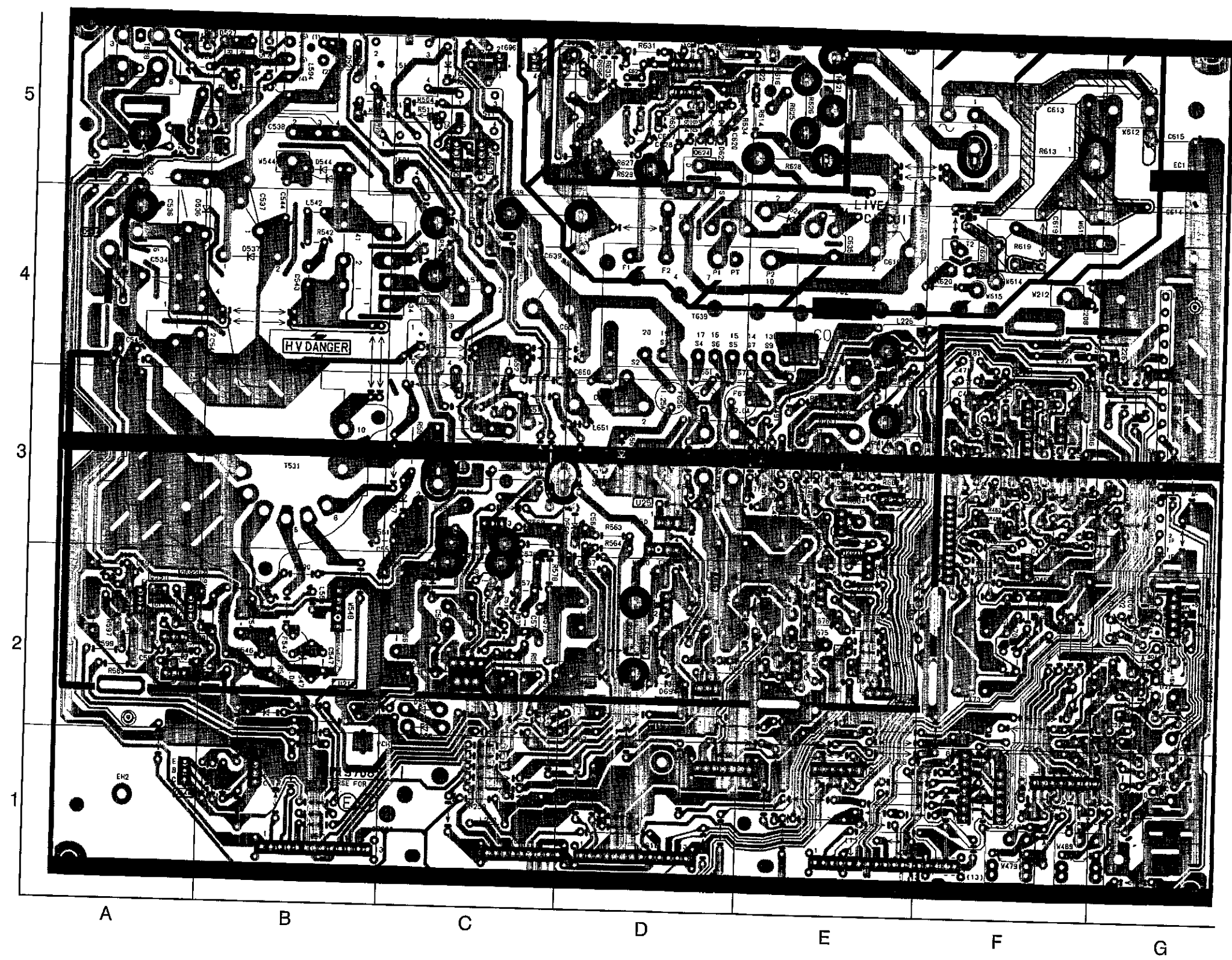

DIODES	TRANS
D206	G2 Q463 E3
D465	G3 Q465 F2
D466	E3 Q494 E3
D467	E3 Q496 F4
D471	F3 Q497 F3
D481	F3 Q498 F3
D491	E3 Q506 C5
D502	C5 Q507 C5
D507	C4 Q524 D5
D508	C4 Q526 B5
D513	E5 Q543 B1
D521	B5 Q544 A1
D526	A5 Q591 A2
D527	B5 Q592 A2
D536	A4 Q593 A2
D537	B4 Q594 A2
D544	B5 Q651 C3
D548	B2 Q667 E2
D549	A3 Q674 E2
D557	C3 Q681 E3
D561	C2 Q682 F3
D562	C2
D563	D3 IC'S
D564	B2 I561 C2
D565	C2 I611 D5
D566	C2 I661 D2
D567	D2 I676 E2
D568	C2 I691 D2
D569	C2 I696 C5
D591	A2
D622	D5
D624	E4
D630	D5
D636	C5
D651	D3
D656	D3
D661	D3
D671	D3
D678	E2
D681	E4
D686	E3
D689	E3
D694	D2

M BOARD TNP8EM012

DIODES	TRANS
D6101	G1 Q6111 G2
D6103	G2 Q6114 G2
D6106	F3 Q6301 I3
D6301	J3 Q6403 I1
D6381	I3 Q6413 H1
D6382	I3 Q6417 H2
D6391	J2 Q6433 I2
D6392	J2 Q6443 I2
D6491	J2 Q6447 H2
D6492	J2
D6591	J1 I.C.s
D6592	J1 I6101 G2
	I6301 I4

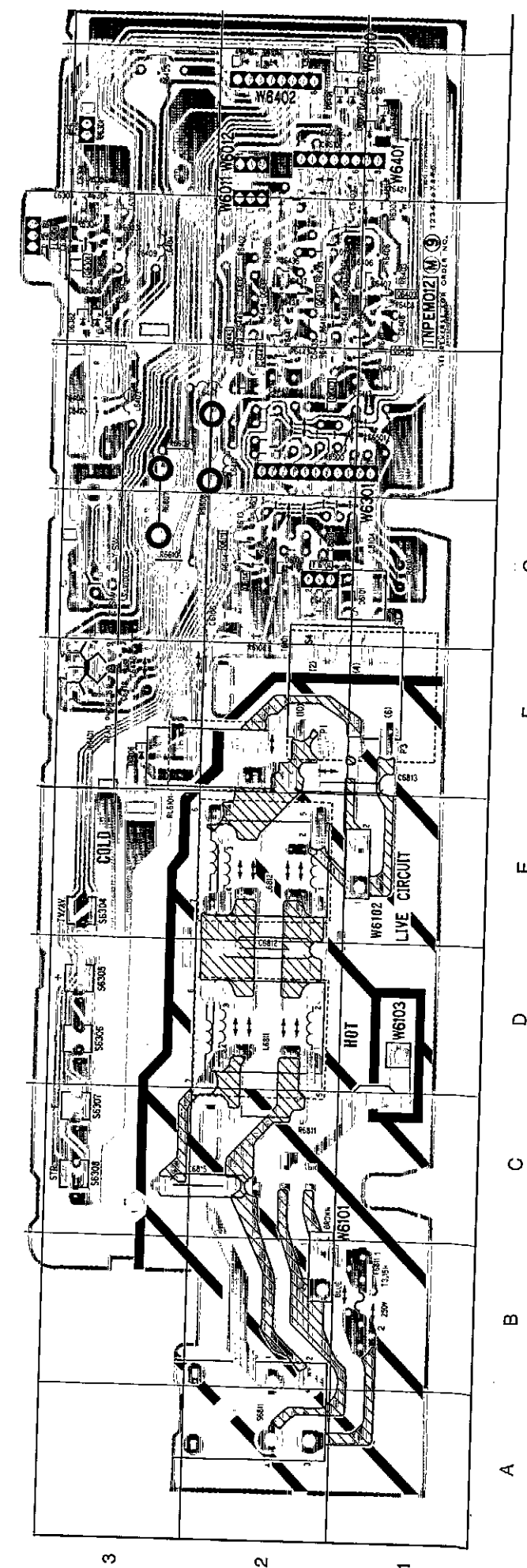

E BOARD
TNP197087

