

# ROTEL *hifi*

---

STEREO POWER AMPLIFIER

# RB-960BX

---

# TECHNICAL MANUAL

## TABLE OF CONTENTS

Alignment.....	1
Chassis Layout.....	1
Specifications.....	2
Printed Circuit Boards.....	3
Schematic Diagram.....	4
Wiring Diagram.....	5
PC Board Ass'y Parts List.....	6

**THE ROTEL CO., LTD.**

1-36-8, OHOKAYAMA, MEGURO-KU, TOKYO 152, JAPAN

**ROTEL ELECTRONICS CO., LTD.**

3F-2, NO 35, FU HSING NORTH ROAD, TAIPEI, TAIWAN, REPUBLIC OF CHINA

MN20001901

# Power Amplifier Bias Adjustment

Instruments: DC milli-voltmeter

Notes: Prior to Bias Adjustment, run about 5 minutes with rated output (8 ohm) and warm up Power Transistor and Heat Sink.  
Set Volume control to minimum.

Step	Coupling		Adjust	Adjust for
	Plus Lead	Minus Lead		
1	TP3	TP1	VR601	DC milli-voltmeter reads 4 mV
2	TP4	TP2	VR602	

## Chassis Layout

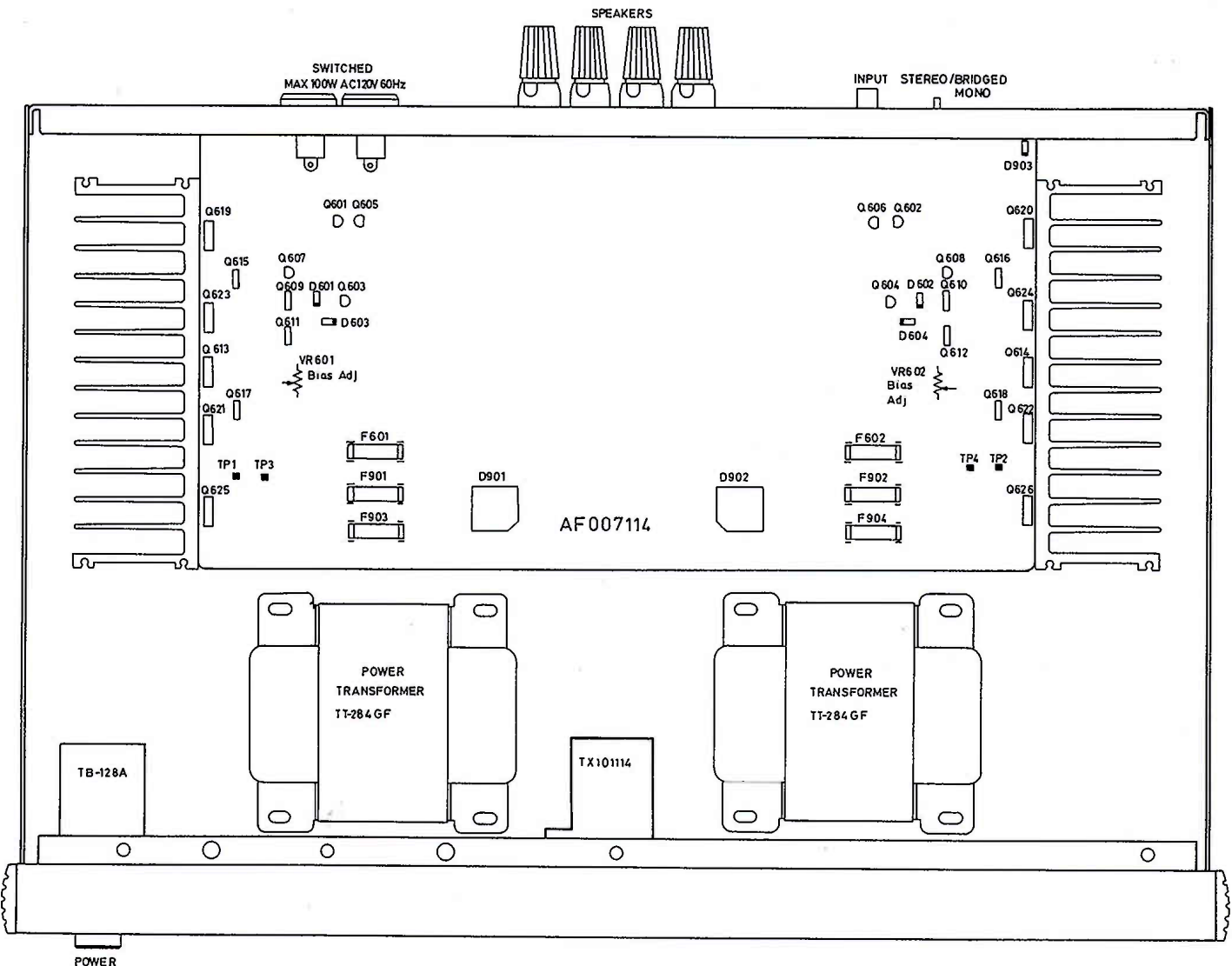

# Specifications

RB-960BX

Continuous Power Output...60 watts\* per channel, min.  
RMS both channels driven into  
8 ohms from 20 to 20,000 Hz  
with no more than 0.03% total  
harmonic distortion.

DIN Output.....110 watts per channel (1 kHz, 4  
ohms, 1% THD)

Peak Current.....30 A (0.1 ohms, 10 usec,  
1 pulse)

Power Output (BTL).....180 watts (mono) min. RMS  
driven into 8 ohms from 20 to  
20,000 Hz with no more than  
0.03% total harmonic distortion.

Total Harmonic Distortion...No more than 0.03% (contin-  
(20 to 20,000Hz) uous rated power output) No  
more than 0.03% (continuous  
1/2 rated power output) No  
more than 0.05% (1 watt per  
channel power output, 8 ohms)

Intermodulation Distortion...No more than 0.05% (contin-  
(60 Hz: 7 kHz = 4:1) uous rated power output) No  
more than 0.05% (continuous  
1/2 rated power output) No  
more than 0.05% (1 watt per  
channel power output, 8 ohms)

Output: Speaker.....8 ohms nominal  
Damping Factor.....280 (20 to 20,000 Hz, 8 ohms)  
Input Sensitivity/ Impedance.....1.0 V/ 27 kohms  
Frequency Response.....15 to 100,000 Hz, +0 dB, -1.0  
dB  
Signal to Noise Ratio.....116 dB  
(IHF, A network)

## MISCELLANEOUS

Power Requirement.....120 V/ 60 Hz, 220 V/ 50 Hz,  
,240 V/ 50 Hz (depending on  
destinations)  
Power Consumption.....300 watts  
Dimensions (overall).....440 (W) x 92 (H) x 334 (D) mm,  
17-3/8" x 3-5/8" x 13-3/16"  
Weight (net).....9.2 kg / 20.2 lbs.

- Specifications and design subject to possible modifica-  
tion without notice.
- \*Measured pursuant to the Federal Trade Commis-  
sion's Trade Regulation Rule or, Power Claims for  
Amplifiers (applicable to the U.S.A. only).

# Printed Circuit Boards

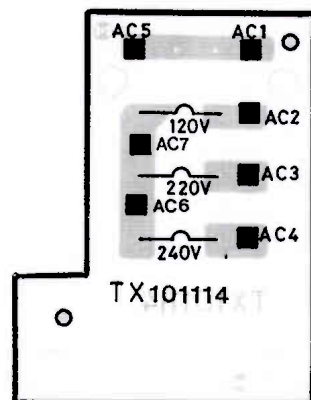
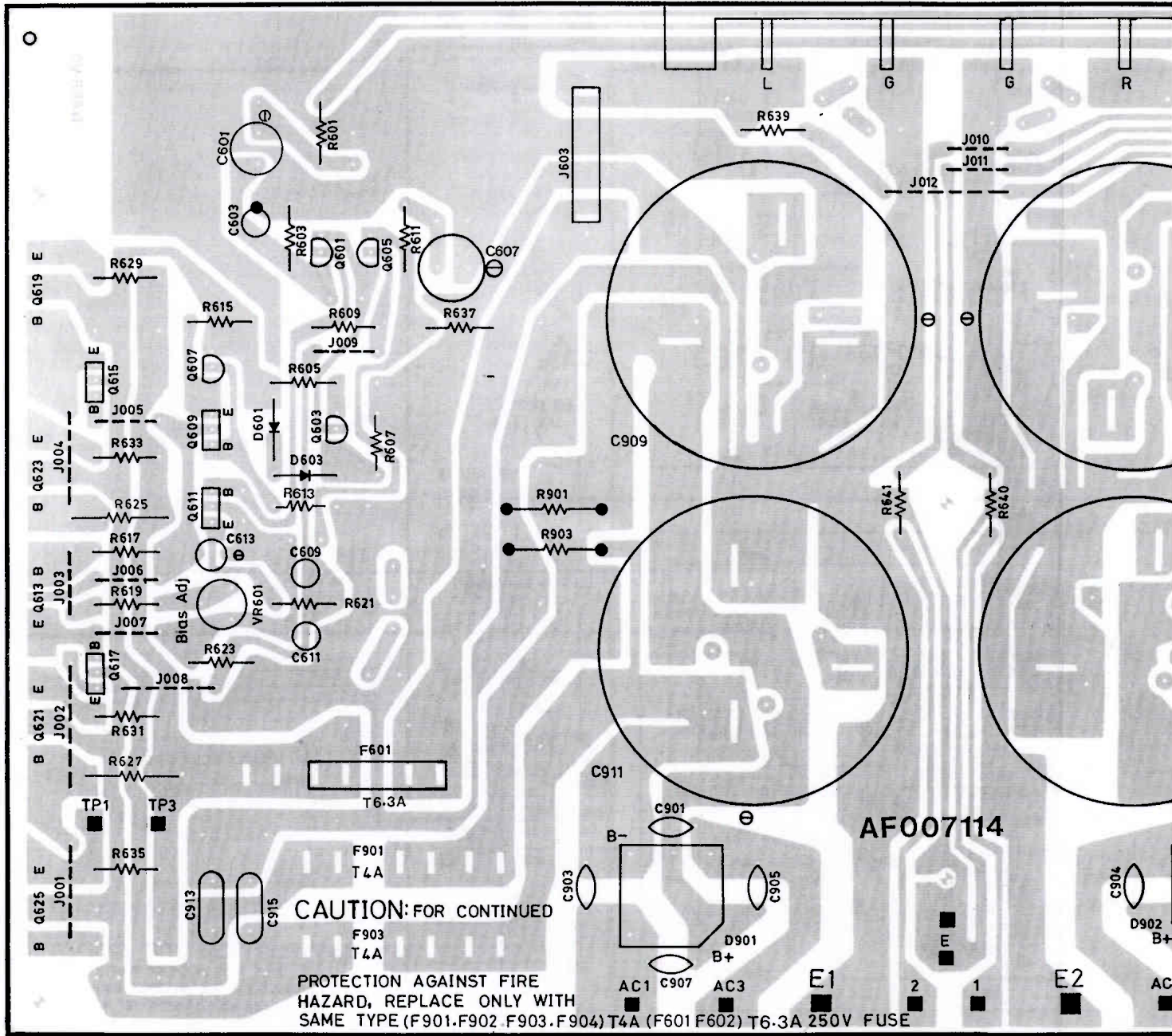

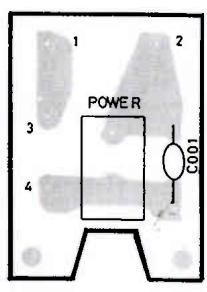
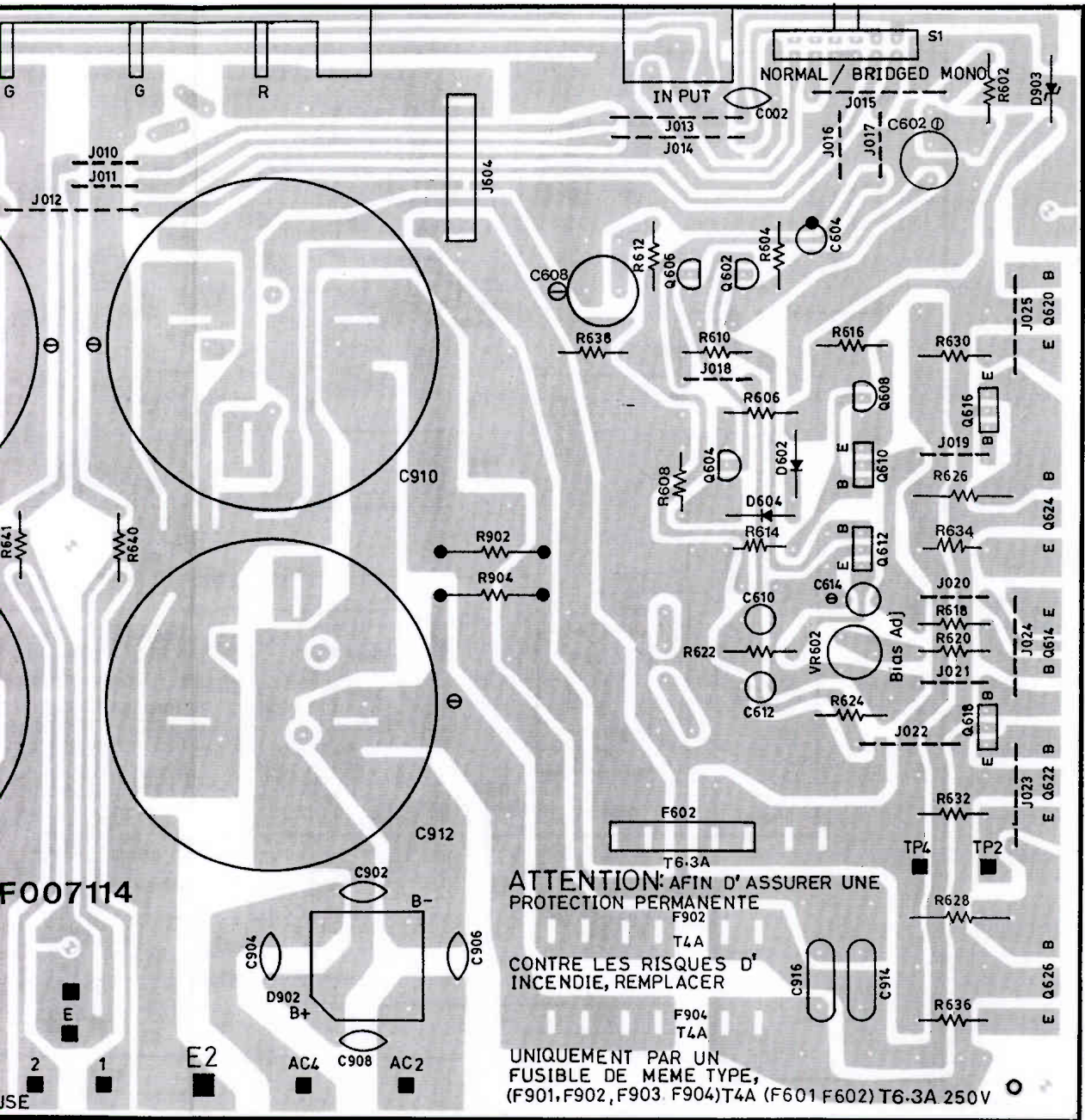

# Schematic Diagram

## SCHEMATIC DIAGRAM MOD

NOTE: PARTS AND CIRCUIT SUBJECT TO CHANGES FOR IMPROVEMENT

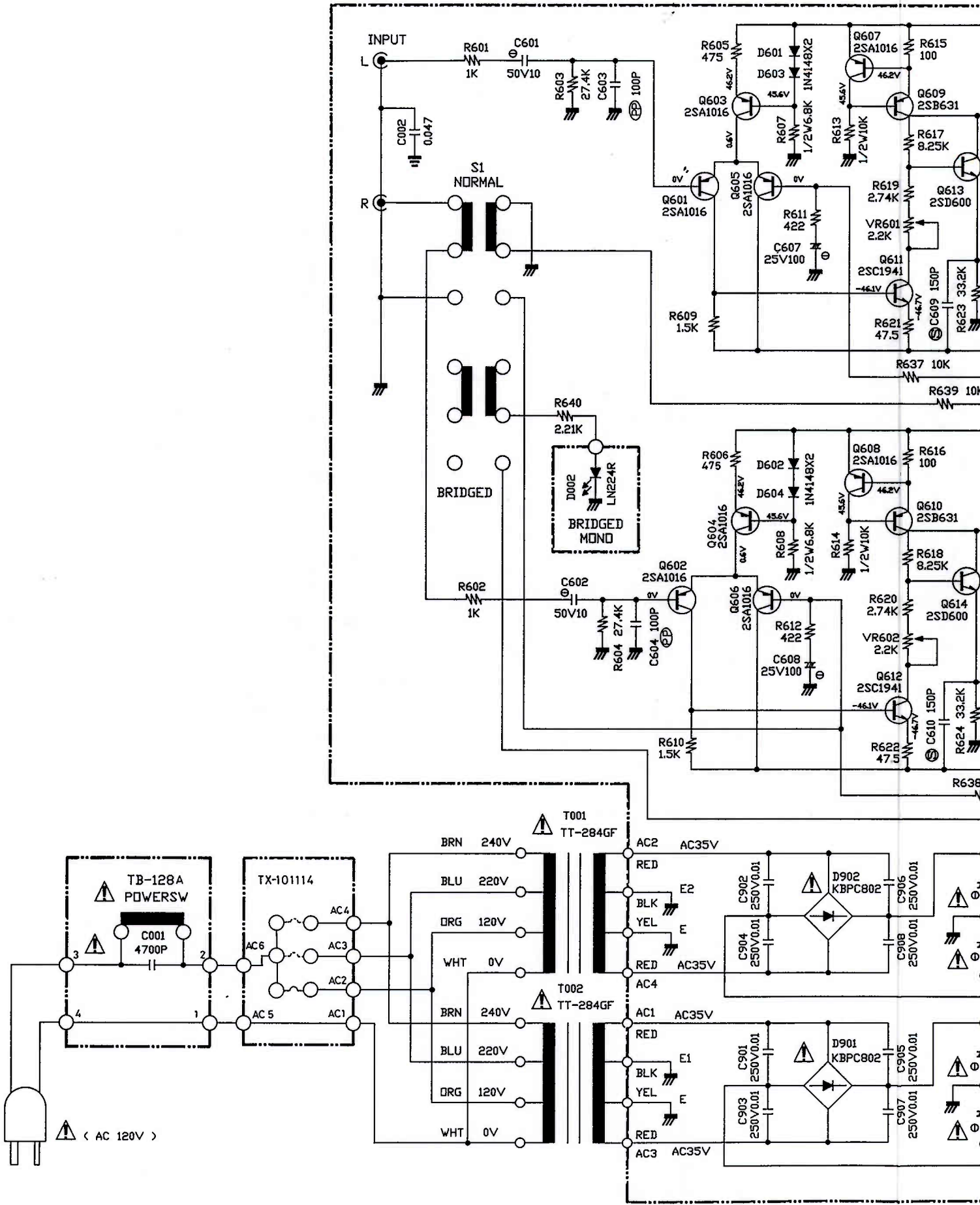

# MODEL RB-960BX

IMPROVEMENTS WITHOUT PRIOR NOTICE

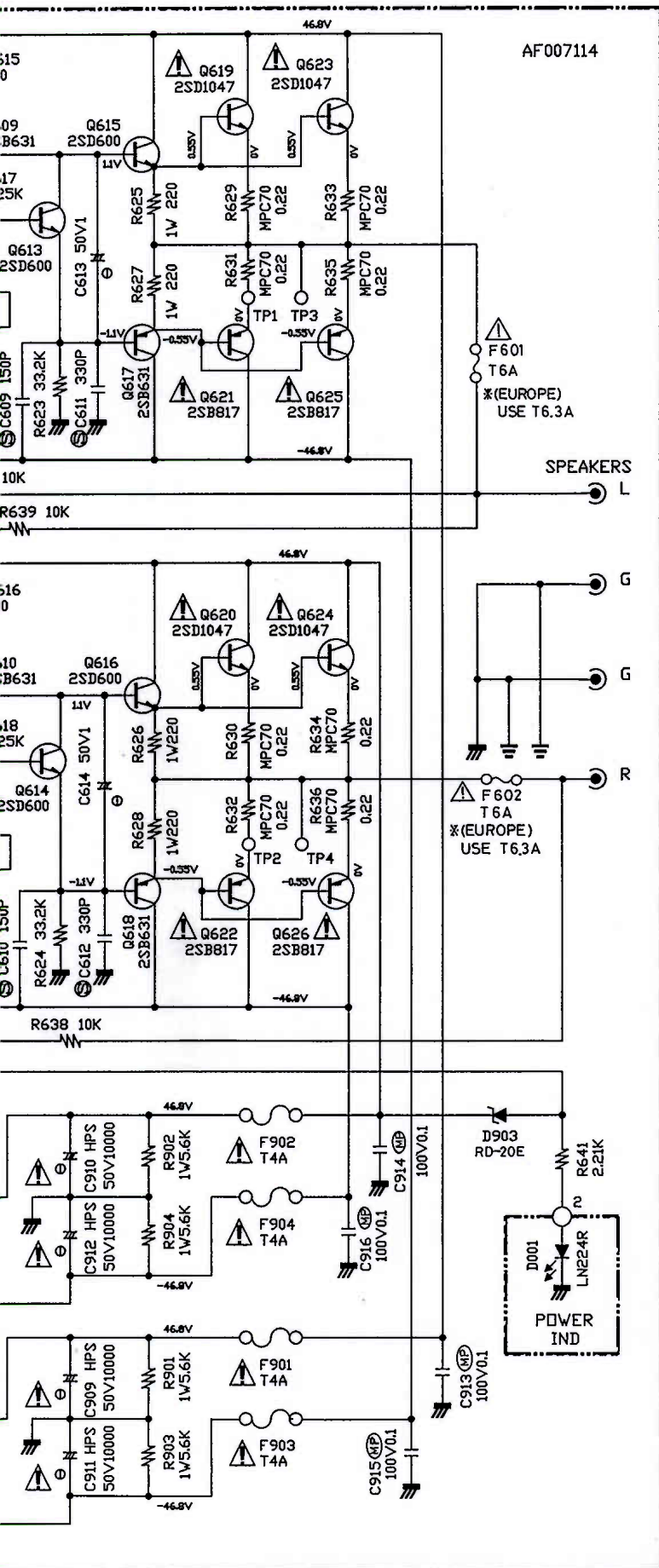

## INSTRUCTION FOR SERVICING PERSONNEL:

- 1). USE ONLY REPLACEMENT PARTS THAT HAVE THE CRITICAL CHARACTERISTICS RECOMMENDED BY MANUFACTURER.
- 2). MAKE LEAKAGE-CURRENT OR RESISTANCE MEASUREMENTS TO DETERMINE THAT EXPOSED PARTS ARE ACCEPTABLY INSULATED FROM THE AC SUPPLY CIRCUIT BEFORE RETURNING THE UNIT TO THE CUSTOMER.

• 2SA1016



• 2SC1941

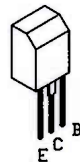

• 2SD600

• 2SB631



• 2SD1047

• 2SB817

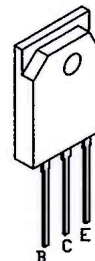

# Wiring Diagram

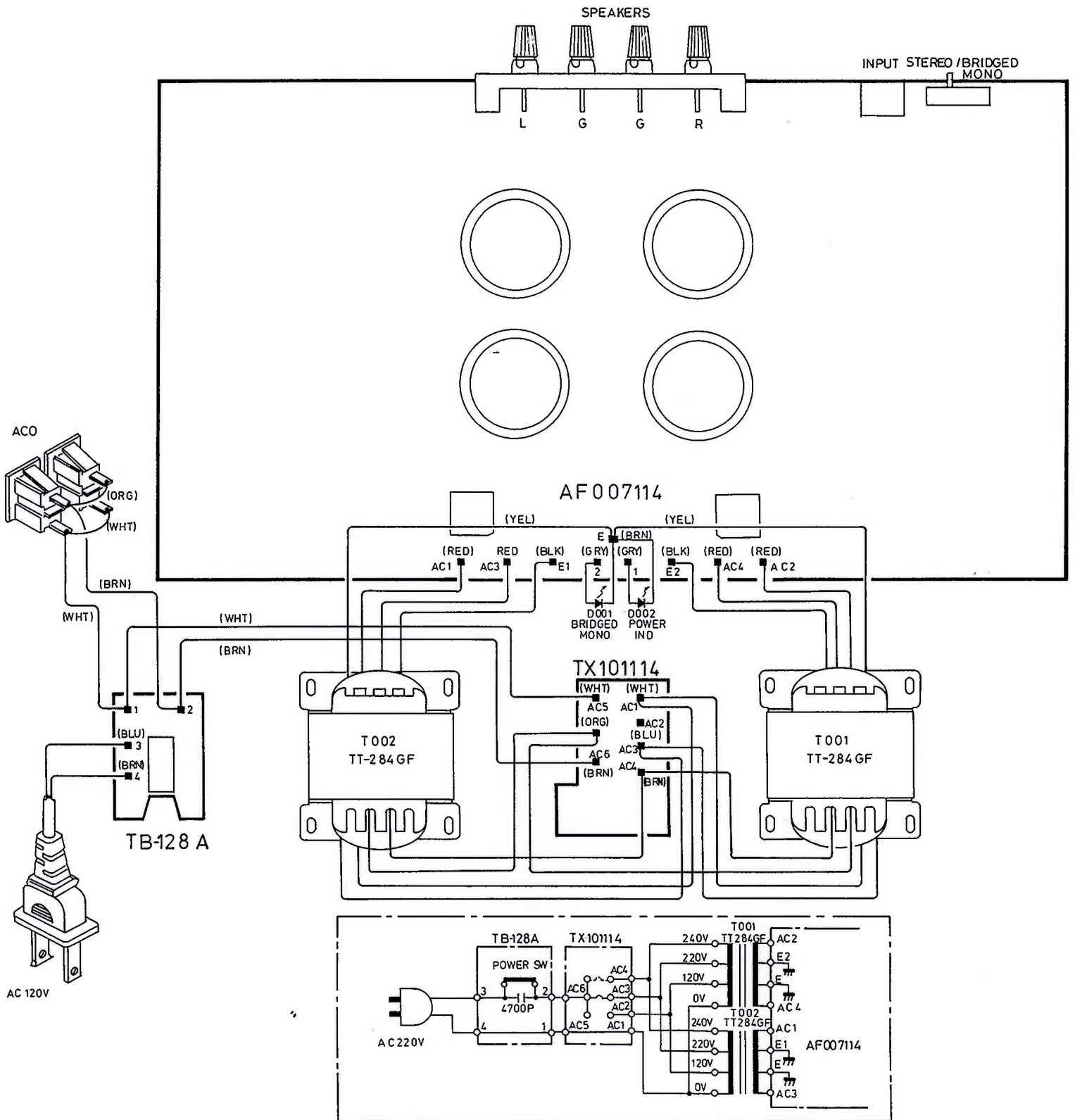



# Parts List

NOTE: THE COMPONENTS INDENTIFIED BY  $\Delta$  MARK ARE FOR SAFFTY. REPLACE ONLY WITH ORIGINAL PARTS. DO NOT SUBSTITUTE.

SYMBOL	PARTS NO.	DESCRIPTION
AF007114 PCB ASSEMBLY		
R601, 602	RM81001612	R, STANDARD METAL MK2001KFECZ.
R603, 604	RM82742619	R, STANDARD METAL MK227K4FECZ.
R605, 606	RM84750619	R, STANDARD METAL MK2475RFECZ.
R607, 608	RM96801925	R, METAL 6.8K 1/2W J
R609, 610	RM81501610	R, STANDARD METAL MK201K5FECZ.
R611, 612	RM84220618	R, STANDARD METAL MK2422RFECZ.
R613, 614	RM91002923	R, METAL 10K 1/2W J
R615, 616	RM81000619	R, STANDARD METAL MK2100RFECZ.
R617, 618	RM88251610	R, STANDARD METAL MK28K25FECZ.
R619, 620	RM82741615	R, STANDARD METAL MK22K74FECZ.
R621, 622	RM84759611	R, STANDARD METAL MK247R5FECZ.
R623, 624	RM83322614	R, STANDARD METAL MK233K2FECZ.
R625, 626	RM92200121	R, METAL 220 1W J
R627, 628	RM92200121	R, METAL 220 1W J
R629, 630	RS20228230	R, SQUARE TYPE MPC70-0.22F
R631, 632	RS20228230	R, SQUARE TYPE MPC70-0.22F
R633, 634	RS20228230	R, SQUARE TYPE MPC70-0.22F
R635, 636	RS20228230	R, SQUARE TYPE MPC70-0.22F
R637, 638	RM81002616	R, STANDARD METAL MK2010KFECZ.
R639	RM81002616	R, STANDARD METAL MK2010KFECZ.
R640, 641	RM82211614	R, STANDARD METAL MK22K21FECZ.
C601, 602	CE51006477	CAP, ELAC. 50BGF10M
C603, 604	CP71011353	CAP, P.P 100V101H
C605, 606	CE51005679	CAP, ELEC. 25BGF100M
C609, 610	CS41511420	CAP, STYROL 150P F 50V J
C611, 612	CS43311421	CAP, STYROL 330P F 50V J
C613, 614	CE01007504	CAP, ELEC. 50V 1uF
D601, 602	DD80000021	DIODE IN4148-86
D603, 604	DD80000021	DIODE IN4148-86
Q601, 602	TR10000023	TRANSISTOR 2SA1016 (F)
Q603, 604	TR10000023	TRANSISTOR 2SA1016 (F)
Q605, 606	TR10000023	TRANSISTOR 2SA1016 (F)
Q607, 608	TR10000023	TRANSISTOR 2SA1016 (F)
Q609, 610	TR10000047	TRANSISTOR 2SB631K (E, F)
Q611, 612	TR30000169	TRANSISTOR 2SC1941 (K, L)
Q613, 614	TR40000069	TRANSISTOR 2SD600K (E)
Q615, 616	TR40000069	TRANSISTOR 2SD600K (E)
Q617, 618	TR10000047	TRANSISTOR 2SB631K (E, F)
Q619, 620	TR40000045	POWER TRANSISTOR 2SD1047
Q621, 622	TR20000040	POWER TRANSISTOR 2SB817
Q623, 624	TR40000045	POWER TRANSISTOR 2SD1047
Q625, 626	TR20000040	POWER TRANSISTOR 2SB817
VR601, 602	RV40000022	R, SEMI-FIXED VM6CKPV-13-B
F601, 602	FU25000041	FUSE 125V 6A C, U, H, J $\Delta$
	FU230000219	FUSE 250V 6.3A $\Delta$
R901-904	RM95601126	R, METAL 5.6K 1W
C901-908	CC01009256	CAP, CERAMIC 250V 0.01uF $\Delta$
C909-912	CE51003440	CAP, ELEC. DC050HP3103
C913-916	CP61008321	CAP, M.P. 100V 104K
D901, 902	DD10000147	DIODE KBPC802 $\Delta$
D903	DD20000028	DIODE RD-20E
TX101114 PCB ASSEMBLY		
F901, 902	FU25000028	125V 4A UL/CSA $\Delta$
	FU230000190	250V T4A S $\Delta$
TB-128A PCB ASSEMBLY		
S001	SH40000155	POWER SW C-4176A01 $\Delta$
C001	CK00000035	SPARK KILLER DE7150F472M $\Delta$

SYMBOL	PARTS NO.	DESCRIPTION
OTHERS		
AB00000584		PAINTED BOTTOM BOARD 4TTF-10#2
AF20000179		FRONT CHASSIS 2TTF-2B
AM00001938		PAINTED CHASSIS BODY 2TTF-4B#2
AR20000590		PRINTED REAR CHASSIS TRP-582
DD40000095		LED LN224R
PT28407107		POWER TRANSFORMER TT-284GF $\Delta$
BC00000222		CYLINDER BUSH 4TVL-7#3 12MM
FT00000229		PLASTIC FOOT 4TSH-19#2 50Fx14H
FT00000230		PU FOOT 4TR-2823 24Fx14H
SP10006351		PT SUPPORT 3TQH-2
NP00001949		NAME STICKER AC120V 4TR-2828#1 TNP-382
NP00001974		NAME STICKER AC120V-C 4TR-2828#4 TNP-385
NP00001962		NAME STICKER AC240V 4TR-2828#3 TNP-384
NP00001950		NAME STICKER AC220V 4TR-2828#2 TNP-383
NP00001998		NAME STICKER AC230V 4TR-2828#5 TNP-389
NP00002012		NAME STICKER AC100V 4TR-2828#6 TNP-391
CD00000218		AC CORD SPT-2 AWG#18 4TR-670#4 (C, U, A) $\Delta$
CD00000292		AC POWER CORD UP-401F 4TR-2631#1 (D) $\Delta$
CD00000048		AC POWER CORD 4TR-1037 (H, E, K2) $\Delta$
CD00000085		AC POWER CORD C-2504A (K1) $\Delta$
CD00000115		AC POWER CORD C-3763-T (G) $\Delta$
SC00000131		AC CORD STOPPER SR-5N-4 (K1) $\Delta$
SC00000039		AC CORD STOPPER SR-6W-1 (D) $\Delta$
SC00000027		AC CORD STOPPER SR-4N-4 $\Delta$
AH20000448		HEAT SINKER BOARD 4TTF-7
AA20000634		FRONT PANEL 2TQH-1 TFP-621
BU00001145		POWER RING W/LED 4TQF-13 14x14
KB20002681		POWER BUTTON 4TQF-15 14x14
OM10001272		ORNAMENTAL SIDE BOARD 4TR-2797#2 H=80MM
OM70000065		PUSH BUTTON CONNECTOR 4TTL-15
SN00000179		BUTTON SPRING 4TR-1988#2 10F
SRO0000870		ORNAMENTAL PLATE SPACER 4TR-2411
AU00001201		TOP COVER POLY 3TTF-5#7 H=80MM
SRO0000882		UPPER COVER SPACER 4TR-2418
MN10002781		OWNER'S MANUAL RB-960BX
PLO0001051		STYROL SIDE MOULDING 2TR-2800 TZ-183
AZ00001597		REAR CHASSIS 2TTF-3
AZ00002851		CHASSIS BODY 2TT-4B#1
AZ00002863		BOTTOM BOARD 4TTF-10#1