

GRBL LASER CNC Controller Manual V1.1

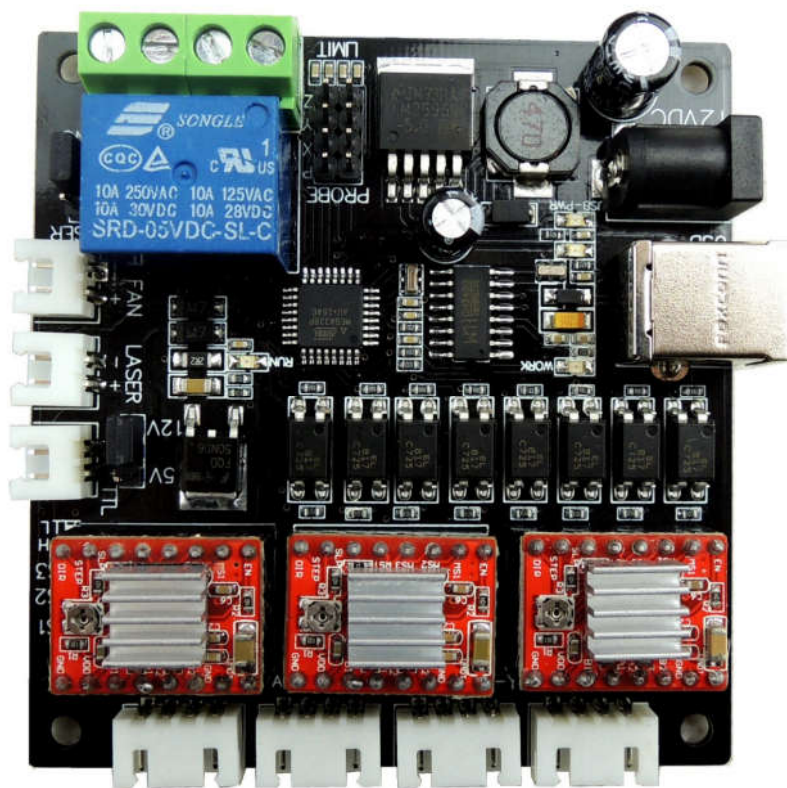

The motion control card for machine control, with strong professional. Requires the operator to have the relevant expertise! When using a laser, you need to be protected against laser damage to your eyes. Before using the tool for engraving, familiar with the software operation, be careful to operate to prevent accidents.

Contents

| | |
|---|---|
| Contents..... | 2 |
| Features: | 3 |
| Basic connection diagram (an Overview):..... | 4 |
| Mechanical dimensions diagram:..... | 5 |
| CNC LASER Control mode selection: | 6 |
| Laser interface output voltage selection : | 6 |
| Driver microstep Selection: | 6 |
| Spindle motor wiring diagram: | 7 |
| Probe, limit switch wiring:..... | 8 |
| How to control relay and laser work..... | 8 |
| A4988 driver board, the output current adjustment method: | 8 |

Features:

1. Application: use for DIY mini Engraving machine or Toy laser engraving machine
2. Applicable software: GRBL control、Un Gcode Sender、 GRBL controller.
3. Communication:USB (USB-CH340) .
4. Power supply: voltage: 12V current about 4A , according to the load to increase or decrease the power supply.
5. Stepper motor driver: A4988 motor driver,16 microstep 1.5A phase current output
6. Support stepper motor: NEMA17 NEMA23 stepper motor, phase current less than 1.5A .
7. Laser interface: 12V or 5V, power less than 18W laser module.
8. Spindle motor interface: the maximum support 400W DC spindle motor.
9. With fan interface and TTL signal output interface (for controlling the laser module with TTL module).
10. Limit interface: 3-axis limit interface.
11. Probe interface: for Z axis tool zero.
- 12.Power interface: DC-005 2.0 interface

Basic connection diagram (an Overview):

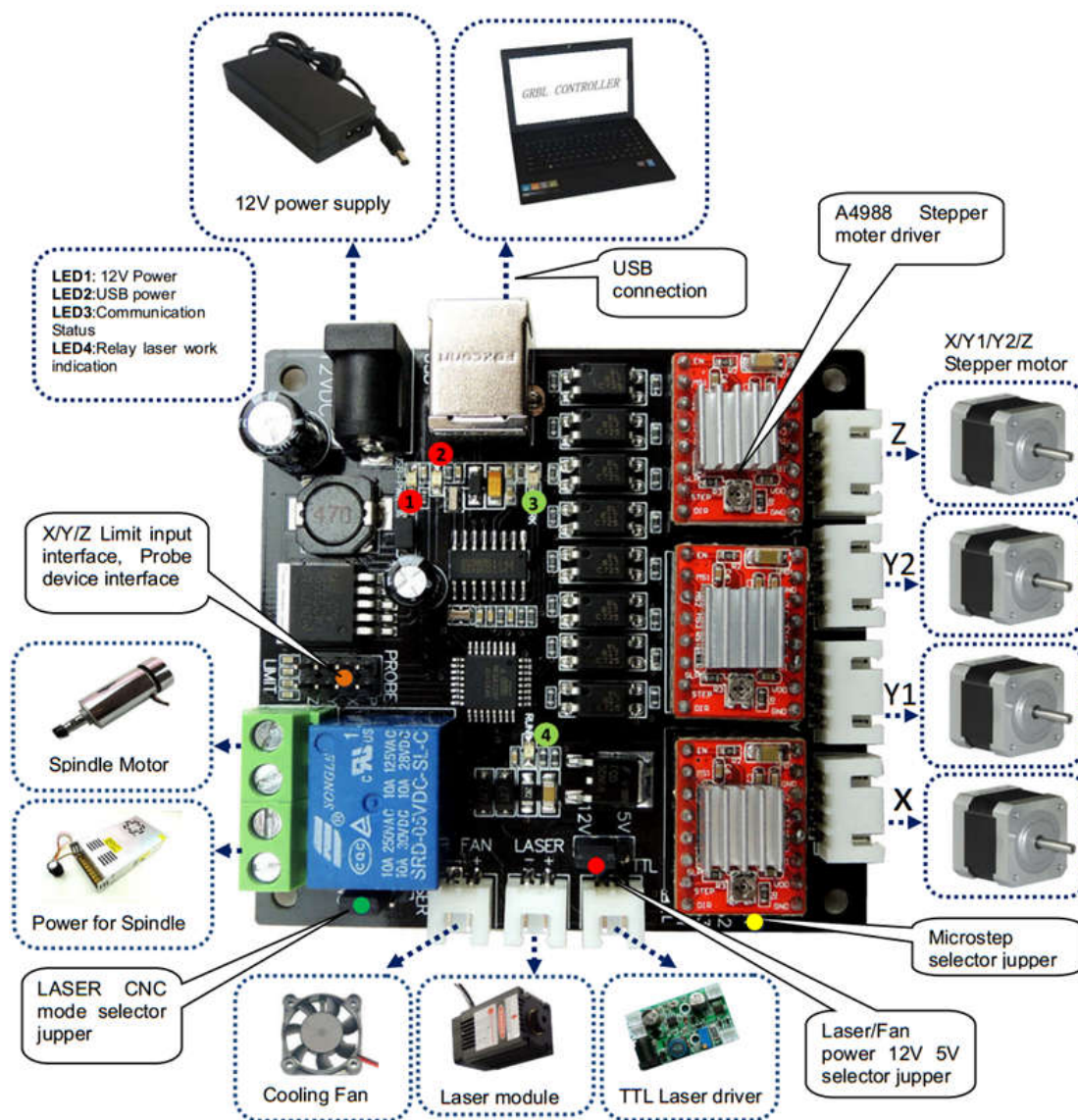

Mechanical dimensions diagram:

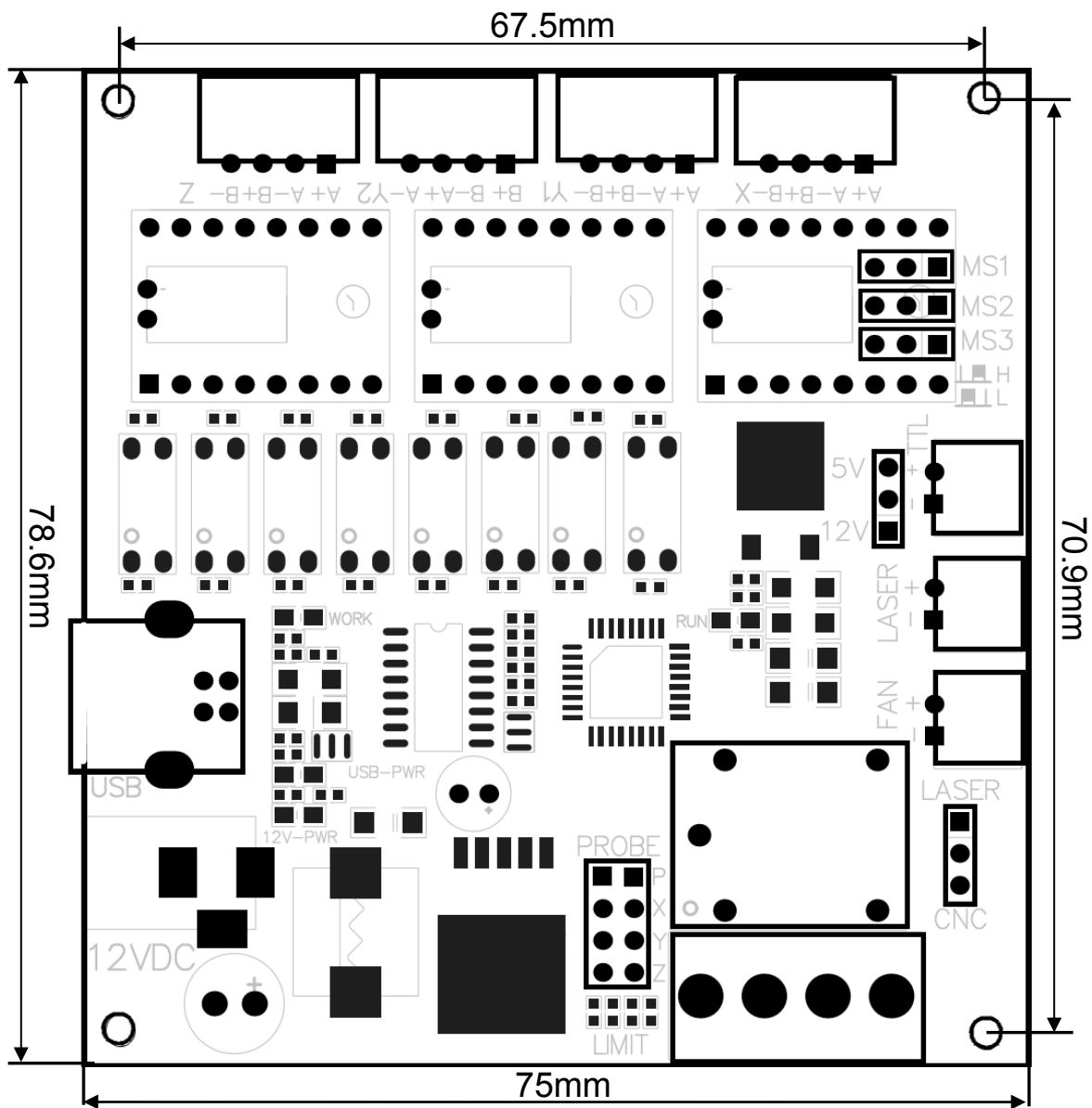

CNC LASER Control mode selection:

Controller has a selector jumper, select the **CNC mode**, Controller control relay work, select **LASER mode**, Controller control the laser interface, fan interface output. As shown below:

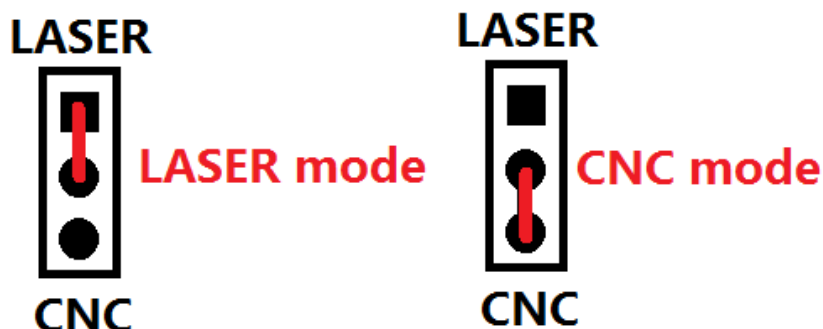

Laser interface output voltage selection :













DIY commonly used laser module supply voltage 12V and 5V, Controller provides two kinds of voltage options, according to the need to choose, as shown below:



Driver microstep Selection:

Microstep selector jumper under the X-axis driver board, remove the driver board to select microstep, the factory default for 16 microstep. The Jumper location and microstep table are as follows::

| Jumper location | Microstep |
|---|-----------|
| <div style="display: flex; justify-content: space-around; font-weight: bold; font-size: small;"> L H </div> | 16 |

| | |
|---|---|
| <div style="display: flex; justify-content: space-around; font-size: small;"> L H </div>  MS1  MS2  MS3 | 8 |
| <div style="display: flex; justify-content: space-around; font-size: small;"> L H </div>  MS1  MS2  MS3 | 4 |
| <div style="display: flex; justify-content: space-around; font-size: small;"> L H </div>  MS1  MS2  MS3 | 2 |
| <div style="display: flex; justify-content: space-around; font-size: small;"> L H </div>  MS1  MS2  MS3 | 1 |

Spindle motor wiring diagram:

Use the relay on the controller to control the spindle to start and stop, the maximum can be connected 400W DC Motor wiring as shown below:

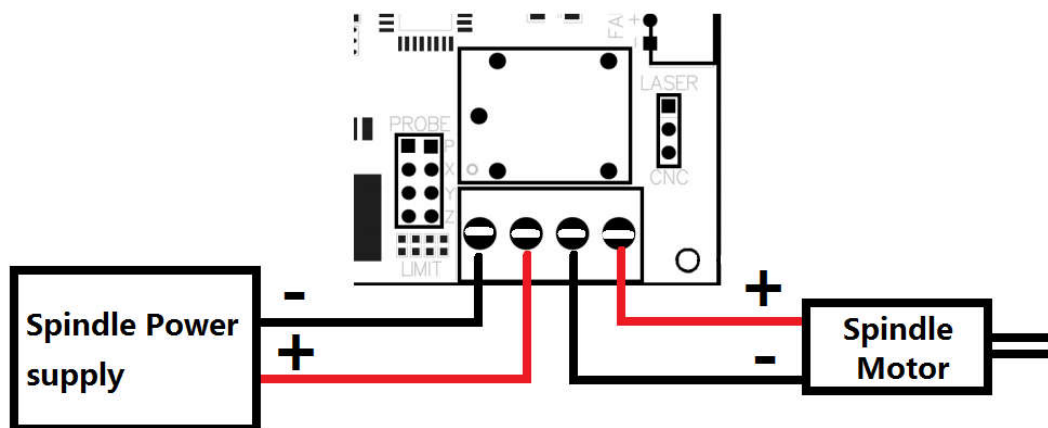

Probe, limit switch wiring:

1> At the command line, enter: \$ 21 = 1, start the limit function, limit wiring as shown below:

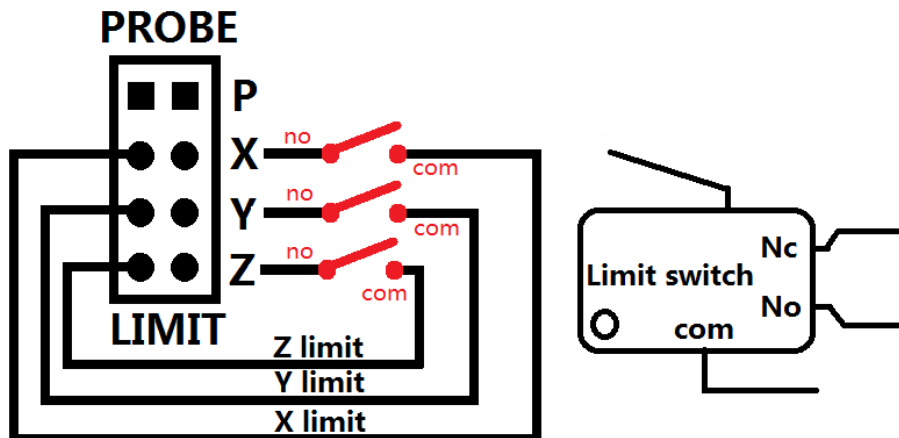

2> Input probe code: G38.2 Z-20 F3, Z axis start probe, the probe device wiring as follows:

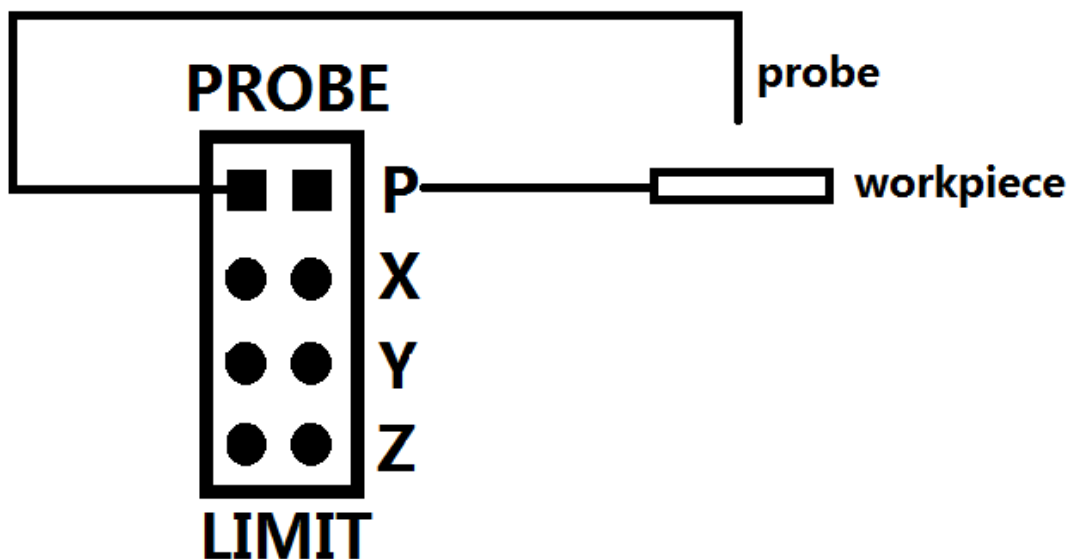

How to control relay and laser work

Code **M3** controls the relay and laser output, **M5** turns off the relay and laser, and can also be realized by operating the buttons on the software.

A4988 driver board, the output current adjustment method:

Clockwise rotation of the potentiometer on the drive board, the output current increases, counterclockwise rotation potentiometer, the current decreases. Measure the voltage between the potentiometer and GND, calculate the specific current value, as shown below:

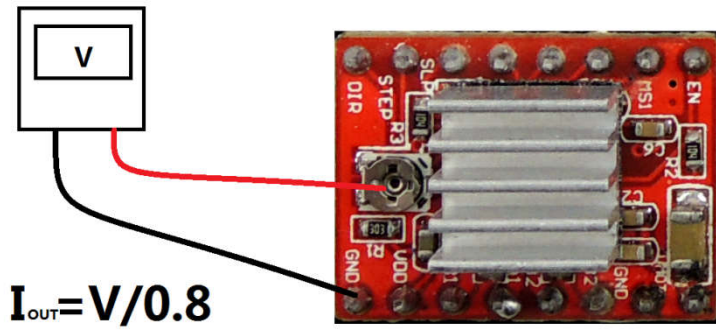

$$I_{\text{OUT}} = V/0.8$$

Output phase current: $I = V/0.8$