

AKAI STEREO TAPE DECK

MODEL **GX-4000D/DB**

ALSO APPLICABLE TO BLACK PANEL MODEL

SECTION 1	SERVICE MANUAL	3
SECTION 2	PARTS LIST	33
SECTION 3	SCHEMATIC DIAGRAM	59

SECTION I

SERVICE MANUAL

TABLE OF CONTENTS

I.	TECHNICAL DATA	4
	1. MODEL GX-4000D	4
	2. MODEL GX-4000DB	5
II.	DISMANTLING OF UNIT	6
III.	CONTROLS	8
IV.	PRINCIPAL PARTS LOCATION	10
V.	MECHANISM ADJUSTMENT	11
	1. PINCH ROLLER PRESSURE MEASUREMENT	11
	2. REEL TABLE BLOCK ADJUSTMENT	11
	3. DRIVE BELT POSITION ADJUSTMENT	13
	4. FLYWHEEL LOOSE PLAY ADJUSTMENT	13
	5. AUTOMATIC SHUT-OFF OPERATING POINT ADJUSTMENT	13
VI.	HEAD ADJUSTMENT	14
	1. HEAD HEIGHT ADJUSTMENT	14
	2. HEAD AZIMUTH ALIGNMENT ADJUSTMENT	14
	3. HEAD ANGLE ALIGNMENT ADJUSTMENT	15
VII.	AMPLIFIER ADJUSTMENT	16
	1. MODEL GX-4000D	16
	2. MODEL GX-4000DB	18
VIII.	DC RESISTANCE OF VARIOUS COILS	20
IX.	CLASSIFICATION OF VARIOUS P.C BOARDS	20
	1. P.C BOARD TITLE AND IDENTIFICATION NUMBER	20
	2. MODEL GX-4000D COMPOSITION OF VARIOUS P.C BOARDS	21
	3. MODEL GX-4000DB COMPOSITION OF VARIOUS P.C BOARDS	26

For basic adjustments, measuring methods, and operating principles, refer to GENERAL TECHNICAL MANUAL.

I. TECHNICAL DATA

1. MODEL GX-4000D

TRACK SYSTEM	4 track, 2 channel stereo/monaural system
REEL CAPACITY	Up to 7" reel
TAPE SPEED	7-1/2 and 3-3/4 ips
WOW & FLUTTER	Less than 0.08% WRMS
FREQUENCY RESPONSE	30 to 24,000 Hz ± 3 dB at 7-1/2 ips 30 to 16,000 Hz ± 3 dB at 3-3/4 ips
DISTORTION (1,000 Hz "0" VU)	Less than 1.0% at 7-1/2 ips
SIGNAL TO NOISE RATIO	Better than 60 dB (measured via tape with peak recording level)
ERASE RATIO	Better than 70 dB
BIAS FREQUENCY	100 kHz
HEADS	(3): One GX Recording head, one GX Playback head, one Erase head
MOTOR	(1): 4-pole induction motor
FF & REWIND TIME	200 sec using 1,200 ft. tape
OUTPUT JACKS	Line (2): 0.775V ("0" VU) Required load impedance: more than 50 kohms Phone (1): 100 mV/8 ohms
INPUT JACKS	Microphone (2): 0.25 mV Required microphone impedance: 600 ohms Line (2): 70 mV
DIN JACK	Input: 2 mV/10 kohms, Output: 0.3V
SEMICONDUCTORS	Transistors: 24, Diodes: 13, FETs: 2, IC: 1
DIMENSIONS	440(W) x 315(H) x 230(D) mm (17.3 x 12.4 x 9.1")
WEIGHT	13.2 kg (29.1 lbs)
POWER REQUIREMENTS	100V, 50/60 Hz for Japan 120V, 60 Hz for Canada & U.S.A. 220/240V, 50 Hz for European Countries & Australia 110/120/220/240V (Switchable), 50/60 Hz for the other Countries

* For improvement purposes, specifications and design are subject to change without notice.

2. MODEL GX-4000DB

TRACK SYSTEM	4 track, 2 channel stereo/monaural system
REEL CAPACITY	Up to 7" reel
TAPE SPEED	7-1/2 and 3-3/4 ips
WOW & FLUTTER	Less than 0.08% WRMS
FREQUENCY RESPONSE	30 to 24,000 Hz ± 3 dB at 7-1/2 ips 30 to 16,000 Hz ± 3 dB at 3-3/4 ips
DISTORTION (1,000 Hz "0" VU)	Less than 1.0% at 7-1/2 ips
SIGNAL TO NOISE RATIO	Better than 60 dB (measured via tape with peak recording level) Dolby Switch ON: Improves up to 10 dB above 5 kHz
ERASE RATIO	Better than 70 dB
BIAS FREQUENCY	100 kHz
HEADS	(3): One GX Recording head, one GX Playback head one Erase head
MOTOR	(1): 4-pole induction motor
FF & REWIND TIME	200 sec using 1,200 ft tape
OUTPUT JACKS	Line (2): 580 mV ("0" VU) Required load impedance: more than 100 kohms Phone (1): 100 mV/8 ohms
INPUT JACKS	Microphone (2): 0.25 mV Required microphone impedance: 600 ohms Line (2): 70 mV
DIN JACKS	Input: 2 mV/10 kohms Output: 0.3V
SEMICONDUCTORS	Transistors: 21, Diodes: 21, FETs: 2, ICs: 5
DIMENSION	440(W) x 315(H) x 230(D) mm (17.3 x 12.4 x 9.1")
WEIGHT	13.2 kg (29.1 lbs)
POWER REQUIREMENT	120V, 60 Hz for Canada & U.S.A. 220/240V, 50 Hz for European Countries & Australia 110/120/220/240V (Switchable), 50/60 Hz for the other Countries

* For improvement purposes, specifications and design are subject to change without notice.

* "Dolby" and the Double D symbol are trademarks of Dolby Laboratories.

(Manufactured under license from Dolby Laboratories.)

II. DISMANTLING OF UNIT

In case of trouble, etc. necessitating dismantling, please dismantle in the order shown in the photographs. Reassemble in reverse order.

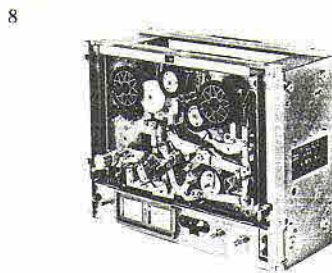
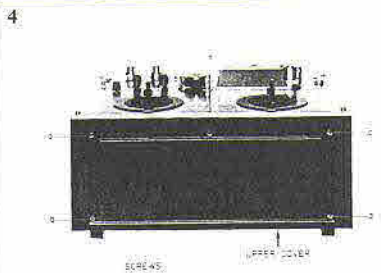
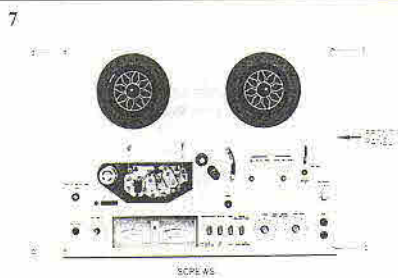
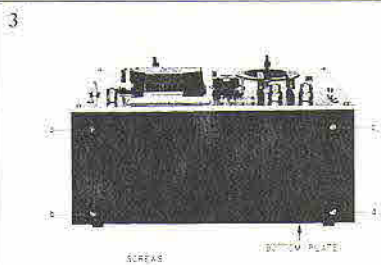
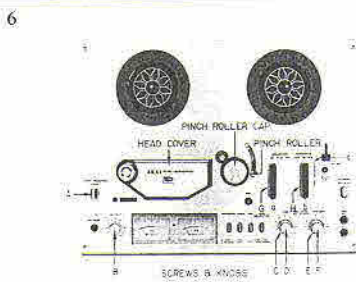
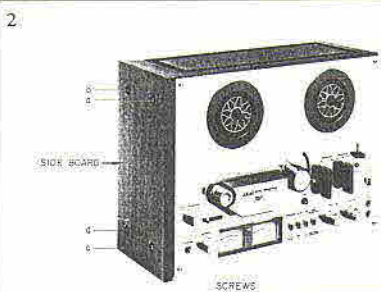
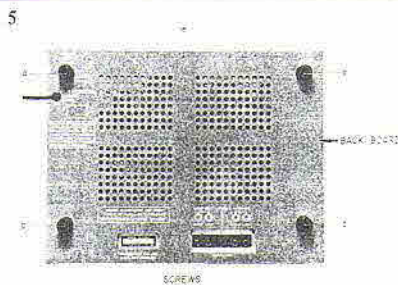
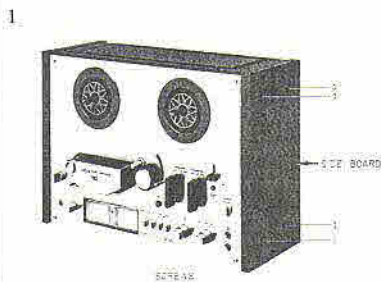

III. CONTROLS

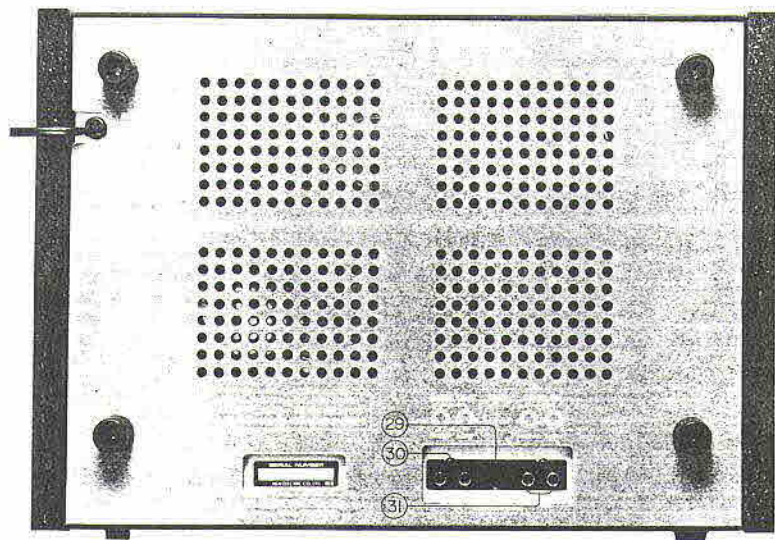
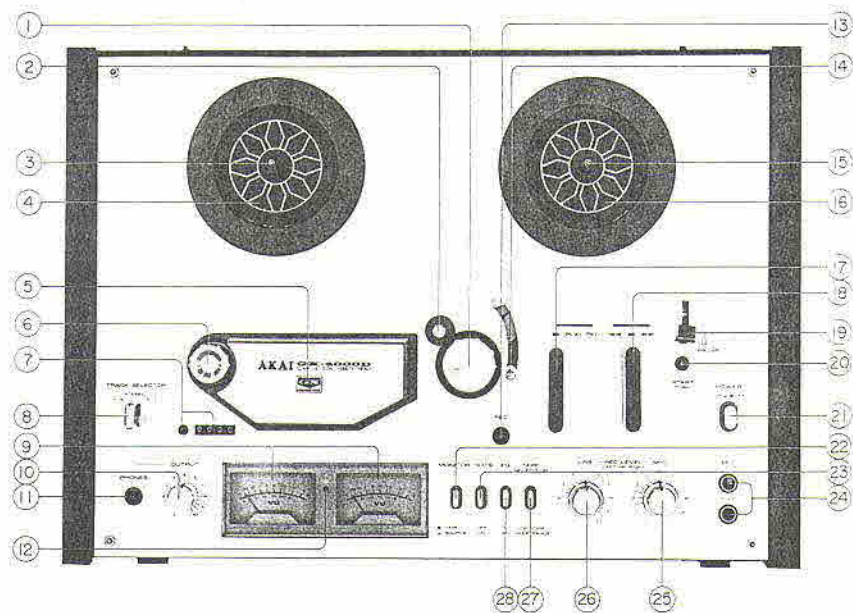

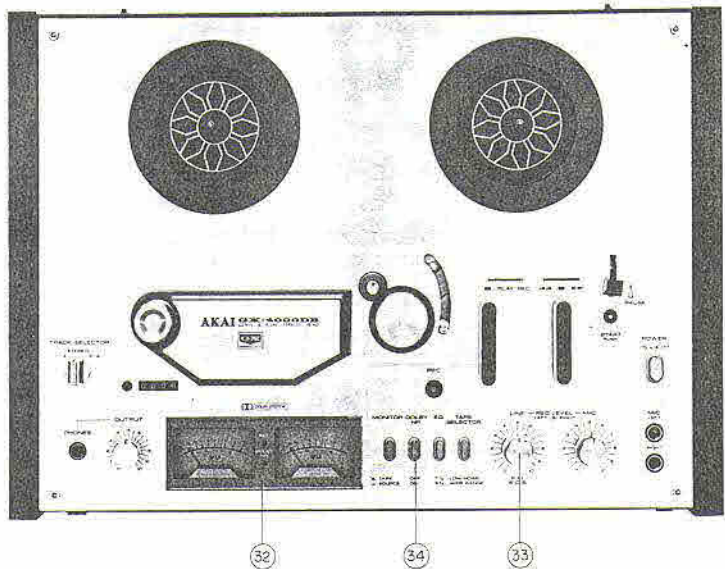

Fig. 1 Controls

- | | |
|---------------------------------|---|
| 1. PINCH ROLLER | 18. FAST FORWARD/REWIND LEVER |
| 2. CAPSTAN | 19. PAUSE LEVER |
| 3. REEL RETAINER (Left) | 20. START BUTTON |
| 4. SUPPLY REEL TABLE | 21. POWER |
| 5. HEAD COVER | 22. MONITOR SELECTOR SWITCH (Tape & Source) |
| 6. TAPE GUIDE | 23. S.O.S. (Sound-On-Sound) BUTTON |
| 7. INDEX COUNTER & RESET BUTTON | 24. MICROPHONE JACKS (Left & Right) |
| 8. TRACK SELECTOR | 25. MICROPHONE RECORDING LEVEL CONTROLS |
| 9. VU METERS (Left & Right) | 26. LINE RECORDING LEVEL CONTROLS |
| 10. OUTPUT VOLUME | 27. TAPE SELECTOR SWITCH |
| 11. HEADPHONE JACK | 28. EQUALIZER SWITCH |
| 12. RECORDING INDICATOR LAMP | 29. DIN JACK |
| 13. RECORDING SAFETY BUTTON | 30. LINE OUTPUT JACKS (Left & Right) |
| 14. AUTOMATIC STOP LEVER | 31. LINE INPUT JACKS (Left & Right) |
| 15. REEL RETAINER (Right) | 32. DOLBY N.R. INDICATOR LAMP |
| 16. TAKE-UP REEL TABLE | 33. S.O.S. SWITCH/LINE RECORDING LEVEL CONTROLS |
| 17. RECORDING/PLAYBACK LEVER | 34. DOLBY N.R. SWITCH |

IV. PRINCIPAL PARTS LOCATION

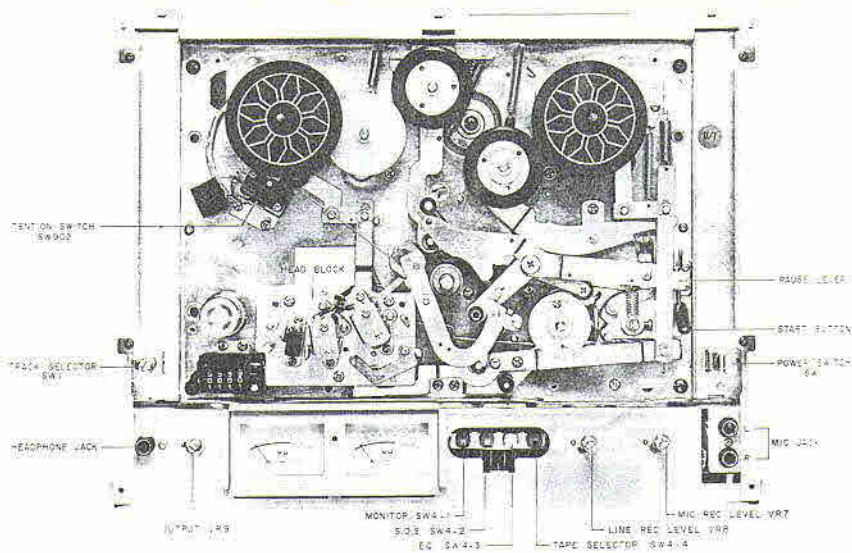

Fig. 2 Front View (GX-4000D)

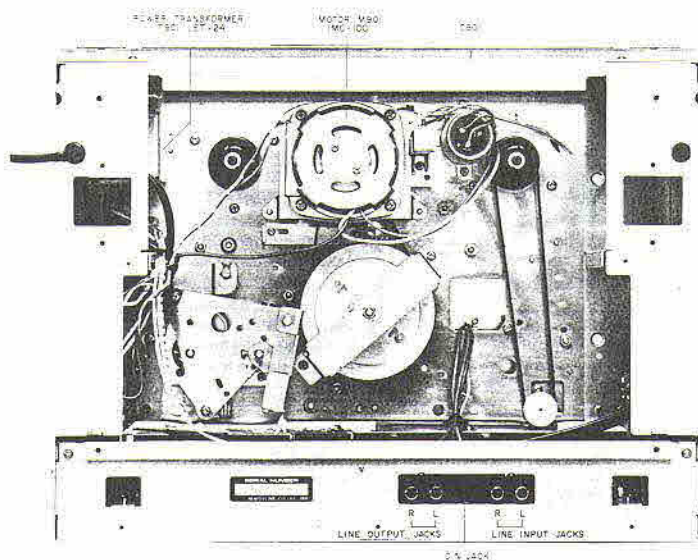

Fig. 3 Rear View (GX-4000D)

V. MECHANISM ADJUSTMENT

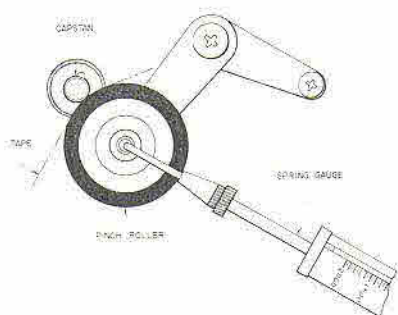

Fig. 4 Pinch Roller Pressure Measurement

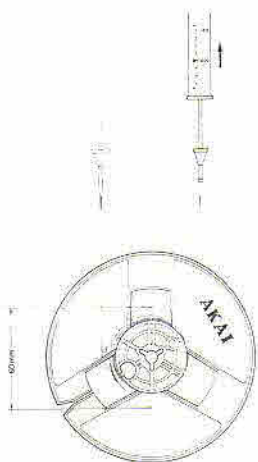

Fig. 5

1. PINCH ROLLER PRESSURE

MEASUREMENT (Refer to Fig. 4)

Set the recorder in the PLAY Mode. Pull the pinch roller 1~2 mm away from the capstan with the spring gauge as shown in Fig. 4. Slowly release and take the spring gauge reading when the pinch roller touches the capstan and begins to rotate. The specified pinch roller pressure is 1150~1200g. (Tape speed: 7.5 ips)

2. REEL TABLE BLOCK ADJUSTMENT

(Refer to Figs. 5, 6)

* Necessary points when measuring the tension

Wind the tape onto a 5" empty reel until there is a diameter of 60 mm of tape. (See Fig. 5). Make the end of the tape into a loop and put onto the spring gauge.

A. SUPPLY REEL TABLE BLOCK ADJUSTMENT

1) RWD Tension Adjustment

A spring gauge reading of 400~500g in the RWD Mode.

To adjust, increase or decrease the number of (1) washers.

2) PLAY Mode Back Tension Adjustment

A spring gauge reading of 100~120g in PLAY Mode.

To adjust, increase or decrease the number of (2) washers.

3) FF Free Tension Adjustment

A spring gauge reading of 15~20g in the FF Mode.

To adjust, move the position of pulley (3) backwards and forwards.

B. TAKE-UP REEL TABLE BLOCK ADJUSTMENT

1) FF Tension Adjustment

A spring gauge reading of 400~500g in the FF Mode.

To adjust, increase or decrease the number of (1) washers.

2) PLAY Tension Adjustment

A spring gauge reading of 150~180g in the PLAY Mode.

To adjust, increase or decrease the number of (2) washers.

3) RWD Free Tension Adjustment

A spring gauge reading of 15~20g in the RWD Mode.

To adjust, move the position of pulley (3) backwards and forwards.

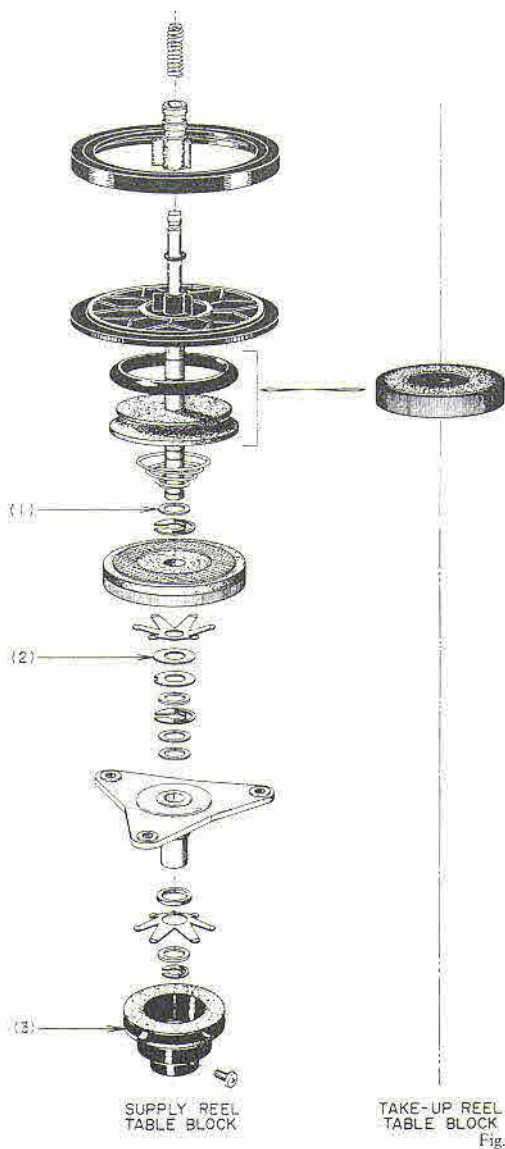

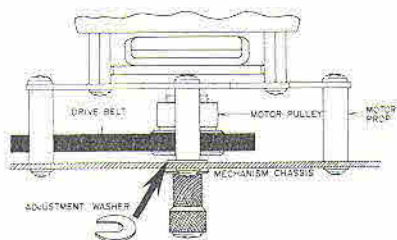

Fig. 7

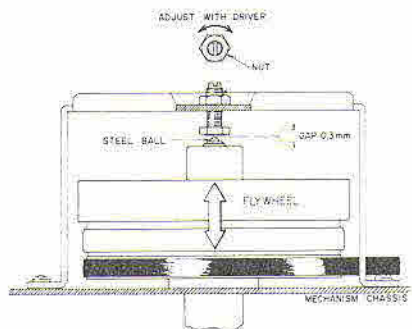

Fig. 8

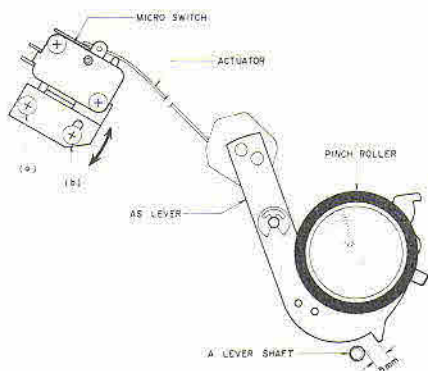

Fig. 9

3. DRIVE BELT POSITION ADJUSTMENT

(Refer to Fig. 7)

Adjust position of drive belt so that it comes to the center of the motor pulley by inserting a washer (or washers) between the motor prop and mechanism chassis as shown in Fig. 12.

4. FLYWHEEL LOOSE PLAY ADJUSTMENT

(Refer to Fig. 8)

With a minus screw driver, turn bearing to left and right and adjust so that when the flywheel is moved as indicated by the arrow mark in the figure, the gap between the steel ball and flywheel supporting plate is 0.3 mm as shown in Fig. 8. Fix at this position with nut.

5. AUTOMATIC SHUT-OFF OPERATING

POINT ADJUSTMENT (Refer to Fig. 9)

Loosen screws (a) and (b) and adjust installed position of Micro Switch so that when AS Lever is lowered as a result of the Power Switch being set to SHUT-OFF position, the gap between AS Lever is about 5 mm.

VI. HEAD ADJUSTMENT

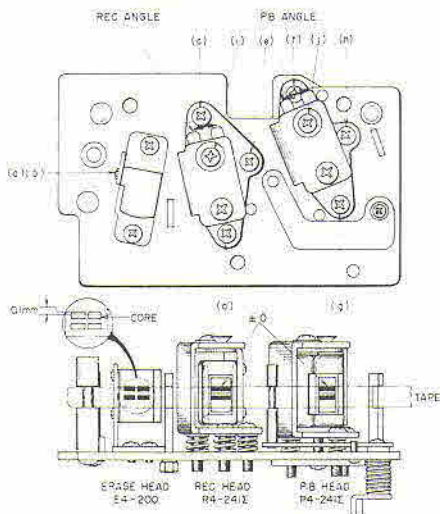

Fig. 10

1. HEAD HEIGHT ADJUSTMENT

(Refer to Fig. 10)

1) Erase Head

Loosen screws (a) and (b) shown in Fig. 10 and adjust erase head height. Tighten screws at position at which the upper edge of the tape is 0.1 mm lower than the upper edge of the left channel head core of the erase head.

2) Recording Head

Adjust head height adjustment screws (c) and (d) shown in Fig. 10 so that the upper edge of the tape and the upper edge of left channel head core of the recording head are the same height.

3) Playback Head

Adjust head height adjustment screws (f) and (g) shown in Fig. 10 so that the upper edge of the tape and the upper edge of left channel head core of the playback head are the same height.

2. HEAD AZIMUTH ALIGNMENT

ADJUSTMENT (Refer to Fig. 10)

1) Playback Head

- Connect a High Sensitivity AC Voltmeter to the left and right channel Output Terminals of the tape deck.
- Set the Track Selector to STEREO and set the machine to 7-1/2 ips tape speed.
- Playback an 8,000 Hz 3-3/4 ips alignment adjustment test tape.
- Adjust adjustment screw (h) to obtain maximum High Sensitivity AC Voltmeter indication on both channels.

2) Recording Head

- Connect an Audio Frequency Oscillator to the line input through an Attenuator, and connect a High Sensitivity AC Voltmeter to the line output. Then load a blank test tape.
- Set the Monitor Switch to SOURCE and supply a 16,000 Hz sine wave signal. Adjust the Attenuator or the Line Recording Level Controls to obtain a -20 dBm High Sensitivity AC Voltmeter indication.
- Reset Monitor Switch to TAPE and set deck to recording mode.
- Adjust adjustment screw (e) to obtain maximum High Sensitivity AC Voltmeter indication on both channels.

3. HEAD ANGLE ALIGNMENT

ADJUSTMENT (Refer to Fig. 10)

1) Playback Head

- a. Connect a High Sensitivity AC Voltmeter to the left and right channel Output Terminals of the tape deck.
- b. Set the Track Selector to STEREO and set the machine to 7-1/2 ips tape speed.
- c. Playback an 8,000 Hz 3-3/4 ips alignment adjustment test tape.
- d. Loosen screw (j). Adjust PB angle in the direction of the arrow and change the angle of the head-to-tape contact.

Fix the PB head at a position where the output level is not effected by an additional tension to the supply reel.

(e.g. slightly touching the supply reel).

2) Recording Head

- a. Connect an Audio Frequency Oscillator to the line input through an Attenuator, and connect a High Sensitivity AC Voltmeter to the line output. Then load a blank test tape.
- b. Set the Monitor Switch to SOURCE and supply a 16,000 Hz sine wave signal. Adjust the Attenuator or the Line Recording Level Controls to obtain a -20 dBm High Sensitivity AC Voltmeter indication.
- c. Reset Monitor Switch to TAPE and set deck to recording mode.
- d. Loosen screw (i). Adjust REC angle in the direction of the arrow and change the angle of the head-to-tape contact.

Fix the REC head at a position where the output level is not effected an additional tension to the supply reel.

(e.g. slightly touching the supply reel).

NOTES: 1. As head adjustment greatly affects tape deck performance, be sure that these adjustments are carried out properly.

2. Be careful not to use magnetized tools near the heads.

3. As the level of old tape varies greatly, use new tape.

4. Demagnetize heads before and after head adjustment.

Step	Adjustment Item	Test Tape Supply Signal	Mode	Adjustment Point	Result	Remarks
5	Distortion Factor Confirmation	1,000 Hz 0 VU recording	REC/ PLAY		Less than 1.0%	(Refer to NOTE 5)
6	PB Amp Bias Filter Adjustment	100 kHz from an oscillator	REC	VL1 23 mH(L) VL2 23 mH(R)	Minimum AC Voltmeter indication	Set Monitor Switch to "TAPE". (Refer to NOTES 6, 7)
7	REC Amp Bias Filter Adjustment	100 kHz from an oscillator	REC	VL3 23 mH(L) VL4 23 mH(R)	Minimum AC Voltmeter indication	Set Monitor Switch to to "SOURCE". (Refer to NOTES 6, 7)

Chart-1

- NOTES:**
1. Output Level Control should be at maximum.
 2. Except for Step 3, set tape speed to 7 1/2 ips.
 3. Set tape selector to Low Noise position.
 4. (L) = Left Channel, (R) = Right Channel.
 5. If it does not comply with the specifications, repeat Steps 3, 4 and re-adjust.
 6. Unless the core is moved intentionally this adjustment is not necessary.
 7. Adjust the oscillator's frequency to give a frequency counter reading of 100 kHz.

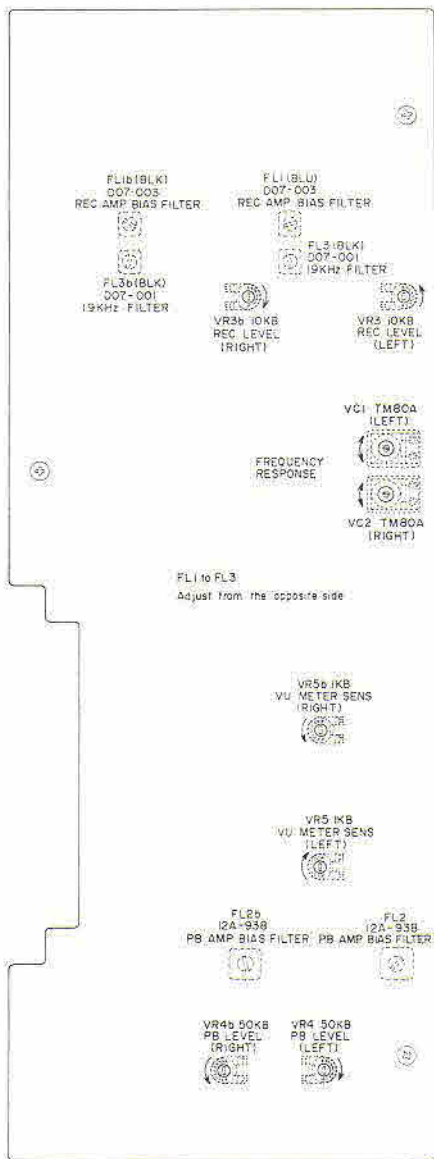

Fig. 13 Amp P.C Board LE-5701A (GX-4000DB)

Step	Adjustment Item	Test Tape Supply Signal	Mode	Adjustment Point	Result	Remarks
1	Playback Level Adjustment	700 Hz. 7-1/2 ips Test Tape	PLAY	VR4 50 k Ω	-2.5 dBm \pm 0.5 dBm (580 mV)	Set Monitor Switch to "TAPE".
2	VU Meter Sensitivity Adjustment	700 Hz. 7-1/2 ips Test Tape	PLAY	VR5 1 k Ω	0 VU indication	
3	Frequency Response Adjustment	SCOTCH #211 tape 1,000 Hz 10,000 Hz, -20 VU recording	REC/ PLAY	VC1 80P(L) VC2 80P(R)	Adjust to +1 dB at 10,000 Hz in relation to 1,000 Hz	Tape Speed to 3-3/4 ips. Set EQ Switch to "3-3/4".
4	Recording Level Adjustment	1,000 Hz 0 VU from an oscillator	STOP	REC Volume (VR2 50k Ω)	-2.5 dBm \pm 0.5 dBm (580 mV)	Set Monitor Switch to "SOURCE".
		SCOTCH #211 tape 1,000 Hz 0 VU Recording	REC/ PLAY	VR3 10 k Ω	-2.5 dBm \pm 0.5 dBm (580 mV)	Set Monitor Switch to "TAPE".
5	Distortion Factor Confirmation	1,000 Hz 0 VU recording	REC/ PLAY		Less than 1.0%	
6	PB Amp Bias Filter Adjustment	100 kHz from an oscillator	REC	FL2 12A-938	Minimum AC Voltmeter indication	Set Monitor Switch to "TAPE". (Refer to NOTES 6, 7)
7	REC Amp Bias Filter Adjustment	100 kHz from an oscillator	REC	FL1 D07-003	Minimum AC Voltmeter indication	Set Monitor Switch to "SOURCE". (Refer to NOTES 6, 7)
8	19 kHz Filter Adjustment	19 kHz from an oscillator	STOP	FL3 D07-001	Minimum AC Voltmeter indication	DOLBY N.R. Switch to ON. (Refer to NOTE 8)

Chart-2

- NOTES:**
- Output Level Control should be at maximum.
 - Except for Step 3, set tape speed to 7-1/2 ips.
 - Set tape selector to Low Noise position.
 - (L) = Left Channel, (R) = Right Channel.
 - If it does not comply with the specifications, repeat Steps 3, 4 and re-adjust.
 - Unless the core is moved intentionally this adjustment is not necessary.
 - Adjust the oscillator's frequency to give a frequency counter reading of 100 kHz.
 - Adjust the oscillator's frequency to give a frequency counter reading of 19.00 kHz.

VIII. DC RESISTANCE OF VARIOUS COILS

Part	Designation	DC Resistance
Erase Head	E4-200	2.0 ohms
Recording Head	R4-241Σ	5.9 ohms
Playback Head	P4-241Σ	219 ohms

Chart-3

IX. CLASSIFICATION OF VARIOUS P.C BOARDS

1. P.C BOARD TITLE AND IDENTIFICATION NUMBER

1) Model GX-4000D

P.C Board Title	P.C Board Number
Amp P.C Board	LE-5801A
Power Supply P.C Board	LE-5802
SW P.C Board	LE-5801C
LED P.C Board	LE-5801B

Chart-4

2) Model GX-4000DB

P.C Board Title	P.C Board Number
Amp P.C Board	LE-5701A
Power Supply P.C Board	LE-5702
LED P.C Board	LE-5701B

Chart-5

2. MODEL GX-4000D COMPOSITION OF VARIOUS P.C BOARDS

1) AMP P.C BOARD LE-5801A(2ED), LED P.C BOARD LE-5801B(2ED) & SW. P.C BOARD LE-5801C

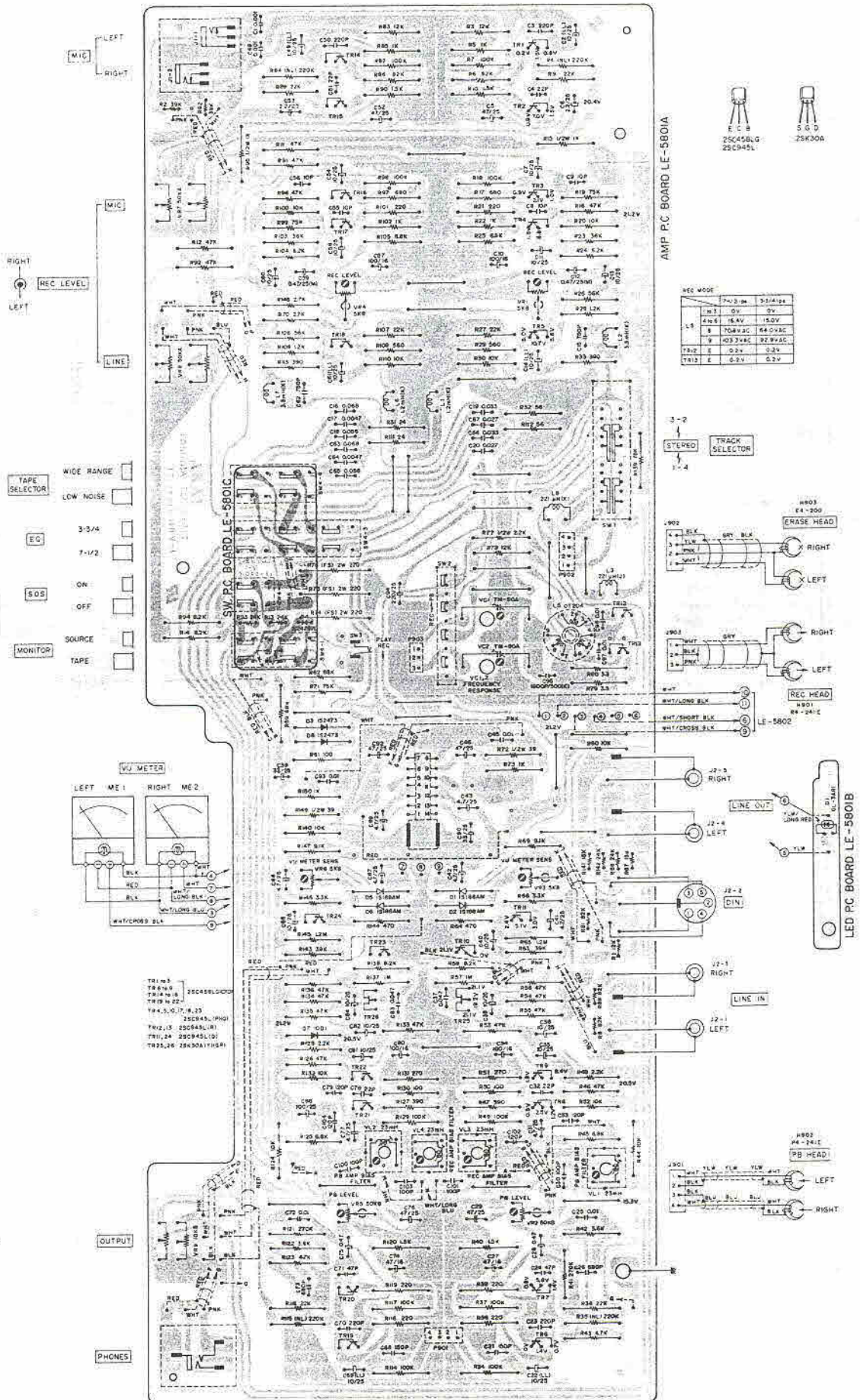

2) POWER SUPPLY P.C BOARD LE-5802 (U/T)

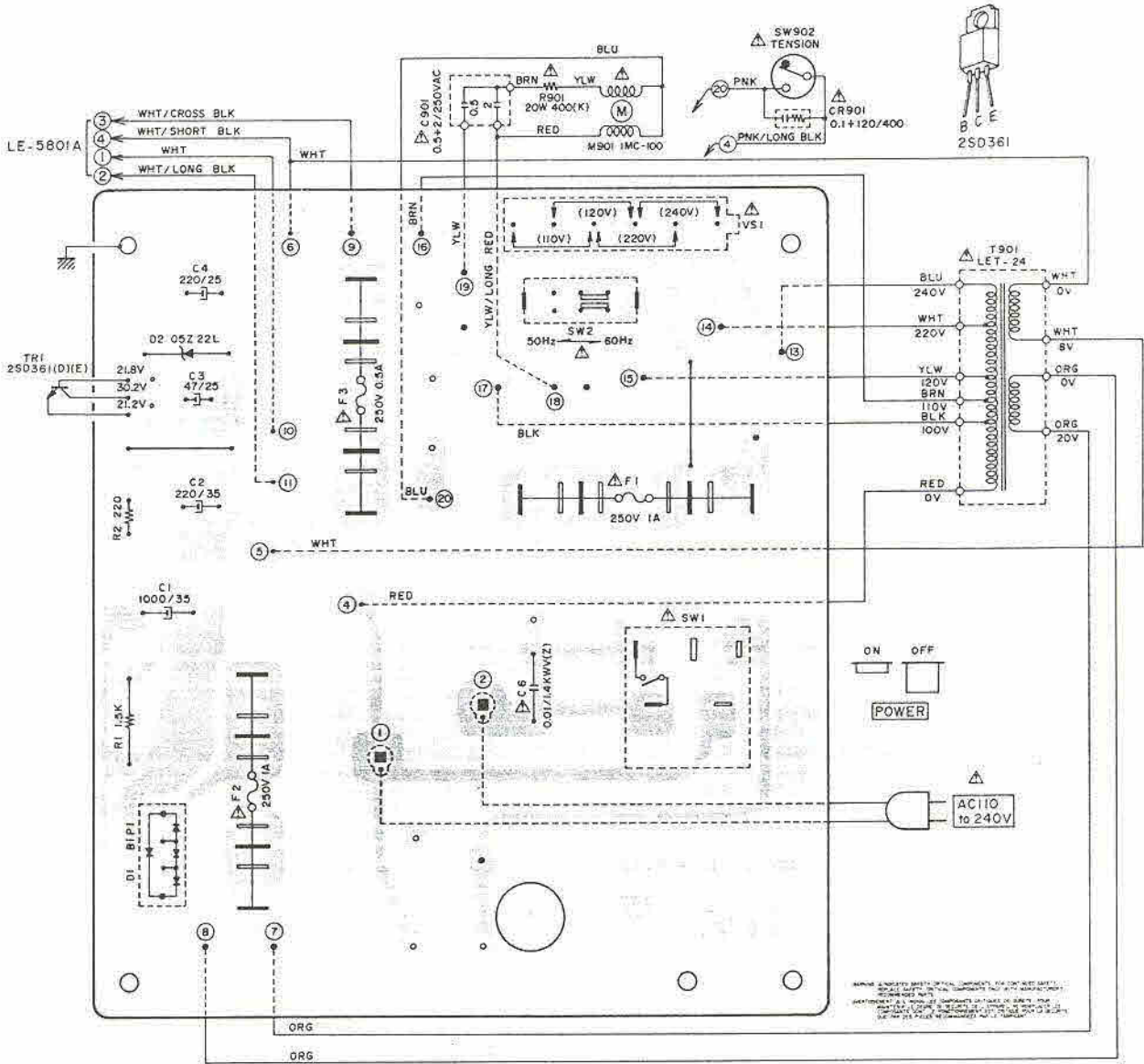

WARNING: INDICATED SAFETY SYMBOLS, COMPONENTS, OR CIRCUITS ARE NOT TO BE USED IN ANY OTHER MANNER THAN AS SPECIFIED IN THIS DOCUMENT. THE USER SHALL BE RESPONSIBLE FOR THE PROPER USE OF THE INFORMATION CONTAINED HEREIN.

3) POWER SUPPLY P.C BOARD LE-5802 (CSA, AAL)

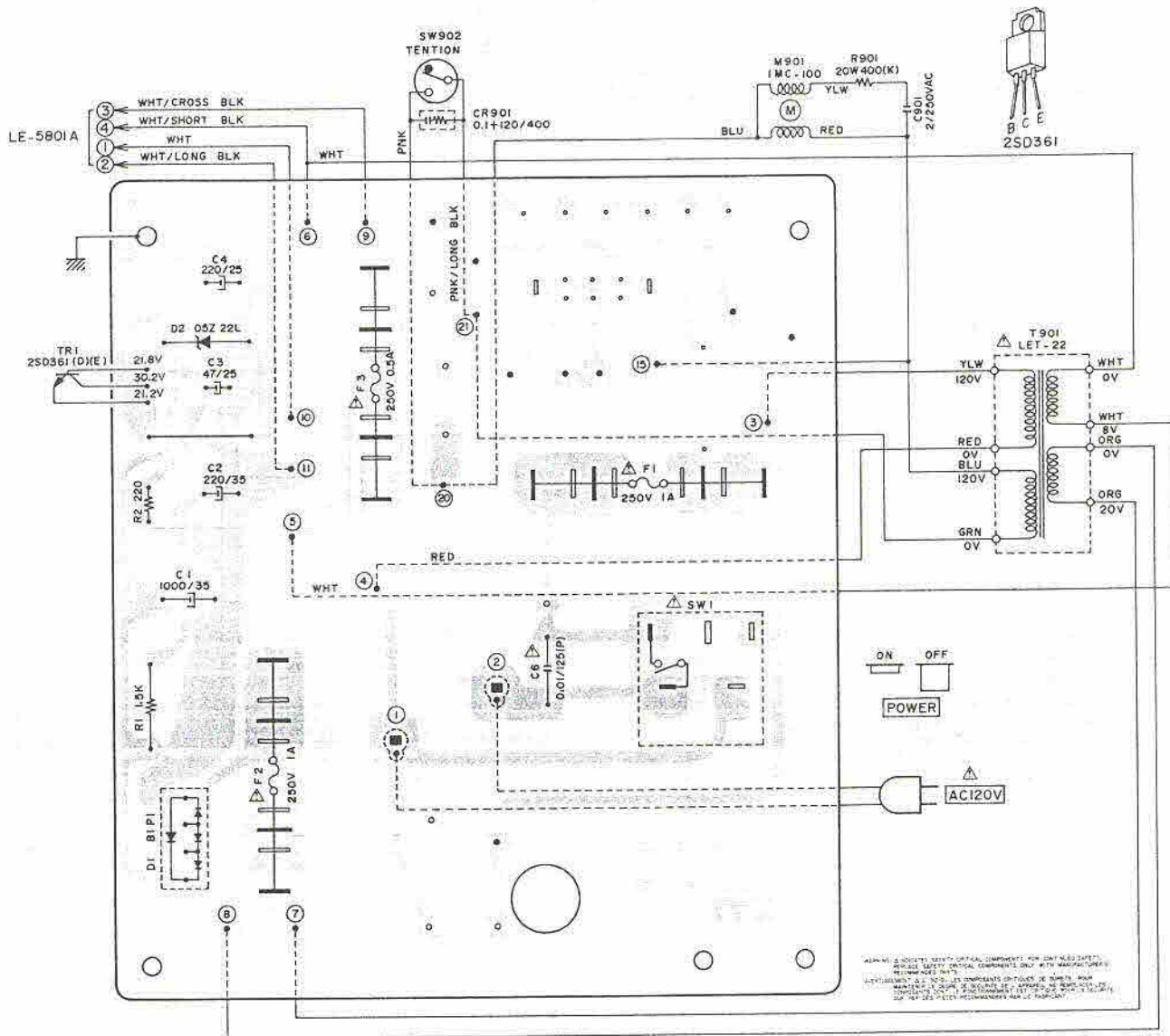

WARNING: A SOURCE OF ELECTRICAL COMPONENTS FOR THE BOARD ALSO SUPPLIES
 PLEASE SAFETY PRECAUTIONS SHOULD BE TAKEN WHEN MANIPULATING THE BOARD.
 LE-5802 (CSA, AAL) IS A TRADE SECRET OF THE MANUFACTURER.
 ALL RIGHTS RESERVED. NO PART OF THIS DOCUMENT SHOULD BE REPRODUCED OR TRANSMITTED IN ANY FORM OR BY ANY MEANS, ELECTRONIC OR MECHANICAL, INCLUDING PHOTOCOPYING, RECORDING, OR BY ANY INFORMATION STORAGE AND RETRIEVAL SYSTEM.
 © 1994 BY THE MANUFACTURER. ALL RIGHTS RESERVED.

4) POWER SUPPLY P.C BOARD LE-5802 (CEE, U.K.)

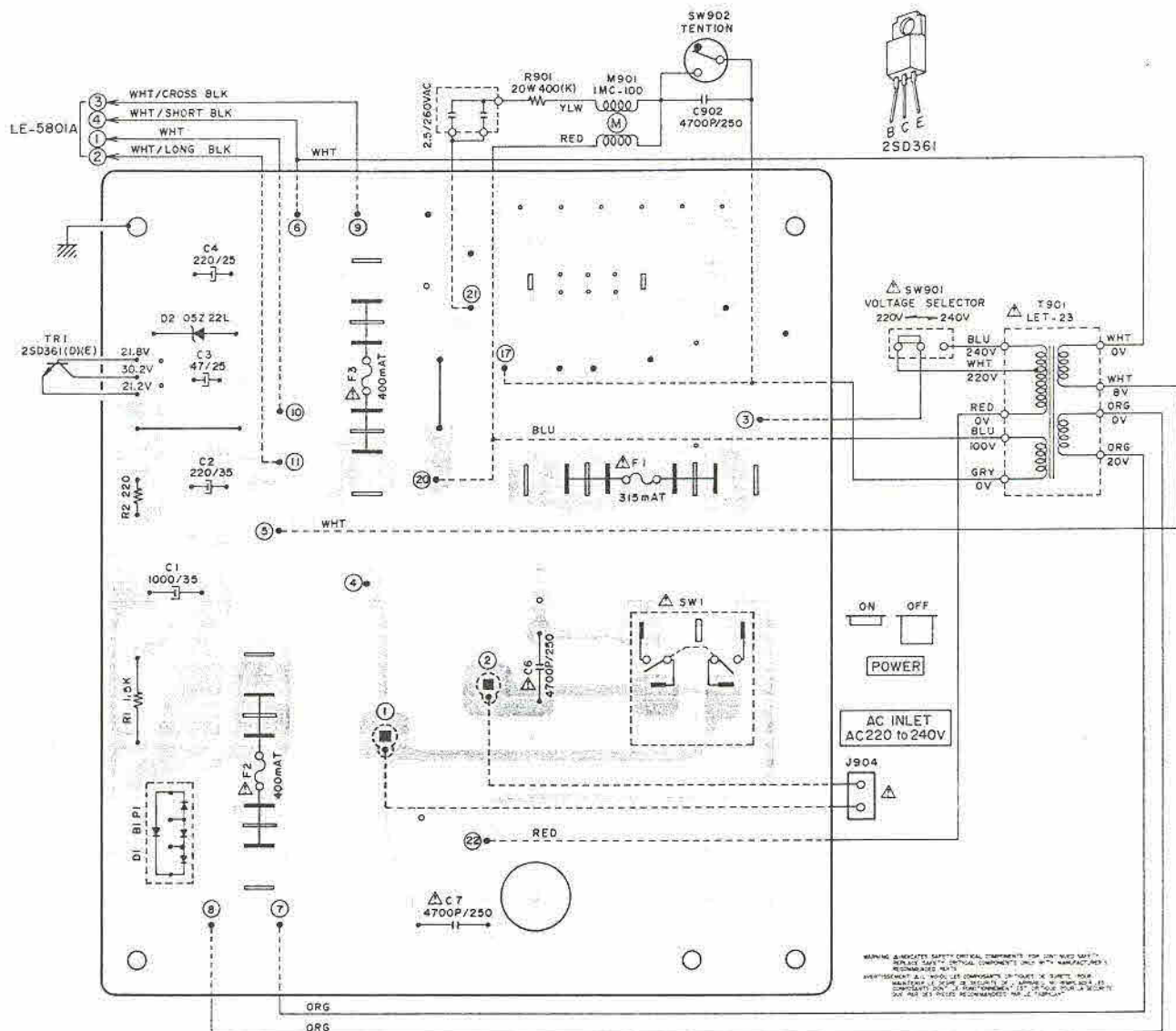

3. MODEL GX-4000DB COMPOSITION OF VARIOUS P.C BOARDS

1) AMP P.C BOARD LE-5701A(2ED) & LED P.C BOARD LE-5701B

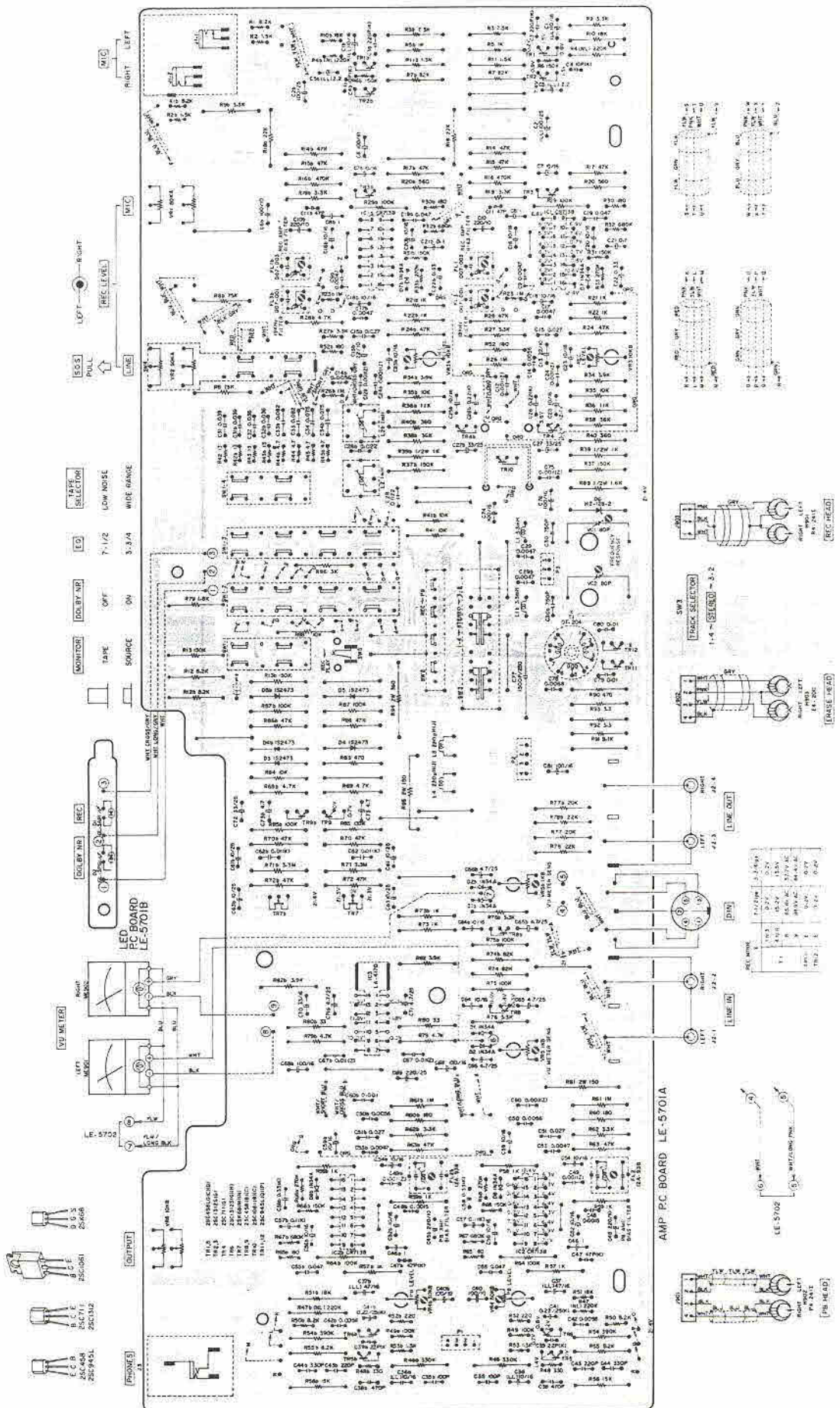

2) POWER SUPPLY P.C BOARD LE-5702 (U/T)

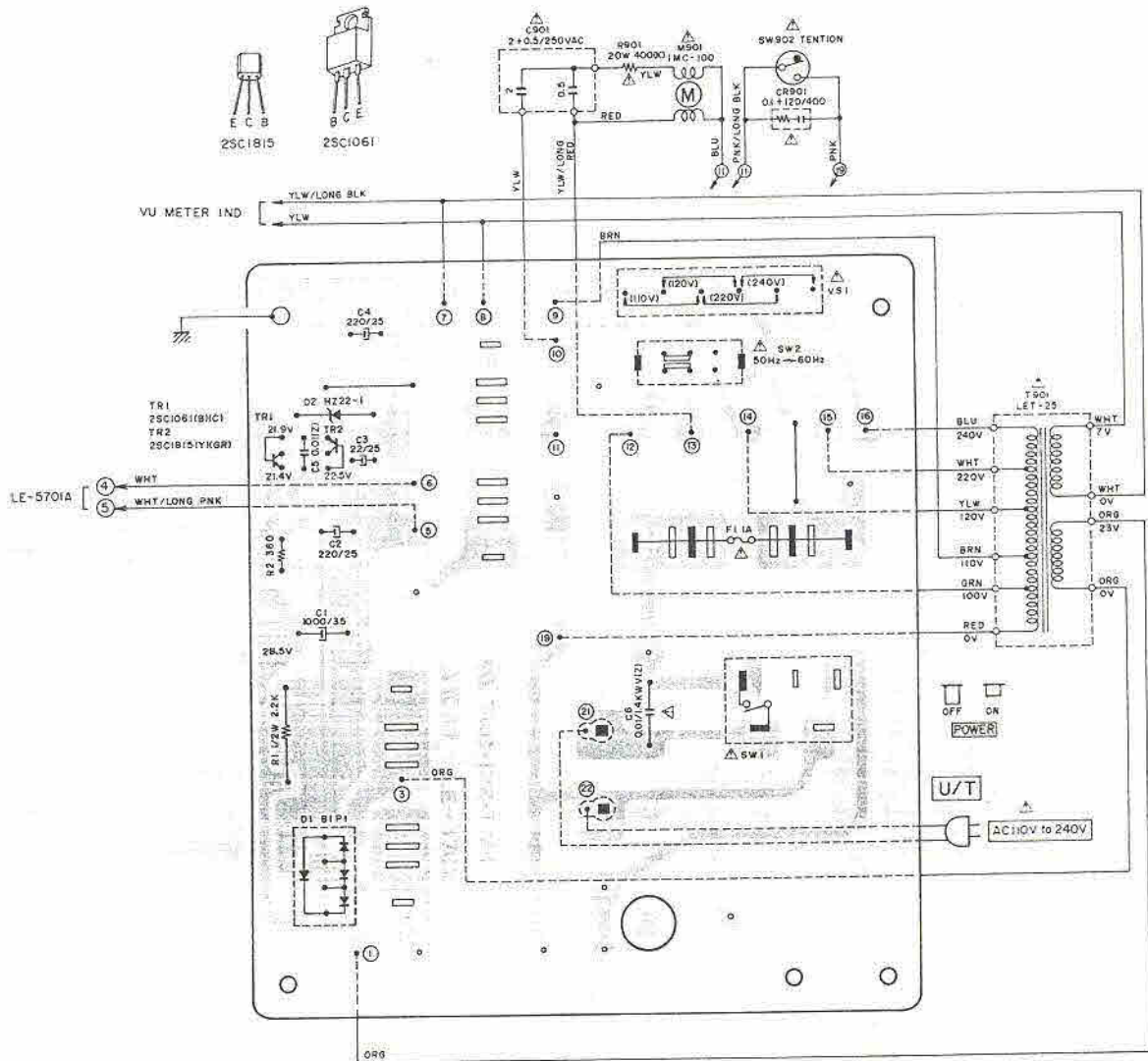

4) POWER SUPPLY P.C BOARD LE-5702 (CSA, AAL)

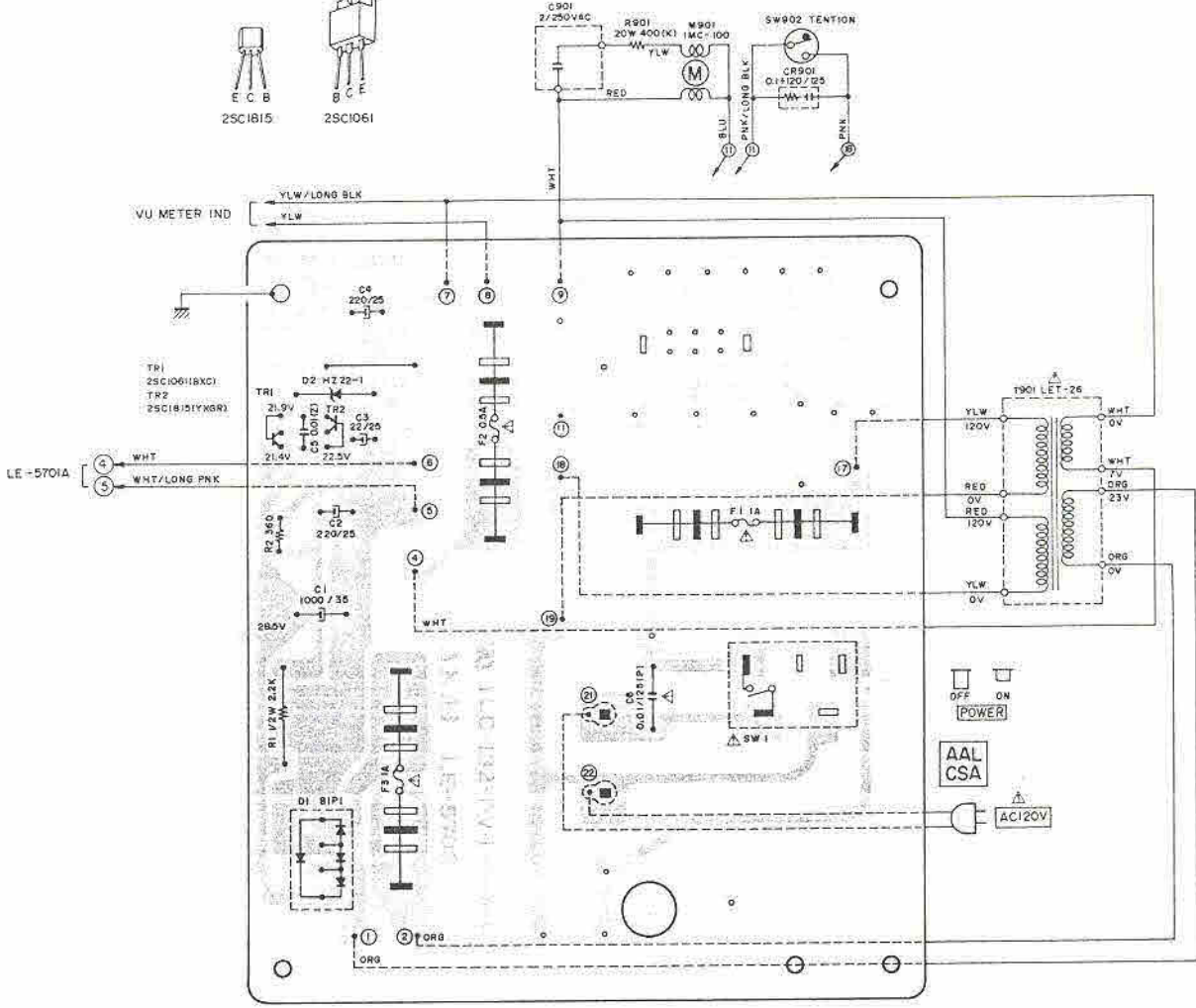
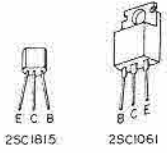

WARNING: INDICATES SAFETY CRITICAL COMPONENTS FOR CONTINUED SAFETY.
 REPLACE SAFETY CRITICAL COMPONENTS ONLY WITH MANUFACTURER'S
 RECOMMENDED PARTS.
 AVERTISSEMENT: LES COMPOSANTS CRITIQUES DE SÛRETÉ DOIVENT ÊTRE
 REMPLACÉS SEULEMENT PAR LES PIÈCES RECOMMANDÉES PAR LE FABRICANT.

SECTION 2

PARTS LIST

TABLE OF CONTENTS

1.	RECOMMENDED SPARE PARTS LIST	36
2.	HEAD BASE BLOCK	38
3.	MOTOR BLOCK (IMC-100)	40
4.	REEL TABLE BLOCK	42
5.	FLYWHEEL BLOCK	44
6.	SWITCH BLOCK	45
7.	MECHA ASSEMBLY BLOCK	46
8.	P.C BOARDS	48
	(1) AMP P.C BOARD (LE-5801A) BLOCK (GX-4000D)	48
	(2) AMP P.C BOARD (LE-5701A) BLOCK (GX-4000DB)	49
	(3) POWER SUPPLY P.C BOARD (LE-5802/LE-5702) BLOCK	50
9.	POWER/AMP ASSEMBLY BLOCK	52
10.	FINAL ASSEMBLY BLOCK	54
11.	LIST OF INTERCHANGEABLE SEMICONDUCTORS	56
	INDEX	57

Resistor and Capacitor which is not listed in this parts list, please refer to COMMON LIST FOR SERVICE PARTS.

HOW TO USE THIS PARTS LIST

1. This parts list is compiled by various individual blocks based on assembly process.
2. When ordering parts, please describe parts number, serial number, and model number in detail.
3. How to read List:

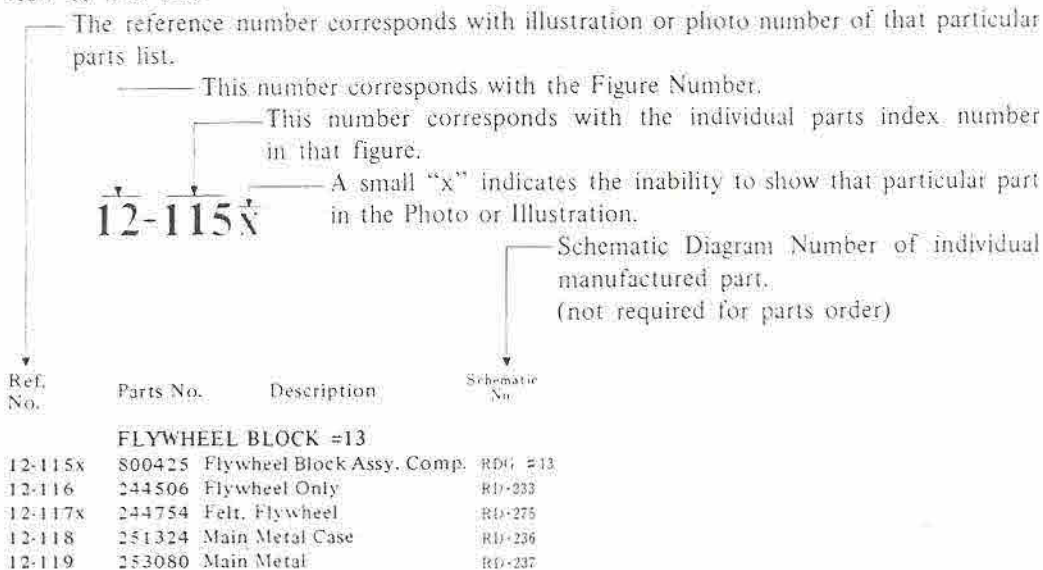

4. The symbol numbers shown on the P.C. Board list can be matched with the Composite Views of Components of the Schematic Diagram or Service Manual.
5. Please utilize separate "Common List for Service Parts" for Resistor Parts orders.
6. The shape of the parts and parts name, etc. can be confirmed by comparing them with the parts shown on the Electrical Parts Table of P.C. Board.
7. Both the kind of part and installation position can be determined by the Parts Number. To determine where a parts number is listed, utilize Parts Index at end of Parts List.
It is necessary first of all to find the Parts Number. This can be accomplished by using the Reference Number listed at right of parts number in the Parts Index. (meaning of ref. no. outlined in Item 3 above).
8. Utilize separate "Price List for Parts" to determine unit price. The most simple method of finding parts Price is to utilize the reference number.

CAUTION:

1. When placing an order for parts, be sure to list the parts no., model no., and description. There are instances in which if any of this information is omitted, parts cannot be shipped or the wrong parts will be delivered.
2. Please be careful not to make a mistake in the parts no. If the parts no. is in error, a part different from the one ordered may be delivered.
3. Because parts number and parts unit supply in the Preliminary Service Manual (Basic Parts List) may be partially changed, please use this parts list for all future reference.

WARNING: Δ INDICATES SAFETY CRITICAL COMPONENTS. FOR CONTINUED SAFETY, REPLACE SAFETY CRITICAL COMPONENTS ONLY WITH MANUFACTURER'S RECOMMENDED PARTS.

AVERTISSEMENT: Δ IL INDIQU LES COMPOSANTS CRITIQUES DE SURETE, POUR MAINTENIR LE DEGRE DE SECURITE DE L'APPAREIL NE REMPLACER LES COMPOSANTS DONT LE FONCTIONNEMENT EST CRITIQUE POUR LA SECURITE QUE PAR DES PIECES RECOMMANDEES PAR LE FABRICANT.

AC INLET SYSTEM

This model is equipped with an AC INLET SYSTEM. Please refer to the AC INLET SYSTEM CHART below for the specific type. By the AC INLET SYSTEM, AC (mains) cord can be connected to and disconnected from the model because the model is provided with socket exclusively for AC (mains) cord on its main body. Please note, however, that certain models are not equipped with this system and has a built-in AC (mains) cord as before.

AC INLET SYSTEM CHART

CLASS I

CLASS II

⊞ This mark indicating double insulation will be attached to machine's rear panel

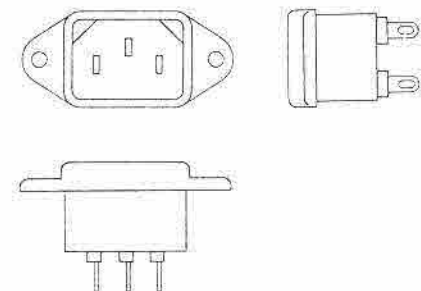

Picture 1
AC INLET
to be
installed
on machines

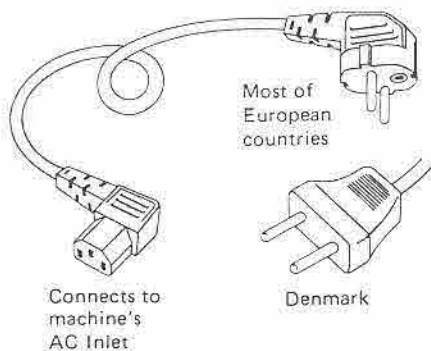
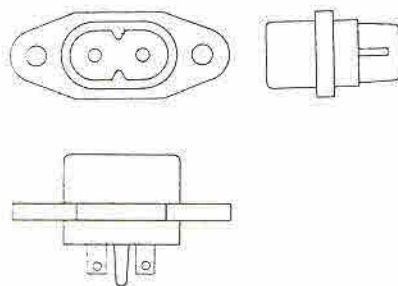

Picture 2
AC (mains)
cord

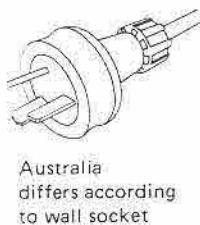
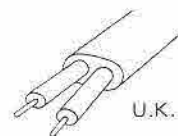
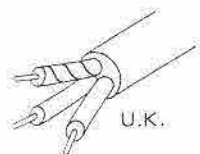
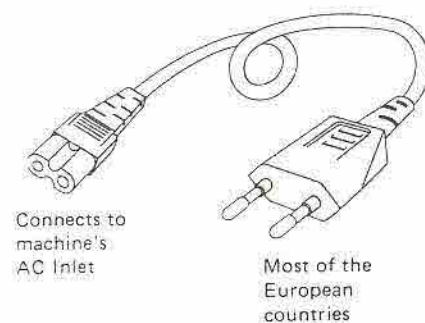

Parts List for AC (mains) Cord Set

	Standard	Description	Type of AC Inlet	Parts No.
Class I	CEE	Cord Set CEE (3 cores)	3P	EW302993
	BEAB	Cord Set BEAB (3 cores)	3P	EW302994
	SAA	Cord Set SAA (3 cores)	3P	EW302996
	U/T	Cord Set U/T (3 cores)	3P	EW302646
Class II	CEE	Cord Set CEE (2 cores)	2P	EW638144
	BEAB	Cord Set BEAB (2 cores)	2P	EW302995
	SAA	Cord Set SAA (2 cores)	2P	EW302991
	U/T	Cord Set U/T (2 cores)	2P	EW302899

1. RECOMMENDED SPARE PARTS LIST

Because, if the parts listed below are on hand, almost any repair can be accomplished, we suggest that you stock these Recommended Spare Parts Items.

Parts No.	Description	Note
BA306532	Amp P.C Board Comp. GX-4000D	
BA307132	Amp P.C Board Comp. GX-4000DB	
BA306543	Power Supply P.C Board Comp. GX-4000D (U/T)	
BA306544	Power Supply P.C Board Comp. GX-4000D (JPN)	
BA306545	Power Supply P.C Board Comp. GX-4000D (CSA, AAL)	
BA306547	Power Supply P.C Board Comp. GX-4000D (CEE, UK)	
BA307124	Power Supply P.C Board Comp. GX-4000DB (U/T)	
BA307125	Power Supply P.C Board Comp. GX-4000DB (CSA, AAL)	
BA307126	Power Supply P.C Board Comp. GX-4000DB (CEE, UK)	
BF205075	Flywheel Block Comp. #5 LE	
BH306536	Head Base Block Comp. GX-4000D	
BL311453	AS Lever Block Comp. GX-4000D	
BM306529	△ Motor Block Comp. (IMC-100) GX-4000D	
BR306554	Reel Table Block Comp. LE-8 (Take-up)	
BR306555	Reel Table Block Comp. LE-8 (Supply)	
BT306441	△ Power Trans. LET-24 (D-U/T)	T901
BT306439	△ Power Trans. LET-21 (D-JPN)	T901
BT306440	△ Power Trans. LET-22 (D-CSA, AAL)	T901
BT306442	△ Power Trans. LET-23 (D-CEE, UK)	T901
BT307232	△ Power Trans. LET-25 (DB-U/T)	T901
BT307231	△ Power Trans. LET-26 (DB-CSA, AAL)	T901
BT307233	△ Power Trans. LET-27 (DB-CEE, UK)	T901
ED624903	Silicon Diode 1S2473	
ED560913	Silicon Diode 1S2473VE	
ED224526	Silicon Diode 10D1	
ED306423	Silicon Diode B1P-1	
ED562386	Germanium Diode 1S188AM	
ED219464	Germanium Diode 1N34A	
ED310387	Zener Diode HZ12B-2	
ED306469	Zener Diode 05Z-22L	
ED307236	Zener Diode HZ22-1	DB
ED249377	LED GL-3AR1	
ED283138	LED GL-3PG1	DB
EI306141	IC LA4170	
EI301463	IC CR-713B	DB
EM306433	VU Meter D18C45R	
EM306432	VU Meter D18C43R (D-JPN)	
EM306434	VU Meter D18C44R (BL)	
EO383365	Osc Coil OT-204	
ES403727	△ Micro SW. V-1A106 U/L	
ES306291	Remote SW. SE-S243B	
ES307163	Remote SW. SE-S243B	DB

Parts No.	Description	Note
ES494302	Slide SW. CL-104B	
ES306292	Leaf SW. BSW-86	
ES306422	Push SW. SUF42	
ES306982	Push SW. SUF42	DB
ES655806	△ Push SW. SDG1P (U/T, JPN)	
ES665875	△ Push SW. SDG-1P U/L (CSA, AAL)	
ES665807	△ Push SW. SDG-5P 5A/80A 250V (CEE, UK)	
ES258232	△ Slide SW. S-2930 (U/T, JPN)	
ES316934	Rewind Shaft (Y Type)	
ES369865	Rewind Shaft (Y Type) RCC	
ET391768	Transistor 2SC458LG (C) (D)	
ET639437	Transistor 2SC945L (Q) (P)	
ET399846	Transistor 2SC945L (Q)	
ET398788	Transistor 2SC945L (R)	
ET603257	Transistor 2SC1312S (G) (H)	DB
ET663243	Transistor 2SC1312S (G)	DB
ET399870	Transistor 2SC711 (G)	DB
ET368021	Transistor 2SC458 (B) (C)	
ET537300	Transistor 2SD361 (D) (E)	
ET375603	Transistor 2SC1061 (B) (C)	DB
ET307234	Transistor 2SC1815 (Y) (GR)	DB
ET552870	FET 2SK30A (Y) (GR)	
ET301464	FET 2SK68 (M) (N)	DB
EV306293	Double axial 2 throw Vol. DM20R 611A 50 kAx2	
EV306981	Double axial 2 throw Vol. (w/SW) DM13E531A-UER42 50 kAx2	DB
EV306446	Single axial 2 throw Vol. GM70R706C 10 kBx2	
EV305635	Semi-fixed/Vol. D8 Axial Type 5 kB	
EV305636	Semi-fixed/Vol. D8 Axial Type 50 kB	
EV520806	Semi-fixed/Vol. V8K4-1 10 kB	DB
EV464220	Semi-fixed/Vol. V8K4-1 50 kB	DB
EV478686	Semi-fixed/Vol. V8K4-1 1 kB	DB
HE384693	ERASE HEAD E4-200	
HP307087	HEAD P4-241Σ	
HR307088	HEAD R4-241Σ	
MB256601	Double Face Flat Belt D110	
MB406168	Counter Belt D123x1.8	
MC479968	Counter Part MP-491-28	
MI675450	Middle Wheel (C)	
MI241413	Idler Wheel (D) Part LE-6	
MP204794	Pinch Roller Part LS	
MS244708	Flywheel Shaft	
MV639630	Roller, Resin LE	
MY270055	Capstan D8	
MZ283140	△ Voltage Changer 12M-60031 (U/T)	

2. ILLUSTRATION OF HEAD BASE BLOCK

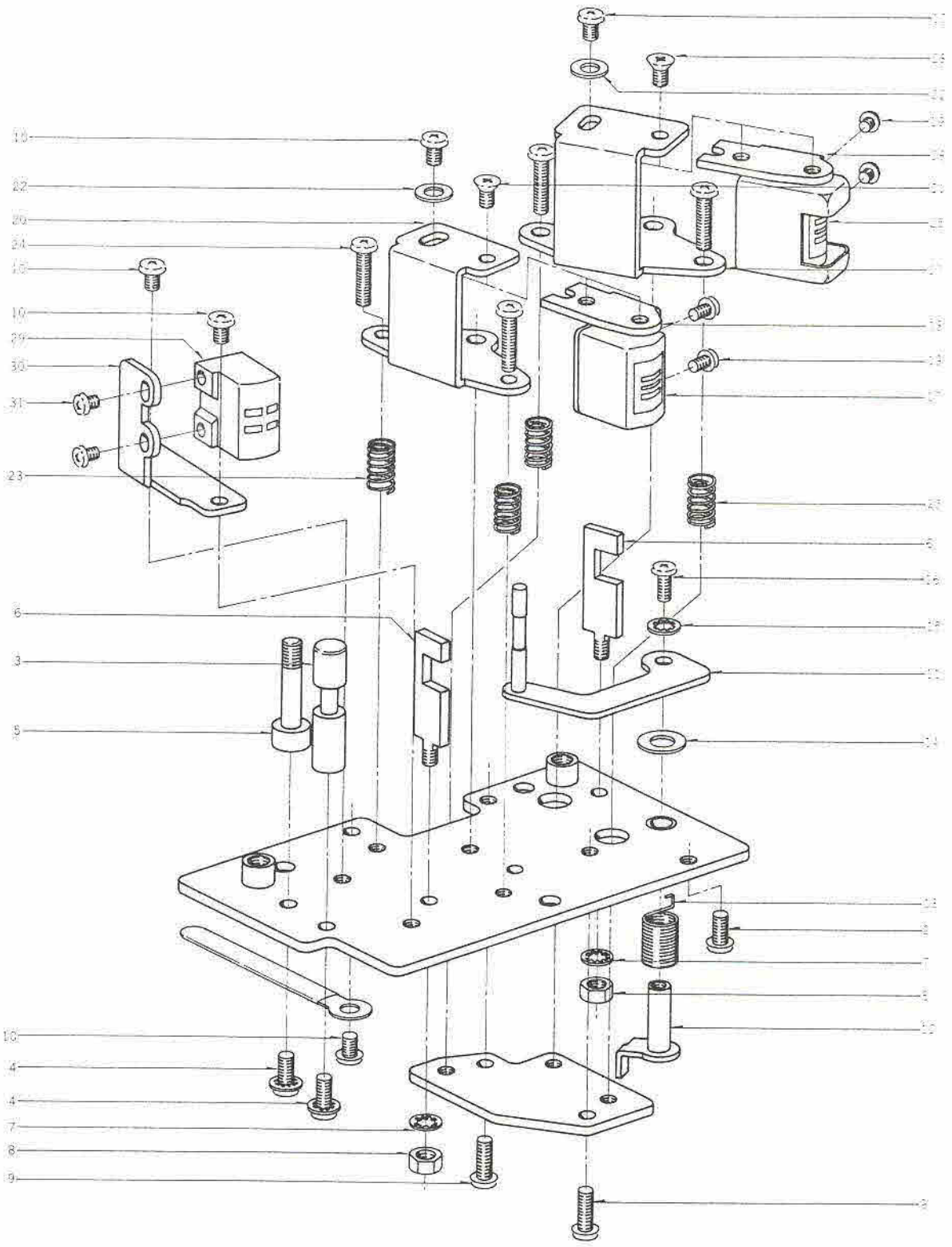

2) HEAD BASE BLOCK

Ref. No.	Parts No.	Description	Schematic No.
2-1x	BH306536	Head Base Block Comp. GX-4000D	
2-2	ZS379350	Screw, pan head 3x6	
2-3	HZ317597	MR Tape Guide (A)	MR-4
2-4	ZS558101	Screw, pan head 3x6 w/washer	
2-5	SZ276816	Capstan Rest. ST-1	100180
2-6	HZ274162	Tape Guide #1	4TR-5
2-7	ZW273802	Toothed Lock Washer. M3	
2-8	ZW516611	Nut M3	
2-9	ZS421806	Screw, pan head 3x8	
2-10	ZS417216	Screw, pan head 3x4	
2-11	ML306332	Shift Lever Part LE-8	LE-0707
2-12	ML676001	Shift Lever (B) Part LD	M9-3
2-13	ZG312928	Shifter Spring	LD-19
2-14	ZW420682	Washer (Nylon) D4.2x9x0.5t	
2-15	ZW269785	Toothed Lock Washer M2.3	
2-16	ZS464692	Screw, binding head 2.3x6	
2-17	HR307088	HEAD R4-241Σ	
2-18	HA306211	REC Angle	LE-0705
2-19	ZS460440	Screw, pan head 2x4	
2-20	HZ306249	REC Base	LE-0703
2-21	ZS327835	Screw, countersunk head 3x5	
2-22	ZW306464	Washer D3.1x7x0.5t	
2-23	ZG206144	Angle Adjust Spring	RD-16
2-24	ZS419670	Screw, pan head 3x12	
2-25	HP307087	HEAD P4-241Σ	
2-26	HA306210	PB Angle	LE-0704
2-27	HZ306246	PB Base	LE-0702
2-28	ZS444330	Screw, countersunk head 3x4	
2-29	HE384693	ERASE HEAD E4-200	
2-30	HZ410984	Erase Head Base	LF-0002
2-31	ZS477876	Screw, pan head 2x3	
2-32x	EJ309102	4P Micro Connector Part W-H8004-023	26-6-288
2-33x	EJ309103	4P Micro Connector Part W-H8004-022	26-6-289
2-34x	EJ309101	3P Micro Connector Part W-H8003-027	26-6-287

3. ILLUSTRATION OF MOTOR BLOCK (IMC-100)

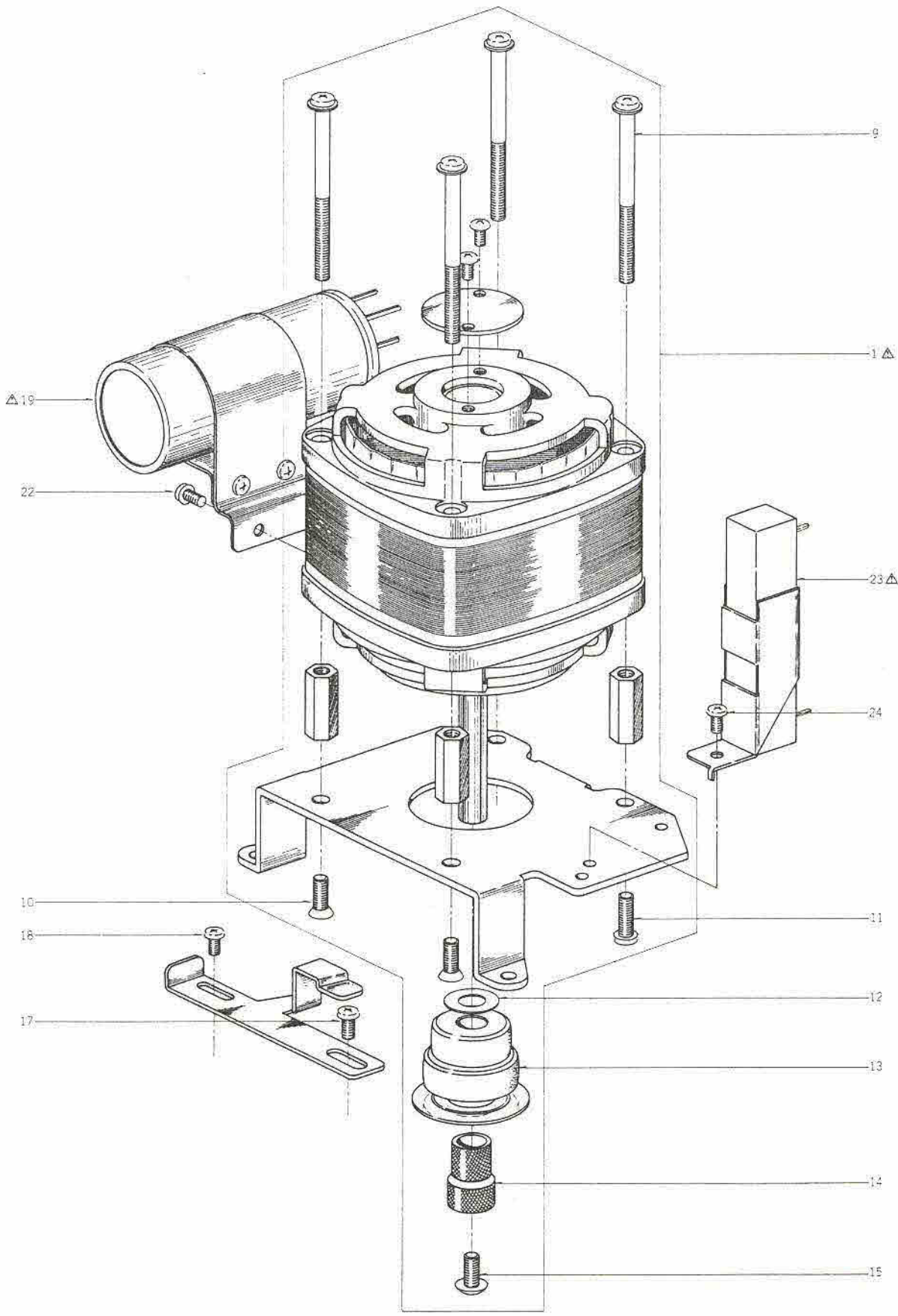

3) MOTOR BLOCK (IMC-100)

Ref. No.	Parts No.	Description	Schematic No.
3-1	BM306529	Motor Block Comp. (IMC-100) GX-4000D	
3-2x	EZ335204	Felt (C) D14x19x4t	900-744
3-3x	ZW283465	Washer D9x23.8x0.1t	
3-4x	ZW283476	Washer D9x23.8x0.2t	
3-5x	ZW283487	Washer D9x23.8x0.3t	
3-6x	ZW283498	Washer D9x23.8x0.4t	
3-7x	ZW283500	Washer D9x23.8x0.5t	
3-8x	MV269965	Steel Ball D4	
3-9	ZS427037	Screw, pan head 4x50, w/washer	
3-10	ZS427026	Screw, countersunk head 4x10	
3-11	ZS424056	Screw, pan head 4x10	
3-12	MZ210126	Oil Cut (A)	900-730
3-13	MR611976	Motor Pulley	SRA-5
3-14	MR300644	Knurling Pulley (900 Type)	900-735
3-15	ZS600816	Screw, truss head 4x8	
3-16x	ZS422076	Screw, pan head 3x5	
3-17	ZS417150	Screw, pan head 4x6	
3-18	ZS422076	Screw, pan head 3x5	
3-19	EC306424	Δ MP/C. (Wrap Type) 2+0.5μF 250VAC (U/T, JPN)	24-9-123
3-20x	EC309122	Δ MP/C. (Wrap Type) 2.5μF 260VAC (CEE)	24-9-126
3-21x	EC306425	Δ MP/C. (Wrap Type) 2μF 250VAC (CSA)	24-9-124
3-22	ZS323728	Screw, binding head 3x5	
3-23	ER306462	Δ Cement/R. 20W 400 ohms(K)	35-16-78
3-24	ZS608275	Screw, pan head 3x5 w/washer	

4. ILLUSTRATION OF REEL TABLE BLOCK

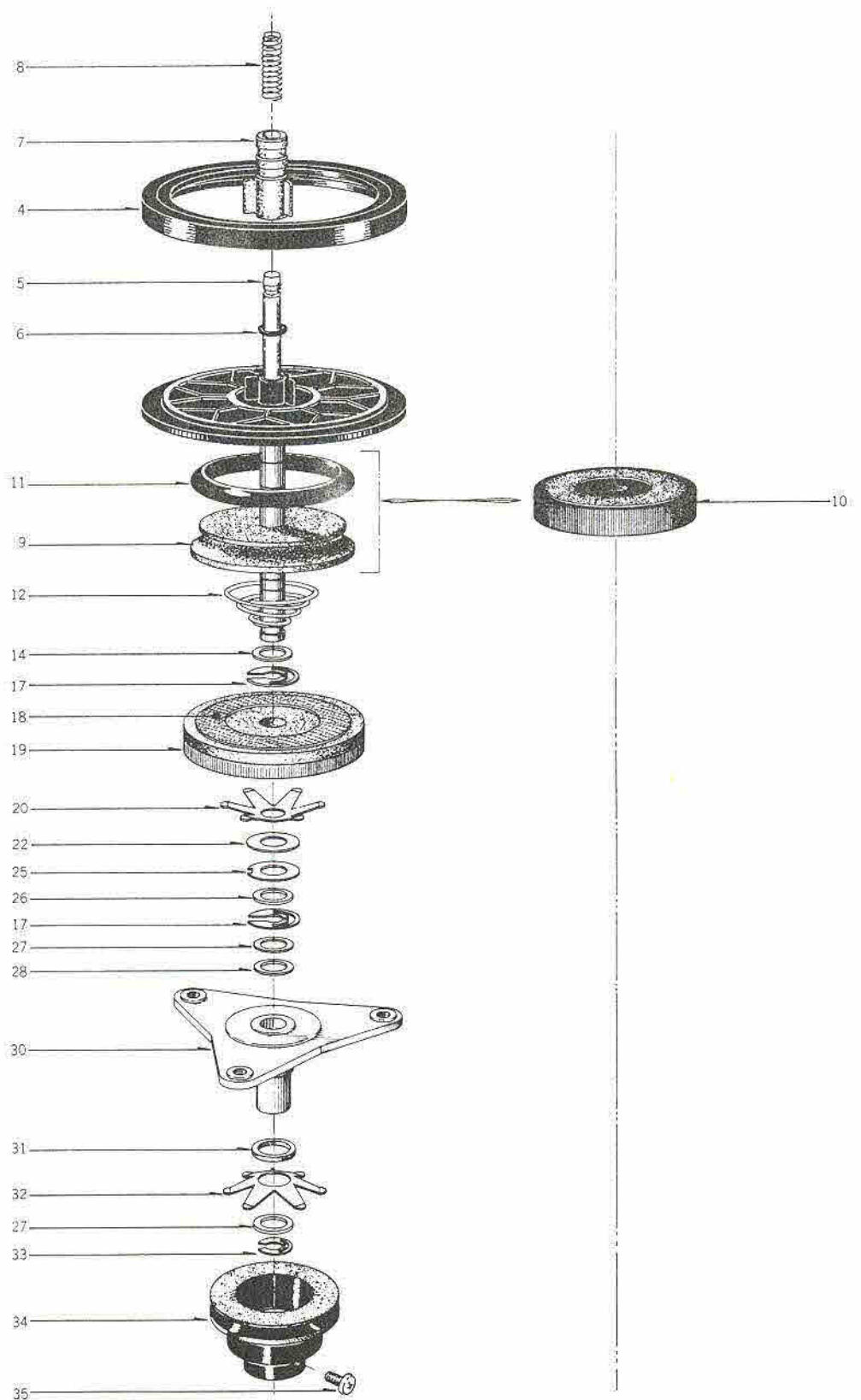

4) REEL TABLE BLOCK

Ref. No.	Parts No.	Description	Schematic No.
4-1x	BR306555	Reel Table Block Comp. LE-8 (Supply)	
4-2x	BR306554	Reel Table Block Comp. LE-8 (Take-up)	
4-3x	MT252112	Friction Cloth (B)	900-225
4-4	MT306237	Reel Table Rubber (Black)	LE-2703
4-5	MS306208	Reel Shaft	LE-2705
4-6	MT516565	'O' Ring 2.8x1.9	3R-139
4-7	MT458943	Reel Retainer	3R-102
4-8	ZG306241	Reel Spring	LE-2706
4-9	MR251460	Rewind Pulley	900-223
4-10	MR252044	Take-up Roller (A)	900-221
4-11	MT222366	Rubber Ring	900-234
4-12	ZG227553	Spring G-2 (L)	900-230
4-13x	ZG227542	Spring G-2 (R)	900-230
4-14	ZW260054	Washer (SUP) D6.1x10x0.25t	
4-15x	ZW260065	Washer (SUP) D6.1x10x0.35t	
4-16x	ZW260098	Washer (SUP) D6.1x10x0.5t	
4-17	MT255870	Reel Table Thrust Retainer Pin	900-237
4-18	MT252123	Friction Cloth (C)	900-226
4-19	MR252055	Take-up Roller (B)	900-221
4-20	MT255971	Reel Table Spring Plate (A)	900-227
4-21x	MT255982	Reel Table Spring Plate (B)	900-228
4-22	ZW553972	Washer (Nylon) D6.2x13x0.8t	
4-23x	MT438636	Reel Torque Adjust Thrust (6) D6.2x13x1t	101021
4-24x	MT438592	Reel Torque Adjust Thrust (2) D6.1x10x0.3t	101017
4-25	ZW231693	Thrust Washer. w/claw	900-235
4-26	ZW260021	Washer (SUP) D6.1x10x0.13t	
4-27	MT438625	Reel Torque Adjust Thrust (5) D6.1x10.3x1t	101020
4-28	MT438581	Reel Torque Adjust Thrust (1) D5.8x10.3x1t	101016
4-29x	ZW260043	Washer (Nylon) D6.1x10x0.2t	
4-30	MT676383	XR Reel Metal Mt. Parts Part LS	XR-191B
4-31	ZW437804	Flywheel Thrust (A) D7.9x13x1t	101024
4-32	MT255993	Reel Table Spring Plate (C)	M8-207
4-33	ZW270000	Retaining Pin D4	900-257
4-34	MR256083	Reel Table Pulley	900-239
4-35	ZS379350	Screw, pan head 3x6	
4-36x	ZS421806	Screw, pan head 3x8	

5. ILLUSTRATION OF FLYWHEEL BLOCK

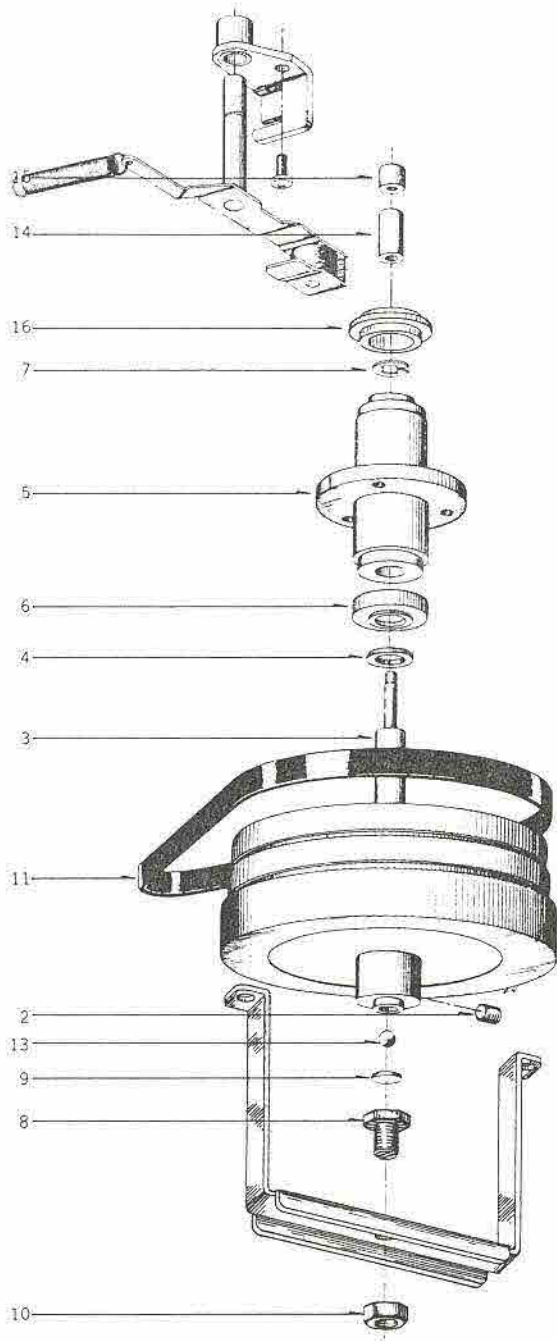

5) FLYWHEEL BLOCK

Ref. No.	Parts No.	Description	Schematic No.
5-1x	BF205075	Flywheel Block Comp. #5 LE	
5-2	ZS687126	Set Screw, hexagon socket 5x5 (Flat/P.)	
5-3	MS244708	Flywheel Shaft	SRA 21
5-4	ZW447208	Flywheel Thrust (B) D7.9x13x0.5t	101025
5-5	MZ675887	Main Case Part 1630	1630-205
5-6	MZ446635	Thrust Cap, main metal B2	LF-2006
5-7	MH244710	Flywheel Fixing Pin	900-250
5-8	MZ585900	Shaft Support	LS-1203
5-9	ZW285873	Washer D8x1.5t (w/o hollow) (Nylon)	
5-10	ZW413278	Nut M5, #1	
5-11	MB256601	Double Face Flat Belt D110	100912
5-12	ZS413177	Screw, pan head 4x10 w/washer	
5-13	MV269965	Steel Ball D4	
5-14	MY270055	Capstan D8	SRA-7
5-15	ZS284231	Capstan Screw, 1100	SRA-6B
5-16	MZ301585	Metal Cap	LE-6607
5-17x	MZ306436	Metal Cap (BL)	LE-6607

When ordering parts, please describe Parts Number, Description, and Model Number in detail.

6. ILLUSTRATION OF SWITCH BLOCK

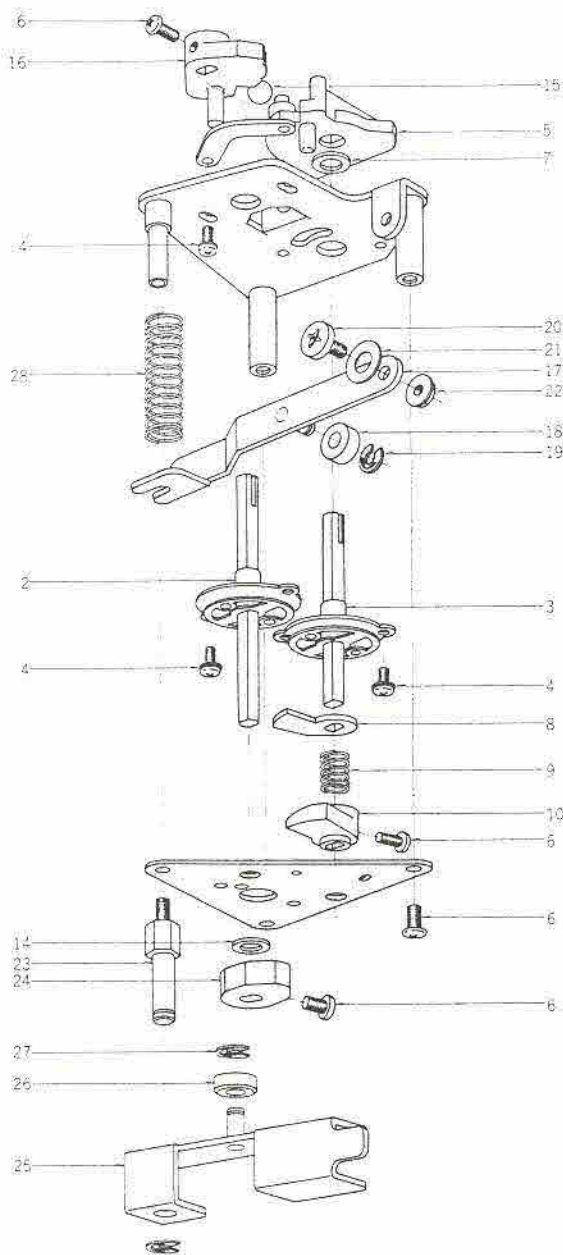

6) SWITCH BLOCK

Ref. No.	Parts No.	Description	Schematic No.
6-1x	BS480352	SW. Block Comp. LE	LE-2301
6-2	ES316934	Rewind Shaft (Y Type)	25-8-5
6-3	ES369865	Rewind Shaft (Y Type), RCC	RCC-202
6-4	ZS558101	Screw, pan head 3x6 w/washer	
6-5	MZ610301	Cam (A-3)	MR-242
6-6	ZS413201	Screw, pan head 4x8	
6-7	ZW260133	Washer (Fiber) D6.1x10x1t (Black)	
6-8	MZ327341	Cam Trap Plate (B)	SX-201
6-9	ZG227586	Spring (K)	900-214
6-10	MZ327352	Cam (C-2)	SX-202
6-11x	ZW260144	Washer (Nylon) D6.1x10x0.3t	
6-12x	ZW260076	Washer (Nylon) D6.1x10x0.5t	
6-13x	ZW260111	Washer (Nylon) D6.1x10x0.8t	
6-14x	ZW322110	Washer (Nylon) D6.1x10x1t	
6-15	MV270066	Steel Ball D8	
6-16	MZ217271	Cam (B), w/o tap	900-206
6-17	ML675854	Lever (1) Part 900	900-209
6-18	MR217203	Cam Roller (A) D12	900-153
6-19	ZW290283	'U' Ring 2.85M	6-1-1
6-20	ZS217877	Pause Lever Set Screw	900-136
6-21	ZW432347	Washer (Luminar) D6.2x13x0.125t	
6-22	ZW413267	Flange Nut M4	
6-23	MH258581	REC Lever Prop	M9-303
6-24	MZ206515	Amp SW. Cam (B)	MR-243
REC LEVER BLOCK			
6-25	ML305715	REC Lever Part LE-8	LE-6730
6-26	MR217203	Cam Roller (A) D12	900-153
6-27	ZW290283	'U' Ring 2.85M	6-1-1
6-28	ZG227485	Spring (E)	900-119

When ordering parts, please describe Parts Number, Description, and Model Number in detail.

7. ILLUSTRATION OF MECHA ASSEMBLY BLOCK

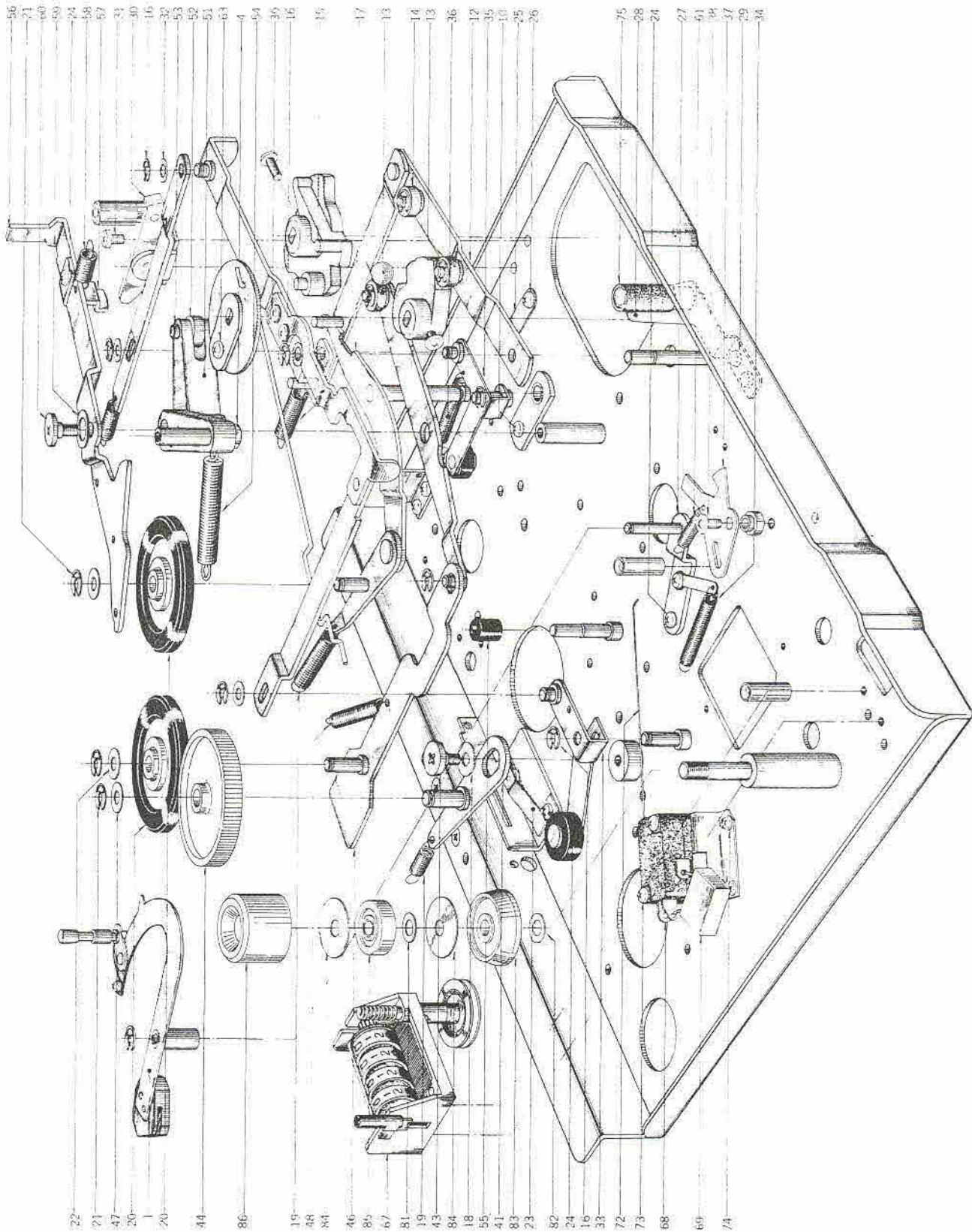

7) MECHA ASSEMBLY BLOCK

Ref. No.	Parts No.	Description	Schematic No.	Ref. No.	Parts No.	Description	Schematic No.
AS LEVER BLOCK				Remote SW. (Selector)			
7-1	BL311453	AS Lever Block Comp. GX-4000D		7-65x	ES306460	SE-S243B	25-9-7
7-2x	ZG260717	AS Lever Spring (B)	4TR-231	7-66x	ES307180	Remote SW. (Selector) SE-S243B L=200 (DB)	25-9-8 9-1-23
MECHA ASSEMBLY BLOCK				7-67	MC479968	Counter Part MP-491-28	25-1-20
7-3x	ZW273914	Spring Washer, M4		7-68	ES403727	Δ Micro SW. V-1A106 U/L	
7-4	ZW413188	Nut M4, #1		7-69	ER450786	Δ Spark Quencher U/L 0.1μ+120 ohms 400WV	41-1-33
7-5x	ZS413201	Screw, pan head 4x8		7-70x	ER300820	Δ Spark Quencher CRU-112 0.1μ+120 ohms 125WV (CSA)	41-1-63
7-6	ZS414044	Screw, countersunk head 4x8		7-71x	EC301320	Δ MP/C. 4700PF(M) 250WV (CEE)	24-9-122 LS-1202
7-7x	ZS325495	Tapping Screw =2. 3x6 (BR)		7-72	MZ585887	Actuator (B) Part LS-2	
7-8x	ZS600816	Screw, truss head 4x8		7-73	ZS419670	Screw, pan head 3x12	
7-9x	ZS447840	Tapping Screw =2. 3x8 (BR)		7-74	ZS422076	Screw, pan head 3x5	
7-10	ZS424056	Screw, pan head 4x10		7-75	SB625004	REC Button (RED)	900-167
7-11x	ZW413267	Flange Nut M4		7-76x	MB406168	Counter Belt D123x1.8	3-3-14
7-12	ML663355	Lever (B.D) Part 900	900-103	7-77x	SA311202	Rubber Foot (A) Part	LE-6739
7-13	MR217203	Cam Roller (A) D12	900-153	7-78x	ZW601075	Washer (PBP) D4.1x7x0.1t	
7-14	MR217214	Cam Roller (B)	4TR-240	7-79x	ZW322525	Washer (PBP) D4.1x7x0.2t	
7-15	ZG469427	Spring (B-1)	LS-2004	7-80x	ZW649991	Washer (PBP) D4.1x7x0.3t	
7-16	ZW290283	'U' Ring 2.85M	6-1-1				
7-17	ML663401	G.H. Lever Part 900					
7-18	ZW432347	Washer (Luminar) D6.2x13x0.125t		7-81	ZW285862	Washer D5.1x10.3x0.1t	
7-19	ZG227575	Spring (I)	900-121	7-82	ZW326463	Washer (PBP) D5.1x10.3x0.2t	LC-618
7-20	MI241413	Idle Wheel (D) Part LE-6	LE-1610	7-83	SZ465377	Tape Guide Table (A)	3A-356
7-21	ZW290294	'U' Ring 2.85M	6-1-1B	7-84	ZW231805	Tape Guide Washer (Large)	LE-1607
7-22	ZW260054	Washer (SUP) D6.1x10x0.25t		7-85	MV639630	Roller, Resin LE	LE-6715
7-23	ZG257095	Lever FB Vibration Proof Spring	M8-104	7-86	SH306225	Tape Guide Cap	
7-24	ZS323728	Screw, binding head 3x5					
7-25	MZ217708	Pause Lever Retaining Parts (B)	900-170				
7-26	ZS413234	Screw, pan head 4x12					
7-27	ML663761	AS Lever Prop Base Part 4TR	4TR-236				
7-28	MZ628211	REC Stopper	LE-1602				
7-29	ZS417150	Screw, pan head 4x6					
7-30	ML674357	Start Lever Part MS	4TR-122				
7-31	ZS417216	Screw, pan head 3x4					
7-32	ZW259942	Washer (Fiber) D5.1x10.3x0.5t					
7-33	ML668700	Supply Brake Part 900	900-113				
7-34	ZG290384	UN Spring (D)	1630-108				
7-35	ML668687	Take-up Brake Part LE	900-114				
7-36	ZG227452	Spring (D)	900-118				
7-37	MZ312524	Cam, shifter	LD-106				
7-38	ZS593177	Screw, truss head 3x8					
7-39	ZS201767	Screw, pan head 4x6, w/washer					
7-40x	ZW369595	Washer (Pressboard) D5.1x10.3x0.25t					
7-41	ML663805	Lever (K) Part 900	900-111				
7-42x	ZW283803	Washer (Luminar) D6.2x13x0.2t					
7-43	ZS223233	Fulcrum Screw (A)	900-135				
7-44	MI675450	Middle Wheel (C)	LE-1006				
7-45x	ZW321906	Washer (Nylon) D8.1x13x0.2t					
7-46	ML663827	2-speed Motor Lever (F) Part M8	M8-107				
7-47	ZW376391	Washer (Polyslider) D6.1x10x0.13t					
7-48	ZG270358	F.B Pull Spring	M8-108				
7-49x	ZW260111	Washer (Nylon) D6.1x10x0.8t					
7-50x	ZW376380	Washer (Polyslider) D5.1x10.3x0.13t					
7-51	ML663816	Pinch Roller Lever Part 4TR					
7-52	MR269763	Cam Roller D13	900-154				
7-53	MS582906	Cam Roller Shaft (A-1)	7-3-6				
7-54	ZG227417	Spring (A)	900-115				
7-55	MZ610457	Pause Lever Cushion	LE-1005				
7-56	ML479957	Pause Lever, LE	LE-1001				
7-57	MZ217855	Pause Stopper	900-169				
7-58	ZG217866	Pause Lever Spring (A)	900-123				
7-59	ZW260010	Washer (PBP) D6.1x10x0.1t					
7-60	MH289168	Pause Lever Fastener	LE-1007				
7-61	ZG208091	Impedance Arm Spring	RD-269				
7-62x	ZW260133	Washer (Fiber) D6.1x10x1t (Black)					
7-63	ZS608321	Screw, pan head 3x6 W=8					
7-64x	MZ256814	Rewind Shaft Spacer	M9-124				

When ordering parts, please describe Parts Number, Description, and Model Number in detail.

8. P.C BOARDS

(1) AMP P.C BOARD (LE-5801A) BLOCK (GX-4000D)

Symbol No.	Parts No.	Description	Schematic No.	Symbol No.	Parts No.	Description	Schematic No.
(1)-I	BA306532	Amp P.C Board Comp. GX-4000D		(1)-C2	EC306471	Elect./C. (LL, Homing Type) 10μF 25WV	24-20-18
(1)-IC1	EI306141	IC LA4170	45-8-305	(1)-C3	EC306980	Styrol/C. 220PF(J) 50WV	24-11-14
(1)-TR1to3	ET391768	Transistor 2SC458LG(C)(D)	45-1-29	(1)-C12	EC621257	Solid Aluminum/C. (Vert. Type)	
(1)-TR4,5	ET639437	Transistor 2SC945L(Q)(P)	45-1-85			0.47μF(M) 25WV	24-19-2
(1)-TR6to9	ET391768	Transistor 2SC458LG(C)(D)	45-1-29	(1)-C15	EC306420	Styrol/C. 750PF(J) 50WV	24-11-14
(1)-TR10	ET639437	Transistor 2SC945L(Q)(P)	45-1-85	(1)-C21	EC305680	Styrol/C. 150PF(J) 50WV	24-11-14
(1)-TR11	ET399846	Transistor 2SC945L(Q)	45-1-85	(1)-C22	EC306471	Elect./C. (LL, Homing Type) 10μF 25WV	24-20-18
(1)-TR12,13	ET398788	Transistor 2SC945L(R)	45-1-85	(1)-C23	EC306980	Styrol/C. 220PF 50WV	24-11-14
(1)-TR14to16	ET391768	Transistor 2SC458LG(C)(D)	45-1-29	(1)-C26	EC306419	Styrol/C. 680PF(J) 50WV	24-11-14
(1)-TR17,18	ET639437	Transistor 2SC945L(Q)(P)	45-1-85	(1)-C30	EC306438	Styrol/C. 100PF(J) 50WV	24-11-14
(1)-TR19to22	ET391768	Transistor 2SC458LG(C)(D)	45-1-29	(1)-C39	EC306470	Elect./C. (LL, Homing Type) 33μF 25WV	24-20-18
(1)-TR23	ET639437	Transistor 2SC945L(Q)(P)	45-1-85	(1)-C49	EC306471	Elect./C. (LL, Homing Type) 10μF 25WV	24-20-18
(1)-TR24	ET399846	Transistor 2SC945L(Q)	45-1-85	(1)-C50	EC306980	Styrol/C. 220PF(J) 50WV	24-11-14
(1)-TR25,26	ET552870	FET 2SK30A(Y)(GR)	45-12-4	(1)-C59	EC621257	Solid Aluminum/C. (Vert. Type)	
(1)-D1.2	ED562386	Germanium Diode 1S188AM	45-3-24			0.47μF(M) 25WV	24-19-2
(1)-D3	ED624903	Silicon Diode 1S2473	45-3-28	(1)-C61	EC306471	Elect./C. (LL, Homing Type) 10μF 25WV	24-20-18
(1)-D5.6	ED562386	Germanium Diode 1S188AM	45-3-24	(1)-C62	EC306420	Styrol/C. 750PF(J) 50WV	24-11-14
(1)-D7	ED224526	Silicon Diode 10D1	45-2-11	(1)-C68	EC305680	Styrol/C. 150PF(J) 50WV	24-11-14
(1)-D8	ED624903	Silicon Diode 1S2473	45-3-28	(1)-C69	EC306471	Elect./C. (LL, Homing Type) 10μF 25WV	24-20-18
(1)-L1	EO306418	Inductor RX-9P 1.2mH(K)	23-1-275	(1)-C70	EC306980	Styrol/C. 220PF(J) 50WV	24-11-14
(1)-L2	EO306417	Inductor RX-9P 3.3mH(K)	23-1-275	(1)-C73	EC306419	Styrol/C. 680PF(J) 50WV	24-11-14
(1)-L3	EO482905	Ferri Inductor FL9H 220μH(J)	23-1-4	(1)-C95	EC306474	Styrol/C. 1800PF(K) 500WV	24-11-16
(1)-L5	EO383365	Osc Coil OT-204	23-4-20	(1)-C100,101	EC306438	Styrol/C. 100PF(J) 50WV	24-11-14
(1)-L6	EO306418	Inductor RX-9P 1.2mH(K)	23-1-275	(1)-C103	EC306438	Styrol/C. 100PF(J) 50WV	24-11-14
(1)-L7	EO306417	Inductor RX-9P 3.3mH(K)	23-1-275				
(1)-L8	EO482905	Ferri Inductor FL9H 220μH(J)	23-1-4				
(1)-VL1to4	EO624857	Inductor GE6070A 23mH	23-1-227				
(1)-J1	EJ306289	Mic Jack HLJ0278-01-010	31-2-91				
(1)-J2	EJ283094	4P Pin Jack 1-01-0107-01	31-5-137				
(1)-J3	EJ306290	Headphone Jack JL3A	31-2-92				
(1)-SW1	ES306291	Remote SW. SE-S243B	25-9-7				
(1)-SW2	ES494302	Slide SW. CL-104B	25-3-79				
(1)-SW3	ES306292	Leaf SW. BSW-86	25-10-21				
(1)-VR1	EV305635	Semi-fixed/Vol. D8 Axial Type 5 kΩ	36-10-273				
(1)-VR2	EV305636	Semi-fixed/Vol. D8 Axial Type 50 kΩ	36-10-273				
(1)-VR3,4	EV305635	Semi-fixed/Vol. D8 Axial Type 5 kΩ	36-10-273				
(1)-VR5	EV305636	Semi-fixed/Vol. D8 Axial Type 50 kΩ	36-10-273				
(1)-VR6	EV305635	Semi-fixed/Vol. D8 Axial Type 5 kΩ	36-10-273				
(1)-VR7,8	EV306293	Double axial 2 throw Vol. DM20R611A 50 kΩx2	36-18-12				
(1)-VR9	EV306446	Single axial 2 throw Vol. GM70R706C 10 kΩx2	36-1-55				
(1)-P901,902	EJ249333	Micro Connector 4P Plug W-P0504	42-1-104				
(1)-P903	EJ302984	Micro Connector 3P Plug W-P0503	42-1-104				
(1)-R74,75	ER305722	Metal Oxide Film/R. (Homing Type) 2W 220 ohms(J)	35-11-22				
(1)-R76	ER306416	Metal Oxide Film/R. (Homing Type) 2W 270 ohms(J)	35-11-22				
(1)-VC1.2	EC558202	Trimmer/C. TM-80A 80PF	24-2-25				

SW. P.C BOARD (LE-5801C) BLOCK

(1)-SW4	ES306422	Push SW. SUF42	25-5-275
(1)-D4	ED560913	Silicon Diode 1S2473 VE	45-3-23

When ordering parts, please describe Parts Number, Description, and Model Number in detail.

(2) AMP P.C BOARD (LE-5701A) BLOCK
(GX-4000DB)

Symbol No.	Parts No.	Description	Schematic No.	Symbol No.	Parts No.	Description	Schematic No.
(2)-I1	BA307132	Amp P.C Board Comp. GX-4000DB		(2)-C38	EC306987	Styrol/C. (Homing Type) 470PF(J) 50WV	24-11-14
(2)-IC1,2	EI301463	IC CR-713B	45-8-225	(2)-C41	EC303025	Solid Aluminum/C. (Vert. Type) 0.22μF(K) 25WV	24-19-2
(2)-IC3	EI306141	IC LA4170	45-8-305	(2)-C43	EC306980	Styrol/C. 220PF(J) 50WV	24-11-14
(2)-TR1	ET391768	Transistor 2SC458LG(C)(D)	45-1-29	(2)-C44	EC306988	Styrol/C. (Homing Type) 330PF(J) 50WV	24-11-14
(2)-TR2	ET603257	Transistor 2SC1312S(G)(H)	45-1-182	(2)-C57	EC619650	Solid Aluminum/C. (Vert. Type) 0.1μF(K) 25WV	24-19-2
(2)-TR3	ET663243	Transistor 2SC1312S(G)	45-1-182	(2)-C58	EC604102	Solid Aluminum/C. (Vert. Type) 0.33μF(K) 25WV	24-19-2
(2)-TR4	ET399870	Transistor 2SC711(G)	45-1-67	(2)-C77	EC661972	Styrol/C. (Tub. Type) 1500PF(J) 250WV	24-11-10
(2)-TR5	ET391768	Transistor 2SC458LG(C)(D)	45-1-29	(2)-R94	ER306962	Metal Oxide Film/R. (Homing Type) 2W 360 ohms(J)	35-11-22
(2)-TR6	ET603257	Transistor 2SC1312S(G)(H)	45-1-182	(2)-R95	ER306961	Metal Oxide Film/R. (Homing Type) 2W 150 ohms(J)	35-11-22
(2)-TR7	ET301464	FET 2SK68(M)(N)	45-12-14	(2)-2	ZS325495	Tapping Screw #2, 3x6 (BR)	
(2)-TR8,9	ET368021	Transistor 2SC458(B)(C)	45-1-26				
(2)-TR10	ET375603	Transistor 2SC1061(B)(C)	45-1-96				
(2)-TR11,12	ET639437	Transistor 2SC945L(Q)(P)	45-1-85				
(2)-D1,2	ED219464	Germanium Diode 1N34A	45-3-1				
(2)-D3to5	ED624903	Silicon Diode 1S2473	45-3-28				
(2)-D6	ED310387	Zener Diode HZ12B-2	45-6-80				
(2)-D7,8	ED219464	Germanium Diode 1N34A	45-3-1				
(2)-FL1	ER309120	Dolby Filter D07-003	53-1-143				
(2)-FL2	ER307182	Low Pass Filter 12A-938	53-1-127				
(2)-FL3	ER309119	Dolby Filter D07-001	53-1-143				
(2)-L1	EO301711	Inductor RX-9P 3.3mH(J)	23-1-275				
(2)-L2	EO301448	Inductor 45H-044 1 mH	23-1-277				
(2)-L3,4	EO482905	Ferri Inductor FL9H 220μH(J)	23-1-4				
(2)-T1	EO383365	OSC Coil OT-204	23-4-20				
(2)-VR1	EV306293	Double axial 2 throw Vol. DM10R589A 50 kAx2	36-18-12				
(2)-VR2	EV306981	Double axial 2 throw Vol. (w/SW.) DM13E531A-UER42 50 kAx2	36-5-4				
(2)-VR3	EV520806	Semi-fixed/Vol. V8K4-1 10 kB	36-10-266				
(2)-VR4	EV464220	Semi-fixed/Vol. V8K4-1 50 kB	36-10-266				
(2)-VR5	EV478686	Semi-fixed/Vol. V8K4-1 1 kB	36-10-266				
(2)-VR6	EV306446	Single axial 2 throw Vol. GM70R706C 10 kBx2	36-1-55				
(2)-J1	EJ306289	Mic Jack HLJ0278-01-010	31-2-91				
(2)-J2	EJ306985	4P Pin Jack	31-5-142				
(2)-J3	EJ306290	Headphone Jack JL3A	31-2-92				
(2)-SW1	ES306982	Push SW. SUF42	25-5-276				
(2)-SW2	ES494302	Slide SW. CL104B	25-3-79				
(2)-SW3	ES307163	Remote SW. SE-S243B	25-9-8				
(2)-SW5	ES306292	Leaf SW. BSW-86	25-10-31				
(2)-P1,2	EJ249333	Micro Connector 4P Plug W-P0504	42-1-104				
(2)-P3	EJ302984	Micro Connector 3P Plug W-P0503	42-1-104				
(2)-VC1,2	EC558202	Trimmer/C. TM-80A 80PF	24-2-26				
(2)-C1	EC307167	Elect./C. (LL. Homing Type) 10μF 16WV	24-20-18				
(2)-C3	EC306986	Styrol/C. (Homing Type) 220PF(K) 50WV	24-11-14				
(2)-C5	EC307243	Elect./C. (LL. Homing Type) 2.2μF 50WV	24-20-18				
(2)-C21	EC619650	Solid Aluminum/C. (Vert. Type) 0.1μF(K) 25WV	24-19-2				
(2)-C22	EC604102	Solid Aluminum/C. (Vert. Type) 0.33μF(K) 25WV	24-19-2				
(2)-C30	EC306420	Styrol/C. 750PF(J) 50WV	24-11-14				
(2)-C35	EC306438	Styrol/C. 100PF(J) 50WV	24-11-14				
(2)-C36	EC307167	Elect./C. (LL. Homing Type) 10μF 16WV	24-20-18				
(2)-C37	EC250672	Elect./C. (Vert. Type) 47μF 16WV NL	24-20-4				

When ordering parts, please describe Parts Number, Description, and Model Number in detail.

(3) POWER SUPPLY P.C BOARD (LE-5802/LE-5702) BLOCK

Symbol No.	Parts No.	Description	Schematic No.
(3)-1	BA306543	Power Supply P.C Board Comp. GX-4000D (U/T)	LE-5805
(3)-2	BA306544	Power Supply P.C Board Comp. GX-4000D (JPN)	LE-5805
(3)-3	BA306545	Power Supply P.C Board Comp. GX-4000D (CSA, AAL)	LE-5805
(3)-4	BA306547	Power Supply P.C Board Comp. GX-4000D (CEE, UK)	LE-5805
(3)-5	BA307124	Power Supply P.C Board Comp. GX-4000DB(U/T)	LE-5711
(3)-6	BA307125	Power Supply P.C Board Comp. GX-4000DB (CSA, AAL)	LE-5711
(3)-7	BA307126	Power Supply P.C Board Comp. GX-4000DB (CEE, UK)	LE-5711
(3)-TR1	ET537300	Transistor 2SD361(D)(E)	45-1-143
(3)-TR1	ET375603	Transistor 2SC1061(B)(C) (DB)	45-1-96
(3)-TR2	ET307234	Transistor 2SC1815(Y)(GR) (DB)	45-1-299
(3)-D1	ED306423	Silicon Diode B1P-1	45-2-77
(3)-D2	ED306469	Zener Diode 05Z-22L	45-6-76
(3)-D2	ED307236	Zener Diode HZ22-1 (DB)	45-6-80
(3)-SW1	ES655806	△ Push SW. SDG1P (U/T, JPN)	25-5-187
(3)-SW1	ES665875	△ Push SW. SDG-1P U/L (CSA, AAL)	25-5-199
(3)-SW1	ES665807	△ Push SW. SDG-5P 5A/80A 250V (CEE, UK)	25-5-182
(3)-SW2	ES258232	△ Slide SW. S-2930 (U/T, JPN)	25-3-129
(3)-VS1	MZ283140	△ Voltage Changer 12M-60031 (U/T)	40-2-13
(3)-C1	EC249750	Elect./C. (Vert. Type) 1000 μ F 50WV	24-12-16
(3)-C6	EC551160	△ Ceramic/C. DB821 NA 0.01 μ F(Z) 1.4 KWV (U/T, JPN)	24-5-55
(3)-C6	EC294118	△ Ceramic/C. DPN6600 YM 0.01 μ F(P) 125WV (CSA, AAL)	24-5-70
(3)-C6.7	EC301320	△ MP/C. 4700PF(M) 250WV (CEE, UK)	24-9-122
(3)-8	ZS417216	Screw, pan head 3x4	
(3)-9	TC289484	SW. Joint	CM-6015
(3)-10	ZW273802	Toothed Lock Washer, M3	
(3)-11	ZS666336	Tapping Screw #2. 3x8 (Pan)	
(3)-12	ZS421806	Screw, pan head 3x8	
(3)-13	ZW516611	Nut M3	
(3)-14	EZ209215	Insulator Bush B308D (DB)	45-16-7
(3)-15	ZS379350	Screw, pan head 3x6(DB)	
(3)-16	ZS447840	Tapping Screw #2, 3x8 (BR)	

9. ILLUSTRATION OF POWER/AMP ASSEMBLY BLOCK

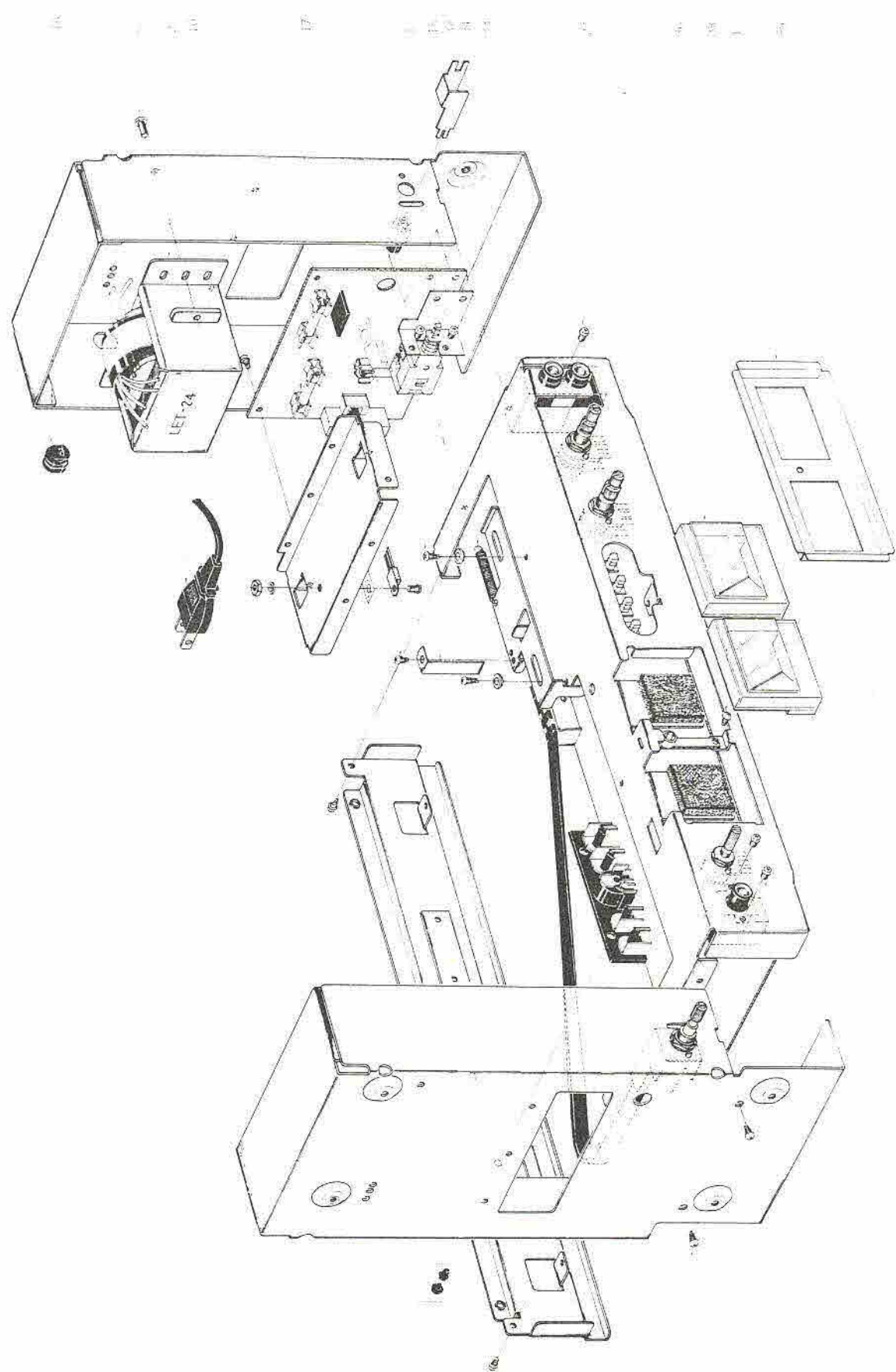

9) POWER/AMP ASSEMBLY BLOCK

Ref. No.	Parts No.	Description	Schematic No.
POWER SUPPLY BLOCK			
9-1	ZS325495	Tapping Screw #2, 3x6 (BR)	
9-2	BT306441	△ Power Trans. LET-24 (D-U/T)	38-4-573
9-3x	BT306439	△ Power Trans. LET-21 (D-JPN)	38-4-570
9-4x	BT306440	△ Power Trans. LET-22 (D-CSA, AAL)	38-4-571
9-5x	BT306442	△ Power Trans. LET-23 (D-CEE, UK)	38-4-572
9-6x	BT307232	△ Power Trans. LET-25 (DB-U/T)	38-4-574
9-7x	BT307231	△ Power Trans. LET-26 (DB-CSA, AAL)	38-4-575
9-8x	BT307233	△ Power Trans. LET-27 (DB-CEE, UK)	38-4-576
9-9	ZS413201	Screw, pan head 4x8	
9-10	EW306428	△ AC Cord (U/T)	26-3-64
9-11x	EW306427	△ AC Cord (JPN)	26-3-63
9-12x	EW305691	△ AC Cord CUL (CSA, AAL)	26-3-65
9-13x	EJ301513	△ 2P Inlet (CEE, UK)	31-1-200
9-14x	ES306430	△ Slide SW. J-S4013#01 (CEE, UK)	25-3-142
9-15x	ZS447840	Tapping Screw #2, 3x8 (BR) (CEE, UK)	
9-16	EZ631945	Strain Relief SR-4N-4 (U/T, JPN, CSA, AAL)	2-7-49
9-17	EF659507	△ Fuse 1A 250V (D-U/T, CSA, AAL) (DB-CSA)	39-1-56
9-18x	EF214727	△ Fuse SS-2 0.5A 250V (D-U/T, CSA, AAL) (DB-CSA)	39-1-56
9-19x	EF563681	△ Fuse 1A 250V (D-JPN)	39-1-50
9-20x	EF563670	△ Fuse 0.5A 250V (D-JPN)	39-1-50
9-21x	EF695766	△ Fuse (SEMKO T Type) 315mAT (D-CEE, UK)	39-1-53
9-22x	EF668474	△ Fuse (SEMKO T Type) 400mAT (D-CEE, UK)	39-1-53
9-23x	EF258344	△ Fuse (SEMKO T Type) 800mAT (DB-CEE, UK)	39-1-53
9-24x	EF593706	△ Fuse (SEMKO T Type) 500mAT (DB-CEE, UK)	39-1-53
9-25x	EF258344	△ Fuse (SEMKO T Type) 800mAT (DB-CEE, UK)	39-1-53
AMP ASSEMBLY BLOCK			
9-26x	ZW273802	Toothed Lock Washer, M3	
9-27	ZS422076	Screw, pan head 3x5	
9-28	EM306433	VU Meter D18C45R	46-1-202
9-29x	EM306432	VU Meter D18C43R (D-JPN)	46-1-204
9-30x	EM306434	VU Meter D18C44R (BL)	46-1-203
9-31	ZW263946	Nylon Rivet 4x5	2-7-57
9-32	ZG306242	Plate Spring	LE-5706
9-33	ZG644848	PR Spring	CA-1081
9-34	ZW306252	Graduated Washer	LE-6743
9-35	ML306265	Meter Base (B) (GX-4000D)	LE-6706,6707
LED P.C BOARD BLOCK			
9-36	ED249377	LED GL-3AR1	45-15-14
9-37x	ED283138	LED GL-3PG1 (DB)	45-15-15

10. PHOTO OF FINAL ASSEMBLY BLOCK

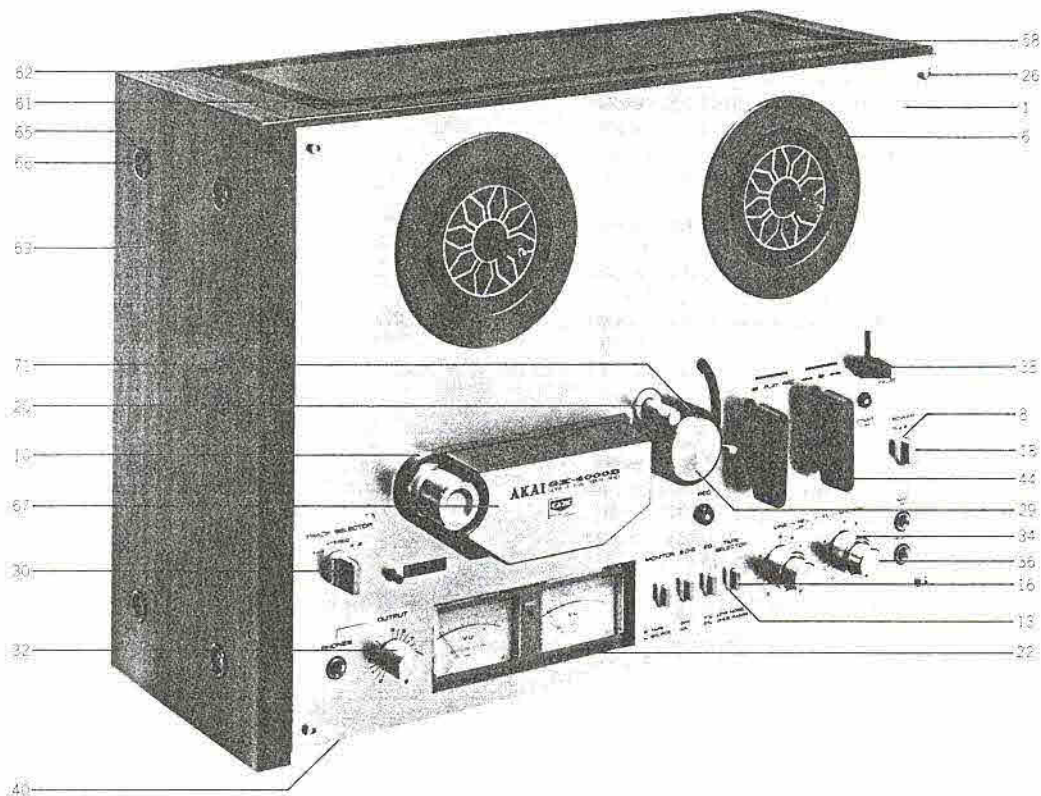

10) FINAL ASSEMBLY BLOCK

Ref. No.	Parts No.	Description	Schematic No.	Ref. No.	Parts No.	Description	Schematic No.
FRONT PANEL BLOCK				10-26	ZS613901	Panel Screw	CW-6031
10-1	BD306566	Front Panel Block Comp. GX-4000D		10-27x	ZS306435	Panel Screw (C)	CW-6031
10-2x	BD306567	Front Panel Block Comp. GX-4000D-BL		10-28x	MH306232	Head Cover Prop	LE-6731
10-3x	BD307116	Front Panel Block Comp. GX-4000DB		10-29	SK583132	Pinch Roller Cap (B) Part LE-3	MS-6020
10-4x	BD307117	Front Panel Block Comp. GX-4000DB-BL		10-30	SK306226	Knob (B)	LE-6727
10-5x	ZW306646	Nylon Rivet 3x3.5 (Nylon)	2-7-54	10-31x	SK306227	Knob (B-BL)	LE-6727
10-6	SZ306214	Reel Table Ring	LE-6738	10-32	SK306333	Knob (A) LE-8	LE-6725
10-7x	SZ306215	Reel Table Ring (BL)	LE-6738	10-33x	SK306334	Knob (A-BL) LE-8	LE-6725
10-8	SE306216	Escutcheon	LE-6735	10-34	SK306335	Double Knob (Lower) LE-8	LE-6723
10-9x	SE306217	Escutcheon (BL)	LE-6735	10-35x	SK306336	Double Knob (Lower-BL) LE-8	LE-6723
10-10	SC306257	Head Cover Base	LE-6711	10-36	SK306337	Double Knob (Upper) LE-8	LE-6722
10-11x	SC306258	Head Cover Base (BL)	LE-6711	10-37x	SK306338	Double Knob (Upper-BL) LE-8	LE-6722
10-12x	ZW260370	Nylon Rivet 3.4x5.5	2-7-56	10-38	SK259345	Pause Knob (C) Part MU-3	MR-612
10-13	SZ306222	Button Housing	LE-6732	10-39x	SK287280	Pause Knob (D) Part MU-3(BL)	MR-612
10-14x	SZ306223	Button Housing (BL)	LE-6732	10-40	SP306266	Lower Cover (A)	LE-6708
10-15x	ZG306233	Spring	LE-6734	10-41x	SP306267	Lower Cover (B) (AAL)	LE-6708
10-16	SB306220	Button (B)	LE-6733	10-42x	SA306240	Rubber Foot (B)	LE-6740
10-17x	SB306221	Button (B-BL)	LE-6733	10-43x	ZS306463	S Tight Screw, 3x8 (Pan) w/flange	
FINAL ASSEMBLY BLOCK				10-44	SK306316	Mecha Knob MU-3	MU-6303
10-18	SB306218	Button (A)	LE-6736	10-45x	ZS253405	Mecha Knob Screw SWRM-3	7-1-46
10-19x	SB306219	Button (A-BL)	LE-6736	10-46x	SK287291	Mecha Knob (B) Part MU-3 (BL)	MU-6303
10-20	MZ301585	Metal Cap	LE-6607	10-47x	SP306278	Rear Panel (D) (D-U/T)	LE-6716.6804
10-21x	MZ306436	Metal Cap (BL)	LE-6607	10-48x	SP306275	Rear Panel (A) (D-JPN)	LE-6716.6801
10-22	ML306265	Meter Base (B)	LE-6706.6707	10-49x	SP306277	Rear Panel (C) (D-CSA)	LE-6716.6803
10-23x	ML307217	Meter Base (A) (DB)	LE-6706.6707	10-50x	SP306276	Rear Panel (B) (D-AAL)	LE-6716.6802
10-24x	ML306448	Meter Base (B-BL)	LE-6706.6707	10-51x	SP306279	Rear Panel (E) (D-CEE, UK)	LE-6716.6805
10-25x	ML307218	Meter Base (A-BL) (DB)	LE-6706.6707	10-52x	SP307223	Rear Panel (H) (DB-U/T)	LE-6716.6719
				10-53x	SP307222	Rear Panel (G) (DB-CSA)	LE-6716.6718
				10-54x	SP307221	Rear Panel (F) (DB-AAL)	LE-6716.6717
				10-55x	SP307224	Rear Panel (I) (DB-CEE, UK)	LE-6716.6720

When ordering parts, please describe Parts Number, Description, and Model Number in detail.

Ref. No.	Parts No.	Description	Schematic No.
10-56x	ZS297641	Tapping Screw #2, 3x8 (Bind) W=10	
10-57x	ZS325495	Tapping Screw #2, 3x6 (BR)	
10-58	SP306262	Upper Cover (A)	LE-6703
10-59x	SP306263	Upper Cover (B) (AAL)	LE-6703
10-60x	ZW305006	Nylon Rivet 4x5	2-7-58
10-61	SZ480712	Dust Cover Pin	LE-6024
10-62	ZS537006	Screw, binding head 4x8	
10-63	SP306273	Side Board	LE-6701
10-64x	SP306274	Side Board (BL)	LE-6701
10-65	ZW548010	Spot Facing Washer	MU-6028
10-66	ZS328195	Screw, binding head 4x20	
10-67	SC306564	Head Cover Assy GX-4000D	LE-6807
10-68x	SC306565	Head Cover Assy GX-4000D-BL	LE-6807
10-69x	SC307118	Head Cover Assy GX-4000DB	LE-6807
10-70x	SC307119	Head Cover Assy GX-4000DB-BL	LE-6807
10-71	MP204794	Pinch Roller Part LS	3A-348
10-72x	ZW376391	Washer (Polyslider) D6.1x10x0.13t	
10-73x	ZS413201	Screw, pan head 4x8	

11. LIST OF INTERCHANGEABLE SEMICONDUCTORS

If, while servicing, the original parts cannot be obtained, the interchangeable parts listed below can be substituted.

Original Parts			Interchangeable Parts	
Description	Parts No.	Utilizing P.C Board	Description	Parts No.
2SC458 (B) (C)	ET368021	LE-5701 (A)	2SC839 (E) (F) 2SC1312S (G) (H)	ET458065 ET603257
2SC458LG (C) (D)	ET391768	LE-5701 (A) LE-5801 (A)	2SC693U (F) 2SC1312R (G) (H)	ET315472 ET517263
2SC711 (G)	ET399870	LE-5701 (A)	2SC536 (G) (H) 2SC1647 (S) (E) (U)	ET403391 ET621270
2SC945L (Q) (P) 2SC945L (R)	ET639437 ET398788	LE-5701 (A) LE-5801 (A)	2SC536 (F) (G) (H) 2SC711 (E) (F) (G) (H)	ET634893 ET619727
2SC1061 (B) (C)	ET375603	LE-5701 (A) LE-5702	2SD313 (D) (E) (F) 2SD361 (D) (E)	ET522911 ET537300
2SC1312S (G) 2SC1312S (G) (H)	ET663243 ET603257	LE-5701 (A)	2SC458LG (C) (D)	ET491768
2SC1815 (Y) (GR)	ET307234	LE-5702		
2SD361 (D) (E)	ET537300	LE-5802	2SD234 (O) (Y)	ET393568
2SK30A (Y) (GR)	ET552870	LE-5801 (A)		
2SK68 (M) (N)	ET301464	LE-5701 (A)		
1S2473 1S2473VE	ED624903 ED560913	LE-5801 (A) LE-5701 (A)	1S1588	ED557447
1S188AM	ED562386	LE-5801 (A)	1N34A 1N60	ED219464 ED428264
1N34A	ED219464	LE-5701 (A)	1S188AM 1N60	ED562386 ED428264
10D1	ED224526	LE-5801 (A)	1N4002	ED511907
05Z22L	ED306469	LE-5802		
HZ12B-2	ED310387	LE-5701 (A)		
HZ22-1	ED307236	LE-5702		
BIP-1	ED306423	LE-5802 LE-5702		
GL-3PG1	ED283138	LE-5701 (B)		
GL-3ARI	ED249377	LE-5701 (B) LE-5801 (B)	SR105D	ED283138

INDEX

Parts No.	Ref. No. & Symbol No.	Parts No.	Ref. No. & Symbol No.	Parts No.	Ref. No. & Symbol No.	Parts No.	Ref. No. & Symbol No.	Parts No.	Ref. No. & Symbol No.
BA306532	(1)-1	ED306423	(3)-D1	ET307234	(3)-TR2	MR269763	7-52	SK306334	10-33x
BA306543	(3)-1	ED306469	(3)-D2	ET368021	(2)-TR8,9	MR300644	3-14	SK306335	10-34
BA306544	(3)-2	ED307236	(3)-D2	ET375603	(2)-TR10	MR611976	3-13	SK306336	10-35x
BA306545	(3)-3	ED310387	(2)-D6	ET375603	(3)-TR1	MS244708	5-3	SK306337	10-36
BA306547	(3)-4	ED560913	(1)-D4	ET391768	(1)-TR1to3	MS306208	4-5	SK306338	10-37x
BA307124	(3)-5	ED562386	(1)-D1.2	ET391768	(1)-TR6to9	MS582906	7-53	SK583132	10-29
BA307125	(3)-6	ED562386	(1)-D5.6	ET391768	(1)-TR14to16	MT222366	4-11	SP306262	10-58
BA307126	(3)-7	ED624903	(1)-D3	ET391768	(1)-TR19to22	MT252112	4-3x	SP306263	10-59x
BA307132	(2)-1	ED624903	(1)-D8	ET391768	(2)-TR1	MT252123	4-18	SP306266	10-40
BD306566	10-1	ED624903	(2)-D3to5	ET391768	(2)-TR5	MT255870	4-17	SP306267	10-41x
BD306567	10-2x	EF214727	9-18x	ET399870	(2)-TR4	MT255971	4-20	SP306273	10-63
BD307116	10-3x	EF258344	9-23x	ET398788	(1)-TR12,13	MT255982	4-21x	SP306274	10-64x
BD307117	10-4x	EF258344	9-25x	ET399846	(1)-TR11	MT255993	4-22	SP306275	10-48x
BF205075	5-1x	EF563670	9-20x	ET399846	(1)-TR24	MT306237	4-4	SP306276	10-50x
BH306536	2-1x	EF563681	9-19x	ET537300	(3)-TR1	MT438581	4-28	SP306277	10-49x
BL311453	7-1	EF593706	9-24x	ET552870	(1)-TR25,26	MT438592	4-24x	SP306278	10-47x
BM306529	3-1	EF659507	9-17	ET603257	(2)-TR2	MT438625	4-27	SP306279	10-51x
BR306554	4-2x	EF668474	9-22x	ET603257	(2)-TR6	MT438636	4-23x	SP307221	10-54x
BR306555	4-1x	EF695766	9-21x	ET639437	(1)-TR4,5	MT458943	4-7	SP307222	10-53x
BS480352	6-1x	EI301463	(2)-IC1.2	ET639437	(1)-TR10	MT516565	4-6	SP307223	10-52x
BT306439	9-3x	EI306141	(1)-IC1	ET639437	(1)-TR17,18	MT676383	4-30	SP307224	10-55x
BT306440	9-4x	EI306141	(2)-IC3	ET639437	(1)-TR23	MV269965	3-8x	SZ276816	2-5
BT306441	9-2	EJ249333	(1)-P901.902	ET639437	(2)-TR11,12	MV269965	5-13	SZ306214	10-6
BT306442	9-5x	EJ249333	(2)-P1.2	ET663243	(2)-TR3	MV270066	6-15	SZ306215	10-7x
BT307231	9-7x	EJ283094	(1)-J2	EV305635	(1)-VR1	MV639630	7-85	SZ306222	10-13
BT307232	9-6x	EJ301513	9-13x	EV305635	(1)-VR3,4	MY270055	5-14	SZ306223	10-14x
BT307233	9-8x	EJ302984	(1)-P903	EV305635	(1)-VR6	MZ206515	6-24	SZ465377	7-83
EC249750	(3)-C1	EJ302984	(2)-P3	EV305636	(1)-VR2	MZ210126	3-12	SZ480712	10-61
EC250672	(2)-C37	EJ306289	(1)-J1	EV305636	(1)-VR5	MZ217271	6-16	TC289484	(3)-9
EC294118	(3)-C6	EJ306289	(2)-J1	EV306293	(1)-VR7,8	MZ217708	7-25	ZG206144	2-23
EC301320	7-71x	EJ306290	(1)-J3	EV306293	(2)-VR1	MZ217855	7-57	ZG208091	7-61
EC301320	(3)-C6,7	EJ306290	(2)-J3	EV306446	(1)-VR9	MZ256814	7-64x	ZG217866	7-58
EC303025	(2)-C41	EJ306985	(2)-J2	EV306446	(2)-VR6	MZ283140	(3)-VS1	ZG227417	7-54
EC305680	(1)-C21	EJ309102	2-34x	EV306981	(2)-VR2	MZ301585	5-16	ZG227452	7-36
EC305680	(1)-C68	EJ309102	2-32x	EV464220	(2)-VR4	MZ301585	10-20	ZG227485	6-28
EC306419	(1)-C26	EJ309103	2-33x	EV478686	(2)-VR5	MZ306436	5-17x	ZG227542	4-13x
EC306419	(1)-C73	EM306432	9-29x	EV520806	(2)-VR3	MZ306436	10-21x	ZG227553	4-12
EC306420	(1)-C15	EM306433	9-28	EW305691	9-12x	MZ312524	7-37	ZG227575	7-19
EC306420	(1)-C62	EM306434	9-30x	EW306427	9-11x	MZ327341	6-8	ZG227586	6-9
EC306420	(2)-C30	ER300820	7-70x	EW306428	9-10	MZ327352	6-10	ZG257095	7-23
EC306424	3-19	ER305722	(1)-R74,75	EZ209215	(3)-14	MZ446635	5-6	ZG260717	7-2x
EC306425	3-21x	ER306416	(1)-R76	EZ335204	3-2x	MZ585887	7-72	ZG270358	7-48
EC306438	(1)-C30	ER306462	3-23	EZ631945	9-16	MZ585900	5-8	ZG290384	7-34
EC306438	(1)-C100,101	ER306961	(2)-R95	MB256601	5-11	MZ610301	6-5	ZG306233	10-15x
EC306438	(1)-C103	ER306962	(2)-R94	MB406168	7-76x	MZ610457	7-55	ZG306241	4-8
EC306438	(2)-C35	ER307182	(2)-FL2	MC479968	7-67	MZ628211	7-28	ZG306242	9-32
EC306470	(1)-C39	ER309119	(2)-FL3	MH244710	5-7	MZ675887	5-5	ZG312928	2-13
EC306471	(1)-C2	ER309120	(2)-FL1	MH258581	6-23	HA306210	2-26	ZG469427	7-15
EC306471	(1)-C22	ER450786	7-69	MH289168	7-60	HA306211	2-18	ZG644848	9-33
EC306471	(1)-C49	EO301448	(2)-L2	MH306232	10-28x	HE384693	2-29	ZS201767	7-39
EC306471	(1)-C61	EO301711	(2)-L1	MI241413	7-20	HP307087	2-25	ZS217877	6-20
EC306471	(1)-C69	EO306417	(1)-L2	MI675450	7-44	HR307088	2-17	ZS223233	7-43
EC306474	(1)-C95	EO306417	(1)-L7	ML305715	6-25	HZ274162	2-6	ZS253405	10-45x
EC306980	(1)-C3	EO306418	(1)-L1	ML306265	9-35	HZ306246	2-27	ZS284231	5-15
EC306980	(1)-C23	EO306418	(1)-L6	ML306265	10-22	HZ306249	2-20	ZS297641	10-56x
EC306980	(1)-C50	EO383365	(1)-L5	ML306332	2-11	HZ317597	2-3	ZS306435	10-27x
EC306980	(1)-C70	EO383365	(2)-T1	ML306448	10-24x	HZ410984	2-30	ZS306463	10-43x
EC306980	(2)-C43	EO482905	(1)-L3	ML307217	10-23x	SA306240	10-42x	ZS323728	3-22
EC306986	(2)-C3	EO482905	(1)-L8	ML307218	10-25x	SA311202	7-77x	ZS323728	7-24
EC306987	(2)-C38	EO482905	(2)-L3.4	ML479957	7-56	SB306218	10-18	ZS325495	7-7x
EC306988	(2)-C44	EO624857	(1)-VL1to4	ML663355	7-12	SB306219	10-19x	ZS325495	(2)-2
EC307167	(2)-C1	ES258232	(3)-SW2	ML663401	7-17	SB306220	10-16	ZS325495	9-1
EC307167	(2)-C36	ES306291	(1)-SW1	ML663761	7-27	SB306221	10-17x	ZS325495	10-57x
EC307243	(2)-C5	ES306292	(1)-SW3	ML663805	7-41	SB625004	7-75	ZS327835	2-21
EC309122	3-20x	ES306292	(2)-SW5	ML663816	7-51	SC306257	10-10	ZS328195	10-66
EC551160	(3)-C6	ES306422	(1)-SW4	ML663827	7-46	SC306258	10-11x	ZS379350	2-2
EC558202	(1)-VC1.2	ES306430	9-14x	ML668687	7-35	SC306564	10-67	ZS379350	4-35
EC558202	(2)-VC1.2	ES306460	7-65x	ML668700	7-33	SC306565	10-68x	ZS379350	(3)-15
EC604102	(2)-C2	ES306982	(2)-SW1	ML676001	2-12	SC307118	10-69x	ZS413177	5-12
EC604102	(2)-C58	ES307163	(2)-SW3	ML674357	7-30	SC307119	10-70x	ZS413201	6-6
EC619650	(2)-C21	ES307180	7-66x	ML675854	6-17	SE306216	10-8	ZS413201	7-5x
EC619650	(2)-C57	ES316934	6-2	MP204794	10-71	SE306217	10-9x	ZS413201	9-9
EC621257	(1)-C12	ES369865	6-3	MR217203	6-18	SH306225	7-86	ZS413201	10-73x
EC621257	(1)-C59	ES403727	7-68	MR217203	6-26	SK259345	10-38	ZS413234	7-26
EC661972	(2)-C77	ES494302	(1)-SW2	MR217203	7-13	SK287280	10-39x	ZS414044	7-6
ED219464	(2)-D1.2	ES494302	(2)-SW2	MR217214	7-14	SK287291	10-46x	ZS417150	3-17
ED219464	(2)-D7,8	ES655806	(3)-SW1	MR251460	4-9	SK306226	10-30	ZS417150	7-29
ED224526	(1)-D7	ES665807	(3)-SW1	MR252044	4-10	SK306227	10-31x	ZS417216	2-10
ED249377	9-36	ES665875	(3)-SW1	MR252055	4-19	SK306316	10-44	ZS417216	7-31
ED283138	9-37x	ET301464	(2)-TR7	MR256083	4-34	SK306333	10-32	ZS417216	(3)-8

INDEX

Parts No.	Ref. No. & Symbol No.	Parts No.	Ref. No. & Symbol No.	Parts No.	Ref. No. & Symbol No.	Parts No.	Ref. No. & Symbol No.	Parts No.	Ref. No. & Symbol No.
ZS419670	2-24	ZW413267	6-22						
ZS419670	7-73	ZW413267	7-11x						
ZS421806	2-9	ZW413278	5-10						
ZS421806	4-36x	ZW420682	2-14						
ZS421806	(3)-12	ZW432347	6-21						
ZS422076	3-16x	ZW432347	7-18						
ZS422076	3-18	ZW437804	4-31						
ZS422076	7-74	ZW447208	5-4						
ZS422076	9-27	ZW516611	2-8						
ZS424056	3-11	ZW516611	(3)-13						
ZS424056	7-10	ZW548010	10-65						
ZS427026	3-10	ZW553972	4-22						
ZS427037	3-9	ZW601075	7-78x						
ZS444330	2-28	ZW649991	7-80x						
ZS447840	7-9x								
ZS447840	(3)-16								
ZS447840	9-15x								
ZS460440	2-19								
ZS464692	2-16								
ZS477876	2-31								
ZS537006	10-62								
ZS558101	2-4								
ZS558101	6-4								
ZS593177	7-38								
ZS600816	3-15								
ZS600816	7-8x								
ZS608275	3-24								
ZS608321	7-63								
ZS613901	10-26								
ZS666336	(3)-11								
ZS687126	5-2								
ZW231693	4-25								
ZW231805	7-84								
ZW259942	7-32								
ZW260010	7-59								
ZW260021	4-26								
ZW260043	4-29x								
ZW260054	4-14								
ZW260054	7-22								
ZW260065	4-15x								
ZW260076	6-12x								
ZW260098	4-16x								
ZW260111	6-13x								
ZW260111	7-49x								
ZW260133	6-7								
ZW260133	7-62x								
ZW260144	6-11x								
ZW260370	10-12x								
ZW263946	9-31								
ZW269785	2-15								
ZW270000	4-33								
ZW273802	2-7								
ZW273802	(3)-10								
ZW273802	9-26x								
ZW273914	7-3x								
ZW283465	3-3x								
ZW283476	3-4x								
ZW283487	3-5x								
ZW283498	3-6x								
ZW283500	3-7x								
ZW283803	7-42x								
ZW285862	7-81								
ZW285873	5-9								
ZW290283	6-19								
ZW290283	6-27								
ZW290283	7-16								
ZW290294	7-21								
ZW305006	10-60x								
ZW306252	9-34								
ZW306464	2-22								
ZW306646	10-5x								
ZW321906	7-45x								
ZW322110	6-14x								
ZW322525	7-79x								
ZW326463	7-82								
ZW369595	7-40x								
ZW376380	7-50x								
ZW376391	7-47								
ZW376391	10-72x								
ZW413188	7-4								

CR713B

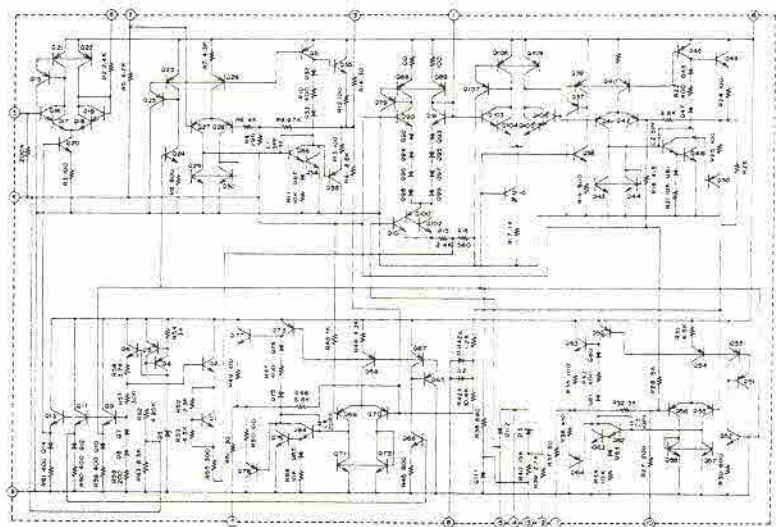

LA4170

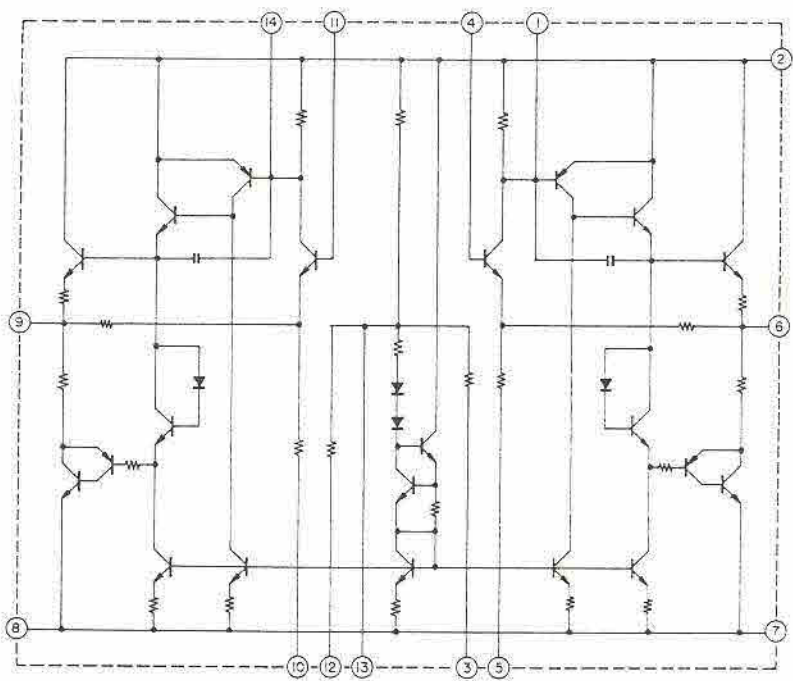

LA4170

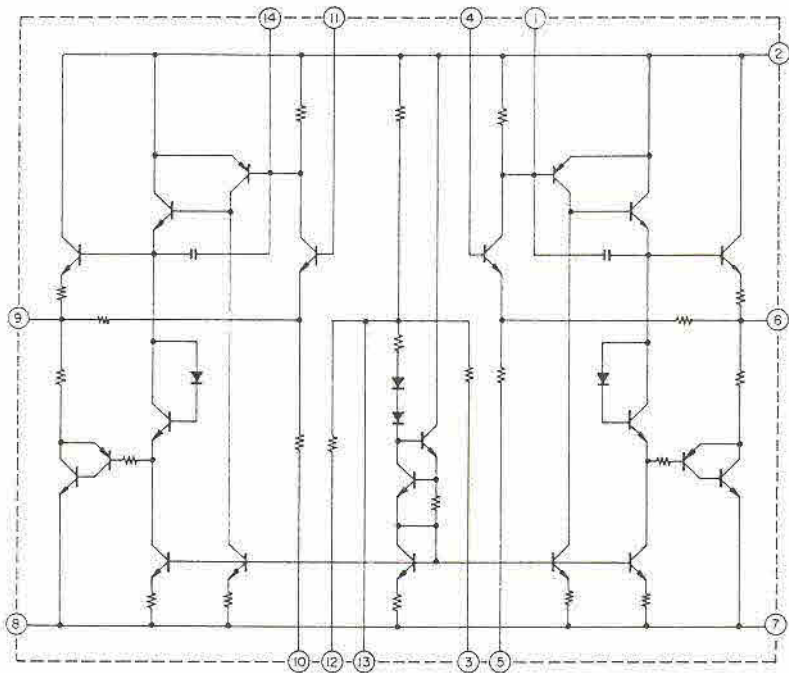

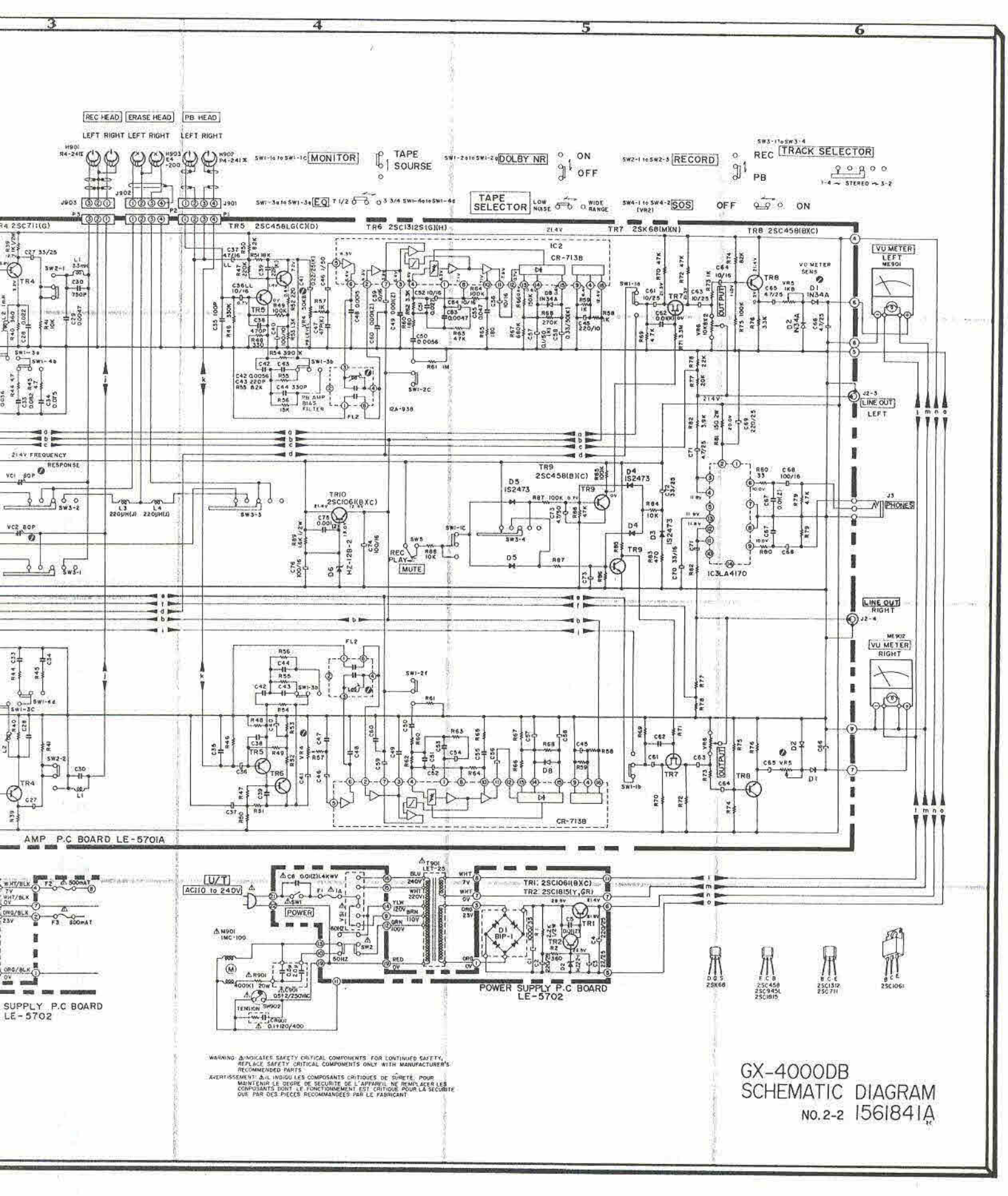

WARNING: INDICATE SAFETY CRITICAL COMPONENTS FOR CONTINUED SAFETY.
 REPLACE SAFETY CRITICAL COMPONENTS ONLY WITH MANUFACTURER'S
 RECOMMENDED PARTS.
 AVERTISSEMENT: A LI INDICOU LES COMPOSANTS CRITIQUES DE SURETE. POUR
 MAINTENIR LE DEGRE DE SECURITE DE L'APPAREIL, NE REMPLACEZ LES
 COMPOSANTS DONT LE FONCTIONNEMENT EST CRITIQUE POUR LA SECURITE
 QUE PAR DES PIECES RECOMMANDEES PAR LE FABRICANT.

GX-4000DB
 SCHEMATIC DIAGRAM
 No.2-2 1561841A

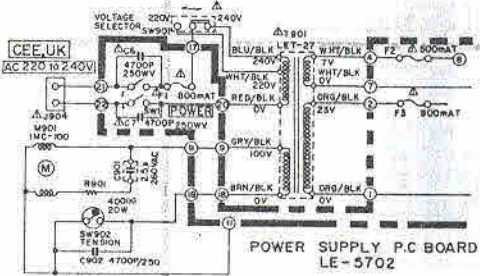
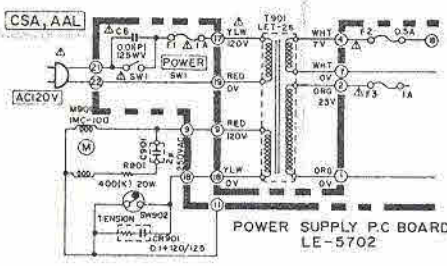
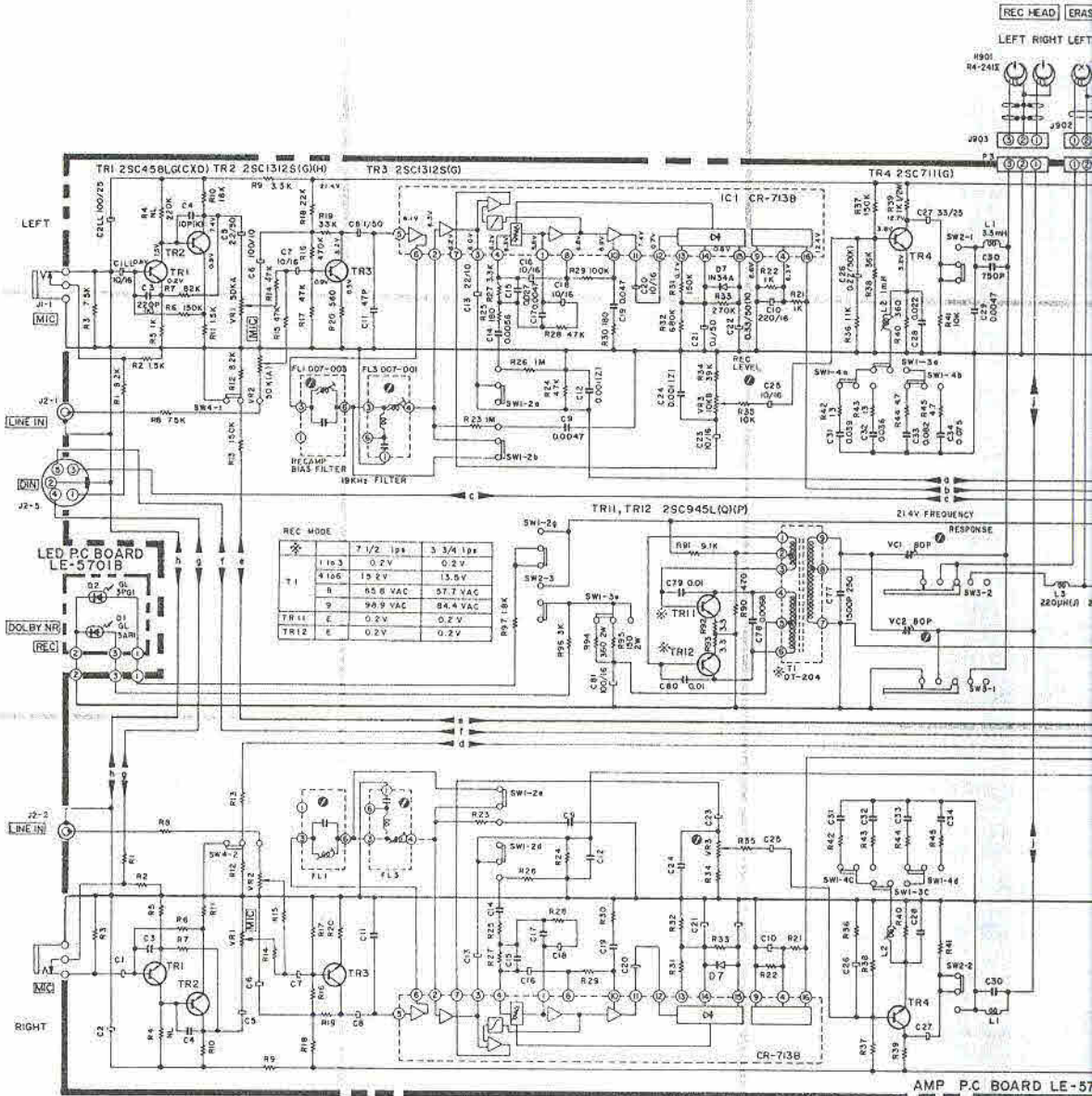

UNLESS OTHERWISE SPECIFIED;
 ALL RESISTORS IN OHMS (1/4W)
 ALL CAPACITORS IN µF (50VDC)
 2 (LL)-LOW LEAKAGE CAPACITORS
 3 (NL)-NOISE LESS RESISTORS
 4 POWER TRANSFORMER IS DIFFERENT
 ACCORDING TO AREA

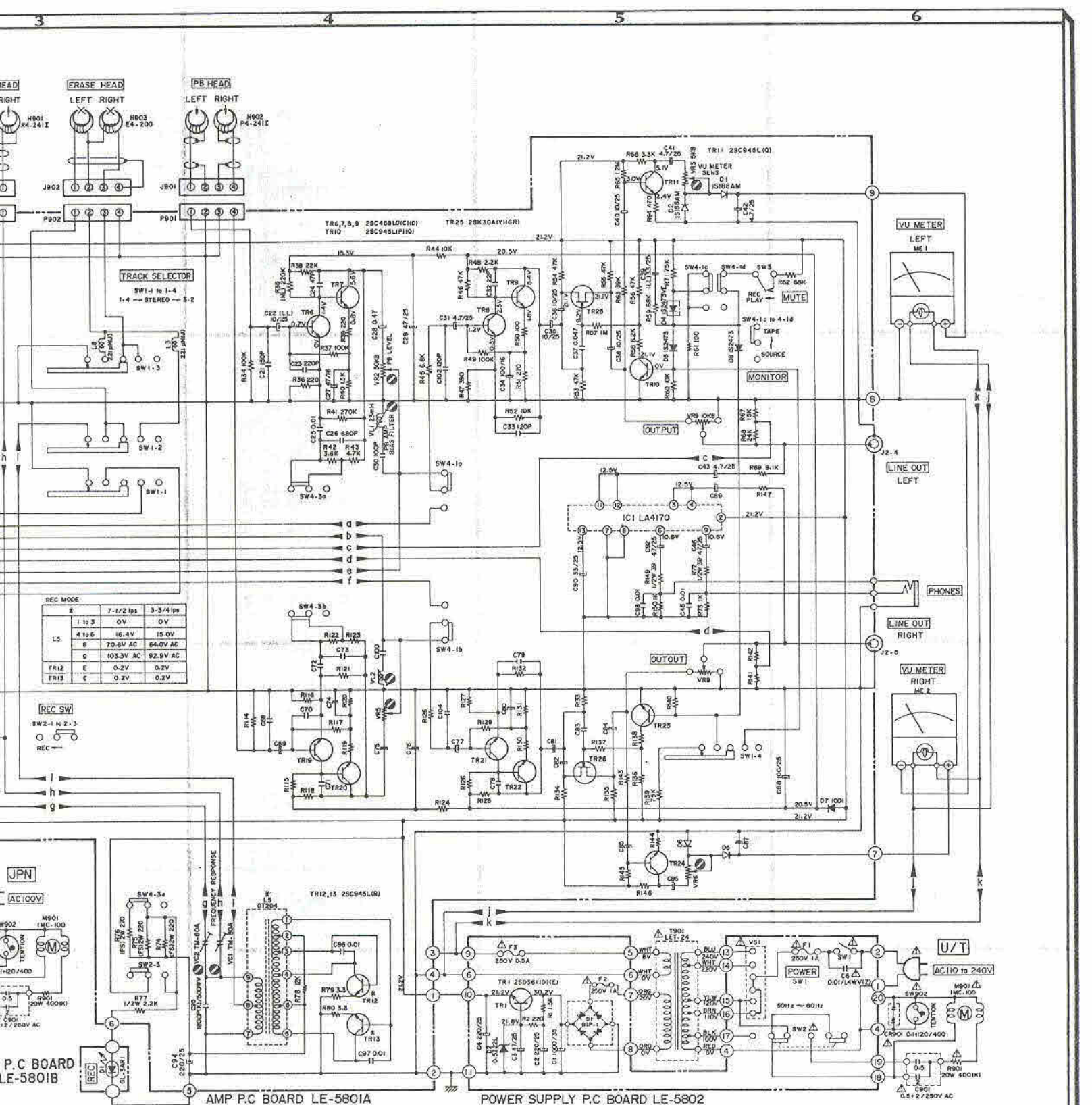

WARNING: Δ INDICATES SAFETY CRITICAL COMPONENTS. FOR CONTINUED SAFETY, REPLACE SAFETY CRITICAL COMPONENTS ONLY WITH MANUFACTURER'S RECOMMENDED PARTS

ATTENTION: Δ IL INDIQUE LES COMPOSANTS CRITIQUES DE SÛRETÉ. POUR MAINTENIR LE DEGRÉ DE SÛRETÉ DE L'APPAREIL NE REMPLACER LES COMPOSANTS DONT LE FONCTIONNEMENT EST CRITIQUE POUR LA SÛRETÉ QUE PAR DES PIÈCES RECOMMANDÉES PAR LE FABRICANT

NOTE

1. UNLESS OTHERWISE SPECIFIED ALL RESISTORS IN OHMS (1/4W (J)) ALL CAPACITORS IN μF (50WV (J))
2. (L) = LOW LEAKAGE CAPACITORS
3. (N) = NOISE LESS RESISTORS
4. POWER TRANSFORMER IS DIFFERENT ACCORDING TO AREA
5. [] MARKED PART (R13, R93, D4) ARE LOCATED ON SW. P.C. BOARD LE-5801C

GX-4000
SCHEMATIC DIAGRAM
No. 2-1 1561840A

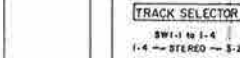
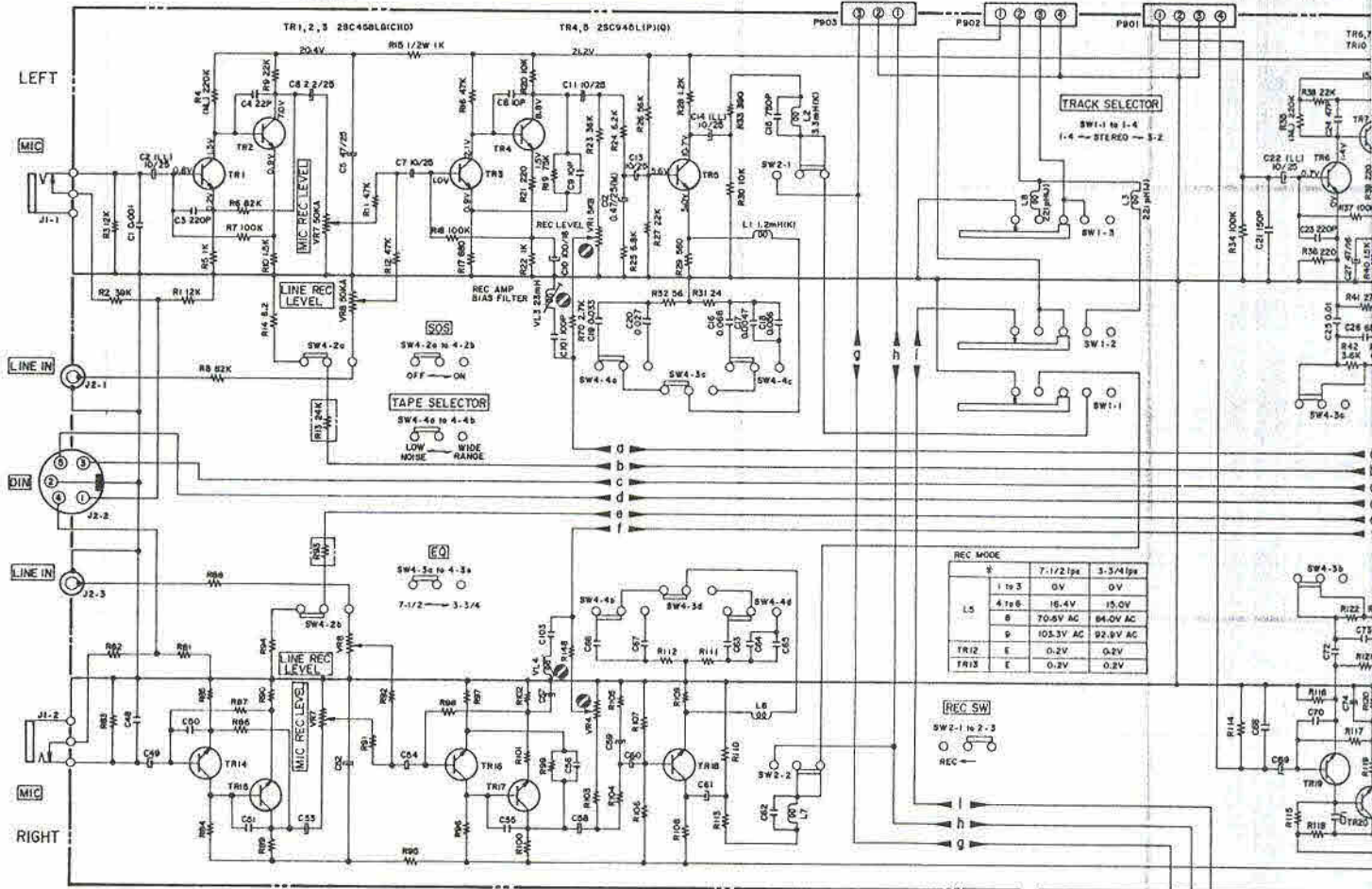
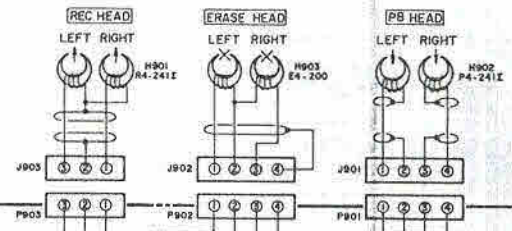

	1 to 3	7-1/2 ips	3-3/4 ips
L5	0V	0V	0V
8	16.4V	15.0V	
9	70.5V AC	64.0V AC	
TR12	E	0.2V	0.2V
TR13	E	0.2V	0.2V

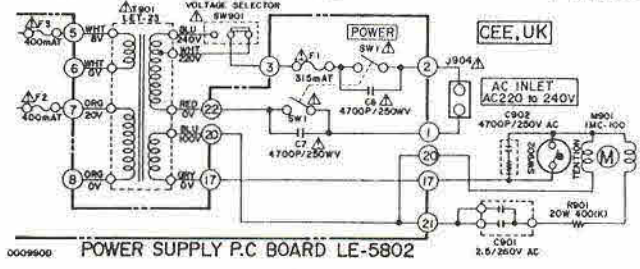
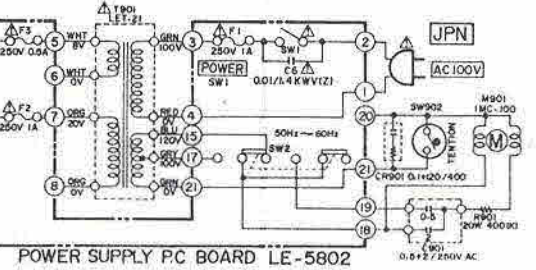
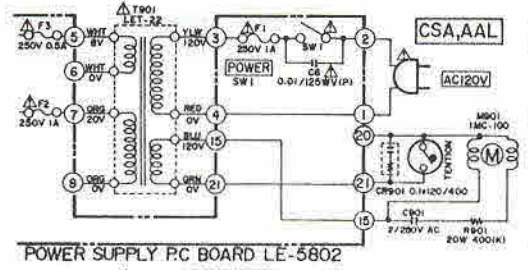

LED P.C BOARD LE-5801B

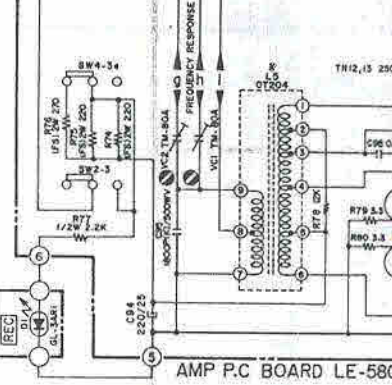

WARNING: Δ INDICATES SAFETY CRITICAL COMPONENTS. FOR CONTINUED SAFETY, REPLACE SAFETY CRITICAL COMPONENTS ONLY WITH MANUFACTURER'S RECOMMENDED PARTS.
 AVERTISSEMENT: Δ IL INDIQUE LES COMPOSANTS CRITIQUES DE SÛRETÉ. POUR MAINTENIR LE DEGRÉ DE SÛRETÉ DE L'APPAREIL, NE REMPLACER LES COMPOSANTS DONT LE FONCTIONNEMENT EST CRITIQUE POUR LA SÛRETÉ QUE PAR DES PIÈCES RECOMMANDÉES PAR LE FABRICANT.