



UNSER WEG

Unser Weg beginnt im Jahre 1946. Die Brüder Kurt und Bruno Waasner gründen die Elektromechanischen Werkstätten in Schlüsselfeld.

Schon sechs Jahre später muss die Firma wegen räumlicher Engpässe nach Forchheim umsiedeln. Die Schwerpunkte lagen bereits zu dieser Zeit in der Entwicklung und Produktion von Kernblechen für Transformatoren und Elektromotoren.

OUR WAY

Our way begins in 1946. Brothers Kurt and Bruno Waasner establish the Elektromechanischen Werkstätten in Schlüsselfeld.

Only six years later, the company has outgrown its premises and moved to Forchheim. Even in those days, major emphasis was placed on the development and production of core laminations for transformers and electric motors.

AUF DEM WEG ZUR QUALITÄT IST MAN NIEMALS AM ZIEL

MESS- UND PRÜFGERÄTE (AUSZUG)

- Messmaschine (taktil und optisch)
- Zug- und Druckprüfmaschine
- Messprojektor
- Härteprüfgerät
- Schichtdickenmessgerät
- Messgerät für elektromagnetische Eigenschaften

QUALITY STANDARD - THE CUSTOMER ALONE DECIDES

MEASURING AND TESTING EQUIPMENT (IN PARTS)

- Measuring machine (tactile and optical)
- Tension and compression testing machine
- Measuring projector
- Hardness measuring system
- Measuring machine for coating thickness
- Power and energy meter



FIRMENGESCHICHTE

1946	Kernbleche für Transformatoren und Elektromotoren
1952	Umzug in neues Werk in Forchheim
1964	Drehstrombleche
1968	Steckernbleche
1971	Neubau Werkzeugbau
1972	Schnitt- und Ringbandkerne
1978	Neubau Bandspalten und SBK
1990	Neubau Hochregallager und Verwaltung
2000	Backlackpakete
2001	Erweiterung Stanzpaketierkonzepte
2003	Baugruppen für Automobilindustrie
2008	Produktionsbeginn Werk Süd, Läufer Druckguss
2013	Laserschweißen von dünnem, hoch siliziertem Elektrolech

UNTERNEHMENSPHILOSOPHIE

- Der Mensch steht im Mittelpunkt
- Das Wissen und Können unserer Mitarbeiter/ -innen, ihr eigenverantwortliches Handeln, ihre Motivation und ihr Leistungswille sind Garant für den langjährigen Erfolg des Unternehmens
- Der Mensch bestimmt die Qualität...

COMPANY HISTORY

1946	Core laminations for transformers and motors
1952	Relocation to new plant in Forchheim
1964	3-phase laminations
1968	Transformer core laminations
1971	New construction of tooling department
1972	Split tape and toroidal cores
1978	New construction of slit material, split tape and toroidal core departments
1990	Construction of high-bay warehouse and administration building
2000	Bonding varnish stacks
2001	Extension of interlocking concepts
2003	Components for automotive industry
2008	Start of production plant south, start of die-casting production
2013	Laser welding of thin, highly silicated electrical steel

PEOPLE AS THE FOCUS OF ATTENTION

- People form the focus of attention of our corporate philosophy
- The knowledge and skill of our employees, their responsible actions, their motivation and their willingness to perform represent the guarantees for the long-term success of the company
- Quality is determined by people...



INHALTSVERZEICHNIS/ INDEX

1. KERNBLECHE/ CORE LAMINATIONS EI - KERNBLECHE/ EI - CORE LAMINATIONS EI - KERNBLECHE (MIT LUFTSPALT)/ EI - CORE LAMINATIONS (WITH AIR-GAP) WEI - KERNBLECHE/ WEI - CORE LAMINATIONS EE - KLEINKERNBLECHE/ EE - MINIATURE CORE LAMINATIONS EK - KERNBLECHPAKETE/ EK - CORE LAMINATION STACKS	S.7 - S.15
2. STECKKERNBLECHE/ READY-CORE LAMINATIONS EI../2R EE../2R M../2R WUI../2R	S.17 - S.21
3. KERNBLECHE/ CORE LAMINATIONS UI - KERNBLECHE/ UI - CORE LAMINATIONS 3UI - DREHSTROMBLECHE/ 3UI - PHASE LAMINATIONS	S.23 - S.25
4. STREIFENBLECHE/ STRIP LAMINATIONS STREIFENBLECHE/ STRIP LAMINATIONS	S.27 - S.29
5. MAGNETISCHE UND TECHNOLOGISCHE EIGENSCHAFTEN/ MAGNETIC AND TECHNOLOGICAL PROPERTIES MAGNETISCHE UND TECHN.EIGENSCHAFTEN/MAGNETIC AND TECHN. PROPERTIES	S.31 - S.33
6. SCHNITTBANDKERNE/ SPLIT TAPE CORES SM - REIHE/ SM - LINE SE- REIHE/ SE - LINE SU- REIHE/ SU - LINE S3U - REIHE/ S3U - LINE SG - REIHE/ SG - LINE SONDERFORMEN/ SPECIAL SPLIT TAPE CORE DESIGNS GARANTIE FÜR SCHNITTBANDKERNE/ GUARANTEES FOR SPLIT TAPE CORES	S.35 - S.43
7. RINGBANDKERNE/ TOROIDAL TAPE CORES RINGBANDKERNE/ TOROIDAL TAPE CORES RINGSCHNITTKERNE/ ROUND SPLIT CORES SONDERFORMEN (RINGBANDKERNE)/ SPECIAL SHAPES (TOROIDAL TAPE) WERKSTOFFE UND MAGNETQUALITÄTEN/ MATERIAL CLASS AND MAGNETIC QUALITIES	S.45 - S.51



KERNBLECHE

CORE LAMINATIONS

EI - KERNBLECHE/ EI - CORE LAMINATIONS

WEI - KERNBLECHE/ WEI - CORE LAMINATIONS

EE - KLEINKERNBLECHE/ EE - MINIATURE CORE LAMINATIONS

EK - KERNBLECHPAKETE / EK - CORE LAMINATION STACKS

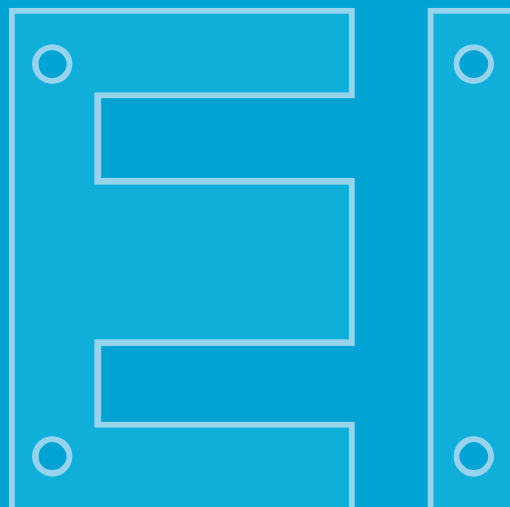

KERNBLECHE/ CORE LAMINATIONS

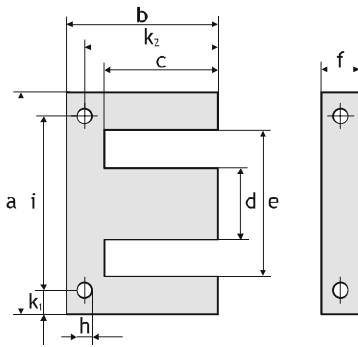

Bestell-Nr. Order-No.	Typ Type	IEC	a	b	c	d	e	f	h	i	k ₁	k ₂
11.005	EI 30	YEI 1 - 10	30,0	20,0	15,0	10,0	20,0	5,0	0,0	0,0	0,00	0,00
11.010	EI 38	YEI 1 - 13	38,4	25,6	19,2	12,8	25,6	6,4	0,0	0,0	0,00	0,00
11.020	EI 42	YEI 1 - 14	42,0	28,0	21,0	14,0	28,0	7,0	3,5	35,0	3,50	24,50
11.030	EI 48	YEI 1 - 16	48,0	32,0	24,0	16,0	32,0	8,0	3,5	40,0	4,00	28,00
11.040	EI 54	YEI 1 - 18	54,0	36,0	27,0	18,0	36,0	9,0	3,5	45,0	4,50	31,50
11.050	EI 60	YEI 1 - 20	60,0	40,0	30,0	20,0	40,0	10,0	3,5	50,0	5,00	35,00
11.060	EI 66	YEI 1 - 22	66,0	44,0	33,0	22,0	44,0	11,0	4,5	55,0	5,50	38,50
11.085	EI 75	YEI 1 - 25	75,0	50,0	37,5	25,0	50,0	12,5	4,5	62,5	6,25	43,75
11.095	EI 78		78,0	52,0	39,0	26,0	52,0	13,0	4,5	65,0	6,50	45,50
11.110	EI 84	YEI 1 - 28	84,0	56,0	42,0	28,0	56,0	14,0	4,5	70,0	7,00	49,00
11.120	EI 90		90,0	60,0	45,0	30,0	60,0	15,0	4,5	75,0	7,50	52,50
11.130	EI 96	YEI 1 - 32	96,0	64,0	48,0	32,0	64,0	16,0	5,5	80,0	8,00	56,00
11.140	EI 105		105,0	70,0	52,5	35,0	70,0	17,5	5,5	87,5	8,75	61,25
11.150	EI 108	YEI 1 - 36	108,0	72,0	54,0	36,0	72,0	18,0	5,5	90,0	9,00	63,00
11.160	EI 120	YEI 1 - 40	120,0	80,0	60,0	40,0	80,0	20,0	7,0	100,0	10,00	70,00
11.170	EI 126		126,0	84,0	63,0	42,0	84,0	21,0	7,0	105,0	10,50	73,50
11.180	EI 135		135,0	90,0	67,5	45,0	90,0	22,5	7,5	112,5	11,25	78,75
11.190	EI 150 N	YEI 1 - 50	150,0	100,0	75,0	50,0	100,0	25,0	8,0	125,0	12,50	87,50
11.200	EI 174	YEI 1 - 58	174,0	116,0	87,0	58,0	116,0	29,0	10,5	145,0	14,50	101,50
11.202	EI 180		180,0	120,0	90,0	60,0	120,0	30,0	10,0	150,0	15,00	105,00
11.210	EI 192	YEI 1 - 64	192,0	128,0	96,0	64,0	128,0	32,0	11,0	160,0	16,00	112,00
11.213	EI 240	YEI 1 - 80	240,0	160,0	120,0	80,0	160,0	40,0	11,5	200,0	20,00	140,00

Details und weitere Informationen können sie auf unserer Internetseite finden.
 Details and further information you will find on our web-site
<http://www.waasner.de>

EI - KERNBLECHE/ EI - CORE LAMINATIONS mit verlängertem Schenkel/ with extended limb

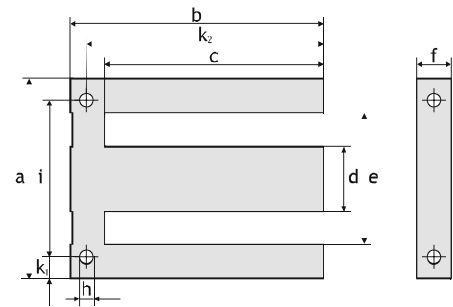

Bestell-Nr. Order-No.	Typ Type	a	b	c	d	e	f	h	i	k ₁	k ₂
13.015	EI 54/72	54,0	63,0	54,0	18,0	36,00	9,0	3,5	45,00	4,50	58,50
13.020	EI 60/80	60,0	70,0	60,0	20,0	40,00	10,0	3,5	50,00	5,00	65,00
13.025	EI 66/88	66,0	77,0	66,0	22,0	44,00	11,0	4,5	55,00	5,50	71,50
13.035	EI 78/104	78,0	91,0	78,0	26,0	52,00	13,0	4,5	65,00	6,50	84,50
13.040	EI 84/112	84,0	98,0	84,0	28,0	56,00	14,0	4,5	70,00	7,00	91,00
13.050	EI 96/128	96,0	112,0	96,0	32,0	64,00	16,0	5,5	80,00	8,00	104,00
13.055	EI 105/140	105,0	122,5	105,0	35,0	70,00	17,50	5,5	87,50	8,75	113,75
13.060	EI 120/160	120,0	140,0	120,0	40,0	80,00	20,0	7,0	100,00	10,00	130,00
13.075	EI 150/200	150,0	175,0	150,0	50,0	100,00	25,0	8,0	125,00	12,50	162,50

EI - KERNBLECHE/ EI - CORE LAMINATIONS

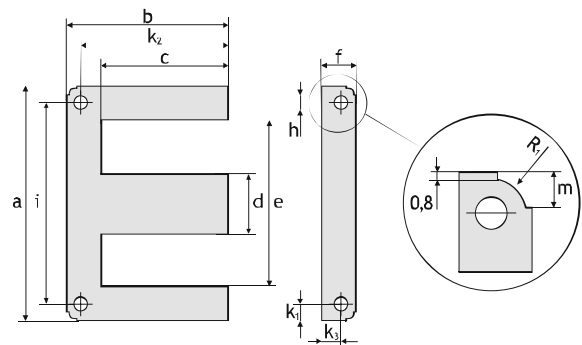

Bestell-Nr. Order-No.	Typ Type	a	b	c	d	e	f	h	i	k ₁	k ₂	k ₃	m	r ₁
12.016	EI 106	106	70,5	56	29	77	14,5	5,5	94,0	6,0	64,5	8,5	4,0	3,20
12.021	EI 130	130	87,5	70	35	95	17,5	6,8	115,0	7,5	80,0	10,0	6,0	5,75
12.031	EI 150	150	100,0	80	40	110	20,0	7,8	135,0	7,5	92,5	12,5	6,0	5,20
12.036	EI 170	170	117,5	95	45	125	22,5	8,0	150,0	10,0	107,5	12,5	8,0	7,20
12.041	EI 195	195	152,5	125	55	140	27,5	11,0	170,0	12,5	140,0	15,0	10,0	9,20
12.048	EI 231	231	176,5	144	65	166	32,5	13,0	201,0	15,0	161,5	17,5	10,0	9,20

EI-KERNBLECHE / CORE LAMINATIONS mit Luftspalt/ with air-gap

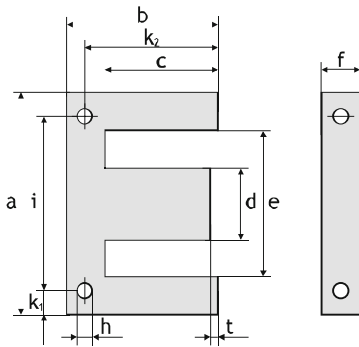

Bestell-Nr. Order-No.	mögliche Dicke pos. Thickness	Typ	a	b	c	d	e	f	h	i	(k ₁)	k ₂	t
11.001	0,35/0,50	EI 38	38,4	25,6	19,2	12,8	25,6	6,4	---	---	---	---	0,50
11.423	0,35	EI 38	38,4	25,6	19,2	12,8	25,6	6,4	---	---	---	---	0,60
11.419	0,50	EI 38	38,4	25,6	19,2	12,8	25,6	6,4	---	---	---	---	1,80
11.031	0,35	EI 48	48,0	32,0	24,0	16,0	32,0	8,0	3,5	40,0	4,00	28,00	0,37
11.329	0,35	EI 48	48,0	32,0	24,0	16,0	32,0	8,0	3,5	40,0	4,00	28,00	0,60
11.416	0,35/0,50	EI 48	48,0	32,0	24,0	16,0	32,0	8,0	---	---	---	---	3,00
11.357	0,35/0,50	EI 66	66,0	44,0	33,0	22,0	44,0	11,0	4,5	55,0	5,50	38,50	1,00
11.356	0,50	EI 66	66,0	44,0	33,0	22,0	44,0	11,0	4,5	55,0	5,50	38,50	1,20
11.376	0,35	EI 78	78,0	52,0	39,0	26,0	52,0	13,0	4,5	65,0	6,50	45,50	0,70
11.093	0,35/0,50	EI 78	78,0	52,0	39,0	26,0	52,0	13,0	4,5	65,0	6,50	45,50	1,00
11.373	0,35/0,50	EI 78	78,0	52,0	39,0	26,0	52,0	13,0	4,5	65,0	6,50	45,50	1,40
11.147	0,50	EI 84	84,0	56,0	42,0	28,0	56,0	14,0	4,5	70,0	7,00	49,00	0,85
11.375	0,50	EI 90	90,0	60,0	45,0	30,0	60,0	15,0	4,5	75,0	7,50	52,50	2,00
11.123	0,50	EI 90	90,0	60,0	45,0	30,0	60,0	15,0	4,5	75,0	7,50	52,50	4,00
11.136	0,35	EI 96	96,0	64,0	48,0	32,0	64,0	16,0	5,5	80,0	8,00	56,00	0,75
11.137	0,35/0,50	EI 96	96,0	64,0	48,0	32,0	64,0	16,0	5,5	80,0	8,00	56,00	1,95
11.421	0,50	EI 96	96,0	64,0	48,0	32,0	64,0	16,0	5,5	80,0	8,00	56,00	3,50
11.164	0,35	EI 120	120,0	80,0	60,0	40,0	80,0	20,0	7,0	100,0	10,00	70,00	2,10
11.168	0,50	EI 120	120,0	80,0	60,0	40,0	80,0	20,0	7,0	100,0	10,00	70,00	3,00
11.171	0,50	EI 120	120,0	80,0	60,0	40,0	80,0	20,0	7,0	100,0	10,00	70,00	4,00

„ Stand Februar 2017 - Änderungen auf Anfrage „

„ date of issue february 2017 - changes on request „

WEI - KERBLECHE

Die patentierte neue Schnittform WEI wurde speziell für den Transformatorbau zur Serienfertigung von geschweißten Transformatoren entwickelt. Dieser Schnitt, bereits millionenfach bewährt, zeichnet sich u.a. durch folgende gravierende Vorteile gegenüber dem herkömmlichen EI-Blech aus:

- Das Brummen eines verschweißten WEI - Transformatorenkernes ist nicht mehr wahrnehmbar, auch bei hoher Induktion.
- Das weitverbreitete Kleben der Mittelzunge bei geschweißten Transformatoren ist durch den Einsatz von WEI - Kernblechen nicht mehr notwendig.
- Hervorragende elektrische Werte, kleinere Leerlaufströme, kleinere Verlustleistung bedingt durch Entfall des Luftspaltes zwischen E + I - Teil.

Bei der Verarbeitung für den geschweißten Transformator ist zu beachten, daß das I-Blech mit der Kennung (Kennnut bzw. Kennnoppen) zu den E-Schenkel angelegt wird.

Für die Weiterverarbeitung mit der Schachtelmaschine ist dieser neue WEI - Schnitt gleichfalls geeignet.

Das I-Blech mit der Kennung wird dabei gegenüber dem geschweißtem Transformator um 180° gedreht, dadurch kommt die Kennung auf der Transformatoraußenseite zum Liegen.

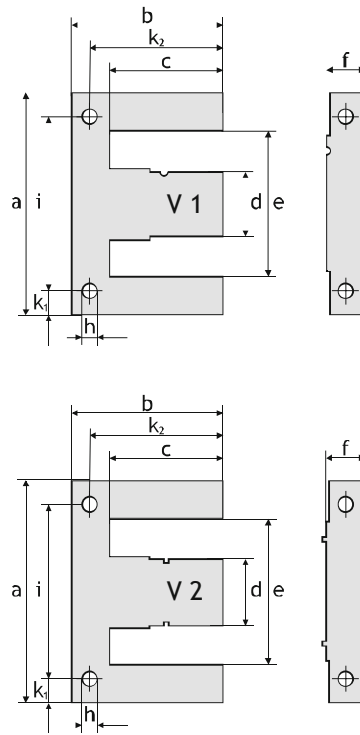

WEI - CORE LAMINATIONS

The patented new lamination type WEI was developed specially for transformer producers for the mass production of welded transformers. This type, which has already proved its worth millions of times, is characterized among other things by the following considerable advantages compared with conventional EI-laminations:

- The humming of a welded WEI transformer core can no longer be heard, even at high induction.
- Thanks to the use of WEI core laminations, the widespread bonding of the central tab is no longer necessary for welded transformers.
- Outstanding electrical values, lower no-load current, lower power loss due to the absence of an air gap between E + I parts.

When processing the welded transformer, please note that the I lamination is positioned with the marker (marked groove or marked tongue) facing the E limb.

This new WEI type is also suitable for further processing with laminating machine. The I lamination with the marker is rotated by 180° in relation to the welded transformer, which means that the marker is then located on the outside of the transformer.

Bestell-Nr. Order-No.	V	Type Typ	a	b	c	d	e	f	h	i	k ₁	k ₂
11.303	2	WEI 38	38,40	25,6	19,2	12,80	25,60	6,40	0,0	0,00	0,00	0,00
11.304	2	WEI 38	38,40	25,6	19,2	12,80	25,60	6,40	2,6	32,00	3,20	22,40
11.323	2	WEI 42	42,00	28,0	21,0	14,00	28,00	7,00	0,0	0,00	0,00	0,00
11.324	2	WEI 42	42,00	28,0	21,0	14,00	28,00	7,00	3,5	35,00	3,50	24,50
11.327	2	WEI 48	48,00	32,0	24,0	16,00	32,00	8,00	0,0	0,00	0,00	0,00
11.328	2	WEI 48	48,00	32,0	24,0	16,00	32,00	8,00	3,5	40,00	4,00	28,00
11.338	2	WEI 54	54,00	36,0	27,0	18,00	36,00	9,00	0,0	0,00	0,00	0,00
11.336	2	WEI 54	54,00	36,0	27,0	18,00	36,00	9,00	3,5	45,00	4,50	31,50
11.354	2	WEI 60	60,00	40,0	30,0	20,00	40,00	10,00	0,0	0,00	0,00	0,00
11.355	2	WEI 60	60,00	40,0	30,0	20,00	40,00	10,00	3,5	50,00	5,00	35,00
11.358	2	WEI 66	66,00	44,0	33,0	22,00	44,00	11,00	0,0	0,00	0,00	0,00
11.359	2	WEI 66	66,00	44,0	33,0	22,00	44,00	11,00	4,5	55,00	5,50	38,50
11.360	1	WEI 78	78,00	52,0	39,0	26,00	52,00	13,00	0,0	0,00	0,00	0,00
11.361	1	WEI 78	78,00	52,0	39,0	26,00	52,00	13,00	4,5	65,00	6,50	45,50
11.365	1	WEI 84	84,00	56,0	42,0	28,00	56,00	14,00	0,0	0,00	0,00	0,00
11.366	1	WEI 84	84,00	56,0	42,0	28,00	56,00	14,00	4,5	70,00	7,00	49,00
11.367	1	WEI 96	96,00	64,0	48,0	32,00	64,00	16,00	0,0	0,00	0,00	0,00
11.368	1	WEI 96	96,00	64,0	48,0	32,00	64,00	16,00	5,5	80,00	8,00	56,00
11.369	1	WEI 120	120,00	80,0	60,0	40,00	80,00	20,00	0,0	0,00	0,00	0,00
11.370	1	WEI 120	120,00	80,0	60,0	40,00	80,00	20,00	7,0	100,00	10,00	70,00

WEI - KERNBLECHE/ WEI - CORE LAMINATIONS mit verlängertem Schenkel/ with extended limb

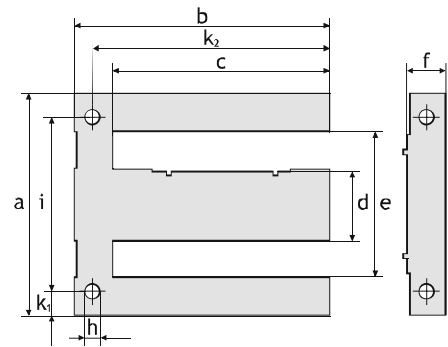

Bestell-Nr. Order-No.	Typ Type	a	b	c	d	e	f	h	i	k ₁	k ₂
13.327	WEI 66/88	66	77	66	22	44	11	4,5	55	5,5	71,5
13.044	WEI 84/112	84	98	84	28	56	14	4,5	70	7,0	91,0

Details und weitere Informationen können sie auf unserer Internetseite finden.
Details and further information you will find on our web-site
<http://www.waasner.de>

EE - KLEINKERNBLECHE / EE - MINIATURE CORE LAMINATIONS

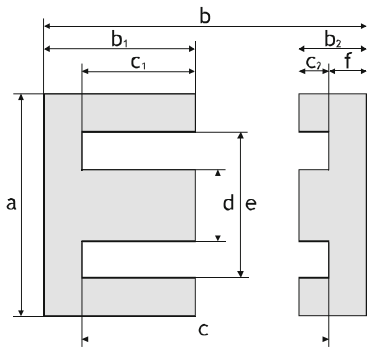

Bestell-Nr. Order-No.	Typ Type	IEC	a	b	b ₁	b ₂	c	c ₁	c ₂	d	e	f
10.115	EE 16	YEE 2 - 5	16,00	16,00	11,0	5,00	11,20	8,60	2,60	4,80	11,20	2,40
10.100	EE 20	YEE 2 - 6	20,00	20,00	14,0	6,00	14,00	11,00	3,00	6,00	14,00	3,00
10.105	EE 25	YEE 2 - 8	25,00	25,00	17,0	8,00	17,40	13,20	4,20	7,60	17,40	3,80
10.125	EE 32	YEE 2 - 10	32,00	32,00	22,0	10,00	22,40	17,20	5,20	9,60	22,40	4,80
10.130	EE 40	YEE 2 - 12	40,00	40,00	28,0	12,00	28,00	22,00	6,00	12,00	28,00	6,00

EK - KERNBLECHPAKETE / EK - CORE LAMINATION STACKS

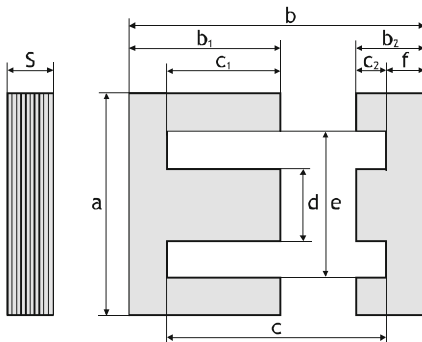

Bestell-Nr. Order-No.	Typ Type	IEC	a	b	b ₁	b ₂	c	c ₁	c ₂	d	e	f	S
10.040	EK 16	YEE 2 - 5 dK	16,00	16,00	11,0	5,00	11,20	8,60	2,60	4,80	11,20	2,40	4,8
10.053	EK 20	YEE 2 - 6 dK	20,00	20,00	14,0	6,00	14,00	11,00	3,00	6,00	14,00	3,00	6,0
10.045	EK 20 L	YEE 2 - 6 dKL	20,00	28,00	14,0	14,00	22,00	11,00	11,00	6,00	14,00	3,00	6,0
10.055	EK 25	YEE 2 - 8 dK	25,00	25,00	17,0	8,00	17,40	13,20	4,20	7,60	17,40	3,80	7,6
10.050	EK 25 L	YEE 2 - 8 dKL	25,00	34,00	17,0	17,00	26,40	13,20	13,20	7,60	17,40	3,80	7,6
10.060	EK 32	YEE 2 - 10 dK	32,00	32,00	22,0	10,00	22,40	17,20	5,20	9,60	22,40	4,80	9,6
10.065	EK 32 L	YEE 2 - 10 dKL	32,00	44,00	22,0	22,00	34,40	17,20	17,20	9,60	22,40	4,80	9,6
10.070	EK 40	YEE 2 - 12 dK	40,00	40,00	28,0	12,00	28,00	22,00	6,00	12,00	28,00	6,00	12,0
10.075	EK 40 L	YEE 2 - 12 dKL	40,00	56,00	28,0	28,00	44,00	22,00	22,00	12,00	28,00	6,00	12,0

IHRE NOTIZEN/ YOUR NOTES

Details und weitere Informationen können sie auf unserer Internetseite finden.
Details and further information you will find on our web-site

<http://www.waasner.de>





STECKKERNBLECHE

READY-CORE LAMINATIONS

EI../2R

EE../2R

M../2R

WUI../2R

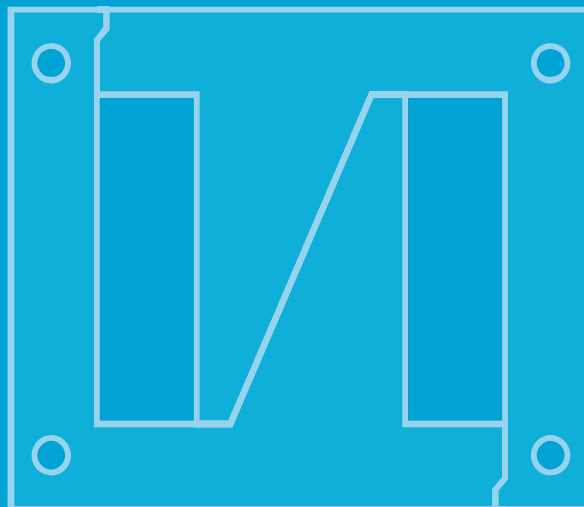

STECKKERNBLECHE / READY-CORE LAMINATIONS EI../2MR

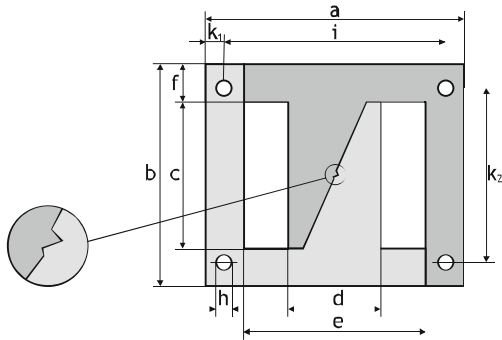

Bestell-Nr. Order-No.	Typ Type		a	b	c	d	e	f	h	i	k ₁	k ₂
11.003	EI 30 / 2MR		30,0	25,0	15,0	10,0	20,0	5,0	0,0	0,0	0,0	0,0
11.312	EI 38 / 2MR		38,4	32,0	19,2	12,8	25,6	6,4	0,0	0,0	0,0	0,0
11.313	EI 38 / 2MR	*	38,4	32,0	19,2	12,8	25,6	6,4	2,8	32,0	3,2	25,6
11.317	EI 42 / 2MR		42,0	35,0	21,0	14,0	28,0	7,0	0,0	0,0		0,0
11.322	EI 42 / 2MR	*	42,0	35,0	21,0	14,0	28,0	7,0	3,5	35,0	3,5	28,0
11.033	EI 48 / 2MR		48,0	40,0	24,0	16,0	32,0	8,0	0,0	0,0	0,0	0,0
11.034	EI 48 / 2MR	*	48,0	40,0	24,0	16,0	32,0	8,0	3,5	40,0	4,0	32,0
11.337	EI 54 / 2MR		54,0	45,0	27,0	18,0	36,0	9,0	0,0	0,0	0,0	0,0
11.342	EI 54 / 2MR	*	54,0	45,0	27,0	18,0	36,0	9,0	3,5	45,0	4,5	36,0

* mit Loch / with hole

KLEINSTECKKERNBLECHE/ MINIATURE READY-CORE LAMINATIONS EE../2R

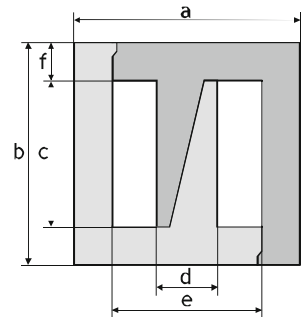

Bestell-Nr. Order-No.	Typ Type	a	b	c	d	e	f
10.102	EE 20/ 2IR	20,00	20,00	14,00	6,00	14,00	3,00

STECKKERNBLECHE/ READY-CORE LAMINATIONS M../2SpR

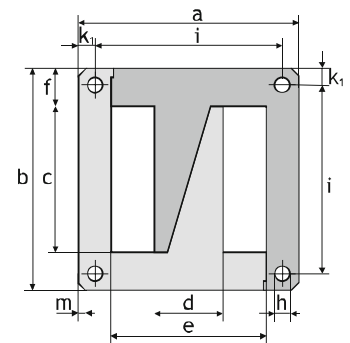

Bestell-Nr. Order-No.		Typ Type	a	b	c	d	e	f	h	i	k ₁	m
21.024	*	M 42/ 2SpR	42,00	42,00	28,50	12,00	30,00	6,75	3,5	0,00	21,000	2,0
21.054	**	M 55/ 2SpR	55,00	55,00	36,00	17,00	38,00	9,50	3,5	47,00	4,000	2,0
21.069	**	M 65/ 2SpR	65,00	65,00	42,50	20,00	45,00	11,25	4,5	56,00	4,500	2,0
21.094	**	M 74/ 2SpR	74,00	74,00	48,50	23,00	51,00	12,75	4,5	64,00	5,000	2,0
21.119	**	M 85/ 2SpR	85,00	85,00	53,00	29,00	56,00	16,00	4,5	75,00	5,000	3,0
21.144	**	M 102/ 2SpR	102,00	102,00	64,50	34,00	68,00	18,75	5,5	91,00	5,500	3,0

*mit 2 Loch/with 2 holes

**mit 4 Loch/with 4 holes

STECKKERNBLECHE / READY-CORE LAMINATIONS WUI../2RS

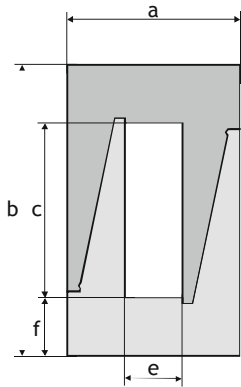

Bestell-Nr. Order-No.	Typ Type	a	b	c	e	f
31.002	WUI 30/ 2RS	30,00	50,00	30,00	10,00	10,00
31.027	WUI 39/ 2RS	39,00	65,00	39,00	13,00	13,00
31.042	WUI 48/ 2RS	48,00	80,00	48,00	16,00	16,00



GEBRÜDER WAASNER
 Elektrotechnische Fabrik GmbH
 Bamberger Straße 85 · D-91301 Forchheim

Tel.: +49 (0) 91 91 - 6 12-0 · Fax: +49 (0) 91 91 - 6 79 91
 Mail: info@waasner.de

IHRE NOTIZEN/ YOUR NOTES





KERNBLECHE

CORE LAMINATIONS

UI - KERNBLECHE/ UI - CORE LAMINATIONS

3UI - DREHSTROMBLECHE/ 3UI - PHASE LAMINATIONS



UI - KERNBLECHE/ UI - CORE LAMINATIONS

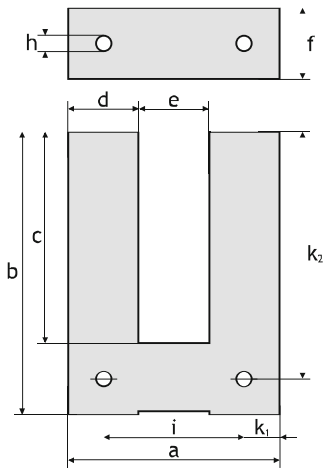

Bestell-Nr. Order-No.	Typ Type	IEC	a	b	c	d	e	f	h	i	k ₁	k ₂
31.010	UI 30	YUI 1 - 10	30,00	40,00	30,00	10,00	10,00	10,00	3,5	20,00	5,000	35,000
31.020	UI 39	YUI 1 - 13	39,00	52,00	39,00	13,00	13,00	13,00	3,5	26,00	6,500	45,500
31.030	UI 48	YUI 1 - 16	48,00	64,00	48,00	16,00	16,00	16,00	4,5	32,00	8,000	56,000
31.045	UI 60	YUI 1 - 20	60,00	80,00	60,00	20,00	20,00	20,00	4,5	40,00	10,000	70,000
31.055	UI 75	YUI 1 - 25	75,00	100,00	75,00	25,00	25,00	25,00	5,5	50,00	12,500	87,500
31.065	UI 90	YUI 1 - 30	90,00	120,00	90,00	30,00	30,00	30,00	7,8	60,00	15,000	105,000
31.115	UI 102	YUI 1 - 34	102,00	136,00	102,00	34,00	34,00	34,00	7,8	68,00	17,000	119,000
31.070	UI 105		105,00	140,00	105,00	35,00	35,00	35,00	8,0	70,00	17,500	122,500
31.120	UI 114	YUI 1 - 38	114,00	152,00	114,00	38,00	38,00	38,00	11,0	76,00	19,000	133,000
31.075	UI 120		120,00	160,00	120,00	40,00	40,00	40,00	11,0	80,00	20,000	140,000
31.090	UI 132	YUI 1 - 44	132,00	176,00	132,00	44,00	44,00	44,00	11,0	88,00	22,000	154,000
31.095	UI 150	YUI 1 - 50	150,00	200,00	150,00	50,00	50,00	50,00	11,0	100,00	25,000	175,000
31.085	UI 168	YUI 1 - 56	168,00	224,00	168,00	56,00	56,00	56,00	11,0	112,00	28,000	196,000
31.105	UI 180	YUI 1 - 60	180,00	240,00	180,00	60,00	60,00	60,00	11,0	120,00	30,000	210,000
31.100	UI 210	YUI 1 - 70	210,00	280,00	210,00	70,00	70,00	70,00	15,0	140,00	35,000	245,000
31.101	UI 240	YUI 1 - 80	240,00	320,00	240,00	80,00	80,00	80,00	15,0	160,00	40,000	280,000



GEBRÜDER WAASNER
 Elektrotechnische Fabrik GmbH
 Bamberger Straße 85 · D-91301 Forchheim

Tel.: +49 (0) 91 91 - 6 12-0 · Fax: +49 (0) 91 91 - 6 79 91
 Mail: info@wasner.de

3UI - DREHSTROMBLECHE / 3UI - PHASE LAMINATIONS

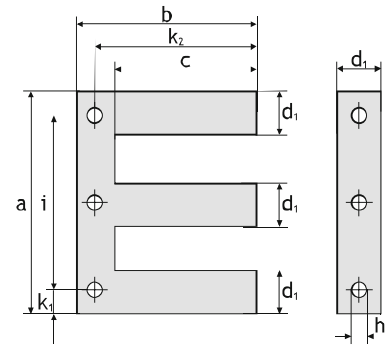

Bestell-Nr. Order-No.		Typ Type	IEC	a ³⁾	b	c ⁴⁾	d ₁	h ¹⁾	i ¹⁰⁾	k ₁	k ₂
14.490	*	3 UI 30 / EI 50/50	YUI 2 - 10	50,00	40,00	30,00	10,0	3,5	40,00	5,00	35,00
14.495	*	3 UI 39 / EI 65/65	YUI 2 - 13	65,00	52,00	39,00	13,0	3,5	52,00	6,50	45,50
14.500	*	3 UI 48 / EI 80/80	YUI 2 - 16	80,00	64,00	48,00	16,0	4,5	64,00	8,00	56,00
14.505	*	3 UI 60 / EI 100/100	YUI 2 - 20	100,00	80,00	60,00	20,0	4,5	80,00	10,00	70,00
14.510		3 UI 75 / EI 125/125	YUI 2 - 25	125,00	100,00	75,00	25,0	5,5	100,00	12,50	87,50
14.515		3 UI 90 / EI 150/150	YUI 2 - 30	150,00	120,00	90,00	30,0	8,5	120,00	15,00	105,00
14.550		3 UI 102 / EI 170/170	YUI 2 - 34	170,00	136,00	102,00	34,0	8,5	136,00	17,00	119,00
14.520		3 UI 105 / EI 175/175		175,00	140,00	105,00	35,0	8,5	140,00	17,50	122,50
14.555		3 UI 114 / EI 190/190	YUI 2 - 38	190,00	152,00	114,00	38,0	11,0	152,00	19,00	133,00
14.525		3 UI 120 / EI 200/200		200,00	160,00	120,00	40,0	11,0	160,00	20,00	140,00
14.560		3 UI 132 / EI 220/220	YUI 2 - 44	220,00	176,00	132,00	44,0	11,0	176,00	22,00	154,00
14.530		3 UI 150 / EI 250/250	YUI 2 - 50	250,00	200,00	150,00	50,0	11,0	200,00	25,00	175,00
14.535		3 UI 168 / EI 280/280	YUI 2 - 56	280,00	224,00	168,00	56,0	11,0	224,00	28,00	196,00
14.540		3 UI 180 / EI 300/300	YUI 2 - 60	300,00	240,00	180,00	60,0	11,0	240,00	30,00	210,00
14.545		3 UI 210 / EI 350/350	YUI 2 - 70	350,00	280,00	210,00	70,0	15,0	280,00	35,00	245,00
14.546		3 UI 240 / EI 400/400	YUI 2 - 80	400,00	320,00	240,00	80,0	15,0	320,00	40,00	280,00

* = 4 Loch / * = 4 holes

Details und weitere Informationen können sie auf unserer Internetseite finden.
 Details and further information you will find on our web-site

<http://www.waasner.de>





STREIFENBLECHE STRIP LAMINATIONS

STREIFENBLECHE / STRIP LAMINATIONS



STREIFENBLECHE STRIP LAMINATIONS

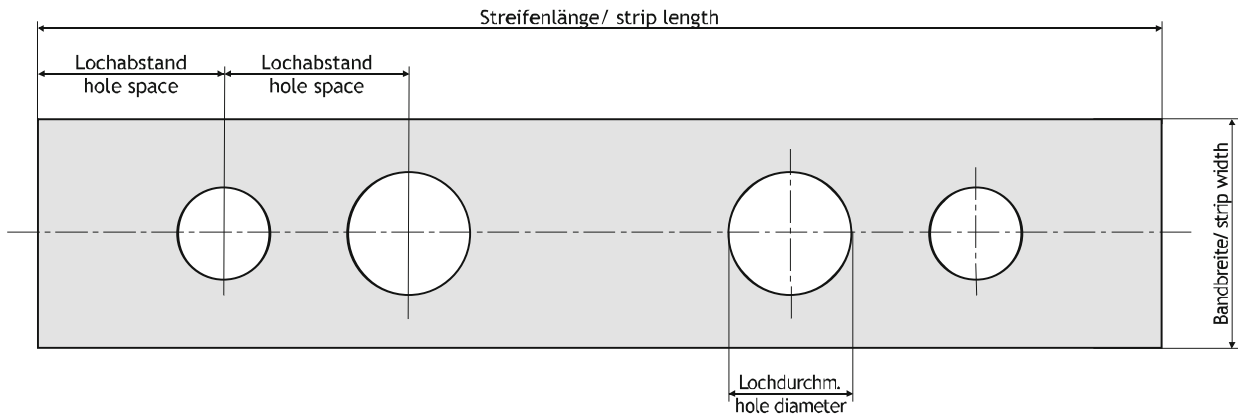

Mit den modernsten Einrichtungen ist WAASNER in der Lage Streifenbleche aus allen Materialqualitäten in variablen Längen, Breiten, Lochabständen und Lochdurchmesser kurzfristig zu fertigen.

Using the latest equipment, WAASNER is in a position to produce strip laminations in all material qualities in variable lengths, widths, hole spacings and hole diameter, all at short notice.

Details entnehmen Sie bitte aus der nachstehenden Checkliste:

For details please refer to the following checklist:

Bandbreite:	min. 10 mm	max. 400 mm
Streifenlänge:	min. 20 mm	max. 3000 mm
Lochdurchmesser	min. 4,5 mm	max. 28 mm
Anzahl der verschiedenen Lochdurchmesser:	max. 3	
Materialstärke	0,27 / 0,30 / 0,35 / 0,50 mm	

Strip width:	min. 10 mm	max. 400 mm
Strip length:	min. 20 mm	max. 3000 mm
Hole diameter:	min. 4.5 mm	max. 28 mm
Number of different diameters:	max. 3	
Material thickness	0.27 / 0.30 / 0.35 / 0.50 mm	

Größere Abmessungen und/oder angeschrägte Streifen auf Anfrage.

Larger dimensions and/or beveled strips on request.



GEBRÜDER WAASNER
Elektrotechnische Fabrik GmbH
Bamberger Straße 85 · D-91301 Forchheim

Tel.: +49 (0) 91 91 - 6 12-0 · Fax: +49 (0) 91 91 - 6 79 91
Mail: info@waasner.de

IHRE NOTIZEN/ YOUR NOTES

Details und weitere Informationen können sie auf unserer Internetseite finden.
Details and further information you will find on our web-site

<http://www.waasner.de>





MAGNETISCHE UND TECHNOLOGISCHE EIGENSCHAFTEN

MAGNETIC AND TECHNOLOGICAL PROPERTIES

MAGNETISCHE UND TECHN.EIGENSCHAFTEN/ MAGNETIC AND TECHN. PROPERTIES

DIN EN 10106
DIN EN 10107

MAGNETISCHE UND TECHNOLOGISCHE EIGENSCHAFTEN

Tabelle 2: aus DIN EN 10106 kaltgewalztes Elektroblech und -band im schlußgeglühten Zustand

MAGNETIC AND TECHNOLOGICAL PROPERTIES

Table 2: from DIN EN 10106 Cold-rolled magnetic steel lamination and strip in final heat treated state

Bezeichnung nach			Nenn- dicke	Ummagne- tierungs- verluste bei 50 HZ W/kg bei	Magnetische Polarisation T, min. im Wechselfeld bei einer magnetischen Feldstärke in A/m von			Anisotro- pie des Ummagne- tierungs- verlustes %	Stap- el- fak- tor	Biege- zahl	Verein- barte Werte der Dichte kg/dm ³
Designation acc. to					No- minal thick- ness	Magnetic re- versal losses at 50 HZ W/kg at	Magnetic polarisation T, min. in alternating field at a magnetic field strength in A/m of				
EN 10106	Vorzugs- reihe Preferred Series	Nr. / No.	mm	1,5T max.			2.500	5.000	10.000	max.	min.
M 235-35A		1.0890	0,35	2,35	1,49	1,60	1,70	±17	0,95	2	7,60
M 250-35A	X	1.0800		2,50	1,49	1,60	1,70	±17		2	7,60
M 270-35A		1.0801		2,70	1,49	1,60	1,70	±17		2	7,65
M 300-35A		1.0803		3,00	1,49	1,60	1,70	±17		3	7,65
M 330-35A	X	1.0804		3,30	1,49	1,60	1,70	±17		3	7,65
M 250-50A		1.0891	0,50	2,50	1,49	1,60	1,70	±17	0,97	2	7,60
M 270-50A		1.0806		2,70	1,49	1,60	1,70	±17		2	7,60
M 290-50A		1.0807		2,90	1,49	1,60	1,70	±17		2	7,60
M 310-50A		1.0808		3,10	1,49	1,60	1,70	±14		3	7,65
M 330-50A	X	1.0809		3,30	1,49	1,60	1,70	±14		3	7,65
M 350-50A		1.0810		3,50	1,50	1,60	1,70	±12		5	7,65
M 400-50A	X	1.0811		4,00	1,53	1,63	1,73	±12		5	7,70
M 470-50A		1.0812		4,70	1,54	1,64	1,74	±10		10	7,70
M 530-50A	X	1.0813		5,30	1,56	1,65	1,75	±10		10	7,70
M 600-50A		1.0814		6,00	1,57	1,66	1,76	±10		10	7,75
M 700-50A	X	1.0815		7,00	1,60	1,69	1,77	±10		10	7,80
M 800-50A	X	1.0816	8,00	1,60	1,70	1,78	±10	10	7,80		
M 310-65A		1.0892	0,65	3,10	1,49	1,60	1,70	±15	0,97	2	7,60
M 330-65A		1.0819		3,30	1,49	1,60	1,70	±15		2	7,60
M 350-65A		1.0820		3,50	1,49	1,60	1,70	±14		2	7,60
M 400-65A		1.0821		4,00	1,52	1,62	1,72	±14		2	7,65
M 470-65A		1.0823		4,70	1,53	1,63	1,73	±12		5	7,65
M 530-65A		1.0824		5,30	1,54	1,64	1,74	±12		5	7,70
M 600-65A		1.0825		6,00	1,56	1,66	1,76	±10		10	7,75
M 700-65A		1.0826		7,00	1,57	1,67	1,76	±10		10	7,75
M 800-65A	X	1.0827		8,00	1,60	1,70	1,78	±10		10	7,80

Tabelle 2: aus DIN EN 10107 kornorientiertes Elektroblech und -band im schlußgeglühten Zustand

Table 2: from DIN EN 10107 Grain-oriented magnetic steel lamination and strip in final heat treated state

Bezeichnung nach		Nenn- dicke	Ummagnetisierungs- verluste bei 50 HZ W/kg bei		Magnetische Polarisation T, min. im Wechselfeld bei einer magnetischen Feldstärke in A/m von	Stapel- faktor
Designation acc. to		Nominal thickness	Magnetic reversal losses at 50 HZ W/kg at		Magnetic polarisation T, min. in alternating field at a magnetic field strength in A/m of	Stacking factor
Vorzugsreihe Preferred Series	Nr. / No.					
EN 10107		mm	1,5T max.	1,7T max.	800	min.
M 127-23S (M 080-23N)		0,23	0,80	1,27	1,75	0,945
M 140-27S (M 089-27N)	X	0,27	0,89	1,40	1,75	0,950
M 150-30S (M 097-30N)	X	0,30	0,97	1,50	1,75	0,955
M 165-35S (M 111-35N)	X	0,35	1,11	1,65	1,75	0,960
M 105-30P	X	0,30	-	1,05	1,88	0,955

Die in vorstehenden Tabellen aufgeführten Werte gelten nicht für gestanzte Teile.

The values listed in the above tables do not apply for stamped parts.



GEBRÜDER WAASNER
 Elektrotechnische Fabrik GmbH
 Bamberger Straße 85 · D-91301 Forchheim

Tel.: +49 (0) 91 91 - 6 12-0 · Fax: +49 (0) 91 91 - 6 79 91
 Mail: info@waasner.de



SCHNITTBANDKERNE

SPLIT TAPE CORES

SM - REIHE/ SM - LINE

SE - REIHE/ SE - LINE

SU- REIHE/ SU - LINE

S3U - REIHE/ S3U - LINE

SG - REIHE/ SG - LINE

SONDERFORMEN/ SPECIAL SPLIT TAPE CORE DESIGNS

GARANTIE FÜR SCHNITTBANDKERNE/ GUARENTEES FOR SPLIT TAPE CORES





SCHNITTBANDKERNE SM/ SPLIT TAPE CORES SM

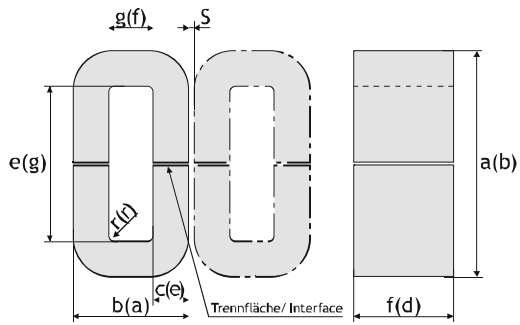

Angaben in (...) = IEC 60329 Bemaßung/ Descripton in (...) = IEC 60329 dimension

Abmessungen (mech. Daten) Dimensions (mechanical data)

Bestell-Nr. Order-No.	Typ DIN	Typ IEC	a	b	c	c	e	f	f	g	r	s	I _{Fe}	A _{FE}	m _{FE}	zugehörige Spulenkörper Matching bobbin	
			max	max.		zul. Abw. c Perm. dev.	min.		zul. Abw. f Perm. dev.	min.	max.					kg	Type u.Größe type and size
			mm	mm	mm	mm	mm	mm	mm	mm	mm	mm	cm	cm ²			
51.005	SM 30a ¹⁾	M 1.1	28,6	14,3	3,5	-0,5	21,0	7,0	-0,5	7,0	1,0	0,4	6,6	0,18	0,0091	M 30 a	
51.010	SM 30b ¹⁾	M 1.2	28,6	14,3	3,5	-0,5	21,0	11,0	-0,5	7,0	1,0	0,4	6,6	0,29	0,0147	M 30 b	
51.015	SM 42	M 2.1	43,6	21,8	6,0	-0,8	31,0	15,2	-0,7	9,5	1,5	0,4	9,8	0,72	0,0541	M 42	
51.020	SM 55	M 3.1	56,3	28,4	8,5	-0,8	38,5	20,8	-0,8	11,0	1,5	0,4	12,4	1,46	0,1380	M 55	
51.025	SM 65	M 4.1	65,6	33,2	9,9	-0,9	45,0	27,0	-0,8	13,0	1,5	0,6	14,6	2,24	0,2500	M 65	
51.030	SM 74	M 5.1	74,6	37,7	11,4	-0,9	51,0	32,5	-1,0	14,5	1,5	0,6	16,5	3,14	0,3960	M 74	
51.035	SM 85a	M 6.1	85,6	43,2	14,4	-1,0	56,0	32,5	-1,0	14,0	2,0	0,6	18,3	4,01	0,5610	M 85 a	
51.040	SM 85b	M 6.2	85,6	43,2	14,4	-1,0	56,0	45,5	-1,0	14,0	2,0	0,6	18,3	5,66	0,7920	M 85 b	
51.045	SM 102a	M 7.1	103,0	51,9	16,9	-1,0	68,0	35,5	-1,0	17,5	2,0	0,6	22,2	5,21	0,8850	M 102 a	
51.050	SM 102b	M 7.2	103,0	51,9	16,9	-1,0	68,0	52,5	-1,0	17,5	2,0	0,6	22,2	7,78	1,3200	M 102 b	

1) Nur in 0,1 mm Banddicke lieferbar.

1) Available in 0,1 mm Tape thickness only

Details und weitere Informationen können sie auf unserer Internetseite finden.
 Details and further information you will find on our web-site
<http://www.waasner.de>

SCHNITTBANDKERNE SE/ SPLIT TAPE CORES SE

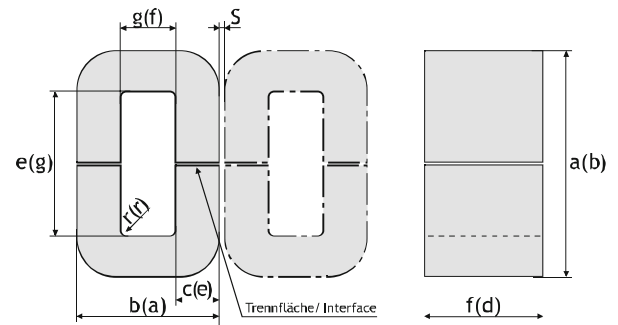

Angaben in (...) = IEC 60329 Bemaßung/ Descripton in (...) = IEC 60329 dimension

Abmessungen (mech. Daten) Dimensions (mechanical data)

Bestell-Nr. Order-No.	Typ DIN Type DIN	Typ IEC Type IEC	a	b	c	c	e	f	f	g	r	s	l_{Fe}	A_{FE}	m_{FE}	zugehörige Spulen- körper Mat- ching bobbin
			max	max.		zul. Abw. c Perm. dev.	min.		zul. Abw. f Perm. dev.	min.	max.		cm	cm ²	kg	Type u. Größe type and size
			mm	mm	mm	mm	mm	mm	mm	mm	mm	mm	cm	cm ²	kg	Type u. Größe type and size
50.105	(SE 60)	--	52,2	30,5	9,9	-0,8	32	20,5	-0,8	10,5	1,5	0,6	11,4	1,72	0,150	EI 60
50.110	(SE 66)	--	57,2	33,5	10,9	-0,8	35	22,5	-0,8	11,5	1,5	0,6	12,5	2,08	0,199	EI 66
50.115	(SE 78)	--	68,2	39,5	12,9	-0,8	42	27,0	-0,9	13,5	2,0	0,6	14,9	3,00	0,342	EI 78
50.120	(SE 84a)	--	73,4	42,6	13,9	-0,8	45	29,0	-1,0	14,5	2,0	0,6	16,0	3,48	0,426	EI 84a
50.125	(SE 84b)	--	73,4	42,6	13,9	-0,8	45	43,0	-1,0	14,5	2,0	0,6	16,0	5,23	0,640	EI 84b
50.130	(SE 92a)	--	77,6	46,2	11,4	-0,8	54	24,0	-1,0	23,0	2,0	0,6	18,7	2,32	0,332	EI 92a
50.135	(SE 92b)	--	77,6	46,2	11,4	-0,8	54	33,0	-1,0	23,0	2,0	0,6	18,7	3,22	0,461	EI 92b
50.140	(SE 106a)	--	88,6	53,2	14,4	-0,8	59	33,0	-1,0	24,0	2,0	0,6	20,9	4,13	0,660	EI 106a
50.145	(SE 106b)	--	88,6	53,2	14,4	-0,8	59	46,0	-1,0	24,0	2,0	0,6	20,9	5,81	0,929	EI 106b
50.005	SE 130a	R 1.1	108,8	65,3	17,4	-0,9	73	37,2	-1,2	30,0	2,0	0,6	25,9	5,64	1,117	EI 130a
50.010	SE 130b	R 1.2	108,8	65,3	17,4	-0,9	73	47,2	-1,2	30,0	2,0	0,6	25,9	7,21	1,429	EI 130b
50.015	SE 150a	R 2.1	123,8	75,2	19,8	-0,9	83	41,2	-1,2	35,0	2,0	0,6	29,7	7,18	1,631	EI 150a
50.020	SE 150b	R 2.2	123,8	75,2	19,8	-0,9	83	51,2	-1,2	35,0	2,0	0,6	29,7	8,98	2,040	EI 150b
50.025	SE 150c	R 2.3	123,8	75,2	19,8	-0,9	83	61,2	-1,2	35,0	2,0	0,6	29,7	10,80	2,454	EI 150c
50.030	SE 170a	R 3.1	145,8	85,0	22,1	-1,0	100	56,0	-1,5	40,0	3,0	0,7	34,7	10,90	2,920	EI 170a
50.035	SE 170b	R 3.2	145,8	85,0	22,1	-1,0	100	66,0	-1,5	40,0	3,0	0,7	34,7	12,90	3,424	EI 170b
50.040	SE 170c	R 3.3	145,8	85,0	22,1	-1,0	100	76,0	-1,5	40,0	3,0	0,7	34,7	14,90	3,955	EI 170c
50.045	SE 195a	R 4.1	186,8	98,2	27,3	-1,1	130	57,0	-1,5	42,5	3,0	1,0	42,9	13,80	4,529	EI 195a
50.050	SE 195b	R 4.2	186,8	98,2	27,3	-1,1	130	70,0	-1,5	42,5	3,0	1,0	42,9	17,00	5,579	EI 195b
50.055	SE 195c	R 4.3	186,8	98,2	27,3	-1,1	130	85,0	-1,5	42,5	3,0	1,0	42,9	20,80	6,826	EI 195c
50.060	SE 231a	R 5.1	216,0	116,1	32,1	-1,3	149	63,0	-1,5	50,5	3,0	1,2	49,9	18,00	6,871	EI 231a
50.065	SE 231b	R 5.2	216,0	116,1	32,1	-1,3	149	79,0	-1,5	50,5	3,0	1,2	49,9	22,70	8,665	EI 231b
50.070	SE 231c	R 5.3	216,0	116,1	32,1	-1,3	149	98,0	-1,5	50,5	3,0	1,2	49,9	28,20	10,765	EI 231c

SCHNITTBANDKERNE SU/ SPLIT TAPE CORES SU

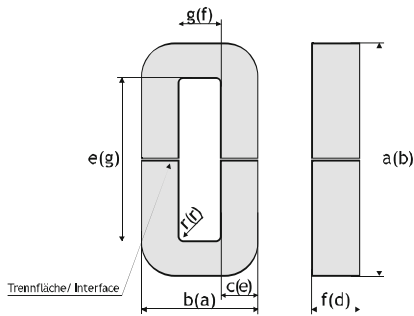

Angaben in (...) = IEC 60329 Bemaßung
 Descripton in (...) = IEC 60329 dimension

Abmessungen (mech. Daten)/ Dimensions (mechanical data)

Bestell-Nr. Order-No.	Typ DIN	Typ IEC	a	b	c	c	e	f	f	g	r	s	I_{Fe}	A_{FE}	m_{FE}	zugehörige Spulenkörper Matching bobbin
			max.	max		zul. Abw. c Perm. dev.	min.		zul. Abw. f Perm. dev.	min.	max.					Type u. Größe type and size
			mm	mm	mm	mm	mm	mm	mm	mm	mm	mm	cm	cm ²	kg	
52.025	SU 30a	U 1.1	52,7	30,0	9,9	-0,8	32,5	10,1	-0,6	10	1,5	0,2	11,4	0,82	0,0715	UI 30a
52.030	SU 30b	U 1.2	52,7	30,0	9,9	-0,8	32,5	16,1	-0,6	10	1,5	0,2	11,4	1,34	0,1170	UI 30b
52.035	SU 39a	U 2.1	67,9	39,1	12,9	-0,8	41,5	13,4	-0,9	13	1,5	0,3	14,8	1,44	0,1630	UI 39a
52.040	SU 39b	U 2.2	67,9	39,1	12,9	-0,8	41,5	20,4	-0,9	13	1,5	0,3	14,8	2,24	0,2540	UI 39b
52.045	SU 48a	U 3.1	82,9	48,0	15,8	-0,9	50,5	16,5	-1,0	16	1,5	0,3	18,1	2,19	0,3030	UI 48a
52.050	SU 48b	U 3.2	82,9	48,0	15,8	-0,9	50,5	25,5	-1,0	16	1,5	0,3	18,1	3,47	0,4800	UI 48b
52.055	SU 60a	U 4.1	103,6	60,1	19,8	-0,9	63,0	20,6	-1,1	20	2,0	0,3	22,6	3,50	0,6050	UI 60a
52.060	SU 60b	U 4.2	103,6	60,1	19,8	-0,9	63,0	30,6	-1,1	20	2,0	0,3	22,6	5,30	0,9160	UI 60b
52.065	SU 75a	U 5.1	128,6	75,0	24,7	-1,0	78,0	26,1	-1,1	25	2,0	0,3	28,2	5,63	1,2100	UI 75a
52.070	SU 75b	U 5.2	128,6	75,0	24,7	-1,0	78,0	41,1	-1,1	25	2,0	0,3	28,2	9,01	1,9400	UI 75b
52.075	SU 90a	U 6.1	155,8	90,0	29,6	-1,1	95,0	30,9	-1,4	30	3,0	0,5	34,0	7,99	2,0800	UI 90a
52.080	SU 90b	U 6.2	155,8	90,0	29,6	-1,1	95,0	50,9	-1,4	30	3,0	0,5	34,0	13,40	3,4900	UI 90b
52.085	SU 102a	U 7.1	175,4	102,4	33,7	-1,2	106,0	35,4	-1,4	34	3,0	0,5	38,4	10,50	3,0800	UI 102a
52.090	SU 102b	U 7.2	175,4	102,4	33,7	-1,2	106,0	56,4	-1,4	34	3,0	0,5	38,4	17,00	4,9900	UI 102b
52.095	SU 114a	U 8.1	195,6	114,4	37,6	-1,3	118,0	39,2	-1,7	38	3,0	0,6	42,8	12,90	4,2300	UI 114a
52.100	SU 114b	U 8.2	195,6	114,4	37,6	-1,3	118,0	63,2	-1,7	38	3,0	0,6	42,8	21,20	6,9600	UI 114b
52.105	SU 132a	U 9.1	225,4	132,1	43,4	-1,4	136,0	45,2	-1,7	44	3,0	0,6	49,5	17,40	6,5900	UI 132a
52.110	SU 132b	U 9.2	225,4	132,1	43,4	-1,4	136,0	71,2	-1,7	44	3,0	0,6	49,5	27,70	10,4900	UI 132b
52.115	SU 150a	U 10.1	255,6	150,2	49,4	-1,5	154,0	51,2	-1,7	50	3,0	0,6	56,2	22,50	9,6700	UI 150a
52.120	SU 150b	U 10.2	255,6	150,2	49,4	-1,5	154,0	76,2	-1,7	50	3,0	0,6	56,2	33,90	14,5700	UI 150b
52.125	SU 168a	U 11.1	286,0	168,3	55,3	-1,6	172,0	57,0	-2,0	56	3,0	0,6	63,0	28,10	13,5400	UI 168a
52.130	SU 168b	U 11.2	286,0	168,3	55,3	-1,6	172,0	91,0	-2,0	56	3,0	0,6	63,0	45,40	21,8800	UI 168b
52.135	SU 180a	U 12.1	307,2	181,3	59,7	-1,8	184,0	62,0	-2,0	60	3,0	0,6	67,6	33,00	17,0700	UI 180a
52.140	SU 180b	U 12.2	307,2	181,3	59,7	-1,8	184,0	77,0	-2,0	60	3,0	0,6	67,6	41,30	21,3600	UI 180b
52.145	SU 180c	U 12.3	307,2	181,3	59,7	-1,8	184,0	92,0	-2,0	60	3,0	0,6	67,6	49,50	25,6000	UI 180c
52.150	SU 210a	U 13.1	357,2	211,2	69,6	-2,0	214,0	71,7	-2,2	70	3,0	0,6	78,7	44,60	26,8500	UI 210a
52.155	SU 210b	U 13.2	357,2	211,2	69,6	-2,0	214,0	101,7	-2,2	70	3,0	0,6	78,7	63,90	38,4700	UI 210b
52.160	SU 210c	U 13.3	357,2	211,2	69,6	-2,0	214,0	131,7	-2,2	70	3,0	0,6	78,7	83,20	50,0900	UI 210c
52.170	SU 240a	U 14.1	406,2	242,2	79,6	-2,0	243,0	81,7	-2,2	80	3,0		89,8	58,60	40,3000	UI 240a
52.175	SU 240b	U 14.2	406,2	242,2	79,6	-2,0	243,0	108,7	-2,2	80	3,0		89,8	78,50	54,0000	UI 240b
52.180	SU 240c	U 14.3	406,2	242,2	79,6	-2,0	243,0	139,7	-2,2	80	3,0		89,8	101,00	69,2000	UI 240c

SCHNITTBANDKERNE S3U/ SPLIT TAPE CORES S3U

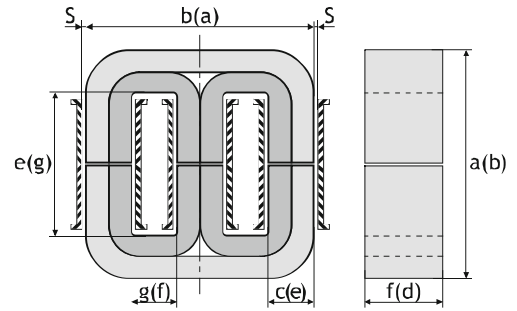

Angaben in (...) = IEC 60329 Bemassung
 Descripton in (...) = IEC 60329 dimension

Abmessungen (mech. Daten)/ Dimensions (mechanical data)

Bestell-Nr. Order-No.	Typ DIN	Typ IEC	a	b	c	c	e	f	f	g	r	s	l_{Fe}	A_{FE}	m_{FE}	zugehörige Spulenkörper
			max.	max		zul. Abw.	min.		zul. Abw.	min.	max.					
			mm	mm	mm	mm	mm	mm	mm	mm	mm	mm	cm	cm ²	kg	Type u. Größe type and size
54.005	S3U 30a	3U 1.1	53,7	50,9	9,9	-0,8	32,5	10,1	-0,6	10	1,5	0,3	18,4	0,82	0,115	UI 30a
54.010	S3U 30b	3U 1.2	53,7	50,9	9,9	-0,8	32,5	16,1	-0,6	10	1,5	0,3	18,4	1,34	0,188	UI 30b
54.015	S3U 39a	3U 2.1	68,9	66,0	12,9	-0,8	41,5	13,4	-0,9	13	1,5	0,3	23,8	1,44	0,261	UI 39a
54.020	S3U 39b	3U 2.2	68,9	66,0	12,9	-0,8	41,5	20,4	-0,9	13	1,5	0,3	23,8	2,24	0,407	UI 39b
54.025	S3U 48a	3U 3.1	83,9	80,8	15,8	-0,9	50,5	16,5	-1,0	16	1,5	0,4	29,1	2,19	0,491	UI 48a
54.030	S3U 48b	3U 3.2	83,9	80,8	15,8	-0,9	50,5	25,5	-1,0	16	1,5	0,4	29,1	3,47	0,776	UI 48b
54.035	S3U 60a	3U 4.1	104,6	100,9	19,8	-0,9	63,0	20,6	-1,1	20	2,0	0,4	36,4	3,50	0,977	UI 60a
54.040	S3U 60b	3U 4.2	104,6	100,9	19,8	-0,9	63,0	30,6	-1,1	20	2,0	0,4	36,4	5,30	1,470	UI 60b
54.045	S3U 75a	3U 5.1	129,7	125,7	24,7	-1,0	78,0	26,1	-1,1	25	2,0	0,4	45,2	5,63	1,960	UI 75a
54.050	S3U 75b	3U 5.2	129,7	125,7	24,7	-1,0	78,0	41,1	-1,1	25	2,0	0,4	45,2	9,01	3,130	UI 75b
54.055	S3U 90a	3U 6.1	156,8	150,6	29,6	-1,1	95,0	30,9	-1,4	30	3,0	0,5	54,5	7,99	3,330	UI 90a
54.060	S3U 90b	3U 6.2	156,8	150,6	29,6	-1,1	95,0	50,9	-1,4	30	3,0	0,5	54,5	13,40	5,590	UI 90b
54.065	S3U 102a	3U 7.1	176,4	171,1	33,7	-1,2	106,0	35,4	-1,4	34	3,0	0,5	61,6	10,50	4,940	UI 102a
54.070	S3U 102b	3U 7.2	176,4	171,1	33,7	-1,2	106,0	56,4	-1,4	34	3,0	0,5	61,6	17,00	8,000	UI 102b
54.075	S3U 114a	3U 8.1	196,2	191,0	37,6	-1,3	118,0	39,2	-1,7	38	3,0	0,6	68,7	12,90	6,790	UI 114a
54.080	S3U 114b	3U 8.2	196,2	191,0	37,6	-1,3	118,0	63,2	-1,7	38	3,0	0,6	68,7	21,20	11,140	UI 114b
54.085	S3U 132a	3U 9.1	226,4	220,5	43,4	-1,4	136,0	45,2	-1,7	44	3,0	0,6	79,4	17,40	10,540	UI 132a
54.090	S3U 132b	3U 9.2	226,4	220,5	43,4	-1,4	136,0	71,2	-1,7	44	3,0	0,6	79,4	27,70	16,840	UI 132b
54.095	S3U 150a	3U 10.1	255,6	249,6	49,4	-1,5	154,0	51,2	-1,7	50	3,0	0,6	90,2	22,50	15,500	UI 150a
54.100	S3U 150b	3U 10.2	255,6	249,6	49,4	-1,5	154,0	76,2	-1,7	50	3,0	0,6	90,2	33,90	23,400	UI 150b
54.105	S3U 168a	3U 11.1	286,0	279,6	55,3	-1,6	172,0	57,0	-2,0	56	3,0	0,8	101,0	28,10	21,700	UI 168a
54.110	S3U 168b	3U 11.2	286,0	279,6	55,3	-1,6	172,0	91,0	-2,0	56	3,0	0,8	101,0	45,40	35,100	UI 168b
54.115	S3U 180a	3U 12.1	307,2	301,0	59,7	-1,8	184,0	62,0	-2,0	60	3,0	0,8	108,5	33,00	27,400	UI 180a
54.120	S3U 180b	3U 12.2	307,2	301,0	59,7	-1,8	184,0	77,0	-2,0	60	3,0	0,8	108,5	41,30	34,200	UI 180b
54.125	S3U 180c	3U 12.3	307,2	301,0	59,7	-1,8	184,0	92,0	-2,0	60	3,0	0,8	108,5	49,50	41,100	UI 180c
54.130	S3U 210a	3U 13.1	357,2	350,8	69,6	-2,0	214,0	71,7	-2,2	70	3,0	0,8	126,3	44,60	43,100	UI 210a
54.135	S3U 210b	3U 13.2	357,2	350,8	69,6	-2,0	214,0	101,7	-2,2	70	3,0	0,8	126,3	63,90	61,700	UI 210b
54.140	S3U 210c	3U 13.3	357,2	350,8	69,6	-2,0	214,0	131,7	-2,2	70	3,0	0,8	126,3	83,10	80,400	UI 210c
54.145	S3U 240a	3U 14.1	406,2	400,8	79,6	-2,0	243,0	81,7	-2,2	80	3,0	0,8	144,0	58,60	64,600	UI 240a
54.150	S3U 240b	3U 14.2	406,2	400,8	79,6	-2,0	243,0	108,7	-2,2	80	3,0	0,8	144,0	78,50	86,500	UI 240b
54.155	S3U 240c	3U 14.3	406,2	400,8	79,6	-2,0	243,0	138,7	-2,2	80	3,0	0,8	144,0	101,00	111,000	UI 240c

SCHNITTBANDKERNE SG/ SPLIT TAPE CORES SG

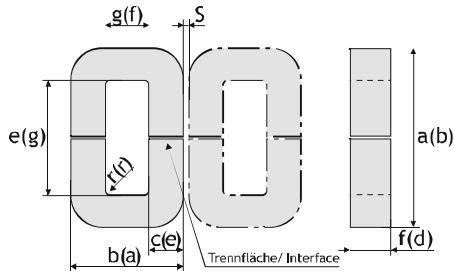

Angaben in (...) = IEC 60329 Bemaßung/ Descripton in (...) = IEC 60329 dimension

Bestell-Nr. Order-No.	Typ DIN Type DIN	Typ IEC Type IEC	a	a zul. Abw. a Perm. dev.	b max.	c	c zul. Abw. c Perm. dev.	e min.	f	f zul. Abw. f Perm. dev.	g min.	r max.	s	l_{Fe}	A_{FE}	m_{FE}	zugehörige Spulenkörper Matching bobbin
			mm	mm	mm	mm	mm	mm	mm	mm	mm	mm	mm	cm	cm ²	kg	Type u. Größe type and size
53.005	SG 27/6 ¹⁾	Q 1.1	29,4	-2,4	21,0	7,2	-0,8	14,3	7,2	-0,8	6,4	1,0	0,4	6,32	0,372	0,0180	SG 27-6
53.010	SG 33/7 ¹⁾	Q 2.1	35,7	-2,4	25,8	8,7	-0,8	17,5	8,7	-0,8	7,9	1,0	0,4	7,77	0,582	0,0347	SG 33-7
53.015	SG 41/9	Q 3.1	43,7	-2,4	30,6	10,3	-0,8	22,2	10,3	-0,8	9,5	1,0	0,4	9,53	0,862	0,0630	SG 41-9
53.020	SG 48/9	Q 4.1	50,0	-2,4	32,1	10,3	-0,8	28,6	10,3	-0,8	11,1	1,0	0,4	11,10	0,862	0,0735	SG 48-9
53.025	SG 54/13	Q 5.1	56,4	-2,4	30,6	8,7	-0,8	38,1	13,5	-0,8	12,7	1,5	0,4	12,80	0,960	0,0940	SG 54-13
53.030	SG 54/19	Q 5.2	56,4	-2,4	30,6	8,7	-0,8	38,1	19,8	-0,8	12,7	1,5	0,4	12,80	1,440	0,1410	SG 54-19
53.035	SG 54/25	Q 5.3	56,4	-2,4	30,6	8,7	-0,8	38,1	26,2	-0,8	12,7	1,5	0,4	12,80	1,920	0,1870	SG 54-25
53.040	SG 54/38	Q 5.4	56,4	-2,4	30,6	8,7	-0,8	38,1	38,9	-0,8	12,7	1,5	0,4	12,80	2,880	0,2810	SG 54-38
53.045	SG 70/13	Q 6.1	73,0	-3,2	36,9	10,3	-0,8	50,8	13,5	-0,8	15,9	1,5	0,4	16,50	1,150	0,1450	SG 70-13
53.050	SG 70/19	Q 6.2	73,0	-3,2	36,9	10,3	-0,8	50,8	19,8	-0,8	15,9	1,5	0,4	16,50	1,720	0,2180	SG 70-19
53.055	SG 70/25	Q 6.3	73,0	-3,2	36,9	10,3	-0,8	50,8	26,2	-0,8	15,9	1,5	0,4	16,50	2,300	0,2910	SG 70-25
53.060	SG 70/32	Q 6.4	73,0	-3,2	36,9	10,3	-0,8	50,8	32,5	-0,8	15,9	1,5	0,4	16,50	2,870	0,3630	SG 70-32
53.065	SG 76/19	Q 7.1	79,4	-3,2	40,1	10,3	-0,8	57,2	19,8	-0,8	19,0	3,0	0,4	18,10	1,720	0,2390	SG 76-19
53.070	SG 76/25	Q 7.2	79,4	-3,2	40,1	10,3	-0,8	57,2	26,2	-0,8	19,0	3,0	0,4	18,10	2,300	0,3190	SG 76-25
53.075	SG 76/32	Q 7.3	79,4	-3,2	40,1	10,3	-0,8	57,2	32,5	-0,8	19,0	3,0	0,4	18,10	2,870	0,3980	SG 76-32
53.080	SG 76/38	Q 7.4	79,4	-3,2	40,1	10,3	-0,8	57,2	38,9	-0,8	19,0	3,0	0,4	18,10	3,450	0,4780	SG 76-38
53.085	SG 89/22	Q 8.1	92,1	-3,2	49,6	13,5	-0,8	63,5	23,0	-0,8	22,2	3,0	0,6	21,10	2,680	0,4320	SG 89-22
53.090	SG 89/29	Q 8.2	92,1	-3,2	49,6	13,5	-0,8	63,5	29,4	-0,8	22,2	3,0	0,6	21,10	3,450	0,5530	SG 89-29
53.095	SG 89/38	Q 8.3	92,1	-3,2	49,6	13,5	-0,8	63,5	38,9	-0,8	22,2	3,0	0,6	21,10	4,600	0,7390	SG 89-38
53.100	SG 89/51	Q 8.4	92,1	-3,2	49,6	13,5	-0,8	63,5	51,6	-0,8	22,2	3,0	0,6	21,10	6,130	0,9890	SG 89-51
53.105	SG 108/19	Q 9.1	111,1	-3,2	62,3	16,7	-0,8	76,2	19,8	-0,8	28,6	3,0	0,6	25,90	2,870	0,5670	SG 108-19
53.110	SG 108/29	Q 9.2	111,1	-3,2	62,3	16,7	-0,8	76,2	29,4	-0,8	28,6	3,0	0,6	25,90	4,540	0,8960	SG 108-29
53.115	SG 108/38	Q 9.3	111,1	-3,2	62,3	16,7	-0,8	76,2	38,9	-0,8	28,6	3,0	0,6	25,90	5,750	1,1380	SG 108-38
53.120	SG 108/51	Q 9.4	111,1	-3,2	62,3	16,7	-0,8	76,2	51,6	-0,8	28,6	3,0	0,6	25,90	7,660	1,5150	SG 108-51
53.125	SG 127/25	Q 10.1	130,2	-3,2	75,0	19,8	-0,8	88,9	26,2	-0,8	34,9	3,0	0,6	30,70	4,600	1,0790	SG 127-25
53.130	SG 127/38	Q 10.2	130,2	-3,2	75,0	19,8	-0,8	88,9	38,9	-0,8	34,9	3,0	0,6	30,70	6,900	1,6190	SG 127-38
53.135	SG 127/51	Q 10.3	130,2	-3,2	75,0	19,8	-0,8	88,9	51,6	-0,8	34,9	3,0	0,6	30,70	9,230	2,1630	SG 127-51
53.140	SG 127/70	Q 10.4	130,2	-3,2	75,0	19,8	-0,8	88,9	71,4	-1,6	34,9	3,0	0,6	30,70	12,650	2,9660	SG 127-70
53.145	SG 165/32	Q 11.1	169,9	-4,7	97,2	26,2	-0,8	114,3	32,5	-0,8	44,4	3,0	1,0	40,20	7,680	2,3630	SG 165-32
53.150	SG 165/51	Q 11.2	169,9	-4,7	97,2	26,2	-0,8	114,3	51,6	-0,8	44,4	3,0	1,0	40,20	12,260	3,7730	SG 165-51

1) Nur in 0,1 mm Banddicke lieferbar.

1) Available in 0,1 mm Tape thickness only

SONDERFORM SCHNITTBANDKERNE SPECIAL SPLIT TAPE CORE DESIGNS

SCHNITTBANDKERNE (SONDERFORMEN) SPLIT TAPE CORE DESIGNS (SPECIAL SHAPES)

Der Eckenradius der Wickelkörper beträgt ca. 3 mm.
Die Kerne werden normalerweise im Verhältnis 1:1 getrennt.
Bei Sonderwünschen bitte genaue Angaben über die Schnittlage.

The Corner radius of the winding forms is approx. 3 mm.
The cores are normally cut in the ratio 1:1.
For special requirements please give detail of the exact position of cut.

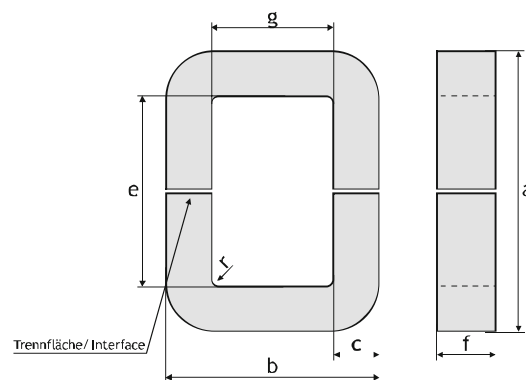

Angaben in (...) = IEC 60329 Bemaßung/ Descripton in (...) = IEC 60329 dimension

Maßtoleranzen für Schnittbandkerne in Sonderformen Tolerances for special designs

Nennabmessungen Nominal dimensions		Toleranzen für Tolerances for				
a mm	c mm	a mm	b mm	e mm	g mm	f mm
≤ 30	< 5	+ 1,5 0	+ 1,0 0	0 -1,0	0 -1,0	+ 0,5 0
≤ 100	< 25	+ 2,0 0	+ 1,5 0	0 -1,5	0 -1,5	+ 1,0 0
≤ 160	≤ 35	+3,0 0	+ 2,0 0	0 - 2,0	0 -1,5	+1,0 0
≤ 160	> 35	+4,0 0	+ 3,0 0	0 -2,0	0 -1,5	+ 1,2 0
> 160	≤ 35	+4,0 0	+ 3,0 0	0 -3,0	0 -1,5	+ 1,2 0
> 160	> 35	+ 5,0 0	+ 4,0 0	0 -3,0	0 -2,0	+ 1,5 0
> 300	> 40	+ 6,0 0	+ 5,0 0	0 - 4,0	0 - 3,0	+ 2,5 0



GARANTIE FÜR SCHNITTBANDKERNE

Schnittbandkerne werden vorwiegend aus dem Werkstoff C 5 in 0,3 mm Banddicke gefertigt.

Die Garantie-Nr. 109, 110, 111 haben gestufte zulässige Höchstwerte für spezifischen Kernverlust PFe und spezifische Scheinleistung Ps (siehe nachstehende Tabelle).

Garantie-Nr. 111 die Trennflächen werden nach dem Schleifen zusätzlich verfeinert. Luftspalt wird somit herabgesetzt (Schnittqualität C).

Garantie-Nr. 112 ist für Kerne mit hohen Meßfrequenzen.

Garantie-Nr. 120 ist vorwiegend für Schnittbandkerne die im Schweißtrafo verarbeitet werden.

GUARANTEES FOR SPLIT TAPE CORES

For the most part the split tape cores are manufactured from material in 0,3 mm tape thickness.

The guarantee numbers 109, 110, and 111 have graduated permissible maximum values for specific core loss PFe and specific apparent output Ps (see following table).

For guarantee number 111 the interface are additionally super finished after grinding. So the air gap dimension is decreased (cut quality C).

Guarantee number 112 is for cores with high measuring frequencies.

For the most part guarantee number 120 is for split tape cores used in welding transformers.

Werkstoff Material	Ausführung Design	Garantie-Nummer Guarantee-number	Banddicke Tape thickness mm	Meßfrequenz Measuring frequency Hz	magnetische Feldstärke Magnetic field strength	Werte für runde Kerne, für rechteckige Kerne 10% niedrigere Werte Values for round cores 10% less for square cores			
						Mindestinduktion (Tesla) für Kerngröße I _{Fe} = Minimum induction (Tesla) for core sizes I _{Fe} =			
						10 cm	20 cm	40 cm	80 cm
C5 Korno	„A“	C5-104*	0,3	50	0,03 Aeff/cm	0,0200	0,0220	0,0235	0,0245
					0,3 Aeff/cm	0,5100	0,6700	0,7900	0,8700
					10,0 Aeff/cm	1,6600	1,7100	1,7250	1,7400

* Diesen Garantien liegt der geometrische Kernquerschnitt zugrunde, allen übrigen der kleinstmögliche Eisenquerschnitt.

* These guarantees are based on geometrical core cross-section, all others on minimum iron cross-section

Werkstoff Material	Ausführung Design	Garantie-Nummer Guarantee-number	Banddicke Tape thickness mm	Meßfrequenz Measuring frequency Hz	\hat{B} Bezugsinduktion \hat{B} Reference induction Tesla	höchstzulässige Verluste max. permissible losses (W/kg)	Höchstzulässige Scheinleistung (VA/kg) für I _{Fe} = max. permissible apparent output for (VA/kg) I _{Fe} =				
							5 cm	10 cm	20 cm	40 cm	80 cm
C5 Korno	„A“	C5-109	0,3	50	1,7	2,2	-	27,3	20,2	16,7	14,9
C5 Korno	„A“	C5-110	0,3	50	1,7	2,0	-	18,5	13,8	11,5	10,4
C5 Korno	„C“	C5-111	0,3	50	1,7	1,8	-	10,4	8,1	6,9	6,4
C5 Korno	„C“	C5-115**2)	0,3	50	1,7	1,7	-	-	5,0	4,4	4,2
C5 Korno	„C“	C5-112	0,1	400	1,0	10(12) ¹⁾	34	24,0	21,0	19,5	19,0
C5 Korno	„C“	C5-112	0,05	2000	0,5	20(25) ¹⁾	72	43,0	40,0	38,0	37,0

** Sonderqualität

** Special quality

Werkstoff Material	Ausführung Design	Garantie-Nummer Guarantee-number	Banddicke Tape thickness mm	Meßfrequenz Measuring frequency Hz	\hat{B} Bezugsinduktion \hat{B} Reference induction Tesla	höchstzulässige Verluste max. permissible losses (W/kg)	Höchstzulässige Feldstärke (Aeff/cm) für I _{Fe} = max. permissible apparent output (Aeff/cm) for I _{Fe} =		
							20 cm	40 cm	80 cm
C5 Korno	„A“	C5-120 ³⁾	0,3	50	1,9	3,5	5,5	4,8	4,4

¹⁾ Für Kerne mit I_{Fe} < 10 cm.

²⁾ Sondergarantie für Magnetverstärker-Kerne.

³⁾ Garantie für Schweißtrafo-Kerne

¹⁾ For cores with I_{Fe} < 10 cm.

²⁾ Special guarantee for magnetic amplifier cores.

³⁾ Guarantee for welding transformer cores

IHRE NOTIZEN/ YOUR NOTES

Details und weitere Informationen können sie auf unserer Internetseite finden.
Details and further information you will find on our web-site

<http://www.waasner.de>





RINGBANDKERNE TOROIDAL TAPE CORES

RINGBANDKERNE/ TOROIDAL TAPE CORES

RINGSCHNITTKERNE/ ROUND SPLIT CORES

SONDERFORMEN (RINGBANDKERNE)/ SPECIAL SHAPES (TOROIDAL TAPE)

WERKSTOFFE UND MAGNETQUALITÄTEN/ MATERIAL CLASS AND MAGNETIC QUALITY





RINGBANDKERNE/ TOROIDAL TAPE CORES

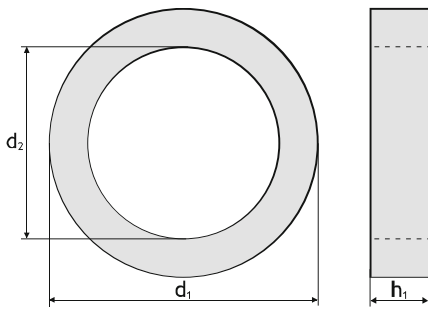

Maßtoleranzen für Ringbandkerne

Innen-durchmesser d ₂	zulässige Abweichungen	Außen-durchmesser d ₁	zulässige Abweichungen	zulässige Höhenabweichungen
≤ 10	± 0,30	≤ 10	± 0,40	+ 0,3
≤ 25	± 0,50	≤ 25	± 0,60	+ 0,4
≤ 50	± 0,50	≤ 50	± 1,00	+ 0,6
≤ 80	± 0,75	≤ 80	± 1,25	+ 0,8
≤ 100	± 1,00	≤ 100	± 1,50	+ 1,0
≤ 160	± 1,30	≤ 160	± 2,00	+ 1,5
≤ 200	± 1,50	≤ 200	± 2,50	+ 1,5
≤ 320	± 2,00	≤ 320	± 3,00	+ 2,0
≤ 500	± 2,50	≤ 500	± 4,00	+ 2,5

Die Unrundheit ist in den Durchmesser-toleranzen enthalten. Bei den Kernen mit $(d_1 - d_2) / 2 \leq 10$ mm aus Bändern von 0,3mm Dicke erhöhen sich die Durchmesser-toleranzen um +0,3mm.

Tolerances for Toroidal Tape Cores

Inside diameter d ₂	Permissible deviation	Outside diameter d ₁	Permissible deviation	Permissible deviation of height
≤ 10	± 0,30	≤ 10	± 0,40	+ 0,3
≤ 25	± 0,50	≤ 25	± 0,60	+ 0,4
≤ 50	± 0,50	≤ 50	± 1,00	+ 0,6
≤ 80	± 0,75	≤ 80	± 1,25	+ 0,8
≤ 100	± 1,00	≤ 100	± 1,50	+ 1,0
≤ 160	± 1,30	≤ 160	± 2,00	+ 1,5
≤ 200	± 1,50	≤ 200	± 2,50	+ 1,5
≤ 320	± 2,00	≤ 320	± 3,00	+ 2,0
≤ 500	± 2,50	≤ 500	± 4,00	+ 2,5

The non-circularity is included in the diameter tolerances. For cores with $(d_1 - d_2) / 2 \leq 10$ mm made of tapes with 0.3 mm thickness, the diameter tolerances are increased by + 0,3 mm.

Banddicke mm	Füllfaktor η
	Stahl mit 3% Si
0,27 bis/to 0,35	0,95
0,10	0,92
0,05	0,88

Tape thickness mm	Fill Factor η
	Steel with 3% Si
0,27 bis/to 0,35	0,95
0,10	0,92
0,05	0,88



GEBRÜDER WAASNER
 Elektrotechnische Fabrik GmbH
 Bamberger Straße 85 · D-91301 Forchheim

Tel.: +49 (0) 91 91 - 6 12-0 · Fax: +49 (0) 91 91 - 6 79 91
 Mail: info@waasner.de

RINGBANDKERNE

Verschiedene Verfestigungsarten und Formen von Ringbandkernen

	Bez. nach WAA
Ringbandkern mit einem allseitigen öl- und temperaturbeständigen Lacküberzug.	= L
Ringbandkern imprägniert in einem schrumpfarmen Tränklack (erhöhte mechanische Festigkeit).	= F
Ringbandkern imprägniert mit zusätzlich temperaturbeständigem Lacküberzug.	= FL
Ringbandkern mit Kunststoffüberzug. Schichtdicke ca. 0,05 mm bis 2 mm. Der Überzug wird im Wirbelsinterverfahren aufgebracht. Bei dieser Art ist es möglich, den Ringbandkern ohne zusätzliche Isolation zu bewickeln.	= S
Kunststoffkappen für Ringbandkerne können als Grundisolation zum direkten Bewickeln verwendet werden.	= K
Ringbandkern unlackiert.	= U
Ringbandkern verklebt.	= V

TOROIDAL TAPE CORES

Several kinds of reinforcement and toroidal tape core forms

	WAA Typ
Toroidal tape core with oil and temperature-resistant varnish coat on all sides.	= L
Toroidal tape core, impregnated with a low-contraction impregnation varnish (increased mechanical strength).	= F
Toroidal tape core, impregnated with additional temperature-resistant varnish coat.	= FL
Toroidal tape core with synthetic coat. Layer thickness approx. 0,05 mm to 2 mm. The coat is applied with whirl-sintering method. This method allows the winding of the toroidal tape core without additional insulation.	= S
Plastic shrouds for toroids may be used as basic insulation for direct application of coil windings.	= K
Toroidal tape core without varnish	= U
Toroidal tape core bonded	= V

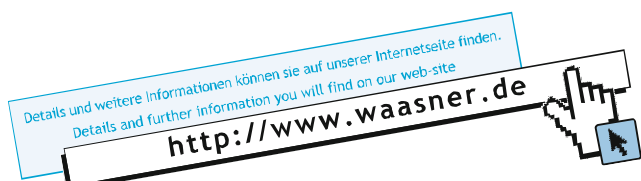



RINGSCHNITTKERNE

(=Runde - Schnittbandkerne)

Zur Bestellung der Kerne sind

- a) Innendurchmesser
- b) Außendurchmesser
- c) Banddicke
- d) Kernhöhe

anzugeben, z.B. 100 x 125 - 0,3 x 15 mm

ROUND - SPLIT CORES

(=round - split cores)

- a) Inside diameter
- b) Outside diameter
- c) Tape thickness
- d) Core height

must be indicated when ordering the cores,

e.g. 100 x 125 - 0.3 x 15 mm

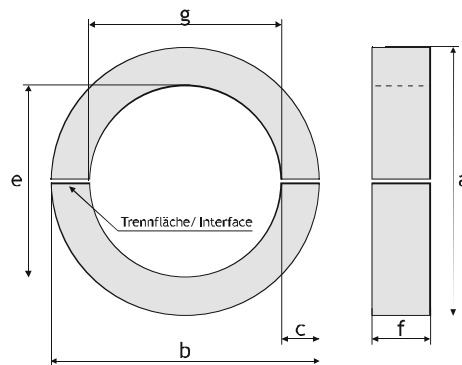

Maßtoleranzen für Ringschnittkerne

Innendurchmesser	Außendurchmesser	Toleranzen für					
		a	b	c	e	f	g
		mm	mm	mm	mm	mm	mm
> 35 - 60	50 - 75	± 2,0	± 2,0	± 0,4	± 2,0	+ 1,0	± 2,0
> 50 - 120	> 75 - 150	± 2,0	± 2,0	± 0,6	± 2,0	+ 1,5	± 2,0
> 100 - 200	> 150 - 250	+ 2,0 - 3,0	± 3,0	± 1,0	+ 2,0 - 3,0	+ 2,0	± 2,0
> 165 - 280	> 250 - 350	+ 2,0 - 3,0	± 3,0	± 1,0	+ 2,0 - 3,0	+ 3,0	± 3,0

Tolerances for „Round“ split tape cores

Inside diameter	Outside diameter	Tolerances for					
		a	b	c	e	f	g
		mm	mm	mm	mm	mm	mm
> 35 - 60	50 - 75	± 2,0	± 2,0	± 0,4	± 2,0	+ 1,0	± 2,0
> 50 - 120	> 75 - 150	± 2,0	± 2,0	± 0,6	± 2,0	+ 1,5	± 2,0
> 100 - 200	> 150 - 250	+ 2,0 - 3,0	± 3,0	± 1,0	+ 2,0 - 3,0	+ 2,0	± 2,0
> 165 - 280	> 250 - 350	+ 2,0 - 3,0	± 3,0	± 1,0	+ 2,0 - 3,0	+ 3,0	± 3,0

SONDERFORMEN (RINGBANDKERNE)/ SPECIAL SHAPES (TOROIDAL TAPE)

SONDERANFERTIGUNGEN

Wir liefern Ringbandkerne auch als ovale, rechteckähnliche Bandkerne oder andere Formen. Hierfür sind allerdings besondere Wickel- und Glühvorrichtungen erforderlich. Im allgemeinen werden keine so hohe magnetische Qualitäten erreicht wie bei Ringbandkernen.

SPECIAL CONSTRUCTION

We also supply toroidal tape cores as oval and square tape cores or in other forms. However, special winding and annealing devices are required. In the general the magnetic qualities are not as high as for toroidal tape cores.

STUFENKERNE

Insbesondere bei Übertragern oder Wandlern bei denen hohe Isolationsfestigkeit zwischen den Wicklungen oder zwischen Kern und Wicklung erfordert werden, kann es aus bewicklungstechnischen Gründen zweckmäßig sein, den Kernquerschnitt der Kreisform anzunähern. Wir liefern für solche Anwendungen Kerne mit gestuftem Querschnitt.

GRADUATED CORES

For technical reasons it may be expedient to bring the core cross-section as close as possible to a circular form, especially for transformers requiring high insulating strength between the winding or between core and winding. For these purposes we deliver cores with graduated cross-sections.

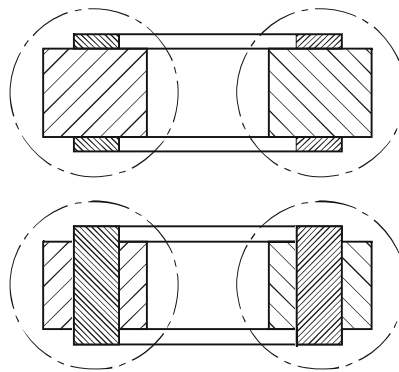

GESCHERTE RINGBANDKERNE

(mit einem Luftspalt)

Zum Beispiel für Übertrager und Speicher-Drosseln (spezielle Anwendungen) ist es erforderlich, in den magnetisch geschlossenen Kreis des Ringbandkernes mit der mittleren Eisenweglänge l_F einen Luftspalt l_L einzubringen (siehe Abbildung). Dieser Luftspalt bewirkt eine Scherung (Abflachung) der Magnetisierungskurve und damit eine Linearisierung.

SHEARED TOROIDAL TAPE CORES

(with an airgap)

For example for transformers and storage inductors (special purposes) it is necessary to provide an air gap l_L in the magnetic closed circuit of the toroidal tape core with an average magnetic circuit length l_F (see figure). This air gap causes shearing (leveling off) of the magnetization curve and so linearization.

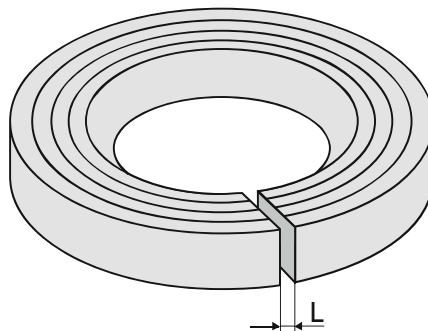

WERKSTOFFE FÜR RINGBANDKERNE

WERKSTOFFE:

Magnetische Werkstoffe sind DIN EN 10 107 festgelegt. Für Ringbandkerne nach dieser Norm kommen hauptsächlich die Werkstoffe nach untenstehender Tabelle in Frage.

MATERIAL CLASS FOR TOROIDAL TAPE CORES

MATERIAL:

Magnetic materials are defined in DIN EN 10 107. For the most part the materials listed in the table below apply for toroidal tape cores as per this standard.

Bezeichnung nach		Nennstärke	Ummagnetisierungsverluste bei 50 HZ W/kg bei		Magnetische Polarisation T, min. im Wechselfeld bei einer magnetischen Feldstärke in A/m von	Stapelfaktor
Designation acc. to		Nominal thickness	Magnetic reversal losses at 50 HZ W/kg at		Magnetic polarisation T, min. in alternating field at a magnetic field strength in A/m of	Stacking factor
EN 10107	Nr. / No.	mm	1,5T max.	1,7T max.	800	min.
M 165-35S (M 111-35N)	1.0856	0,35	1,11	1,65	1,75	0,960
M 150-30S (M 097-30N)	1.0861	0,30	0,97	1,50	1,75	0,955
M 111-30P	1.0881	0,30		1,11	1,88	0,955
M 105-30P	1.0886	0,30		1,05	1,88	0,955

Ferner werden verarbeitet: kornorientiert 0,10 mm
kornorientiert 0,05 mm

Also available: grain oriented 0,10 mm
grain oriented 0,05 mm

WERKSTOFFE

mit verbesserten magnetischen Eigenschaften.
Bessere magnetische Eigenschaften bietet unsere Qualität
M 111-30P und M 105-30P. Hierdurch ergeben sich

- kleiner Ummagnetisierungsverluste bei hohen Induktionen
- höhere Permeabilität
- kleinere Scheinleistung
- kleine Magnetostriktion

ERGEBNIS:

Ringbandkerne mit kleinem Leerlaufstrom, Ringbandkerne mit großer Typenleistung.

MATERIALS

with improved magnetic characteristics.
Our quality M 111-30P and M 105-30P provides better magnetic characteristics. This leads to

- lower magnetic losses at high inductions
- higher permeability
- lower apparent output
- lower magnetostriction

RESULT:

Toroidal tape cores with a low no-load current, toroidal tape cores with high type capacity.

MAGNETQUALITÄTEN FÜR RINGBANDKERNE

Elektrische Garantiewerte in untenstehender Tabelle verstehen sich für geglähte Ringbandkerne ohne jegliche Weiterverarbeitung.

Für z.B. fixierte, imprägnierte, gescherte, gesinterte...Ringbandkerne bitte Garantiewerte bei Bestellung mit uns vereinbaren.

MAGNETIC QUALITIES FOR TOROIDAL TAPE CORES

The guaranteed electrical values of the table below apply to annealed toroidal tape cores without any further processing.

For e.a. fixed, impregnated, sheared, sintered...toroidal tape cores please arrange guaranteed values with us when placing the order.

Werkstoff	Qualität	Magnetqualität	Banddicke (mm)	Meßfrequenz	eff. Feldstärke	Mindestinduktion \hat{B}
Material	Quality	Magnetic-quality	Tapethickness (mm)	Measuringfrequency	Effective field strength	Minimum induction \hat{B}
C 5	X	C 5 - 03	0,3	50 Hz	0,03 A/cm	0,055 Tesla
					0,30 A/cm	1,3 Tesla
					1,00 A/cm	1,7 Tesla
C 5	XX	C 5 - 06	0,3	50 Hz	0,03 A/cm	0,075 Tesla
					0,30 A/cm	1,4 Tesla
C 5	XXX	C 5 - 20	0,3	50 Hz	0,03 A/cm	0,1 Tesla
					0,30 A/cm	1,6 Tesla
					1,00 A/cm	1,75 Tesla
Werkstoff	Qualität	Magnetqualität	Banddicke (mm)	Meßfrequenz	Induktion \hat{B}	höchstzulässige Verluste
Material	Quality	Magnetic-quality	Tapethickness (mm)	Measuringfrequency	Induction \hat{B}	Max. perm. losses
C 5	X	C 5 - 40	0,1	400 Hz	1,0 Tesla	8 W/kg
C 5	X	C 5 - 40	0,05	2 kHz	0,5 Tesla	15 W/kg
C 5	X	C 5 - 40	0,025	10 kHz	0,3 Tesla	60 W/kg

X = Normalqualität
X = standard quality

XX = Sonderqualität
XX = extra quality

XXX = Spezialqualität
XXX = special quality

MAGNETISCHE UND PHYSIKALISCHE EIGENSCHAFTEN MAGNETIC AND PHYSICAL CHARACTERISTICS

Werkstoff	Hauptbestandteil neben Eisen	Durchschnittswerte für Banddicke	Permeabilität		Sättigungsinduktion ¹⁾	Koerzitivfeldstärke stat.	Sättigungsmagnetostraktion	Curie-temp.	Spez. elektr. Widerstand	Dichte	
			Permeability								
Material	Main components apart from iron	Average values for tape thickness	mm	μ (50 Hz)	μ max.(50Hz)	(T)	(A/cm)	x 10 ⁶	(°C)	Ω x mm ² /m	Density
C 5	ca 3% Si	0,30	3000	35000	2,03	0,1	+7...9	750	0,4	7,65	

¹⁾ bei weichmagnetischen Legierungen praktisch mit der Sättigungspolarisation identisch.

¹⁾ Identical to saturation polarization upon low-magnetic alloys.



UNSERE VERTRETUNGEN/ OUR AUTHORIZED REPRESENTATIVES

INLAND/ NATIONAL

HESSEN / HESSE

HARTMUT PAKUSCH
Ing.-Büro für Fertigungstechnik
Märkerstraße 2b
63755 Alzenau
Tel. +49 (0) 6023 - 92 92 09
Fax +49 (0) 6023 - 92 93 09
ib-pakusch@gmx.de

andere Bundesländer / other regions

GEBRÜDER WAASNER
Bamberger Straße 85
91301 Forchheim
Tel. +49 (0) 9191 - 6 12-0
Fax +49 (0) 9191 - 6 79 91
info@waasner.de
http://www.waasner.de



AUSLAND/ INTERNATIONAL

AUSTRIA/ HUNGARY

INS INDUSTRIEREPRÄSENTANZ
Norbert Stanke
Mittelgasse 35
A - 1060 Wien
Tel. +43 - 1 - 26 - 36 05 20
Fax +43 - 1 - 26 - 36 05 212
Mobil +43 - 6 76 38 28 83 5
norbert@stanke.at
<http://www.members.aon.at/ins>

BELGIUM

JBTO BVBA
Helshovenstraat 10
B - 3840 Borgloon
Tel. +32 - 11 - 58 26 65
Fax +32 - 11 - 48 26 44
Mobil +32 - 4 97 50 36 66
jos.boden@jbto.be
<http://www.jbto.be>

CZECH. REPUBLIC

ERMEG S.R.O.
Zitavska 629/ 48
CZ - 46011 Liberec 11
Tel. +420 - 485 - 10 81 48
Fax +420 - 485 - 10 30 77
p.jelinek@ermeg.cz
<http://www.ermeg.cz>

GREECE

N. ASTERIADIS S.A.
54, Tsimiski Str.
GR - 54013 Thessaloniki
P.O.BOX 50330
GR - 54013 Thessaloniki
Tel. +30 - 2310 - 27 86 92
Fax +30 - 2310 - 28 46 91
na@asteriadis.gr
<http://www.asteriadis.gr>

GREECE

N. ASTERIADIS S.A.
31, Dervenion Str.&Poseidonos Str.
GR - 14451 Metamorfossi-Athens
Tel. +30 - 210 - 8 23 53 83
Fax +30 - 210 - 8 23 95 67
salesath@asteriadis.gr
<http://www.asteriadis.gr>

ISRAEL

SHEMER REPRESENTATIONS Ltd.
P.O. Box 296
IL - Yehud 56101
Tel. +972 - 3 - 53 65 167
Fax +972 - 3 - 53 60 581
shemer@shemerep.co.il
<http://www.shemerep.co.il>

NETHERLANDS

WESCAP BV
Veldkampweg 19
NL - 7731 HL Ommen
Tel. +31 - 529 - 46 28 30
Fax +31 - 529 - 46 31 76
info@wescap.nl
<http://www.wescap.nl>

NORWAY

GEBRÜDER WAASNER
Bamberger Straße 85
D-91301 Forchheim
Tel. +49 (0) 9191 - 6 12-0
Fax +49 (0) 9191 - 6 79 91
info@waasner.de
<http://www.waasner.de>

RUSSIA

000 „MILVERTON“
Bertel Henriksson
Ul. Galernaja d 42/32
RUS - 190 000 St. Petersburg
Tel. +7 - 905 - 2 78 06 68
Fax +7 - 812 - 3 14 27 61
Mobil +7 - 905 - 2 85 69 30
bhhenriksson@milvertonllc.com
milvertonllc@milvertonllc.com

SPAIN

MP - TECNOIMPORT S.L.
C/. Cardenal Cisneros, 2 local
E-50002-Zaragoza
Tel. +34 - 976 - 38 06 18
Fax +34 - 976 - 37 89 70
info@mptecnimport.com
<http://www.mptecnimport.com>

SWITZERLAND

GEBRÜDER WAASNER
Bamberger Straße 85
D-91301 Forchheim
Tel. +49 (0) 9191 - 6 12-0
Fax +49 (0) 9191 - 6 79 91
info@waasner.de
<http://www.waasner.de>

UKRAINE

AMBULOV D.P.FOP
ul. Solomenskaja 10-1
UA - 03110 Kiev
Tel. +380 - 67 - 4 05 90 00
Fax +380 - 44 - 2 75 71 69
Mobil +380 - 97 - 8 04 03 00
ambulov@mail.ru

UNITED KINGDOM / IRELAND

EDSON MACHINERY Co. Ltd.
Unit 5, Snowhill Business Centre
Cophorne
GB - West Sussex, RH10 3EZ
Tel. +44 - 1342 - 71 97 19
Fax +44 - 1342 - 71 97 18
sales@edson.co.uk
<http://www.edson.co.uk>



DER WEG ZU UNS HOW TO REACH US

ANFAHRT

Werke Forchheim

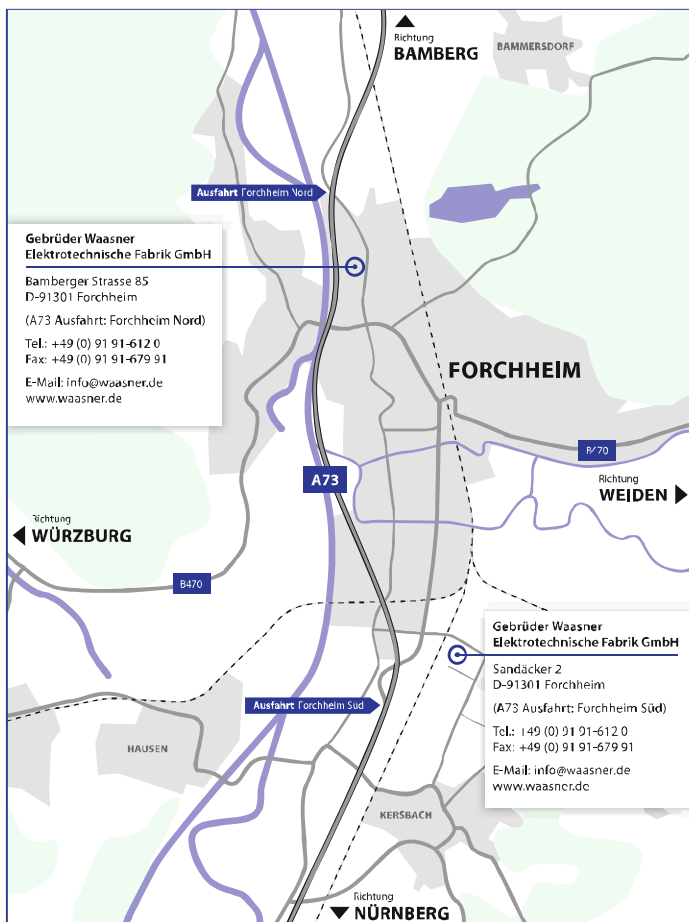

DIRECTIONS

Locations in Forchheim

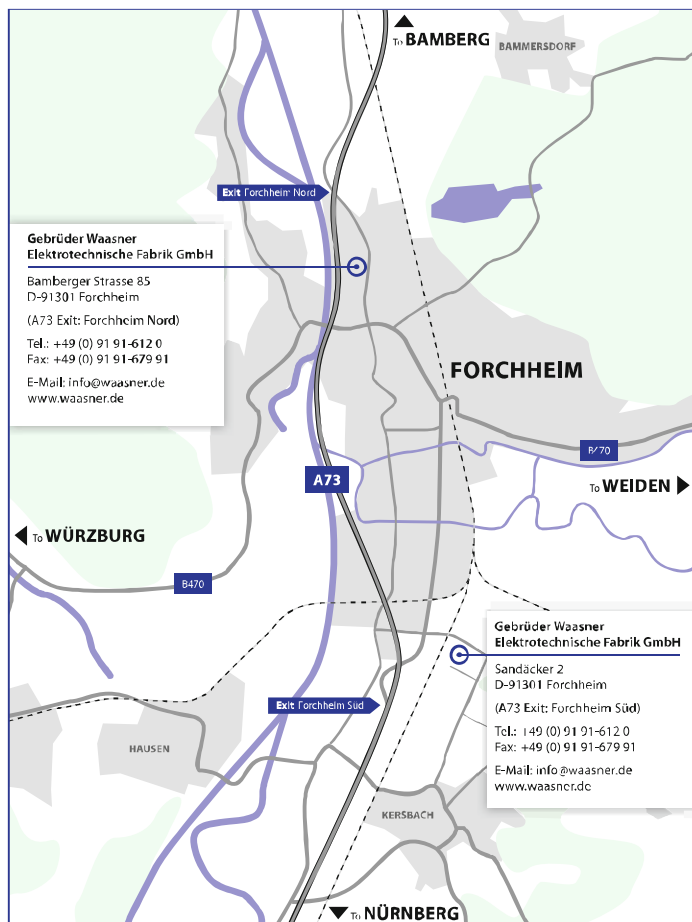

GEBRÜDER WAASNER
Elektrotechnische Fabrik GmbH

Bamberger Straße 85
D-91301 Forchheim

Tel.: +49 (0) 91 91 - 6 12-0
Fax: +49 (0) 91 91 - 6 79 91
<http://www.waasner.de>
info@waasner.de

UNSERE FERTIGUNGSMÖGLICHKEITEN - IHR VORTEIL OUR PRODUCTION TECHNOLOGIES - YOUR PROFIT



lose Bleche / single laminations



stanzpaketiert / pre-stacked



verschweißt / welded



verklebt / glued



Gebrüder Waasner
Elektrotechnische Fabrik GmbH

Bamberger Straße 85
D-91301 Forchheim

Tel. +49 (0) 91 91 - 6 12 - 0
Fax +49 (0) 91 91 - 6 79 91
<http://www.waasner.de>
info@waasner.de