

# HCD-SD1

## SERVICE MANUAL

AEP Model  
UK Model  
E Model



HCD-SD1 is the amplifier, CD and tuner section in CMT-SD1.

CD SECTION	Model Name Using Similar Mechanism	HCD-MD313
	Mechanism Type	CDM13B-5BD19
	Base Unit Type	BU-5BD19
	Optical Pick-up Type	KSS-213B/K-N

### SPECIFICATIONS

#### Amplifier section

European model:  
DIN power output (Rated)  
20 + 20 watts  
(6 ohms at 1 kHz, DIN)

Continuous RMS power output (Reference)  
25 + 25 watts  
(6 ohms at 1 kHz,  
10% THD)

Music power output (Reference)  
40 + 40 watts

Other models:  
DIN power output (Rated)  
20 + 20 watts  
(6 ohms at 1 kHz, DIN,  
240 V)  
18 + 18 watts  
(6 ohms at 1 kHz, DIN,  
220 V)

Continuous RMS power output (Reference)  
25 + 25 watts  
(6 ohms at 1 kHz,  
10% THD, 240 V)  
23 + 23 watts  
(6 ohms at 1 kHz,  
10% THD, 220 V)

Inputs  
TAPE IN: voltage  
250 mV, impedance  
47 kilohms  
AUX IN: voltage  
600 mV, impedance  
47 kilohms  
MD IN: voltage 600 mV,  
impedance 47 kilohms

#### Outputs

TAPE OUT: voltage  
250 mV, impedance  
1 kilohms  
MD OUT: voltage  
600 mV, impedance  
1 kilohms  
CD OUT: Optical  
PHONES (stereo phones  
jack): accepts headphones  
of 8 ohms or more

#### CD player section

System  
Compact disc and digital  
audio system

Laser  
Semiconductor laser  
( $\lambda=780$  nm)  
Emission duration:  
continuous

Laser output  
Max. 44.6  $\mu$ W\*  
\*This output is the value  
measured at a distance of  
200 mm from the  
objective lens surface on  
the Optical Pick-up Block  
with a 7 mm aperture.

Frequency response  
20 Hz - 20,000 kHz

— Continued on next page —

## COMPACT DISC RECEIVER

# SONY®



## Tuner section

FM stereo, FM/AM superheterodyne tuner

## FM tuner section

Tuning range 87.5 – 108.0 MHz  
(50 kHz step)  
Aerial FM lead aerial  
Aerial terminals 75 ohms unbalanced  
Intermediate frequency 10.7 MHz

## AM tuner section

Tuning range  
European model: 531 – 1,602 kHz  
(with the interval set at 9 kHz)  
Other models: 531 – 1,602 kHz  
(with the interval set at 9 kHz)  
530 – 1,710 kHz  
(with the interval set at 10 kHz)  
Aerial AM loop aerial  
External aerial terminals  
Intermediate frequency 450 kHz

## General

Power requirements  
European model: 230 V AC, 50/60 Hz  
Other models: 220 – 240 V AC, 50/60 Hz  
Power consumption 60 W (Normal)  
3 W (power off, with clock display)  
1 W (power off, without clock display)  
Dimensions 190 x 91 x 315 mm  
Mass Approx. 4.4 kg

Designs and specifications are subject to change without notice.

Laser component in this product is capable of emitting radiation exceeding the limit for Class 1.

CLASS 1 LASER PRODUCT  
LUOKAN 1 LASERLAITE  
KLASS 1 LASERAPPARAT

This appliance is classified as a CLASS 1 LASER product. The CLASS 1 LASER PRODUCT MARKING is located on the rear exterior.

**CAUTION** : INVISIBLE LASER RADIATION WHEN OPEN AND INTERLOCKS DEFEATED. AVOID EXPOSURE TO BEAM.  
**ADVARSEL** : USYNLIG LASERSTRÅLING VED ÅBNING NÅR SIKKERHEDSAFBRYDERE ER UDE AF FUNKTION. UNDGÅ UDSÆTTELSE FOR STRÅLING.  
**VORSICHT** : UNSICHTBARE LASERSTRAHLUNG. WENN ABDECKUNG, GEÖFFNET UND SICHERHEITSSPERRUNG ÜBERBRÜCKT, NICHT DEM STRAHL AUSSETZEN.  
**VARO!** : AVATTAESSA JA SUOJALUKITUS OHITETTAESSA OLET ALTIJAIN NÄKYMÄTTÖMÄLLE LASERSÄTELYLLE. ÄLÄ KATSO SÄTEESEEN.  
**WARNING** : OSYNLIG LASERSTRÅLING NÅR DENNA DEL ÅR ÖPPNAD OCH SPÅRREN ÅR URKOPPLAD, BETRÄKTA EJ STRÅLEN.  
**ADVERSEL** : USYNLIG LASERSTRÅLING NÅR DEKSEL ÅPNES OG SIKKERHEDSLÅS BRYTES. UNNGÅ EKSPONERING FOR STRÅLEN.  
**VIGVAZÁRT!** : A BURKOLAT NYITÁSAKOR LÁTHATATLAN LÉZERSUGÁRVESZÉLY! KERÜLJE A BESUGÁRZÁST!

This caution label is located inside the unit.

## CAUTION

Use of controls or adjustments or performance of procedures other than those specified herein may result in hazardous radiation exposure.

## Notes on chip component replacement

- Never reuse a disconnected chip component.
- Notice that the minus side of a tantalum capacitor may be damaged by heat.

## Flexible Circuit Board Repairing

- Keep the temperature of soldering iron around 270°C during repairing.
- Do not touch the soldering iron on the same conductor of the circuit board (within 3 times).
- Be careful not to apply force on the conductor when soldering or unsoldering.

## MODEL IDENTIFICATION

### – Specification Label –

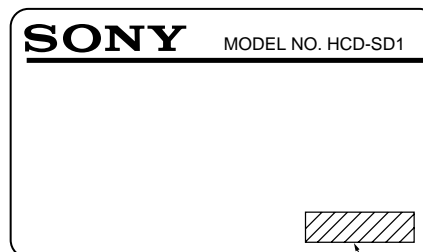

Parts No.

## SAFETY-RELATED COMPONENT WARNING !!

COMPONENTS IDENTIFIED BY MARK  $\triangle$  OR DOTTED LINE WITH MARK  $\triangle$  ON THE SCHEMATIC DIAGRAMS AND IN THE PARTS LIST ARE CRITICAL TO SAFE OPERATION. REPLACE THESE COMPONENTS WITH SONY PARTS WHOSE PART NUMBERS APPEAR AS SHOWN IN THIS MANUAL OR IN SUPPLEMENTS PUBLISHED BY SONY.

MODEL	PARTS No.
AEP, UK model	4-212-711-0□
SP, HK model	4-212-712-0□

- Abbreviation  
HK : Hong Kong model  
SP : Singapore model

## TABLE OF CONTENTS

<b>1. SERVICING NOTE</b> .....	4
<b>2. GENERAL</b> .....	7
<b>3. DISASSEMBLY</b>	
3-1. Loading Panel .....	8
3-2. Glass ASSY .....	8
3-3. Front Panel .....	9
3-4. Main Board and Tuner Unit .....	9
3-5. CD Mechanism Deck .....	10
3-6. Back Panel .....	10
3-7. Disc Table .....	11
3-8. Optical Pick-up .....	11
<b>4. SERVICE MODE</b> .....	12
<b>5. TEST MODE</b> .....	13
<b>6. ELECTRICAL ADJUSTMENTS</b> .....	14
<b>7. DIAGRAMS</b>	
7-1. Circuit Boards Location .....	16
7-2. Block Diagrams	
• BD Section .....	17
• Main Section .....	19
7-3. Schematic Diagram – BD Section – .....	23
7-4. Printed Wiring Board – BD Section – .....	25
7-5. Schematic Diagram – Main (1/2) Section – .....	27
7-6. Schematic Diagram – Main (2/2) Section – .....	29
7-7. Printed Wiring Board – Main Section – .....	31
7-8. Schematic Diagram – Sub Trans Section – .....	33
7-9. Printed Wiring Board – Sub Trans Section – .....	34
7-10. Schematic Diagram – Panel Section – .....	35
7-11. Printed Wiring Board – Panel Section – .....	37
7-12. Schematic Diagram – AMP Section – .....	39
7-13. Printed Wiring Board – AMP Section – .....	41
7-14. Schematic Diagram – Connector Section – .....	43
7-15. Printed Wiring Board – Connector Section – .....	45
7-16. Schematic Diagram – REG Section – .....	47
7-17. Printed Wiring Board – REG Section – .....	49
7-18. IC Block Diagrams .....	51
7-19. IC Pin Functions .....	54
<b>8. EXPLODED VIEWS</b>	
8-1. Front Panel Section .....	56
8-2. Chassis Section .....	57
8-3. Mechanism Deck Section (CDM13B-5BD19) .....	58
8-4. Base Unit Section (BU-5BD19).....	59
<b>9. ELECTRICAL PARTS LIST</b> .....	60

### NOTES ON HANDLING THE OPTICAL PICK-UP BLOCK OR BASE UNIT

The laser diode in the optical pick-up block may suffer electrostatic break-down because of the potential difference generated by the charged electrostatic load, etc. on clothing and the human body.

During repair, pay attention to electrostatic break-down and also use the procedure in the printed matter which is included in the repair parts.

The flexible board is easily damaged and should be handled with care.

### NOTES ON LASER DIODE EMISSION CHECK

The laser beam on this model is concentrated so as to be focused on the disc reflective surface by the objective lens in the optical pick-up block. Therefore, when checking the laser diode emission, observe from more than 30 cm away from the objective lens.

### LASER DIODE AND FOCUS SEARCH OPERATION CHECK

Carry out the “S curve check” in “CD section adjustment” and check that the S curve waveform is output two times.

## SECTION 1 SERVICING NOTE

### OPENING THE DISC TRAY WHEN POWER IS OFF

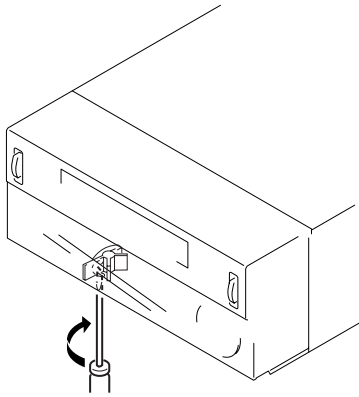

- ❶ Using a thin screwdriver, rotate the internal cam in the arrow direction completely.

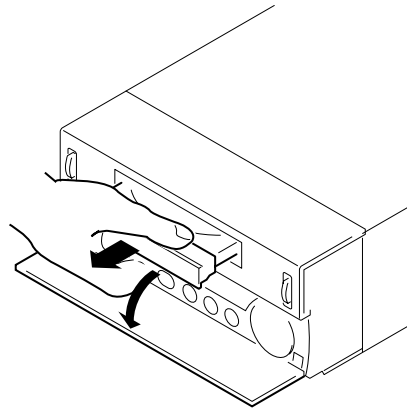

- ❷ Open the glass door, and pull out the loading panel.

### ATTACHING THE GLASS ASSEMBLY

- Attach according to steps ❶ to ❹.

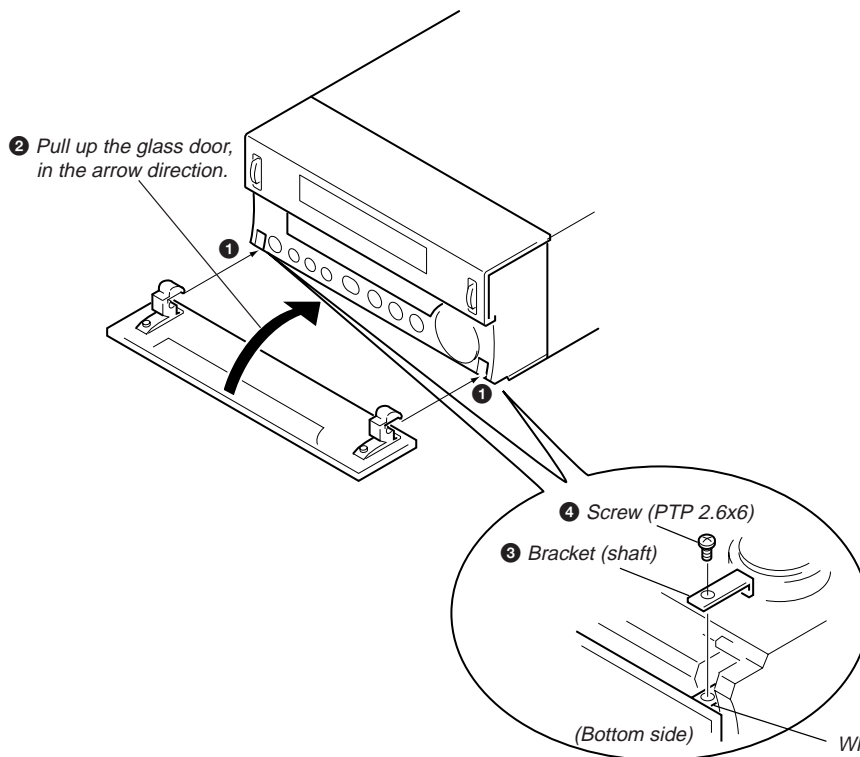

When securing this part, position at the center to allow some play. Open and close the glass window several times, and check that the parts do not touch each other.

## POSITIONS FOR SERVICING THE CONNECTOR BOARD, SUB-TRANS BOARD, CHEMI-CON BOARD, AND AMP BOARD

- ① Remove the four screws securing the upper cover, and remove the upper cover.
- ② Remove the loading panel. (Refer to SECTION 3 DISASSEMBLY.)
- ③ Remove the four screws **A** securing the MAIN board, five screws **B** securing the rear panel, two flat cables (CN701, CN702), and open the MAIN board as shown in the figure.
- ④ Remove the two screws **C** securing the heat sink, and remove the AMP board and CHEMI-CON board.
- ⑤ Remove the two screws **D** securing the SUB-TRANS board and four screws **E** securing the CONNECTOR board, and remove the SUB-TRANS board and CONNECTOR board.
- ⑥ Return the MAIN board to its original position.
- ⑦ Insulate these boards and the MAIN board with paper, etc., and assemble the CONNECTOR board, SUB-TRANS board, CHEMI-CON board, and AMP board on these boards.

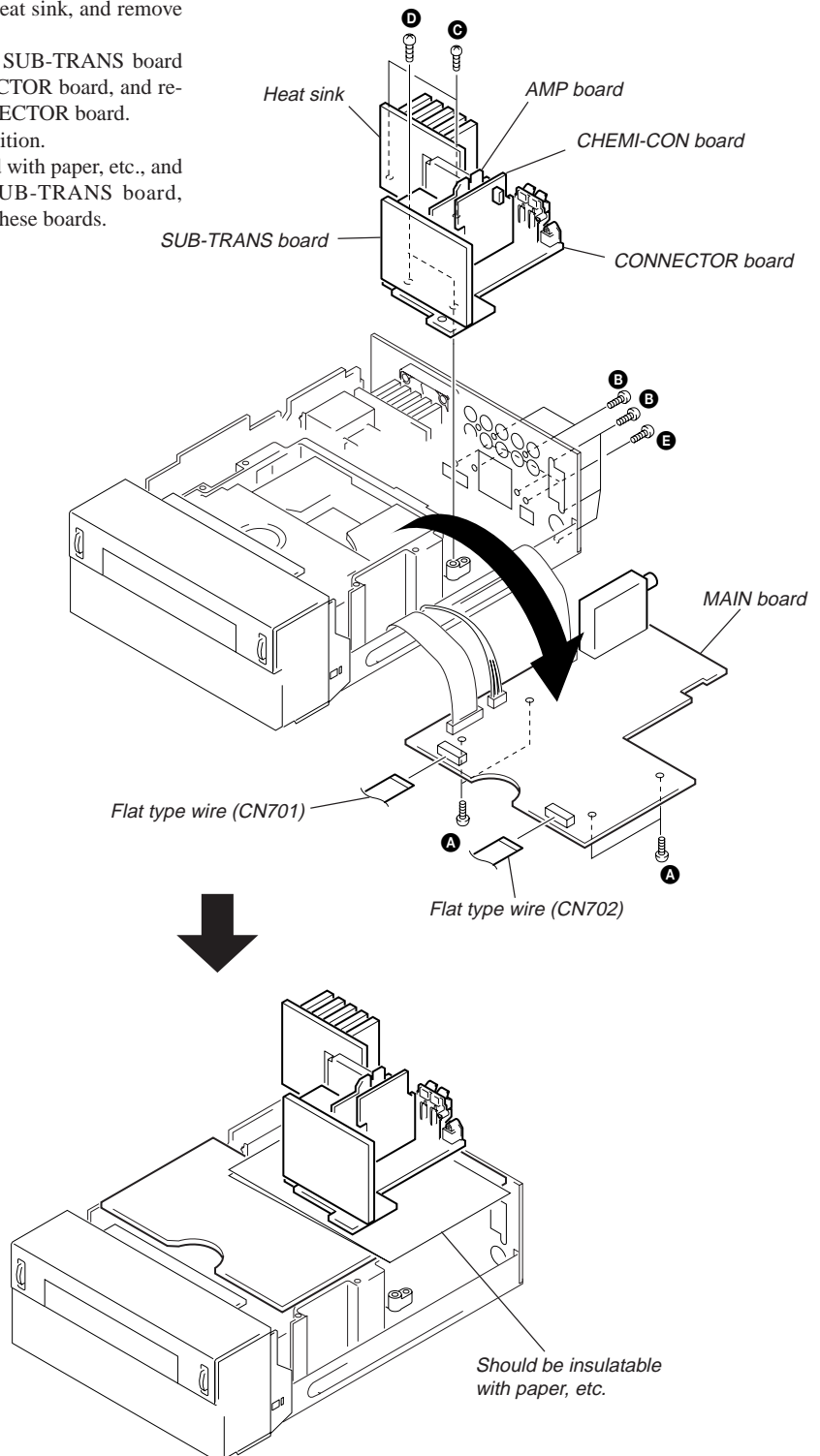

## POSITION FOR SERVICING THE CD MECHANISM DECK

- 1 Remove the four screws securing the upper cover, and remove the upper cover.
- 2 Remove the loading panel. (Refer to SECTION 3 DISASSEMBLY.)
- 3 Remove the four screws **A** securing the MAIN board, five screws **B** of the rear panel, and flat cables (CN701, CN702), and remove the MAIN board.
- 4 Remove the two screws **D** securing the SUB-TRANS board, and remove the SUB-TRANS board.
- 5 Remove the two screws **F** securing the REG board.
- 6 Remove the three screws **G** securing the CDM cover, and remove the CDM cover.
- 7 Remove the two screws **H** securing the CDM, move the CDM backwards by about 5 mm horizontally, and then lift upwards.
- 8 Rotate the CDM in the counterclockwise direction by about 30° to remove.
- 9 Return the MAIN and SUB-TRANS boards to their original positions.

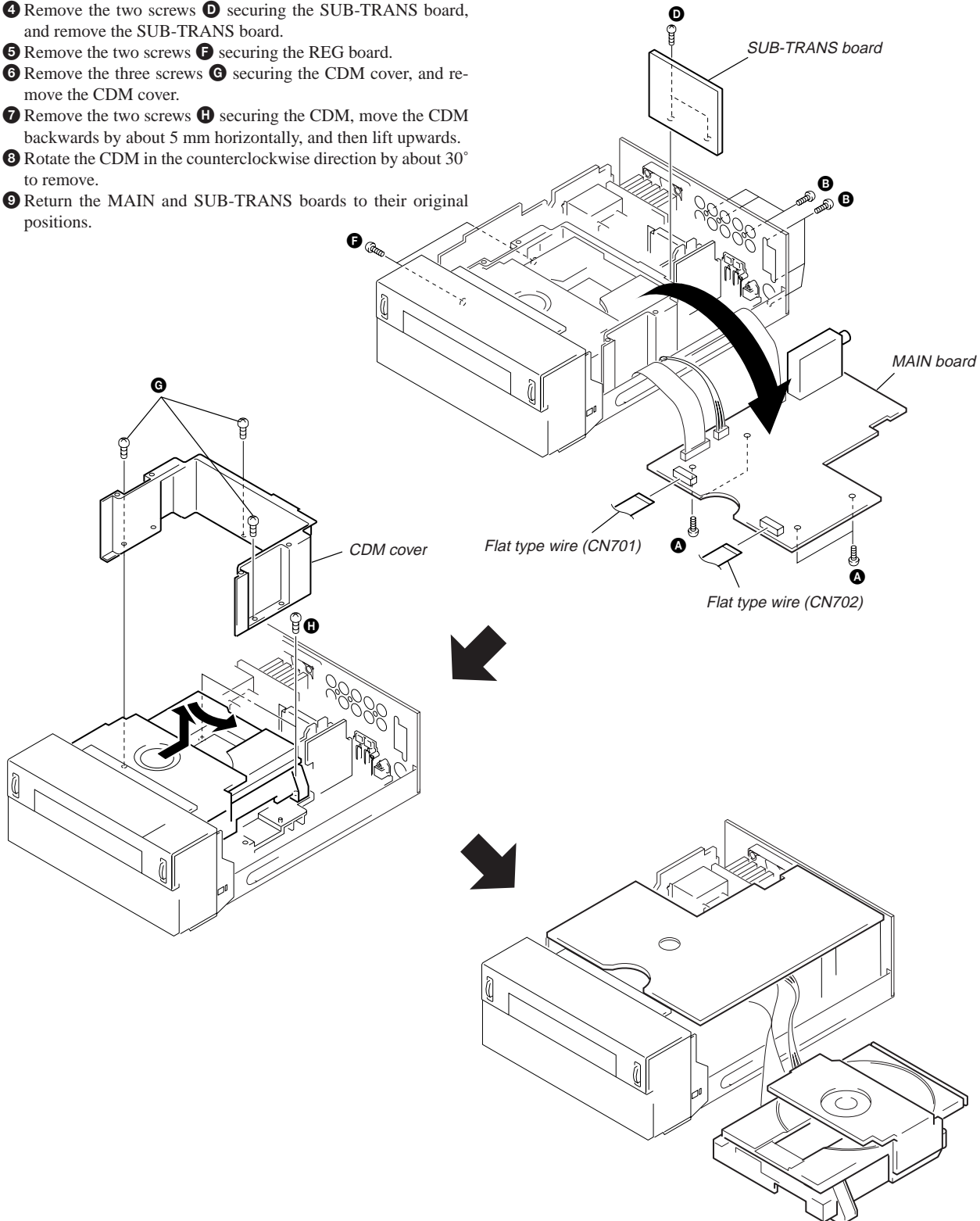

## SECTION 2 GENERAL

Front Panel

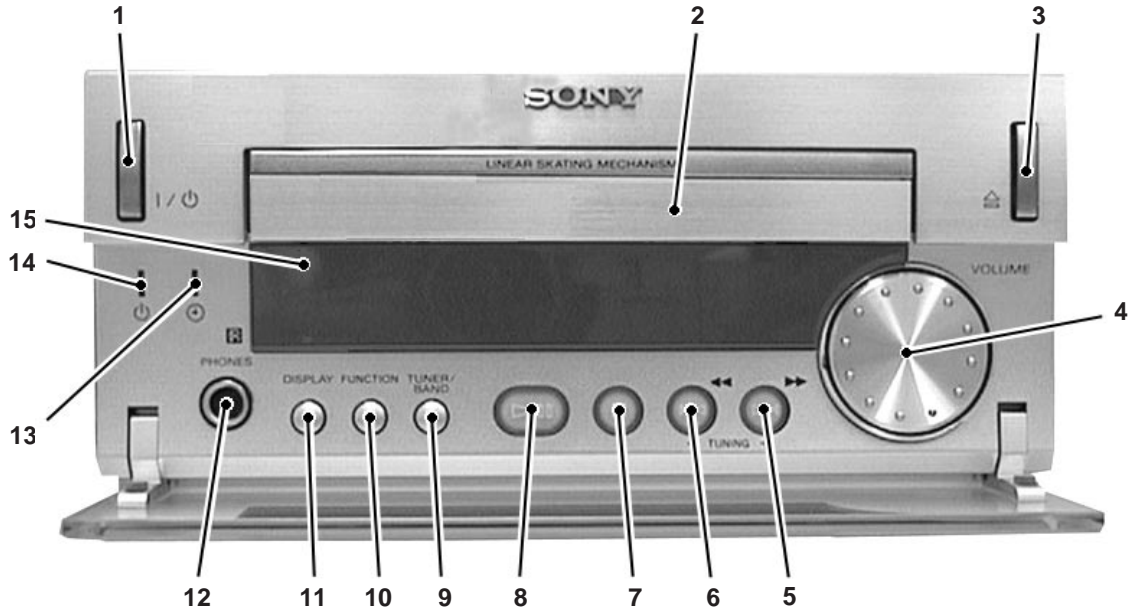

### Location of Parts and Controls

- |                            |                       |                   |
|----------------------------|-----------------------|-------------------|
| 1 I/⏻ (Power) button       | 6 ⏪/⏩/TUNING - button | 11 DISPLAY button |
| 2 CD disc tray             | 7 □ button            | 12 PHONES jack    |
| 3 ⏮ button                 | 8 ▽ button            | 13 ⏻ indicator    |
| 4 VOLUME dial              | 9 TUNER/BAND button   | 14 ⏻ indicator    |
| 5 ▹/▸/▶/▶+/TUNING + button | 10 FUNCTION button    | 15 Display window |

This section is extracted from instruction manual.

### Step 2: Setting the time

You must set the time before you can use the timer functions. The clock is on a 24-hour system for the European model, and a 12-hour system for other models. The 24-hour system model is used for illustration purpose. Set the time before turning the power on.

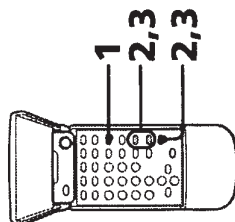

**1** Press **TIMER SET** while the power is off. The hour indication flashes.

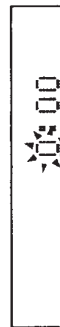

**2** Press **+/-** to set the hour then press **ENTER**. The minute indication flashes.

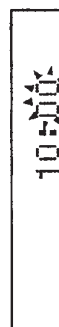

**3** Press **+/-** to set the minute then press **ENTER**. The clock starts.

## SECTION 3 DISASSEMBLY

**Note:** Follow the disassembly procedure in the numerical order given.

### 3-1. LOADING PANEL

- 1 Turn ON the power, and press the EJECT button to open the tray.
  - 2 Remove the loading panel in the arrow direction.
  - 3 Press the EJECT button to close the tray.
- If the power cannot be turned ON, refer to “Opening the Disc Tray When the Power is OFF” of “Service Note”, and open the tray.

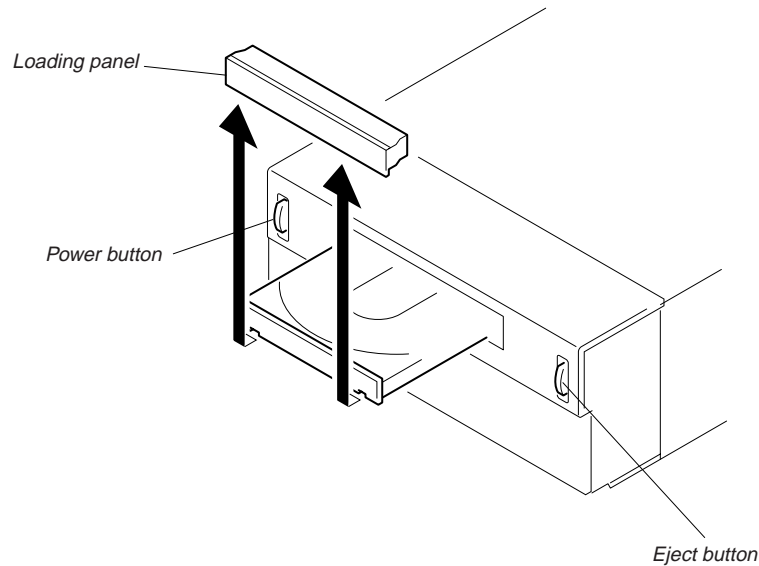

### 3-2. GLASS ASSY

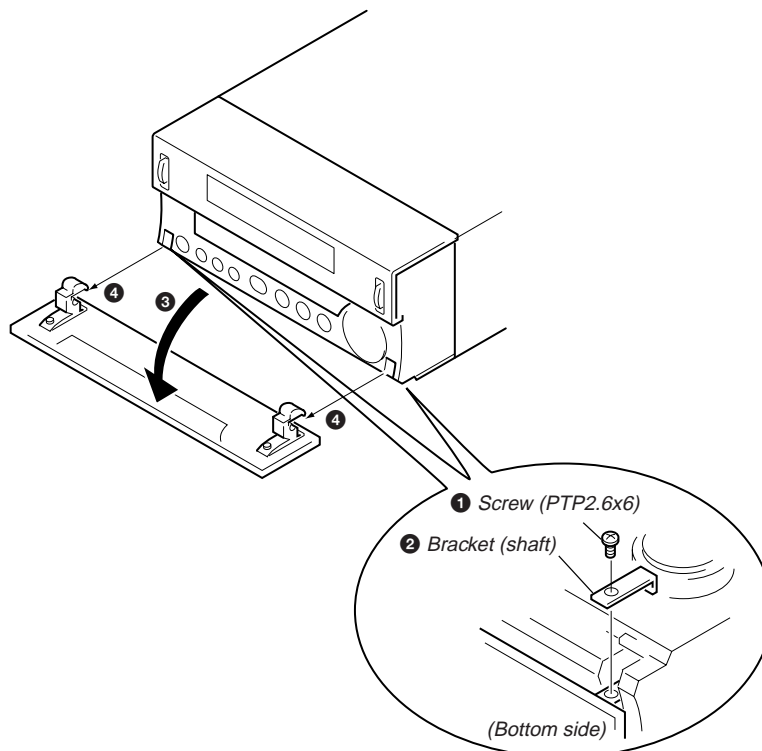



### 3-3. FRONT PANEL

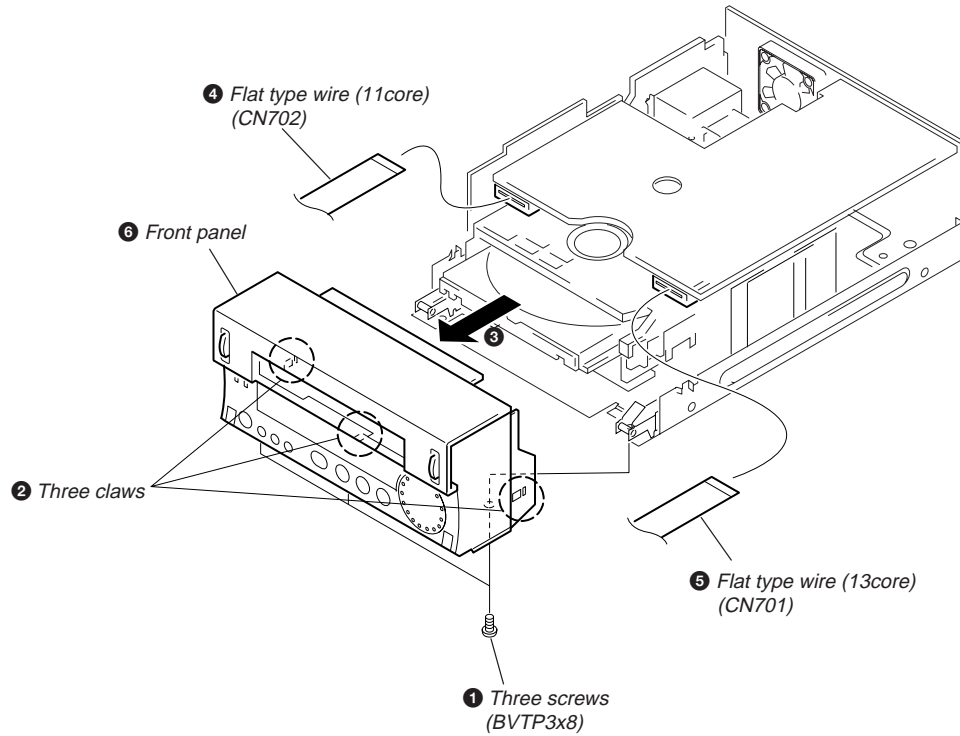

### 3-4. MAIN BOARD AND TUNER UNIT

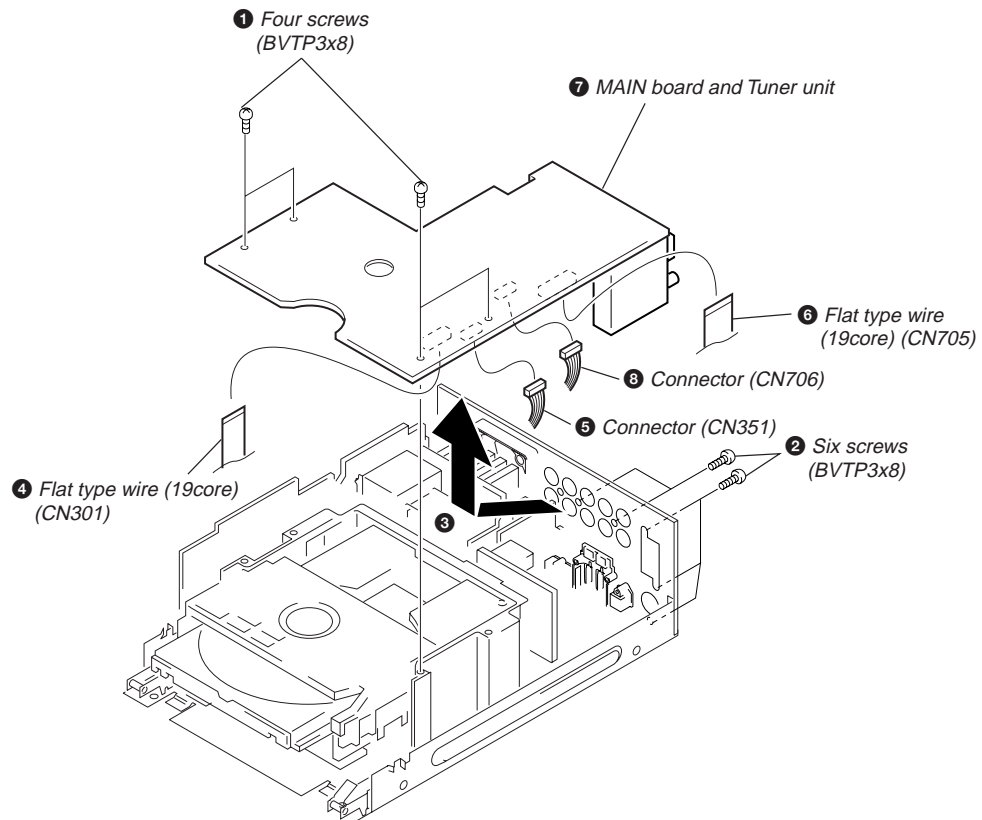

### 3-5. CD MECHANISM DECK

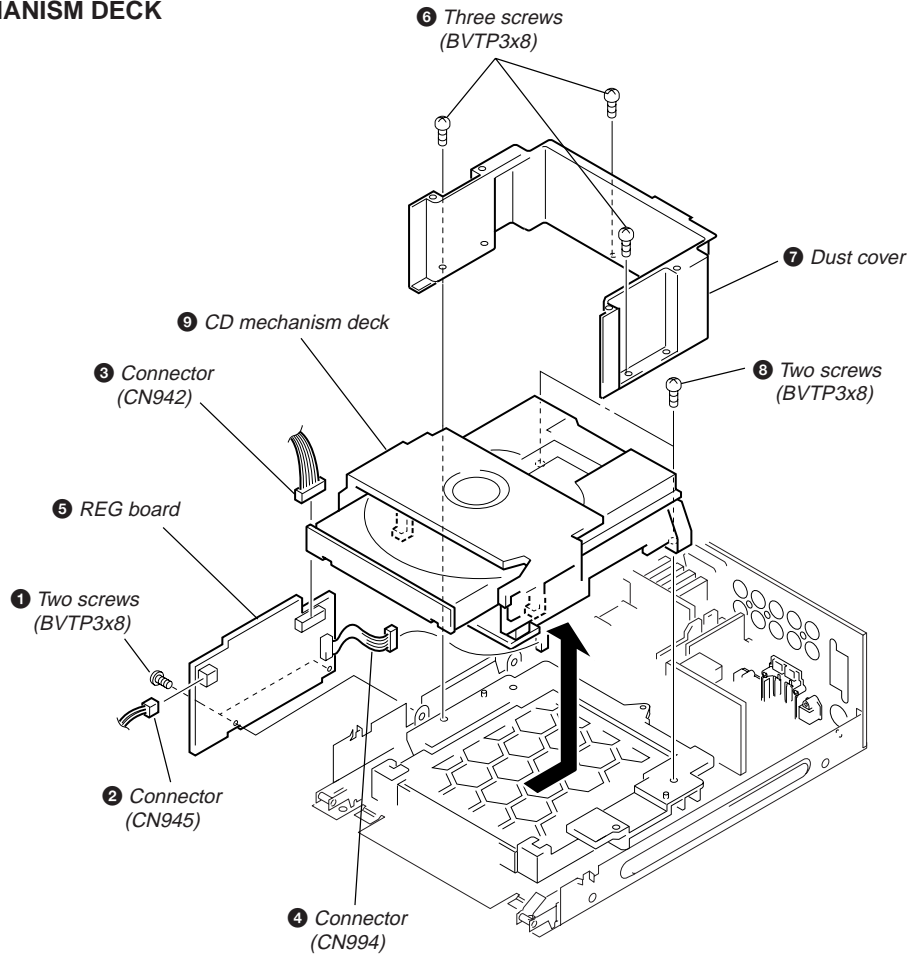

### 3-6. BACK PANEL

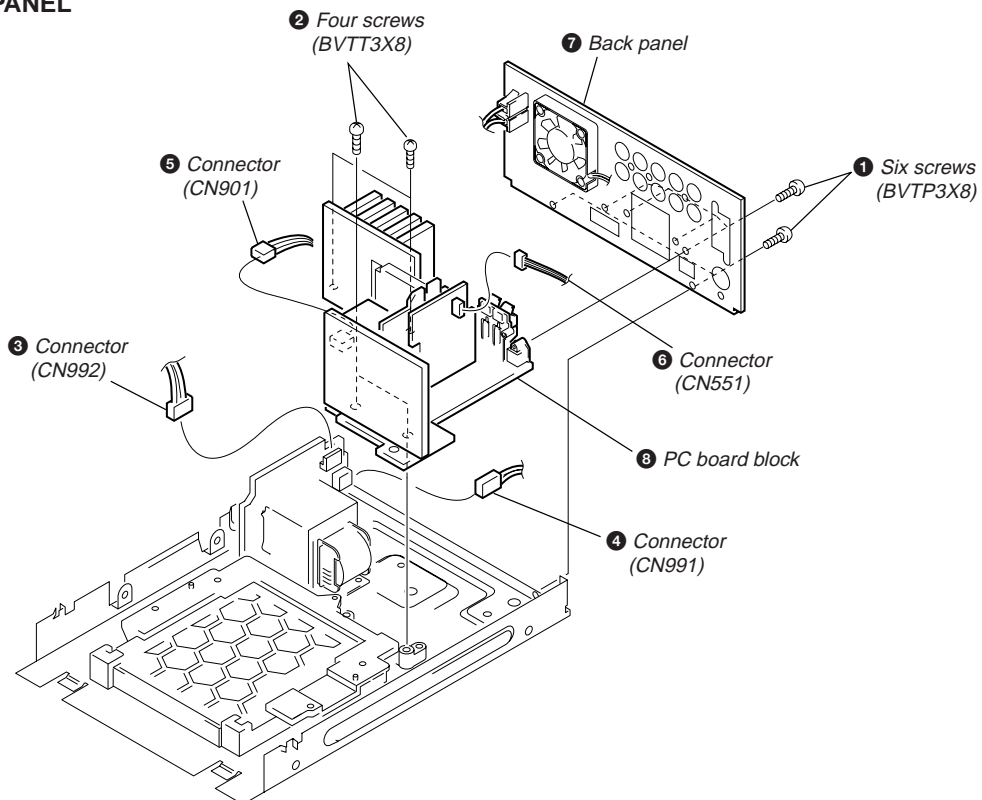

### 3-7. DISC TABLE

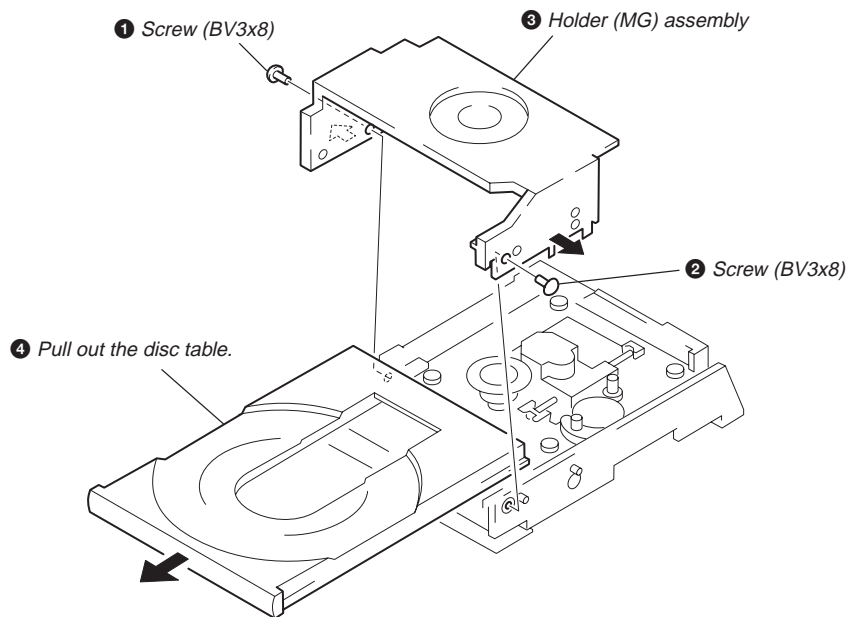

### 3-8. OPTICAL PICK-UP

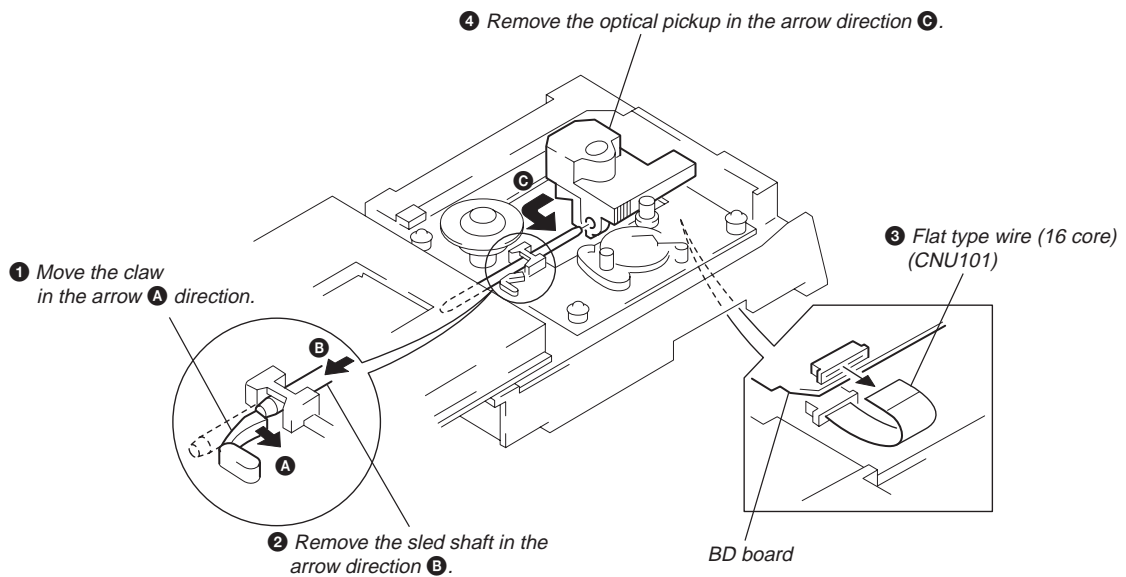









## SECTION 4 SERVICE MODE

### Key Check Mode for Complete Lighting of LED/Fluorescent Display Tube

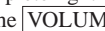
- Perform this mode to analyze and check malfunctions such as display defects and when buttons do not work.



#### Procedure:

1. Press the  button to turn on the power.
2. Press the  button and  button together.
3. All LEDs and the fluorescent display tube will light up completely.
4. Pressing the  button here will light the fluorescent display tube in the following order; Partial lighting 1 → Partial lighting 2 → Complete lighting → Partial lighting 1.....  
Turning the  dial will switch the lighting order of the LED.  
To end without shifting to the key check mode, press the  button to end.
5. Pressing the  button sets the key check mode.
6. During the key check mode, "KEY=0 JOG=0" will be displayed on the fluorescent display tube.  
Pressing a button will increase the value of "KEY=". However the value will not increase for buttons which have already been pressed once.  
Rotating the  knob in the clockwise direction increases the value of "JOG=" in the order of 1, 2, 3.... and rotating in the counterclockwise direction decreases in order of 10, 9, and 8.
7. To end the check mode, press all buttons (8 buttons). "KEY-OK" will be displayed.  
Then press any button, and disconnect the power cord from the outlet.

### Checking the Sub-Clock

- Perform this mode to check clock operations.







#### Procedure:

1. Connect an oscilloscope and frequency counter between the pin (TP791) and ground of IC701 of the MAIN board.
2. Press the  and  buttons together to display "91P = 32.768k" on the fluorescent display tube.
3. Check that the signal on the oscilloscope becomes a 32 kHz rectangular waveform and the reading of the frequency counter becomes 32.768 kHz.
4. Press the  button to end.

### Sled Servo Mode

- In this mode, the CD sled motor can be operated freely.  
Execute it when cleaning the pick-up.  
Round holes can be seen on the topmost board when the case is opened. Move the pick-up and clean off the dirt in these round holes using a cotton swab.

#### Procedure:

1. Press the  and  buttons with the power of the unit OFF.
2. When the sled servo is set, "MANUAL" is displayed on the fluorescent display tube.
3. Pressing the /TUNING/▶▶▶ button when the CD is in the stop state moves the pick-up to the outer track. Pressing the /TUNING/◀◀◀ button moves it to the inner track.
4. To end this mode, perform the following steps.
  - 1) Move the If not, the disc cannot be removed.
  - 2) Press the  and  buttons together.

#### Note:

- When ending this mode, be sure to move the pick-up to the innermost circumference. If not, the disc cannot be removed.
- Do not move the sled motor more than required as this will damage the gears.

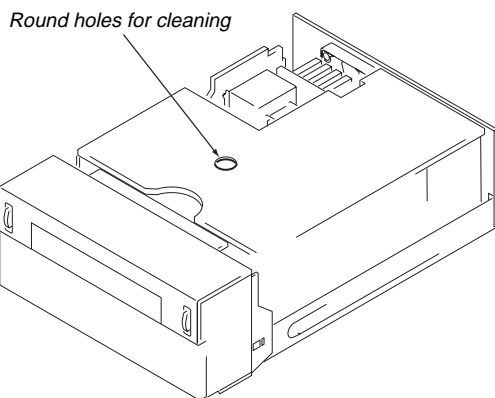

### Initializing (Forced Reset)

- Perform this mode when resetting the unit or when returning the unit to the customer.
- The preset frequency of the tuner, etc. will be the settings at shipment.

#### Procedure:

While pressing the  button, insert the power cord into the outlet.

## SECTION 5 TEST MODE

### AGING MODE

This unit is equipped with an aging mode.

Use this mode for analyzing defects and for checks after completing repairs.

After repairs, perform aging 100 times and check that the unit is normal.

The aging mode is executed in the following sequence.

The aging mode will continue as long as the unit is normal.

If the unit becomes abnormal, it will display the state and number of cycles, and operations will stop. (Refer to Table 1.)

#### Sequence of Aging Mode:

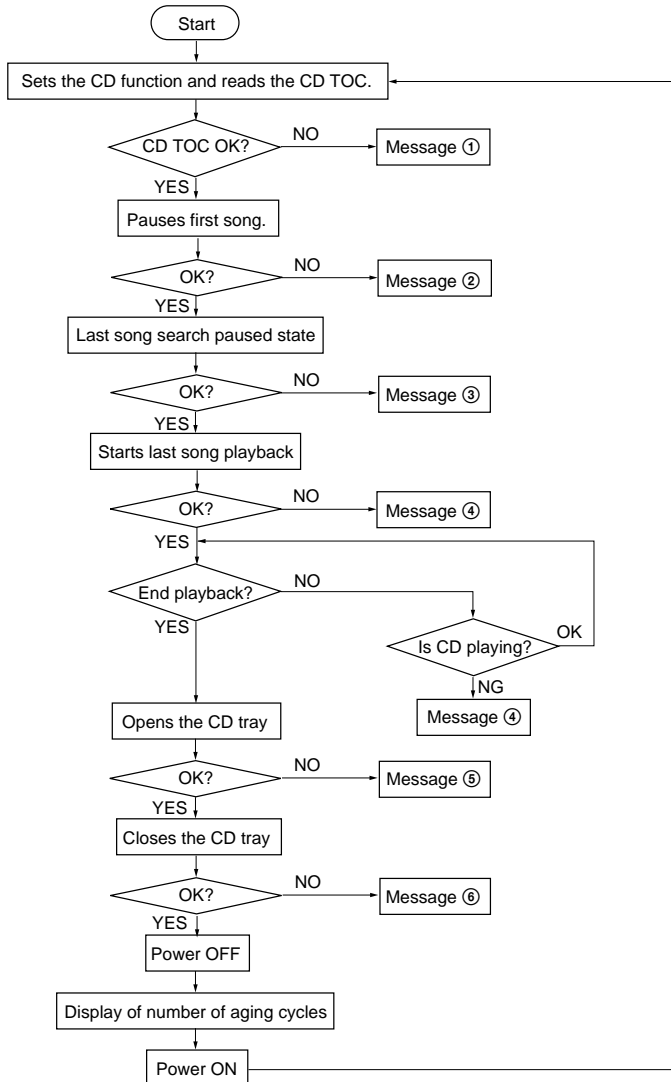

#### Procedure:

1. Press the **DISPLAY** button and **◀◀/TUNING/▶▶** button together.
2. To end aging, press the **⏻** button and end.

Table-1 Messages and Main Reasons for Stop of Aging

No	Error Messages	Details of Error	Main Causes
①	CD No Disc NG	Cannot read CD TOC.	Optical defect, spindle defect (including motor), cannot read Q data, disc defect (scratches, etc.), bad focus, bad GFS, etc.
②	CD Pause NG	Cannot set CD pause in CD synchro mode.	Disc defect (scratches, etc.), cannot read Q data, etc.
③	CD Search NG	Cannot search last track on CD.	Optical defect, sled, tracking defect (including motor), cannot read Q data, disc defect (scratches, etc.).
④	CD Play NG	Cannot play last track on CD.	Optical defect, cannot read Q data, disc defect (scratches, etc.), etc.
⑤	CD Open NG	Cannot open CD tray.	LOAD OUT SW defect
⑥	CD Close NG	Cannot close CD tray.	LOAD IN SW defect

## SECTION 6 ELECTRICAL ADJUSTMENTS

### CD SECTION

#### Note:

1. CD Block is basically designed to operate without adjustment. Therefore, check each item in order given.
2. Use YEDS-18 disc (3-702-101-01) unless otherwise indicated.
3. Use an oscilloscope with more than  $10M\Omega$  impedance.
4. Clean the object lens by an applicator with lens cleaning liquid when the signal level is low than specified value with the following checks.
5. Adjust the focus bias adjustment when optical block is replaced.

#### Focus Bias Adjustment

Perform this adjustment when the optical pick-up has been replaced or repaired.

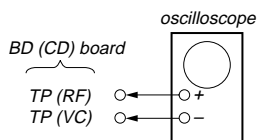

#### Procedure:

1. Connect oscilloscope to test point TP (RF).
2. Turned Power switch on.
3. Put disc (YEDS-18) in and playback.
4. Adjust RV101 so that the waveform is clear. (Clear RF signal waveform means that the shape "∩" can be clearly distinguished at the center of the waveform.)
5. After adjustment, check the RF signal level.

- RF signal  
VOLT/DIV: 200 mV  
TIME/DIV: 500 nS

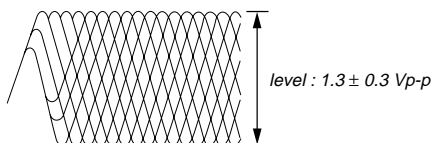

#### S Curve Check

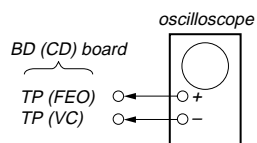

#### Procedure :

1. Connect oscilloscope to test point TP (FEO).
2. Connect between test point TP (FOK) and Ground by lead wire.
3. Turn Power switch on.
4. Put disc (YEDS-18) in and turned Power switch on again and actuate the focus search. (actuate the focus search when disc table is moving in and out.)
5. Check the oscilloscope waveform (S-curve) is symmetrical between A and B. And confirm peak to peak level within  $2.4 \pm 0.7 V_{p-p}$ .

S-curve waveform

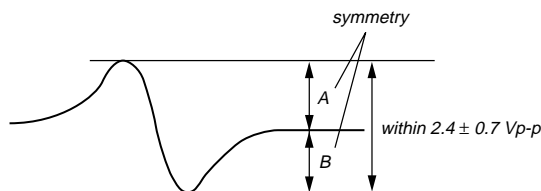

6. After check, remove the lead wire connected in step 2.

- Note:**
- Try to measure several times to make sure than the ratio of A : B or B : A is more than 10 : 7.
  - Take sweep time as long as possible and light up the brightness to obtain best waveform.

#### RF Level Check

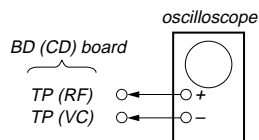

#### Procedure :

1. Connect oscilloscope to test point TP (RF) on BD board.
2. Turned Power switch on.
3. Put disc (YEDS-18) in and playback.
4. Confirm that oscilloscope waveform is clear and check RF signal level is correct or not.

**Note:** Clear RF signal waveform means that the shape "∩" can be clearly distinguished at the center of the waveform.

- RF signal  
VOLT/DIV: 200 mV  
TIME/DIV: 500 nS

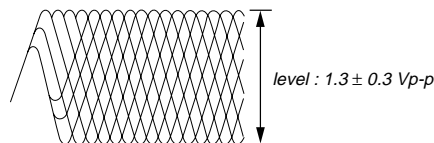

**E-F Balance (1 Track Jump) Check  
(Without remote commander)**

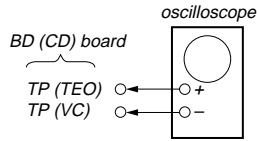

**Procedure :**

1. Connect oscilloscope to test point TP (TEO) on BD board.
2. Turn Power switch on.
3. Put disc (YEDS-18) in to play the number five track.
4. Press the "■ (Pause)" button. (Becomes the 1 track jump mode)
5. Confirm that the oscilloscope waveform is symmetrical on the top and bottom in relation to 0Vdc, and check this level.

1 track jump waveform

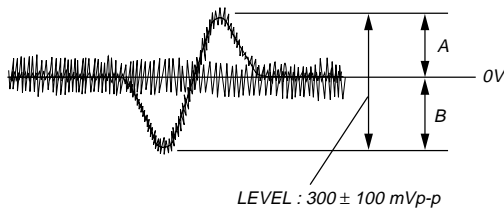

Specified level: •  $\frac{A - B}{2 (A + B)} \times 100 = \text{less than } \pm 7\%$

•  $A + B = 300 \pm 100 \text{ mVp-p}$

**Focus/Tracking Gain Adjustment (RV102, RV103)**

This gain has a margin, so even if it is slightly off.  
There is no problem.  
Therefore, do not perform this adjustment.  
Please note that it should be fixed to mechanical center position when you moved and do not know original position.

**Adjustment Location:**

**[BD (CD) BOARD] — Component Side —**

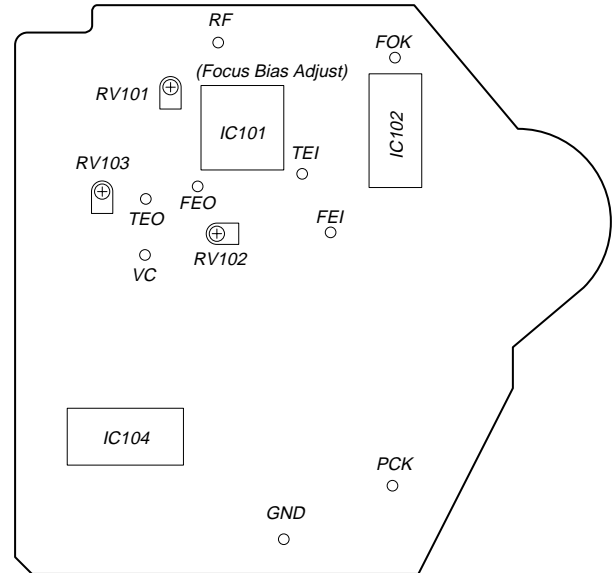

# SECTION 7 DIAGRAMS

## 7-1. CIRCUIT BOARDS LOCATION

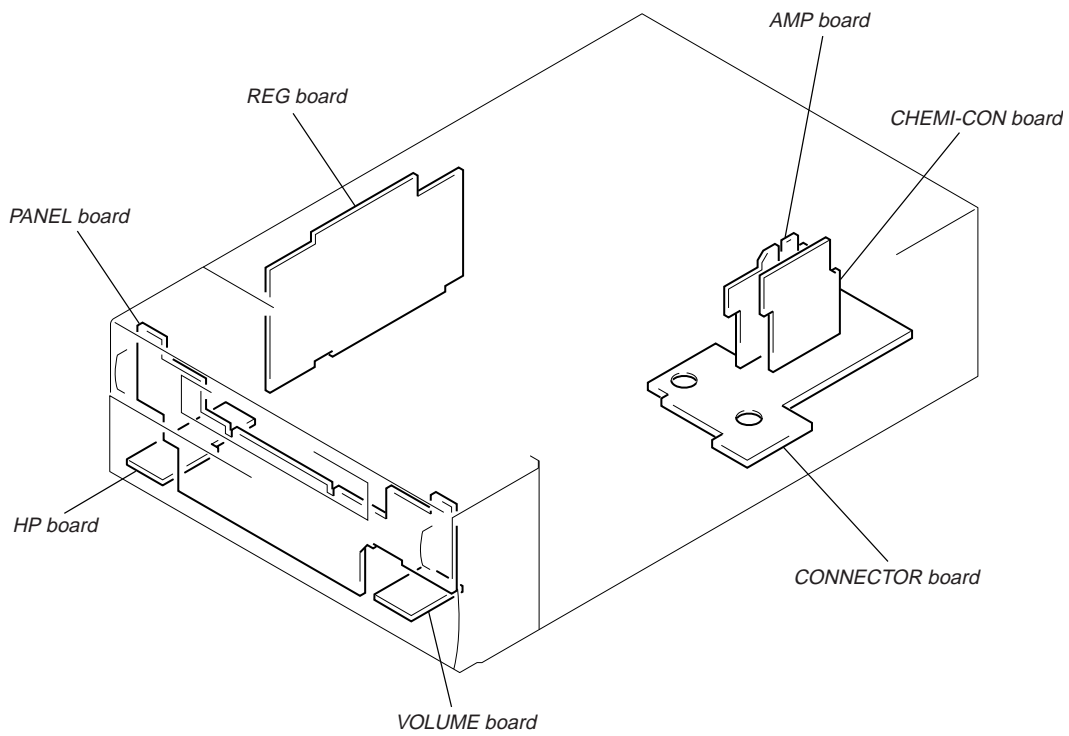
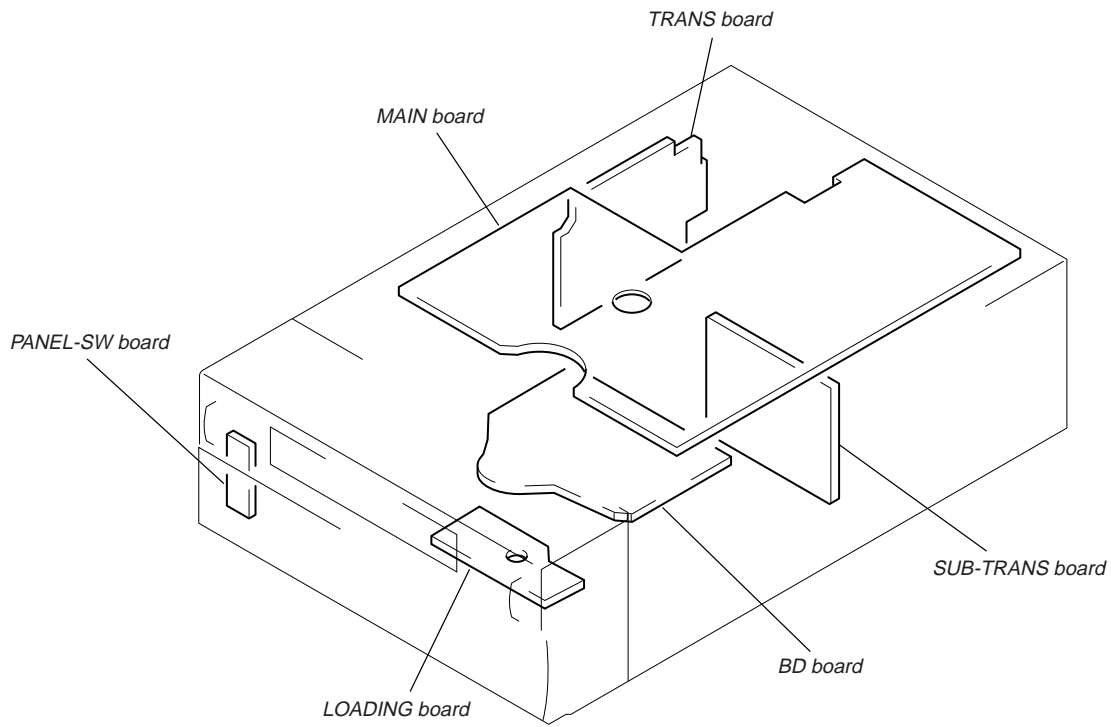



7-2. BLOCK DIAGRAMS  
- BD SECTION -

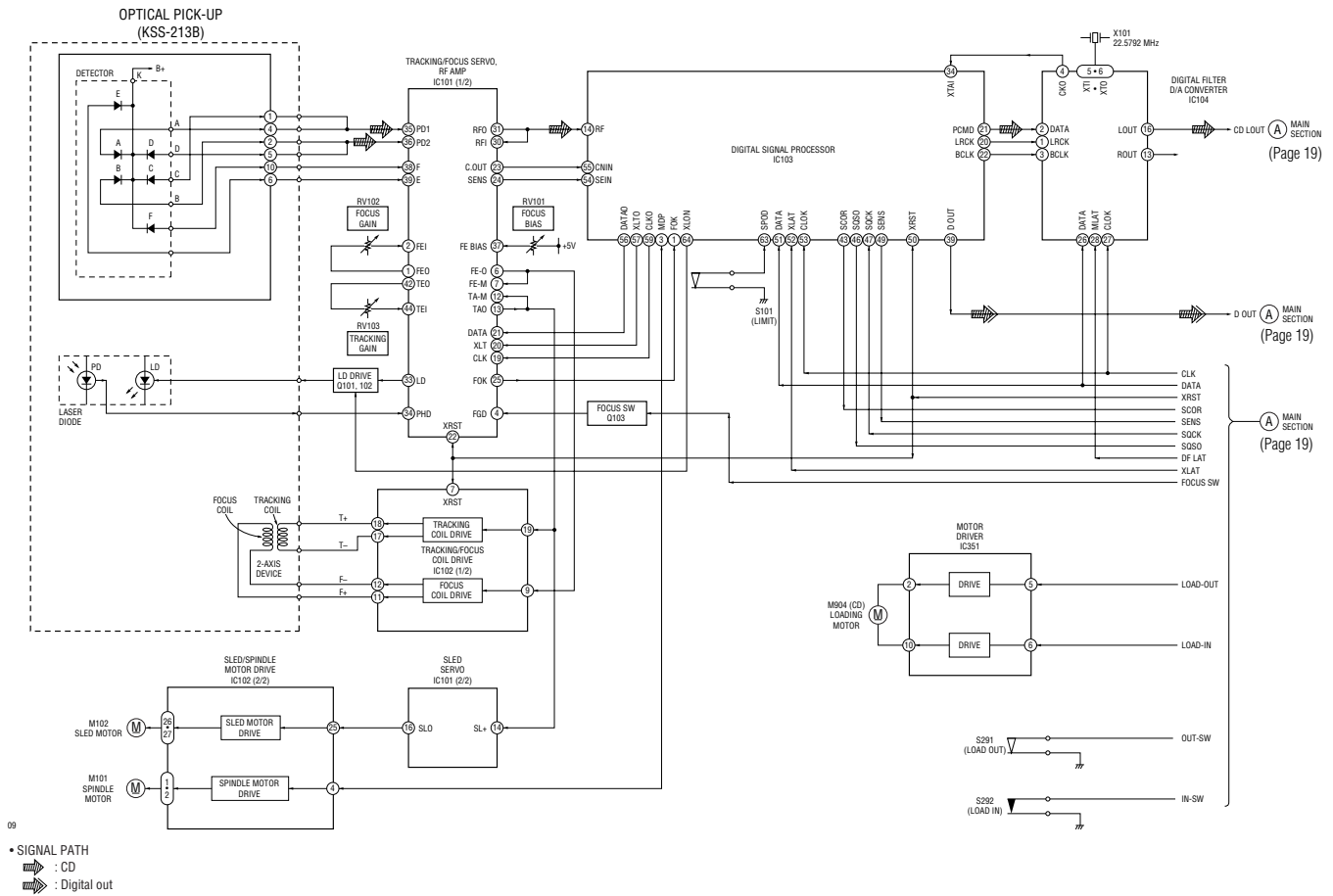

HCD-SD1

- MAIN SECTION -

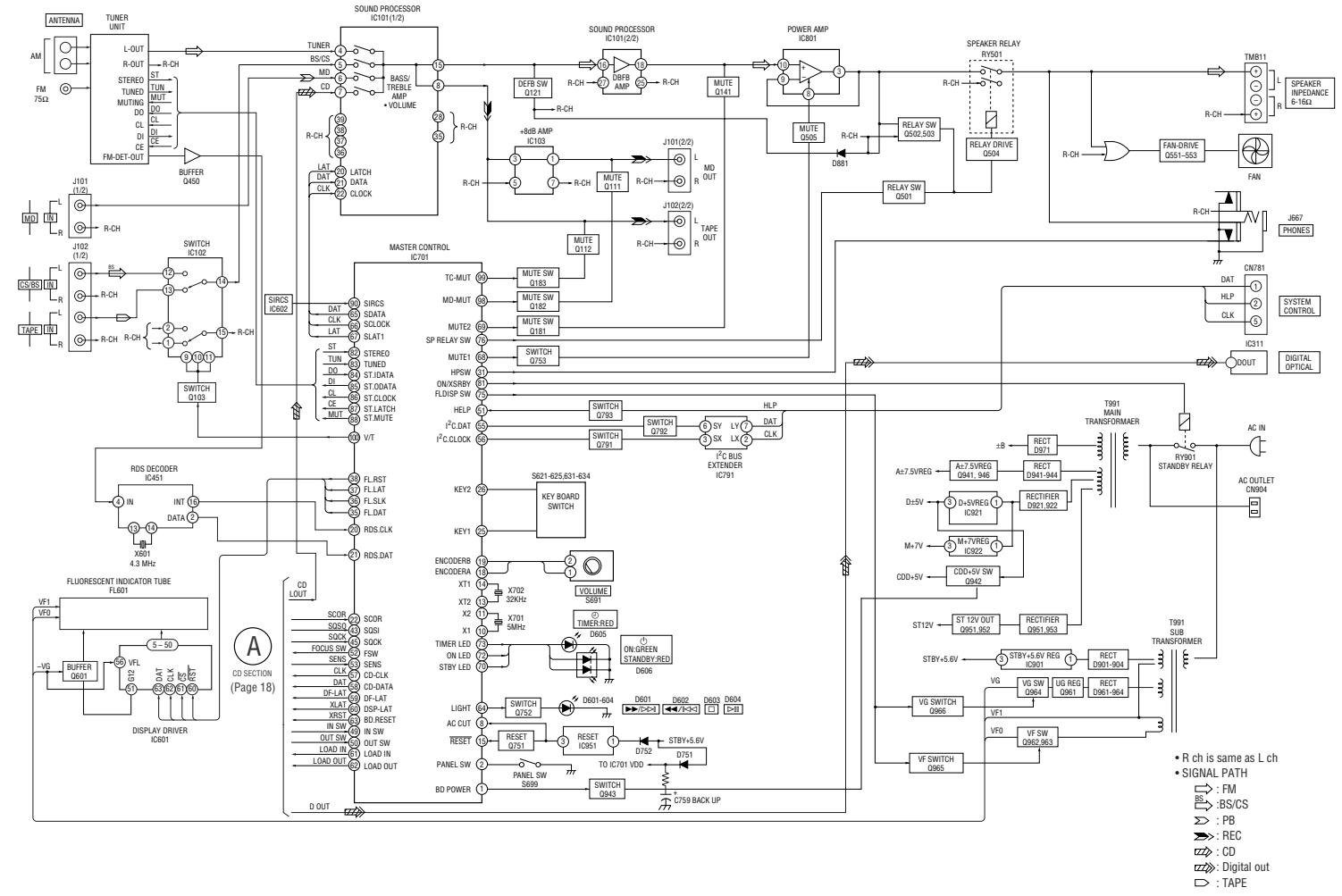

**THIS NOTE IS COMMON FOR PRINTED WIRING BOARDS AND SCHEMATIC DIAGRAMS.**  
**(In addition to this, the necessary note is printed in each block.)**

**For schematic diagrams.**

**Note:**

- All capacitors are in  $\mu\text{F}$  unless otherwise noted. pF:  $\mu\mu\text{F}$   
50 WV or less are not indicated except for electrolytics and tantalums.
- All resistors are in  $\Omega$  and  $\frac{1}{4}W$  or less unless otherwise specified.
- $\triangle$  : internal component.
- 2 : nonflammable resistor.
- 1 : fusible resistor.
- C : panel designation.

**Note:** The components identified by mark  $\triangle$  or dotted line with mark  $\triangle$  are critical for safety.  
 Replace only with part number specified.

- S : B+ Line.
- T : B- Line.
- H : adjustment for repair.
- Voltages and waveforms are dc with respect to ground in service mode.
- Voltages are taken with a VOM (Input impedance 10 M $\Omega$ ). Voltage variations may be noted due to normal production tolerances.
- Waveforms are taken with an oscilloscope. Voltage variations may be noted due to normal production tolerances.
- Circled numbers refer to waveforms.

**Signal path.**

- F : FM
- E : PB (MD)
- m : PB (TAPE)
- n : REC
- J : CD
- c : digital out
- Abbreviation
- SP : Singapore model.
- HK : Hong Kong model.

**For printed wiring boards.**

**Note:**

- X : parts extracted from the component side
- $\blacksquare$  : parts mounted on the conductor side.
- $\circ$  : Through hole.
- $\triangle$  : internal component.
- b : Pattern from the side which enables seeing.

(The other layers' patterns are not indicated.)

**Caution:**  
 Pattern face side: Parts on the pattern face side seen from the (Side B) pattern face are indicated.  
 Parts face side: Parts on the parts face side seen from the (Side A) parts face are indicated.

**• Indication of transistor**

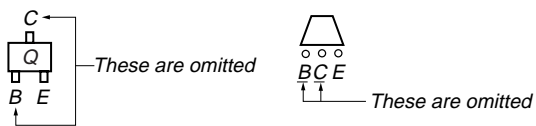

**WAVEFORMS  
- BD SECTION -**

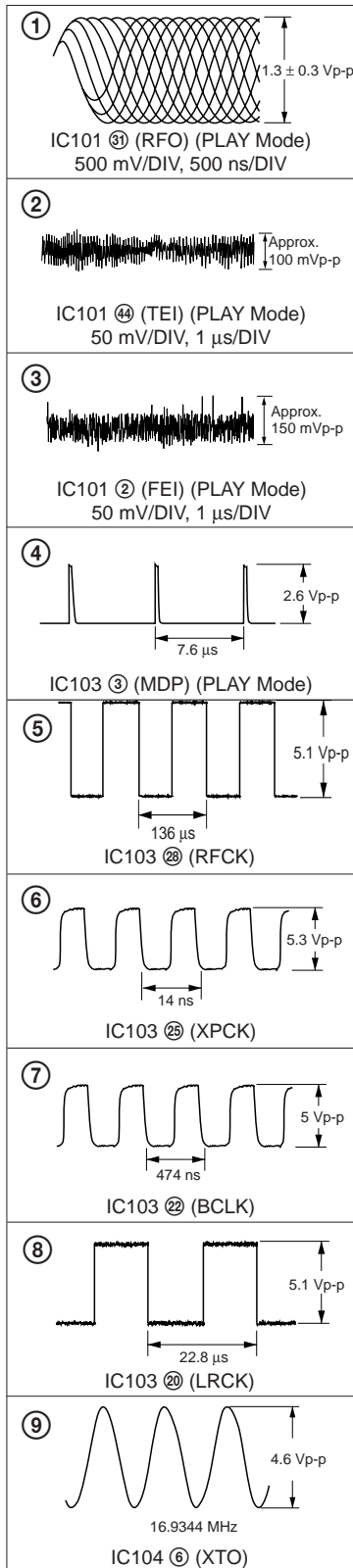

**- MAIN SECTION -**

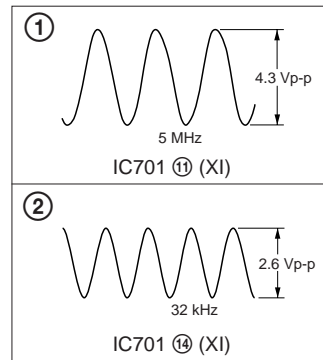

7-3. SCHEMATIC DIAGRAM - BD SECTION -  
• See page 22 for Waveforms.  
• See page 51 for IC Block Diagrams.

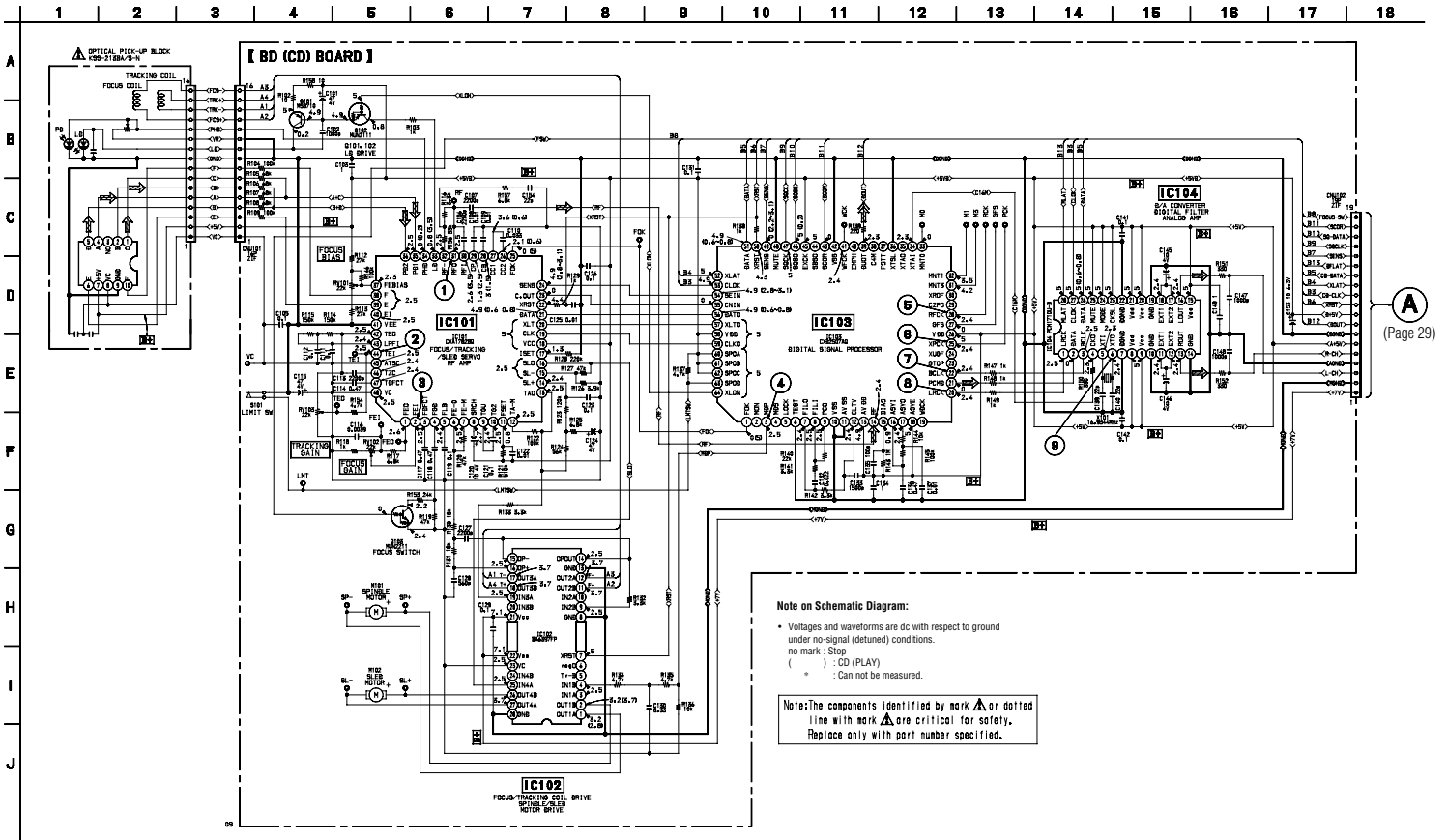

7-4. PRINTED WIRING BOARD – BD SECTION –  
 • See page 16 for Circuit Boards Location.

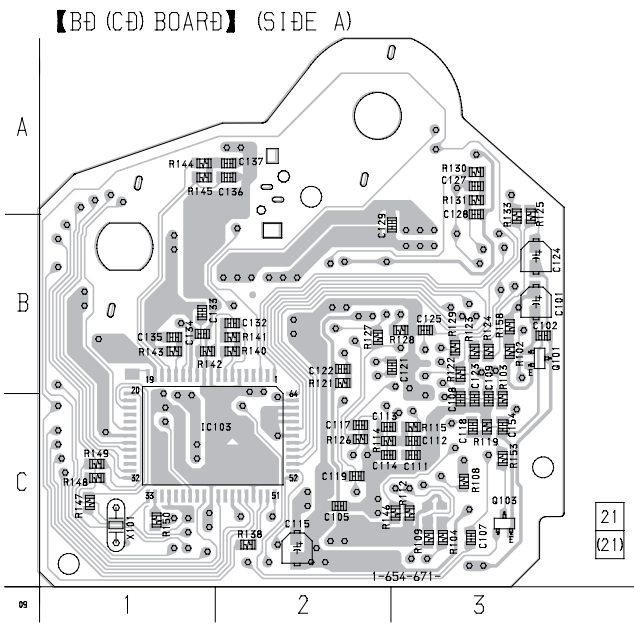

• Semiconductor Location

Ref. No.	Location
IC103	C-1
Q101	B-3
Q103	C-3



• Semiconductor Location

Ref. No.	Location
IC101	B-1
IC102	B-1
IC104	C-3
Q102	B-1

HCD-SD1

7-5. SCHEMATIC DIAGRAM – MAIN (1/2) SECTION –

- See page 22 for Waveforms.
- See page 31 for Printed Wiring Board.

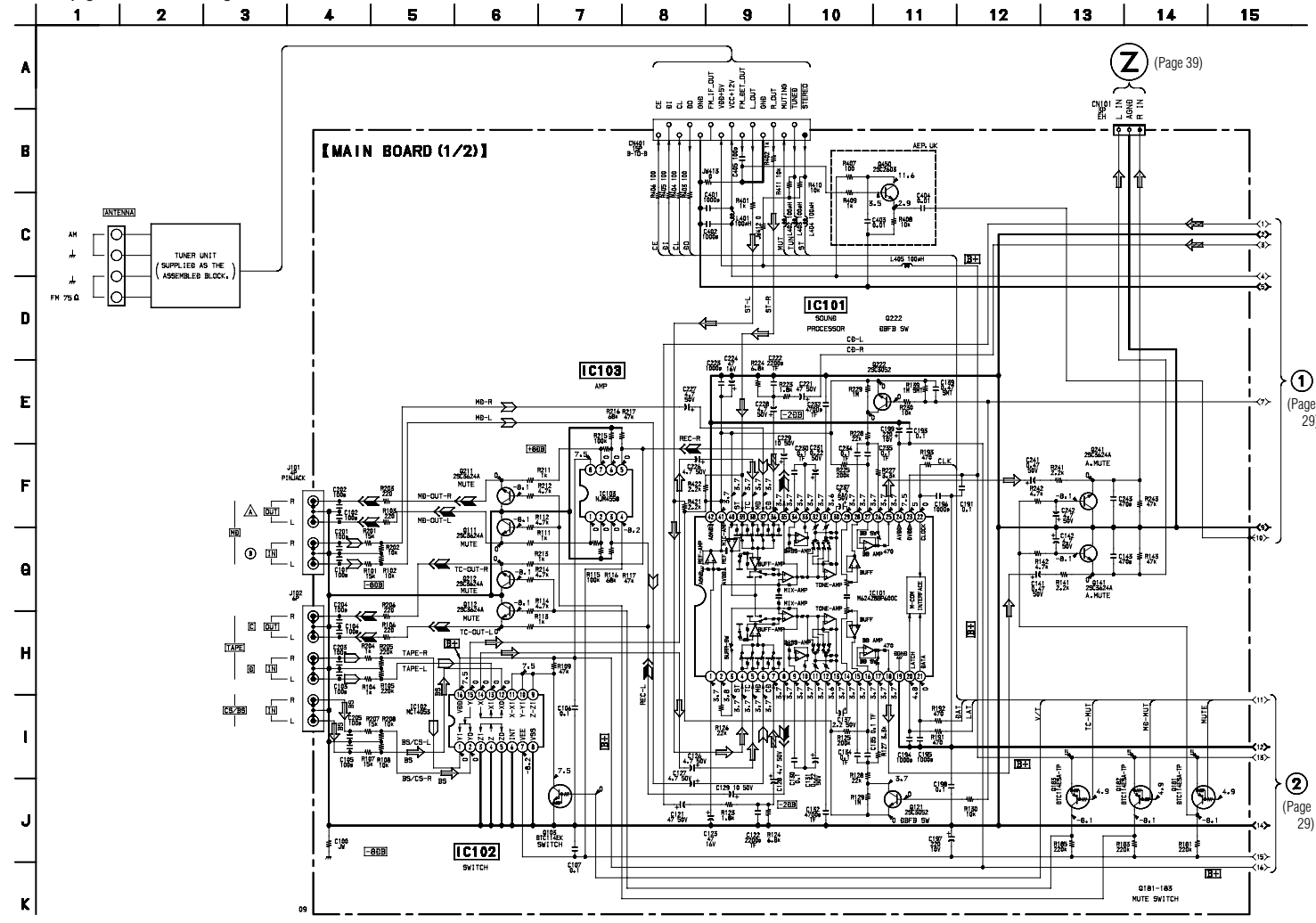





7-7. PRINTED WIRING BOARD – MAIN SECTION –  
 • See page 16 for Circuit Boards Location.

• Semiconductor Location

Ref. No.	Location
D351	A-6
D751	G-5
D752	G-5
D753	G-6
D755	G-6
D791	B-5
D792	B-5
D793	B-5
IC101	C-3
IC102	D-2
IC103	A-1
IC351	A-5
IC701	C-6
IC791	B-6
IC951	G-6
Q103	D-2
Q111	B-1
Q112	C-1
Q121	D-4
Q141	C-4
Q181	D-4
Q182	D-4
Q183	D-4
Q211	B-1
Q212	C-1
Q222	B-3
Q241	B-4
Q751	G-7
Q752	B-7
Q753	C-6
Q781	F-8
Q782	F-8
Q783	F-8
Q791	B-6
Q792	B-6
Q793	C-6

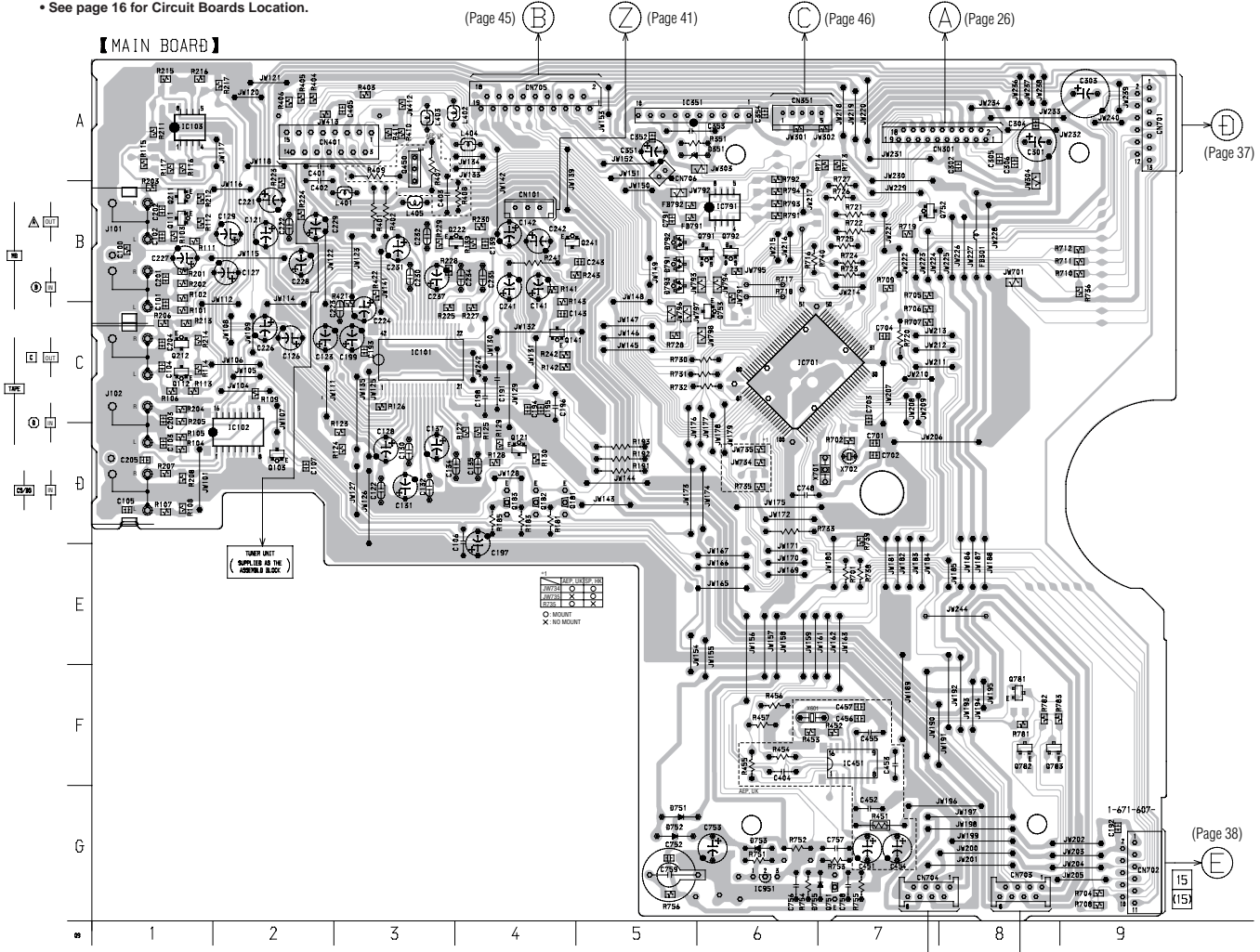

7-8. SCHEMATIC DIAGRAM – SUB SECTION –

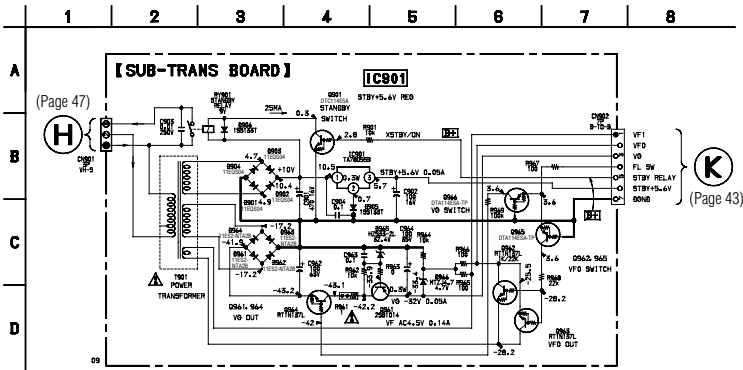

7-9. PRINTED WIRING BOARD – SUB SECTION –  
• See page 16 for Circuit Boards Location.

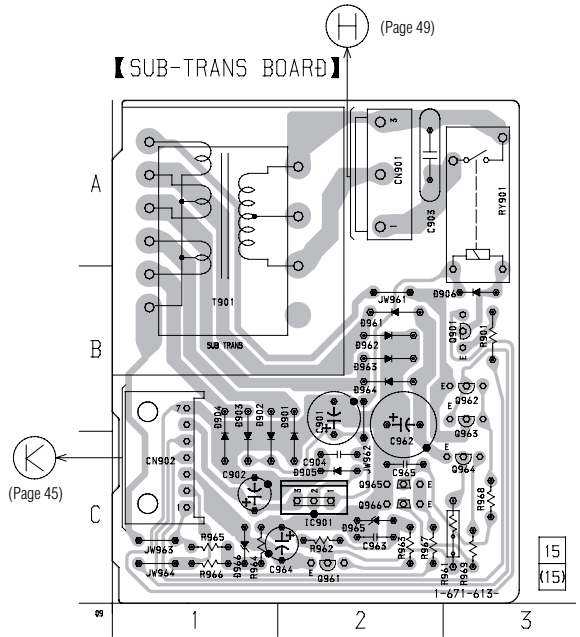

• Semiconductor Location

Ref. No.	Location	Ref. No.	Location
D901	B-2	D966	C-1
D902	B-1		
D903	B-1	IC901	C-2
D904	B-1		
D905	C-2	Q901	B-3
D906	B-3	Q961	C-2
D961	B-2	Q962	B-3
D962	B-2	Q963	C-3
D963	B-2	Q964	C-3
D964	B-2	Q965	C-2
D965	C-2	Q966	C-2

7-10. SCHEMATIC DIAGRAM - PANEL SECTION -

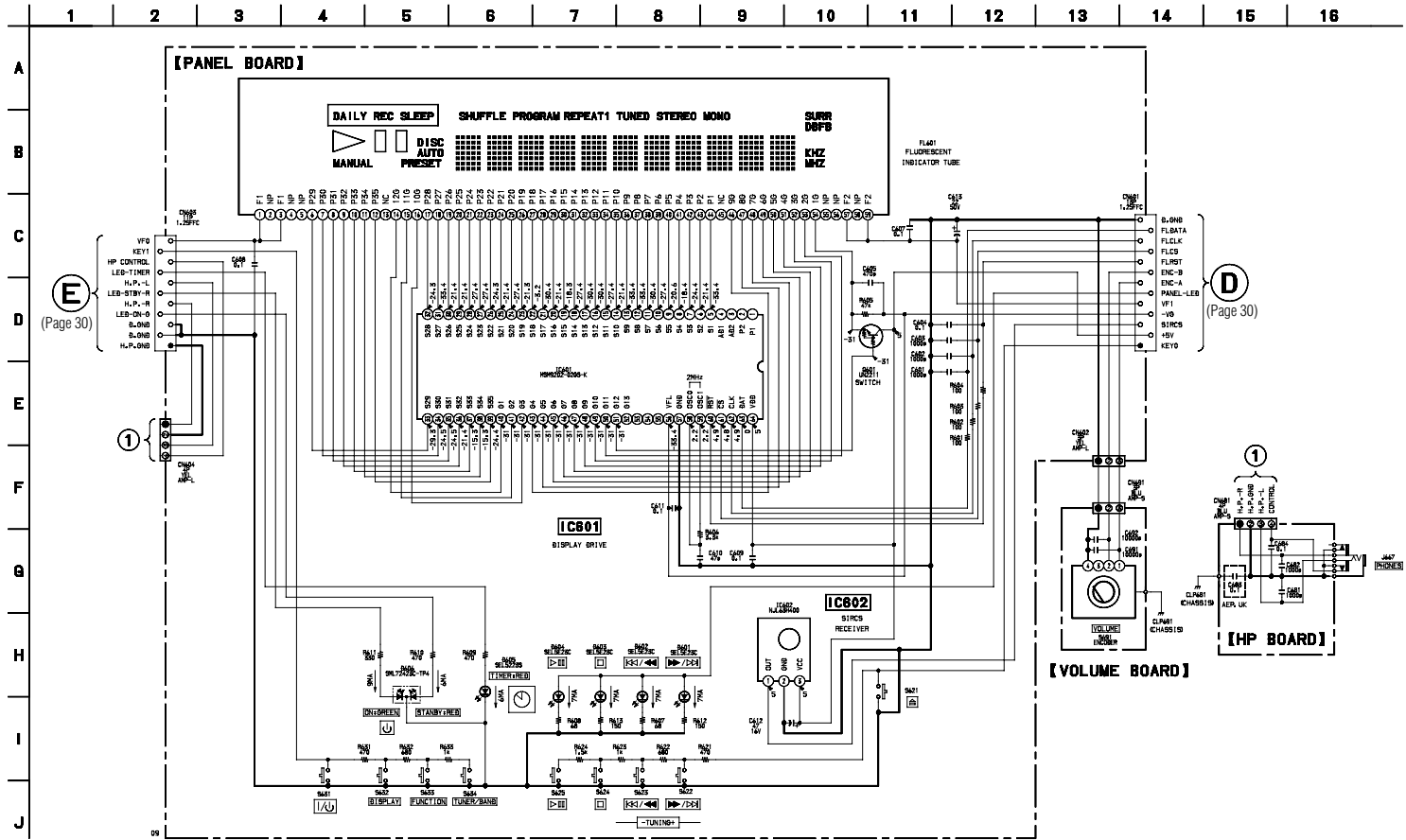





7-13. PRINTED WIRING BOARD – AMP SECTION –  
 • See page 16 for Circuit Boards Location.

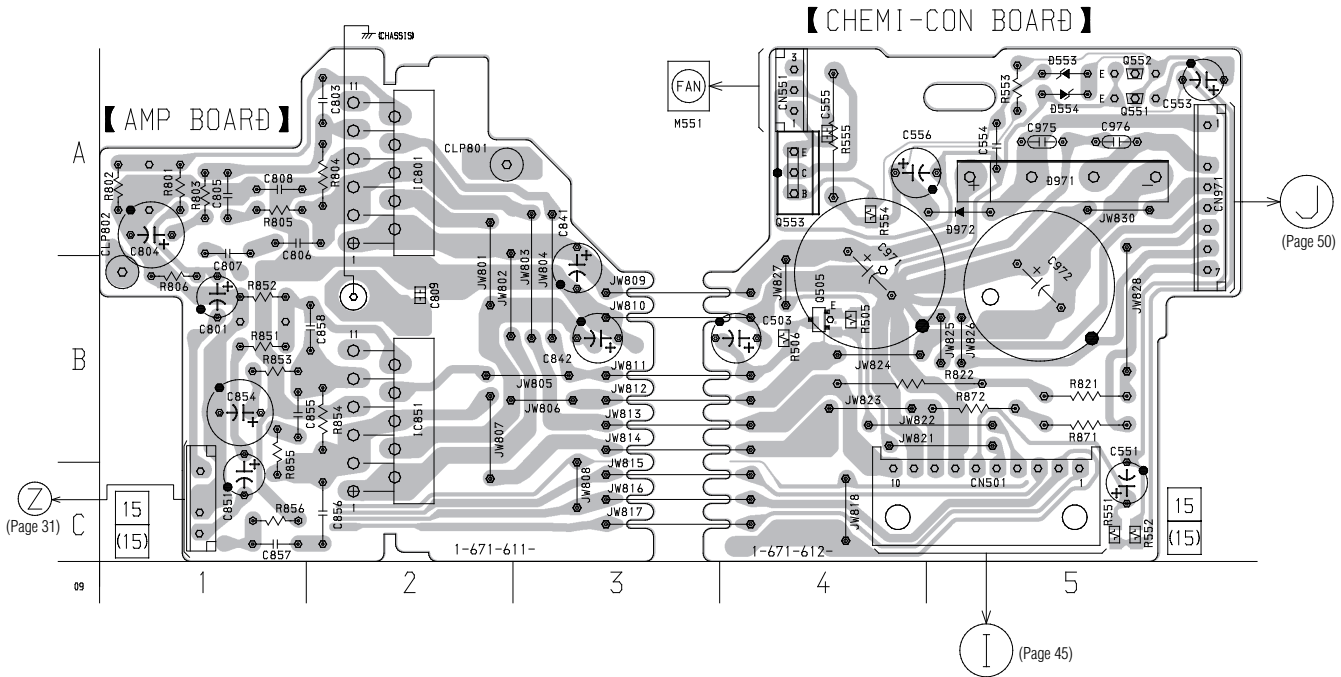

• Semiconductor Location

Ref. No.	Location
D553	A-5
D554	A-5
D971	A-5
D972	A-5
Q505	B-4
Q551	A-5
Q552	A-5
Q553	A-4

7-14. SCHEMATIC DIAGRAM - CONNECTOR SECTION -

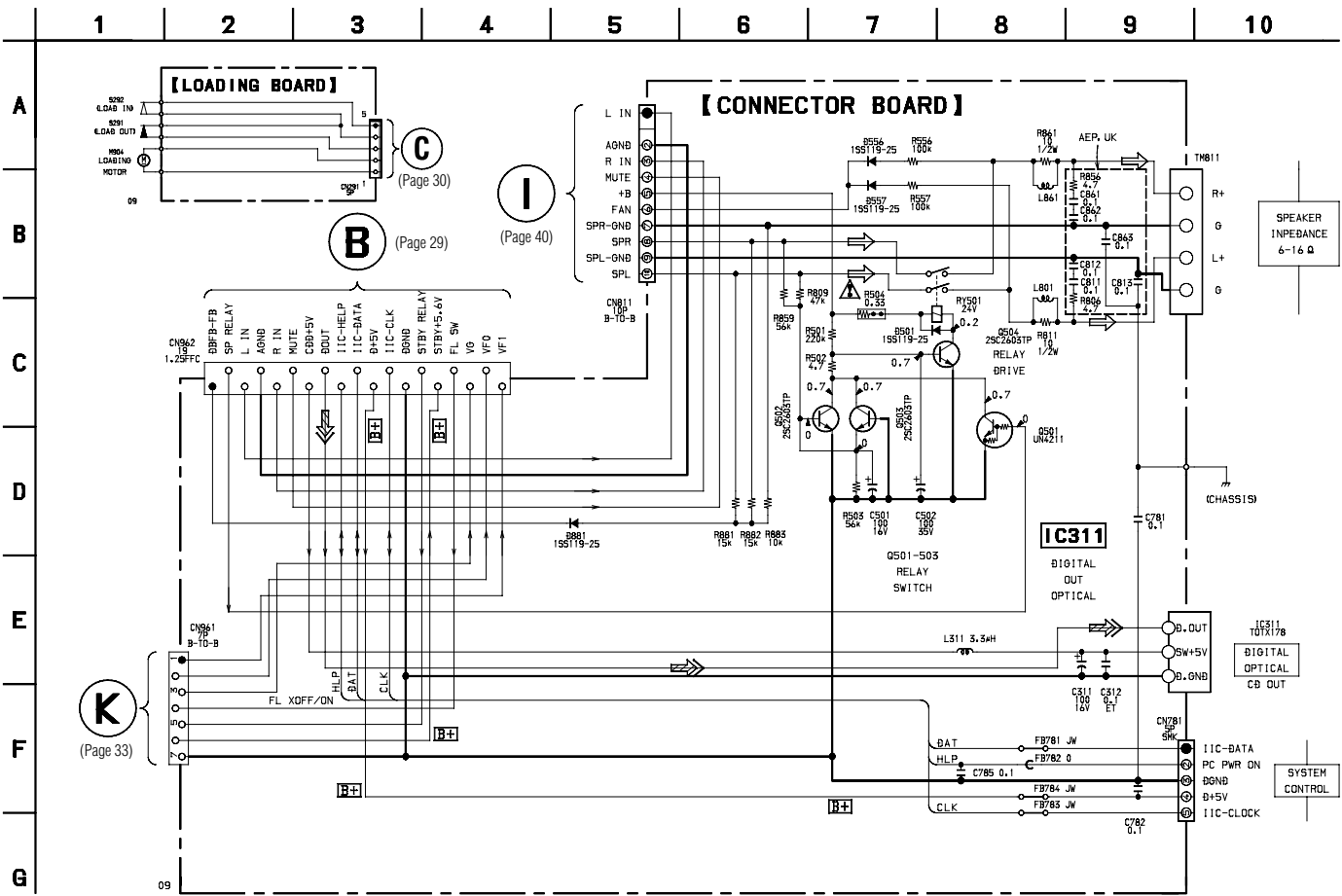

7-15. PRINTED WIRING BOARD – CONNECTOR SECTION –  
 • See page 16 for Circuit Boards Location.

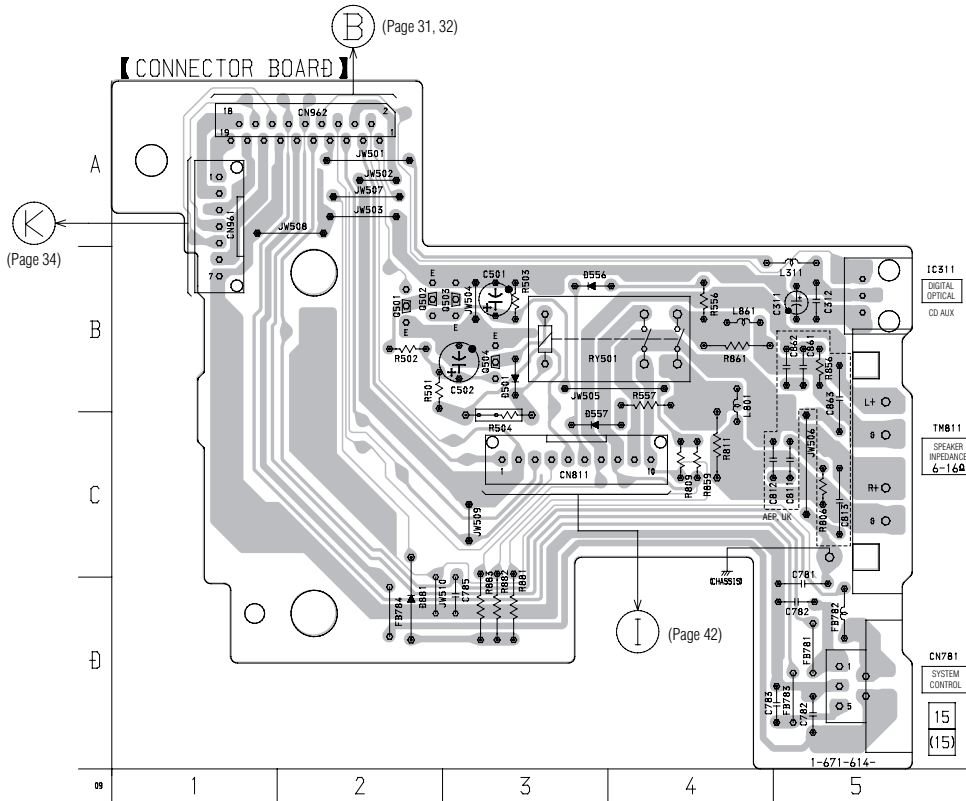

• Semiconductor Location

Ref. No.	Location
D501	B-3
D556	B-3
D557	C-3
D881	D-2
IC311	B-5
Q501	B-2
Q502	B-2
Q503	B-3
Q504	B-3

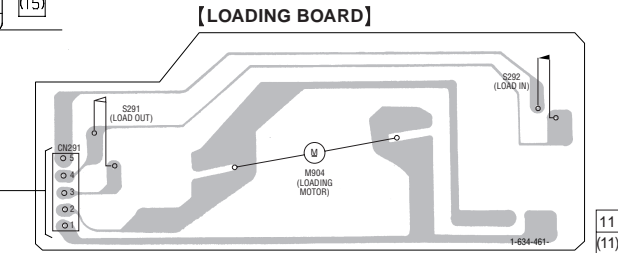



7-16. SCHEMATIC DIAGRAM – REG SECTION –

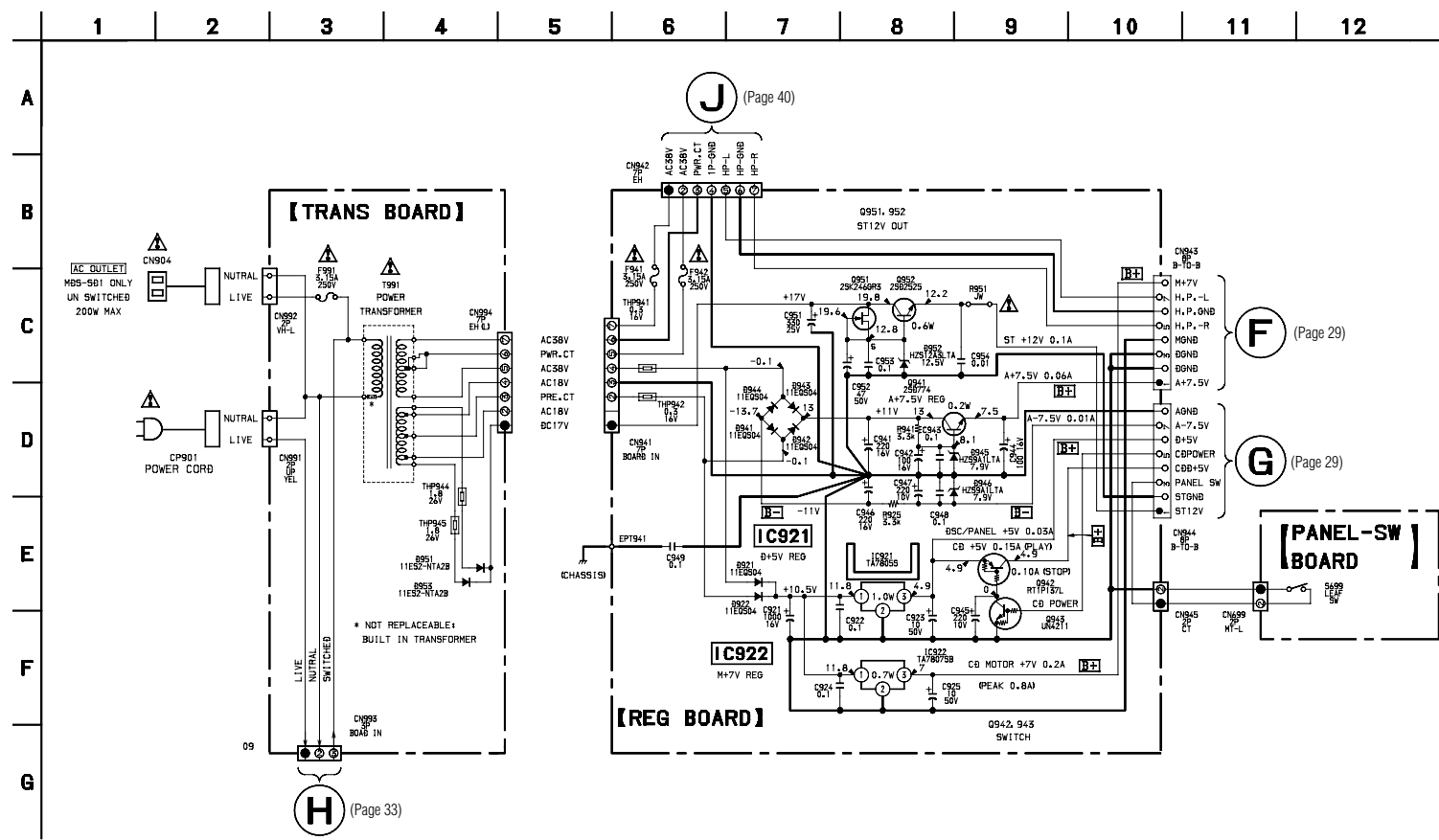

7-17. PRINTED WIRING BOARD – REG SECTION –  
 • See page 16 for Circuit Boards Location.

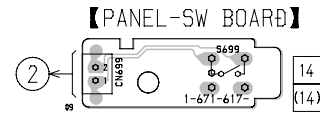
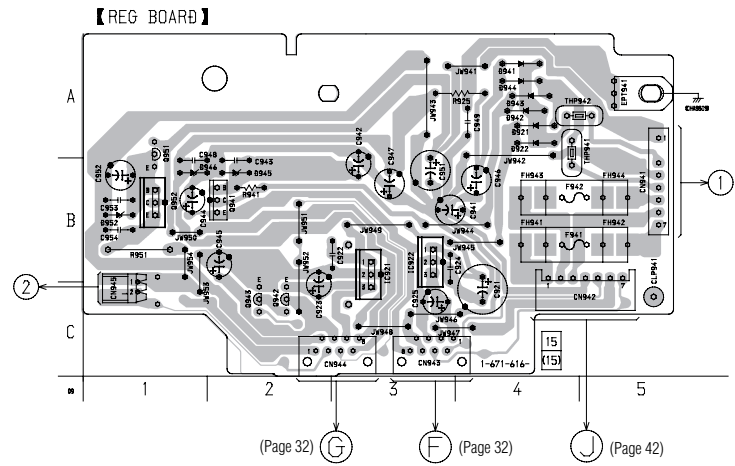
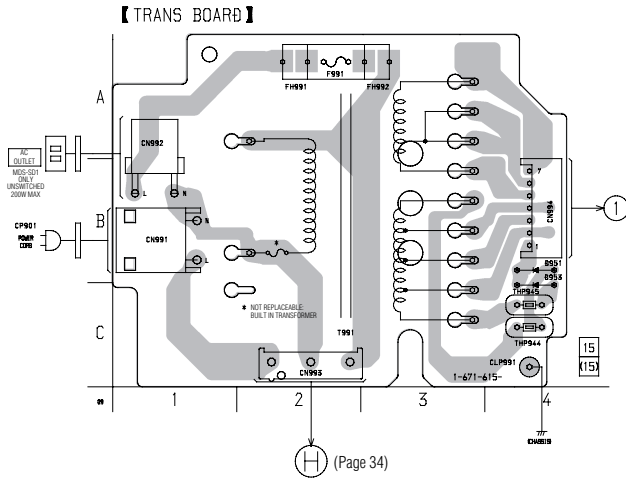

• Semiconductor Location

Ref. No.	Location
D921	A-4
D922	A-4
D941	A-4
D942	A-4
D943	A-4
D944	A-4
D945	B-2
D946	B-1
D952	B-1
IC921	B-3
IC922	B-3
Q941	B-2
Q942	C-2
Q943	C-2
Q951	A-1
Q952	B-1

7-18. IC BLOCK DIAGRAMS

• BD section

IC101 CXA1782BQ

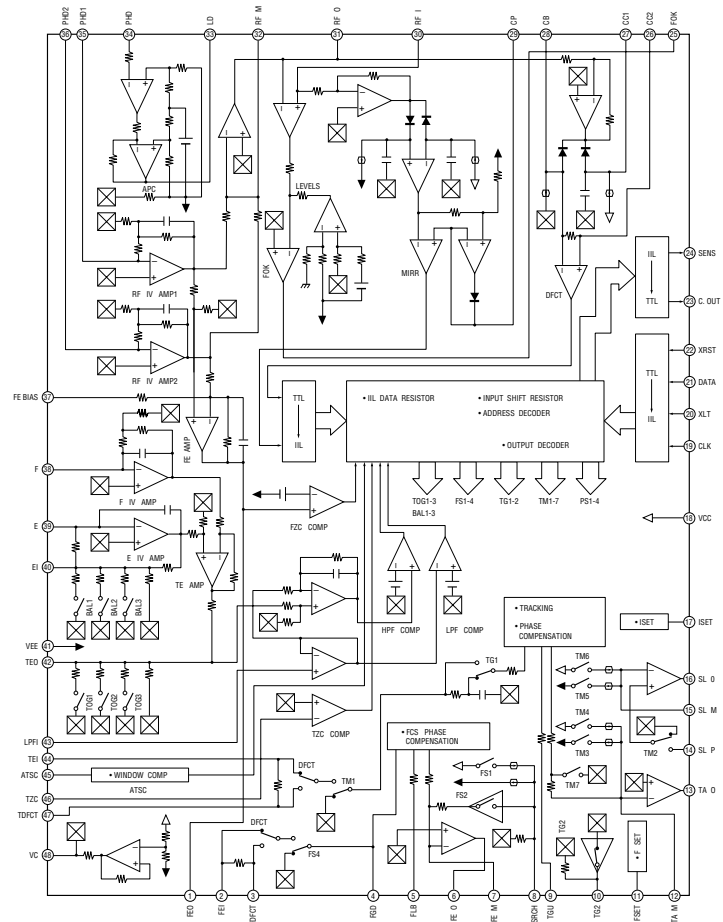

IC102 BA6397FP

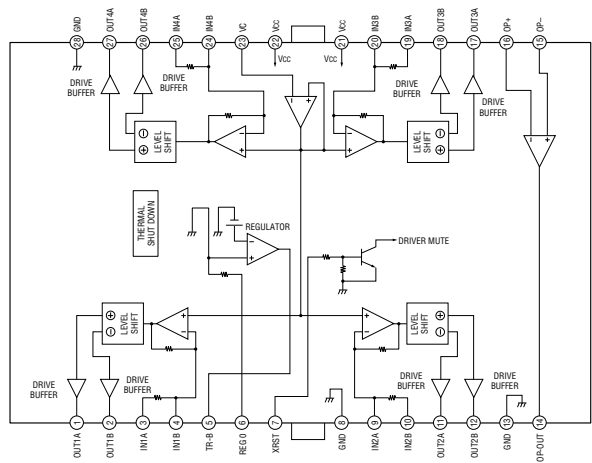

IC103 CXD2507AQ

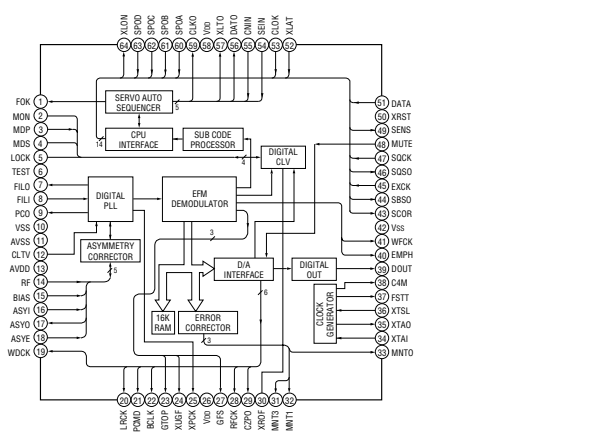

**IC104 PCM1710U-R**

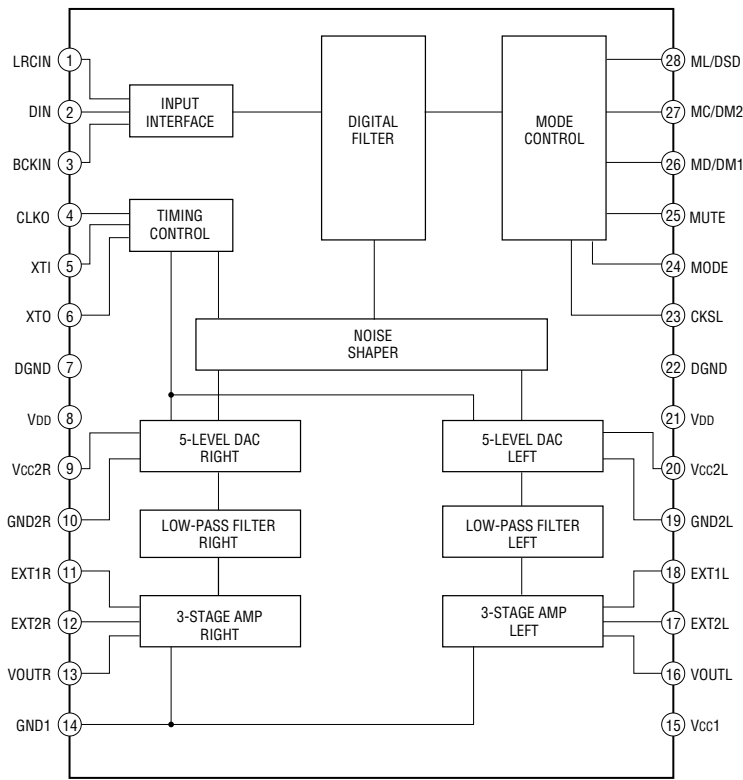

**- MAIN Section -**

**IC351 LB1641**

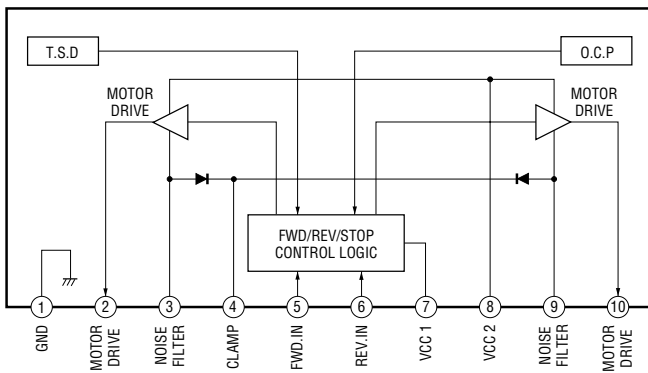

**IC791 P82B715TD.118**

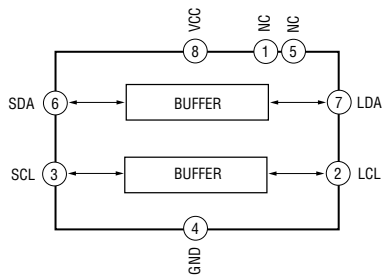

## 7-19. IC PIN FUNCTIONS

### • IC701 System Control ( $\mu$ PD780018AYGF-015-3BA) (MAIN Board)

Pin No.	Pin Name	I/O	Function
1	BD POWER	O	CD power control pin, "H":CD POWER ON
2	PANEL SW	I	Front cover open/close switch, "H":Open glass door, "L":Close glass door
3 to 7	–	I	Not used
8	AC.CUT	I	AC power connection signal, "L":Power is disconnected
9	VPP	–	Normally connected to the ground pin
10	X2	O	Main system clock output pin (5 MHz)
11	X1	I	Main system clock input pin (5 MHz)
12	VDD1	–	Positive power supply (+5V)
13	XT2	O	Sub system clock output pin (32 kHz)
14	XT1	I	Sub system clock output pin (32 kHz)
15	RESET	I	System reset input pin, "L":RESET
16, 17	–	I	Not used
18	ENCODER A	I	Encoder input pin for jogging
19	ENCODER B	I	Encoder input pin for jogging
20	RDSCLK	I	RDS clock input pin (Not used)
21	RDSDAT	I	RDS data input pin (Not used)
22	SCOR	I	SCOR input pin
23	VDD0	–	Positive power supply of port (+5V)
24	ADREF	–	Reference voltage of A/D converter (+5V)
25	KEY1	I	Key input pin (Analog input)
26	KEY0	I	Key input pin (Analog input)
27 to 30	–	I	Not used
31	HP-SW	I	Headphone detection SW, "L":No HP, "H":HP
32	–	I	Not used
33	AVSS	–	A/D converter ground potential
34	–	I	Not used
35	FL.DAT	O	Serial data output for FL tube control IC (MSM9202-02)
36	FL.CLK	O	Serial clock output for FL tube control IC (MSM9202-02)
37	FL.LAT	O	Chip select output for FL tube control IC (MSM9202-02)
38	FL.RST	O	Reset signal output for FL tube control IC (MSM9202-02)
39	–	I	Not used
40	VSS1	–	Ground potential other than port and analog
41, 42	–	I	Not used
43	SQSI	I	CD sub code data input
44	–	I	Not used
45	SQCK	O	Clock output for reading CD sub code
46 to 48	–	I	Not used
49	IN-SW	I	CD tray close completion detection input, "L":CLOSE
50	OUT-SW	I	CD tray open completion detection input, "L":OPEN
51	HELP	I	Pin requesting power ON from the PC link adapter (optional), Normally "H"
52	FSW	O	Focus gain switch
53	SENSE	I	SENSE input pin
54	–	I	Not used
55	IIC DAT	I/O	System control communication data input/output pin
56	IIC CLOCK	I/O	System control communication clock input/output pin
57	CD-CLK	O	Serial clock for CD control
58	CD-DATA	O	Serial data for CD control
59	DF-LAT	O	Chip select signal for DA/DF
60	DSP-LAT	O	DSP IC and SSP IC chip select

Pin No.	Pin Name	I/O	Function
61	LOAD IN	O	Tray loading motor control signal, "L":Loading
62	LOAD OUT	O	Tray loading motor control signal, "L":When OPEN
63	BD.RESET	O	IC reset signal for CD control, "L":RESET
64	LIGHT	O	BLUE LED control port of front panel, "L":LED ON
65	SDATA	O	Serial data for SOUND PROCESSOR IC101 (M62428AFP)
66	SCLOCK	O	Serial clock for SOUND PROCESSOR IC101 (M62428AFP)
67	SLAT1	O	Chip select for SOUND PROCESSOR IC101 (M62428AFP)
68	MUTE1	O	Audio mute signal, "H":Power amplifier ICs (IC801, IC851) MUTE
69	MUTE2	O	Audio mute signal, "L":Line mute (Q141, Q241) MUTE
70	STANDBY LED	O	Signal controlling LED which lights when power is OFF, "L":LED ON
71	VSS0	-	Ground potential of port
72	ON LED	O	Signal controlling LED which lights when power is ON, "L":LED ON
73	TIMER LED	O	Signal controlling LED which lights in timer standby, "H":LED ON
74	-	I	Not used
75	FL DISP SW	O	Power ON/OFF signal for FL display, "H":FL display ON
76	SP RELAY SW	O	Speaker relay control signal, "L":Speaker relay ON
77 to 80	-	I	Not used
81	ON/XSTBY	O	System power control signal, "H":Standby relay ON
82	STEREO	I	Tuner stereo signal, "L":Stereo
83	TUNED	I	Tuner selection OK signal, "L":TUNED
84	ST IDATA	I	Serial input data for tuner
85	ST ODATA	O	Serial output data for tuner
86	ST.CLOCK	O	Serial clock for tuner
87	ST LATCH	O	Chip select for tuner
88	ST MUTE	O	Tuner mute output
89	ST POWER	O	Tuner power signal (Not used)
90	SIRCS	I	SIRCS code input signal (Remote control signal input)
91	PCL	I	32 KHz clock monitor out 32.768 kHz signal is output in the test mode (Refer to page 12.)
92, 93	-	I	Not used
94	DEST1	I	Destination differentiation signal (Fixed at "H")
95	DEST2	I	Destination differentiation signal (Fixed at "L")
96	-	I	Not used
97	HP MUTE	O	HP mute signal output
98	MD-MUTE	O	MD REC OUT control signal "L":MD REC OUT MUTE ("L" only for MD function)
99	TC-MUTE	O	REC OUT control signal of TAPE "L":TAPE REC OUT MUTE ("L" only for TAPE function)
100	V/T	O	Function control signal "H":TAPE, "L":CS/BS

## SECTION 8 EXPLODED VIEWS

**NOTE:**

- Items marked “\*” are not stocked since they are seldom required for routine service. Some delay should be anticipated when ordering these items.
- The mechanical parts with no reference number in the exploded views are not supplied.

- Hardware (# mark) list and accessories and packing materials are given in the last of this parts list.
- Abbreviation  
 HK : Hong Kong model  
 SP : Singapore model

The components identified by mark  $\triangle$  or dotted line with mark  $\triangle$  are critical for safety. Replace only with part number specified.

### 8-1. FRONT PANEL SECTION

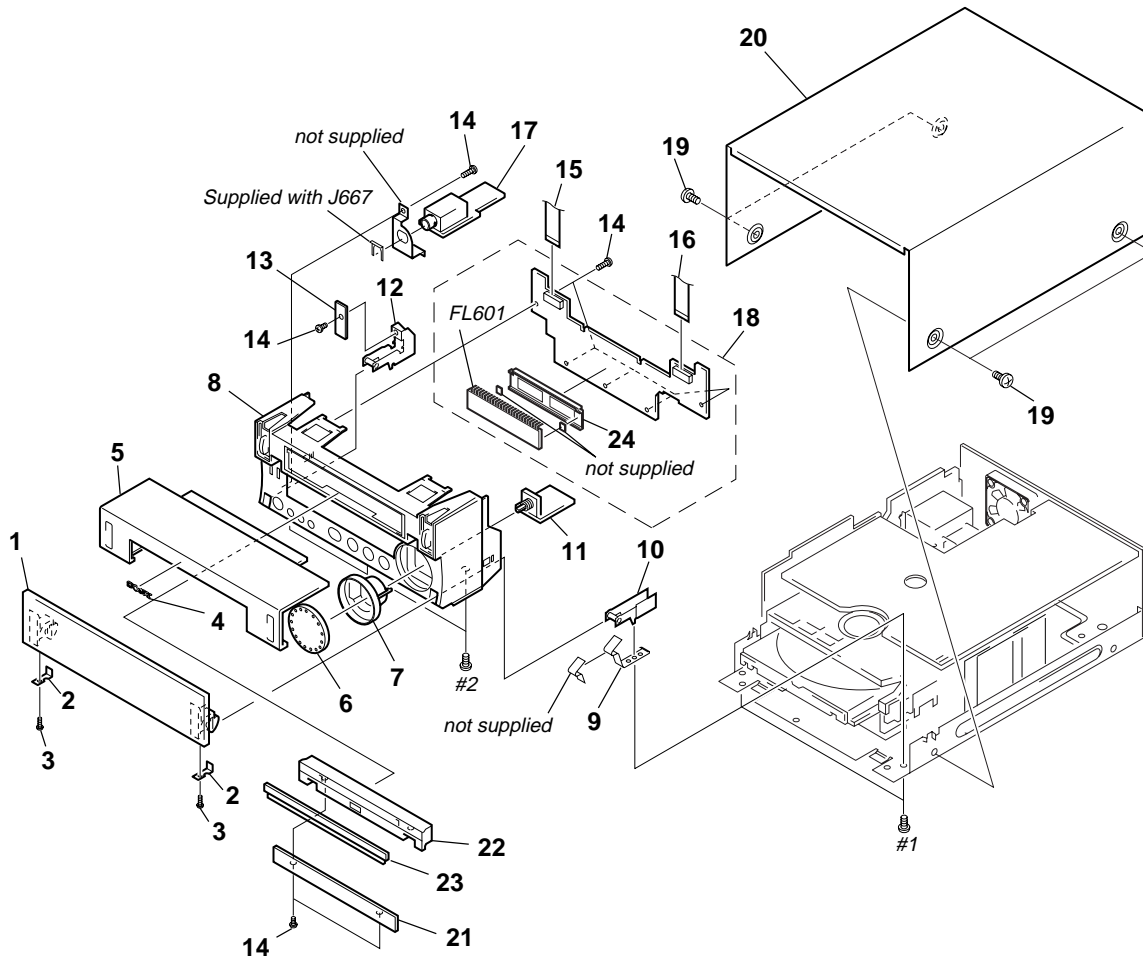

Ref. No.	Part No.	Description	Remark	Ref. No.	Part No.	Description	Remark
1	X-4950-580-1	GLASS ASSY (CD)		14	4-951-620-01	SCREW (2.6X8), +BVTP	
2	4-212-584-01	BRACKET (SHAFT)		15	1-769-940-11	WIRE (FLAT TYPE) (11 CORE)	
3	4-993-007-01	SCREW (M2.6X6), +P TAPPING		16	1-769-972-11	WIRE (FLAT TYPE) (13 CORE)	
4	4-942-636-21	EMBLEM (NO.3.5), SONY		* 17	1-671-609-11	HP BOARD	
5	4-212-538-11	PANEL (AL-CD), FRONT		* 18	A-4419-060-A	PANEL BOARD, COMPLETE	
6	X-4950-364-1	KNOB (VOL) ASSY		19	3-363-099-51	SCREW (CASE 3 TP2)	
7	4-212-542-11	RING (VOL)		* 20	4-212-561-31	CASE	
8	X-4950-995-1	PANEL ASSY (CD), FRONT		21	4-212-540-11	PANEL (AL-CD), LOADING	
9	4-212-580-11	SPRING (GLASS)		22	4-212-541-11	PANEL (CD), LOADING	
10	X-4950-999-1	BRACKET (R) ASSY		23	4-212-545-11	PLATE (CD), ORNAMENTAL	
* 11	1-671-610-11	VOLUME BOARD		* 24	4-212-590-11	HOLDER (FL)	
12	X-4950-998-1	BRACKET (L) ASSY		FL601	1-517-805-11	INDICATOR TUBE, FLUORESCENT	
* 13	1-671-617-11	PANEL-SW BOARD					

## 8-2. CHASSIS SECTION

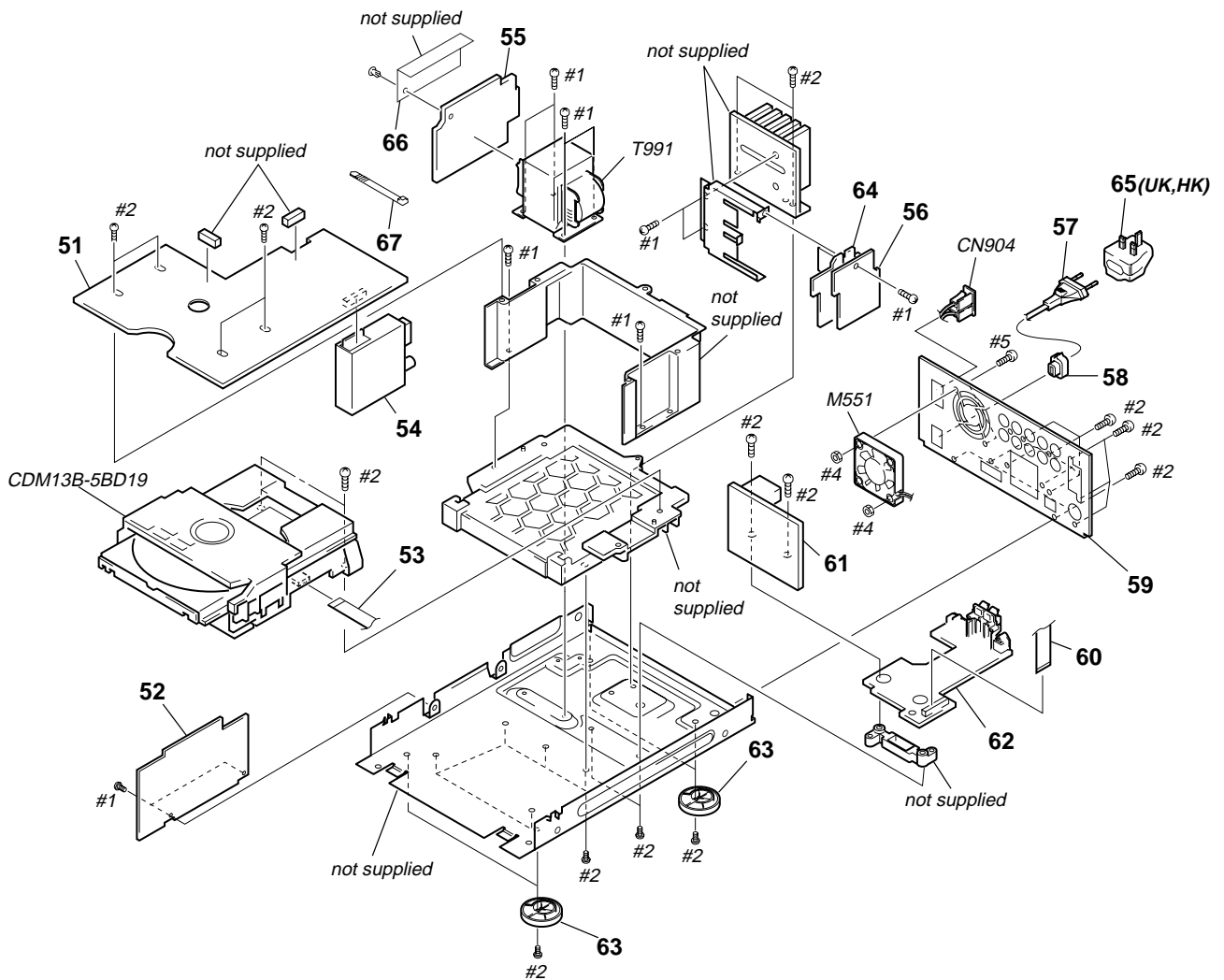

Ref. No.	Part No.	Description	Remark	Ref. No.	Part No.	Description	Remark
* 51	A-4419-059-A	MAIN BOARD, COMPLETE (AEP,UK)		* 61	A-4419-065-A	SUB-TRANS BOARD, COMPLETE	
* 51	A-4419-070-A	MAIN BOARD, COMPLETE (SP,HK)		* 62	1-671-614-11	CONNECTOR BOARD	
* 52	A-4419-068-A	REG BOARD, COMPLETE		63	X-4950-994-1	FOOT ASSY	
53	1-790-305-11	WIRE (FLAT TYPE) (19 CORE)		* 64	1-671-611-11	AMP BOARD	
54	1-693-408-11	TUNER		Δ 65	1-770-019-11	ADAPTOR, CONVERSION PLUG 3P (UK,HK)	
* 55	1-671-615-11	TRANS BOARD		66	3-531-576-01	RIVET	
* 56	A-4419-064-A	CHEMI-CON BOARD, COMPLETE		67	3-655-653-01	BAND (TAITON), BINDING	
Δ 57	1-575-651-91	CORD, POWER		Δ CN904	1-526-794-11	OUTLET, AC	
* 58	3-703-244-00	BUSHING (2104), CORD		M551	1-698-997-21	FAN, D.C.	
* 59	4-212-564-11	PANEL (CD), BACK		Δ T991	1-433-478-11	TRANSFORMER, POWER	
60	1-773-108-11	WIRE (FLAT TYPE) (19 CORE)(100mm)					



### 8-3. MECHANISM DECK SECTION (CDM13B-5BD19)

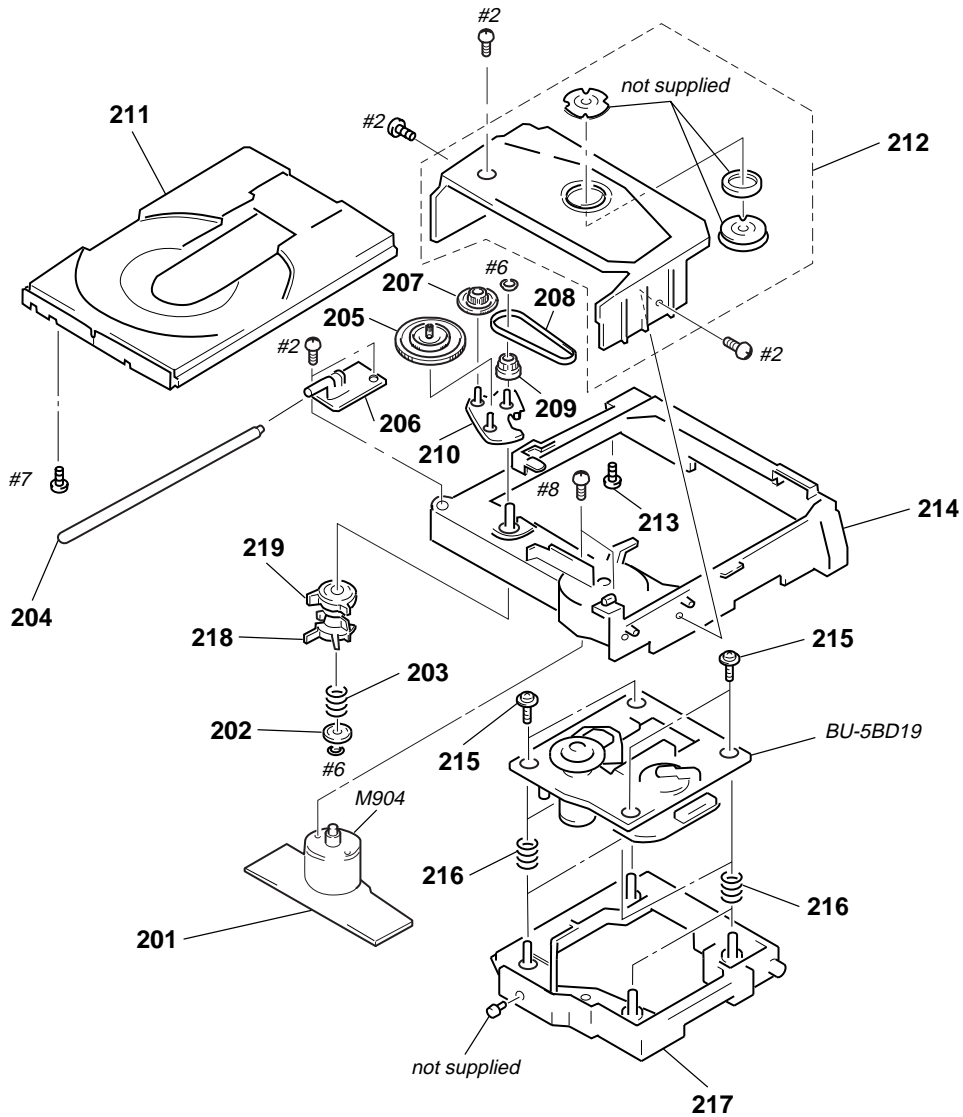

Ref. No.	Part No.	Description	Remark	Ref. No.	Part No.	Description	Remark
* 201	1-634-461-11	LOADING BOARD		211	4-944-012-01	TABLE, DISC	
202	4-927-654-01	WASHER (LIMITER)		212	A-4604-752-A	HOLDER (MG) ASSY	
203	3-659-338-00	SPRING, COMPRESSION		* 213	4-917-583-21	BRACKET, YOKE	
204	4-929-764-01	SHAFT (TABLE GUIDE)		214	X-4941-462-1	CHASSIS (MD) ASSY	
205	4-927-620-01	GEAR (P)		215	4-933-134-01	SCREW (+PTPWH M2.6X6)	
206	4-944-006-11	BEARING		216	4-958-593-01	SPRING (BU), COMPRESSION	
207	4-927-628-01	GEAR (C)		217	4-929-747-01	HOLDER (BU)	
208	4-927-649-01	BELT		218	4-929-727-01	CAM (A)	
209	4-929-724-01	PULLEY (B)		219	4-929-729-01	CAM (B)	
210	X-4947-265-1	ARM ASSY, SWING		M904	A-4660-307-A	MOTOR (L) ASSY (LOADING)	

### 8-4. BASE UNIT SECTION (BU-5BD19)

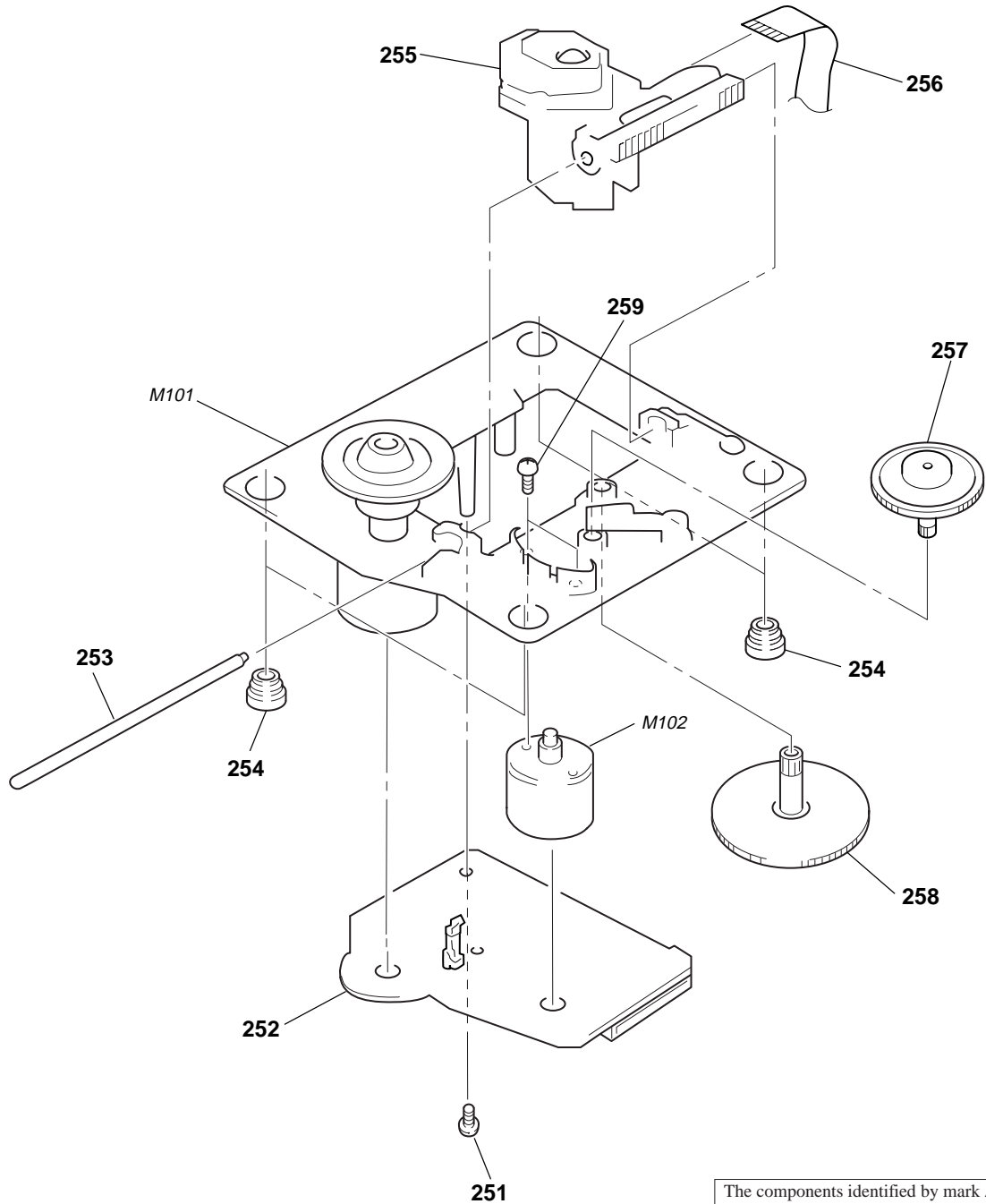

The components identified by mark  $\triangle$  or dotted line with mark  $\triangle$  are critical for safety. Replace only with part number specified.

Ref. No.	Part No.	Description	Remark	Ref. No.	Part No.	Description	Remark
	251	4-951-620-01	SCREW (2.6X8), +BVTP		257	4-917-567-01	GEAR (M)
*	252	A-4673-402-B	BD BOARD, COMPLETE		258	4-917-564-01	GEAR (P), FLATNESS
	253	4-917-565-01	SHAFT, SLED		259	3-713-786-51	SCREW +P 2X3
	254	4-951-940-01	INSULATOR (BU)		M101	X-4917-523-4	MOTOR ASSY (SPINDLE)
$\triangle$	255	8-848-379-31	OPTICAL PICK-UP KSS-213B/S-N		M102	X-4917-504-1	MOTOR ASSY (SLED)
	256	1-769-069-11	WIRE (FLAT TYPE) (16 CORE)				

## SECTION 9 ELECTRICAL PARTS LIST

## Note:

The components identified by mark  $\Delta$  or dotted line with mark  $\Delta$  are critical for safety.  
Replace only with part number specified.

When indicating parts by reference number, please include the board name.

- Due to standardization, replacements in the parts list may be different from the parts specified in the diagrams or the components used on the set.
- -XX, -X mean standardized parts, so they may have some difference from the original one.
- Items marked "\*" are not stocked since they are seldom required for routine service. Some delay should be anticipated when ordering these items.
- RESISTORS  
All resistors are in ohms  
METAL: Metal-film resistor  
METAL OXIDE: Metal Oxide-film resistor  
F : nonflammable
- SEMICONDUCTORS  
In each case, u:  $\mu$ , for example:  
uA...:  $\mu$  A..., uPA...:  $\mu$  PA..., uPB...:  $\mu$  PB...,  
uPC...:  $\mu$  PC..., uPD...:  $\mu$  PD...
- CAPACITORS  
uF :  $\mu$  F
- COILS  
uH :  $\mu$  H
- Abbreviation  
HK : Hong Kong model  
SP : Singapore model

Ref. No.	Part No.	Description	Remark	Ref. No.	Part No.	Description	Remark
*	1-671-611-11	AMP BOARD *****		C103	1-164-346-11	CERAMIC CHIP 1uF	16V
		< CAPACITOR >		C105	1-163-038-91	CERAMIC CHIP 0.1uF	25V
C801	1-124-720-11	ELECT 4.7uF	20% 50V	C106	1-164-690-91	CERAMIC CHIP 0.0022uF	5% 50V
C803	1-162-215-31	CERAMIC 47PF	5% 50V	C107	1-164-690-91	CERAMIC CHIP 0.0022uF	5% 50V
C804	1-124-724-11	ELECT 47uF	20% 50V	C108	1-163-021-91	CERAMIC CHIP 0.01uF	10% 50V
C805	1-162-215-31	CERAMIC 47PF	5% 50V	C109	1-163-021-91	CERAMIC CHIP 0.01uF	10% 50V
C806	1-164-159-11	CERAMIC 0.1uF	50V	C110	1-163-989-11	CERAMIC CHIP 0.033uF	10% 25V
C807	1-164-159-11	CERAMIC 0.1uF	50V	C111	1-163-038-91	CERAMIC CHIP 0.1uF	25V
C808	1-164-159-11	CERAMIC 0.1uF	50V	C112	1-163-038-91	CERAMIC CHIP 0.1uF	25V
C809	1-163-038-91	CERAMIC 0.1uF	25V	C113	1-164-690-91	CERAMIC CHIP 0.0022uF	5% 50V
C841	1-126-948-11	ELECT 100uF	20% 35V	C114	1-164-005-11	CERAMIC CHIP 0.47uF	25V
C842	1-126-948-11	ELECT 100uF	20% 35V	C115	1-126-607-11	ELECT CHIP 47uF	20% 4V
C851	1-124-720-11	ELECT 4.7uF	20% 50V	C116	1-163-016-00	CERAMIC CHIP 0.0039uF	10% 50V
C853	1-162-215-31	CERAMIC 47PF	5% 50V	C117	1-164-005-11	CERAMIC CHIP 0.47uF	25V
C854	1-124-724-11	ELECT 47uF	20% 50V	C118	1-107-823-11	CERAMIC CHIP 0.47uF	10% 16V
C855	1-162-215-31	CERAMIC 47PF	5% 50V	C119	1-163-038-91	CERAMIC CHIP 0.1uF	25V
C856	1-164-159-11	CERAMIC 0.1uF	50V	C120	1-135-201-11	TANTALUM CHIP 10uF	20% 4V
C857	1-164-159-11	CERAMIC 0.1uF	50V	C121	1-163-038-91	CERAMIC CHIP 0.1uF	25V
		< IC >		C122	1-163-021-91	CERAMIC CHIP 0.01uF	10% 50V
IC801	8-759-331-41	IC LM3876TF		C123	1-163-038-91	CERAMIC CHIP 0.1uF	25V
IC851	8-759-331-41	IC LM3876TF		C124	1-126-607-11	ELECT CHIP 47uF	20% 4V
		< RESISTOR >		C125	1-163-021-91	CERAMIC CHIP 0.01uF	10% 50V
R801	1-249-417-11	CARBON 1K	5% 1/4W F	C126	1-163-038-91	CERAMIC CHIP 0.1uF	25V
R802	1-249-437-11	CARBON 47K	5% 1/4W	C127	1-164-690-91	CERAMIC CHIP 0.0022uF	5% 50V
R803	1-249-417-11	CARBON 1K	5% 1/4W F	C128	1-163-135-00	CERAMIC CHIP 560PF	5% 50V
R804	1-249-437-11	CARBON 47K	5% 1/4W	C129	1-163-038-91	CERAMIC CHIP 0.1uF	25V
R805	1-249-433-11	CARBON 22K	5% 1/4W	C130	1-164-336-11	CERAMIC CHIP 0.33uF	25V
R806	1-249-389-11	CARBON 4.7	5% 1/4W F	C131	1-163-038-91	CERAMIC CHIP 0.1uF	25V
R851	1-249-417-11	CARBON 1K	5% 1/4W F	C132	1-163-037-11	CERAMIC CHIP 0.022uF	10% 25V
R852	1-249-437-11	CARBON 47K	5% 1/4W	C133	1-163-145-00	CERAMIC CHIP 0.0015uF	5% 50V
R853	1-249-417-11	CARBON 1K	5% 1/4W F	C134	1-164-346-11	CERAMIC CHIP 1uF	16V
R854	1-249-437-11	CARBON 47K	5% 1/4W	C135	1-163-251-11	CERAMIC CHIP 100PF	5% 50V
R855	1-249-433-11	CARBON 22K	5% 1/4W	C136	1-164-005-11	CERAMIC CHIP 0.47uF	25V
R856	1-249-389-11	CARBON 4.7	5% 1/4W F	C137	1-163-021-91	CERAMIC CHIP 0.01uF	10% 50V
		*****		C139	1-163-235-11	CERAMIC CHIP 22PF	5% 50V
*	A-4673-402-B	BD BOARD, COMPLETE *****		C140	1-163-235-11	CERAMIC CHIP 22PF	5% 50V
		< CAPACITOR >		C141	1-163-038-91	CERAMIC CHIP 0.1uF	25V
C101	1-126-607-11	ELECT CHIP 47uF	20% 4V	C142	1-163-038-91	CERAMIC CHIP 0.1uF	25V
C102	1-163-275-11	CERAMIC CHIP 0.001uF	5% 50V	C145	1-135-201-11	TANTALUM CHIP 10uF	20% 4V
				C146	1-135-201-11	TANTALUM CHIP 10uF	20% 4V
				C147	1-163-275-11	CERAMIC CHIP 0.001uF	5% 50V
				C148	1-163-275-11	CERAMIC CHIP 0.001uF	5% 50V
				C149	1-164-346-11	CERAMIC CHIP 1uF	16V
				C153	1-135-259-11	TANTAL. CHIP 10uF	20% 6.3V
				C154	1-163-235-11	CERAMIC CHIP 22PF	5% 50V

Ref. No.	Part No.	Description	Remark
		< CONNECTOR >	
CNU101	1-770-014-11	CONNECTOR, FFC/FPC 16P	
CNU102	1-770-013-11	CONNECTOR, FFC/FPC 19P	
		< IC >	
IC101	8-752-074-34	IC CXA1782BQ	
IC102	8-759-291-06	IC BA6397FP	
IC103	8-752-372-94	IC CXD2507AQ	
IC104	8-759-185-29	IC PCM1710U-B	
		< TRANSISTOR >	
Q101	8-729-010-08	TRANSISTOR MSB710-R	
Q102	8-729-424-08	TRANSISTOR UN2111	
Q103	8-729-421-22	TRANSISTOR UN2211	
		< RESISTOR >	
R102	1-216-001-00	METAL CHIP 10	5% 1/10W
R103	1-216-049-91	RES,CHIP 1K	5% 1/10W
R104	1-216-097-91	RES,CHIP 100K	5% 1/10W
R105	1-216-093-91	RES,CHIP 68K	5% 1/10W
R106	1-216-093-91	RES,CHIP 68K	5% 1/10W
R107	1-216-093-91	RES,CHIP 68K	5% 1/10W
R108	1-216-093-91	RES,CHIP 68K	5% 1/10W
R109	1-216-097-91	RES,CHIP 100K	5% 1/10W
R112	1-216-083-00	METAL CHIP 27K	5% 1/10W
R113	1-216-083-00	METAL CHIP 27K	5% 1/10W
R114	1-216-101-00	METAL CHIP 150K	5% 1/10W
R115	1-216-101-00	METAL CHIP 150K	5% 1/10W
R116	1-216-061-00	METAL CHIP 3.3K	5% 1/10W
R117	1-216-069-00	METAL CHIP 6.8K	5% 1/10W
R118	1-216-049-91	RES,CHIP 1K	5% 1/10W
R119	1-216-089-91	RES,CHIP 47K	5% 1/10W
R120	1-216-089-91	RES,CHIP 47K	5% 1/10W
R121	1-216-114-00	RES,CHIP 510K	5% 1/10W
R122	1-216-097-91	RES,CHIP 100K	5% 1/10W
R123	1-216-099-00	METAL CHIP 120K	5% 1/10W
R124	1-216-091-00	METAL CHIP 56K	5% 1/10W
R125	1-216-069-00	METAL CHIP 6.8K	5% 1/10W
R126	1-216-063-91	RES,CHIP 3.9K	5% 1/10W
R127	1-216-089-91	RES,CHIP 47K	5% 1/10W
R128	1-216-105-91	RES,CHIP 220K	5% 1/10W
R129	1-216-049-91	RES,CHIP 1K	5% 1/10W
R130	1-216-079-00	METAL CHIP 18K	5% 1/10W
R131	1-216-079-00	METAL CHIP 18K	5% 1/10W
R132	1-216-061-00	METAL CHIP 3.3K	5% 1/10W
R133	1-216-061-00	METAL CHIP 3.3K	5% 1/10W
R134	1-216-065-91	RES,CHIP 4.7K	5% 1/10W
R135	1-216-065-91	RES,CHIP 4.7K	5% 1/10W
R136	1-216-073-00	METAL CHIP 10K	5% 1/10W
R137	1-216-065-91	RES,CHIP 4.7K	5% 1/10W
R138	1-216-049-91	RES,CHIP 1K	5% 1/10W
R139	1-216-033-00	METAL CHIP 220	5% 1/10W
R140	1-216-081-00	METAL CHIP 22K	5% 1/10W
R141	1-216-061-00	METAL CHIP 3.3K	5% 1/10W
R142	1-216-061-00	METAL CHIP 3.3K	5% 1/10W
R143	1-216-121-91	RES,CHIP 1M	5% 1/10W
R144	1-216-073-00	METAL CHIP 10K	5% 1/10W

Ref. No.	Part No.	Description	Remark
R145	1-216-097-91	RES,CHIP 100K	5% 1/10W
R146	1-216-097-91	RES,CHIP 100K	5% 1/10W
R147	1-216-049-91	RES,CHIP 1K	5% 1/10W
R148	1-216-049-91	RES,CHIP 1K	5% 1/10W
R149	1-216-049-91	RES,CHIP 1K	5% 1/10W
R150	1-216-037-00	METAL CHIP 330	5% 1/10W
R151	1-216-037-00	METAL CHIP 330	5% 1/10W
R152	1-216-037-00	METAL CHIP 330	5% 1/10W
R153	1-216-082-00	RES,CHIP 24K	5% 1/10W
R154	1-216-065-91	RES,CHIP 4.7K	5% 1/10W
R156	1-216-085-00	METAL CHIP 33K	5% 1/10W
R157	1-216-069-00	METAL CHIP 6.8K	5% 1/10W
R158	1-216-001-00	METAL CHIP 10	5% 1/10W
		< VARIABLE RESISTOR >	
RV101	1-223-587-11	RES, ADJ, CARBON 22K	
RV102	1-223-587-11	RES, ADJ, CARBON 22K	
RV103	1-223-587-11	RES, ADJ, CARBON 22K	
		< SWITCH >	
S101	1-572-085-11	SWITCH, LEAF (LIMIT)	
		< VIBRATOR >	
X101	1-579-280-11	VIBRATOR, CRYSTAL (16.9344MHz)	
*****			
*	A-4419-064-A	CHEMI-CON BOARD, COMPLETE	*****
		< CAPACITOR >	
C503	1-126-948-11	ELECT 100uF	20% 35V
C551	1-128-131-11	ELECT 22uF	20% 50V
C553	1-126-933-11	ELECT 100uF	20% 16V
C554	1-164-159-11	CERAMIC 0.1uF	50V
C555	1-163-038-91	CERAMIC CHIP 0.1uF	25V
C556	1-126-948-11	ELECT 100uF	20% 35V
C971	1-126-042-11	ELECT 3300uF	20% 35V
C972	1-126-042-11	ELECT 3300uF	20% 35V
C975	1-136-165-00	FILM 0.1uF	5% 50V
C976	1-136-165-00	FILM 0.1uF	5% 50V
		< CONNECTOR >	
* CN501	1-770-729-11	CONNECTOR, BOARD TO BOARD 10P	
* CN551	1-564-506-11	PLUG, CONNECTOR 3P	
		< DIODE >	
D553	8-719-933-47	DIODE HZS7B2L	
D554	8-719-933-39	DIODE HZS6C1L	
D971	8-719-062-40	DIODE D4SBL20UF3	
D972	8-719-024-99	DIODE 11ES2-NTA2B	
		< TRANSISTOR >	
Q505	8-729-900-53	TRANSISTOR DTC114EK	
Q551	8-729-620-05	TRANSISTOR 2SC2603-EF	
Q552	8-729-620-05	TRANSISTOR 2SC2603-EF	
Q553	8-729-026-68	TRANSISTOR 2SD2525(TP)	

**CHEMI-CON**

**CONNECTOR**

**HP**

**LOADING**

Ref. No.	Part No.	Description	Remark
		< RESISTOR >	
R505	1-216-097-91	RES,CHIP 100K 5%	1/10W
R506	1-216-085-00	METAL CHIP 33K 5%	1/10W
R551	1-216-049-91	RES,CHIP 1K 5%	1/10W
R552	1-216-097-91	RES,CHIP 100K 5%	1/10W
R553	1-247-887-00	CARBON 220K 5%	1/4W
R554	1-216-065-91	RES,CHIP 4.7K 5%	1/10W
R821	1-260-089-11	CARBON 150 5%	1/2W
R822	1-260-089-11	CARBON 150 5%	1/2W
R871	1-260-089-11	CARBON 150 5%	1/2W
R872	1-260-089-11	CARBON 150 5%	1/2W
*****			
*	1-671-614-11	CONNECTOR BOARD	
		*****	
		< CAPACITOR >	
C311	1-126-933-11	ELECT 100uF 20%	16V
C312	1-164-159-11	CERAMIC 0.1uF	50V
C501	1-126-933-11	ELECT 100uF 20%	16V
C502	1-126-948-11	ELECT 100uF 20%	35V
C781	1-164-159-11	CERAMIC 0.1uF	50V
C782	1-164-159-11	CERAMIC 0.1uF	50V
C785	1-164-159-11	CERAMIC 0.1uF	50V
C811	1-164-159-11	CERAMIC 0.1uF	50V (AEP,UK)
C812	1-164-159-11	CERAMIC 0.1uF	50V (AEP,UK)
C813	1-164-159-11	CERAMIC 0.1uF	50V (AEP,UK)
C861	1-164-159-11	CERAMIC 0.1uF	50V (AEP,UK)
C862	1-164-159-11	CERAMIC 0.1uF	50V (AEP,UK)
C863	1-164-159-11	CERAMIC 0.1uF	50V (AEP,UK)
		< CONNECTOR >	
* CN781	1-566-856-11	SOCKET, CONNECTOR 5P	
CN811	1-766-921-11	CONNECTOR, BOARD TO BOARD 10P	
* CN961	1-774-813-11	CONNECTOR, BOARD TO BOARD 7P	
CN962	1-695-342-31	PIN, CONNECTOR (PC BOARD) 19P	
		< DIODE >	
D501	8-719-911-19	DIODE 1SS119-25	
D556	8-719-911-19	DIODE 1SS119-25	
D557	8-719-911-19	DIODE 1SS119-25	
D881	8-719-911-19	DIODE 1SS119-25	
		< FERRITE BEAD >	
FB782	1-412-473-21	INDUCTOR 0UH	
		< IC >	
IC311	8-749-923-04	IC TOTX178 (DIGITAL OPTICAL CD AUX)	
		< COIL >	
L311	1-410-322-11	INDUCTOR 3.3uH	
L801	1-420-872-00	COIL, AIR-CORE	

Ref. No.	Part No.	Description	Remark
L861	1-420-872-00	COIL, AIR-CORE	
		< TRANSISTOR >	
Q501	8-729-029-66	TRANSISTOR DTC114ESA	
Q502	8-729-620-05	TRANSISTOR 2SC2603-EF	
Q503	8-729-620-05	TRANSISTOR 2SC2603-EF	
Q504	8-729-620-05	TRANSISTOR 2SC2603-EF	
		< RESISTOR >	
R501	1-247-887-00	CARBON 220K 5%	1/4W
R502	1-249-389-11	CARBON 4.7 5%	1/4W F
R503	1-249-438-11	CARBON 56K 5%	1/4W
△ R504	1-219-122-91	FUSIBLE 0.33 5%	1/4W F
R556	1-249-441-11	CARBON 100K 5%	1/4W
R557	1-249-441-11	CARBON 100K 5%	1/4W
R806	1-249-389-11	CARBON 4.7 5%	1/4W F (AEP,UK)
R809	1-249-437-11	CARBON 47K 5%	1/4W
R811	1-260-076-11	CARBON 10 5%	1/2W
R856	1-249-389-11	CARBON 4.7 5%	1/4W F (AEP,UK)
R859	1-249-438-11	CARBON 56K 5%	1/4W
R861	1-260-076-11	CARBON 10 5%	1/2W
R881	1-249-431-11	CARBON 15K 5%	1/4W
R882	1-249-431-11	CARBON 15K 5%	1/4W
R883	1-249-425-11	CARBON 4.7K 5%	1/4W F
		< RELAY >	
RY501	1-515-920-11	RELAY (24V)	
		< TERMINAL >	
TM811	1-537-842-11	TERMINAL BOARD (SPEAKER)	
*****			
*	1-671-609-11	HP BOARD	
		*****	
		< CAPACITOR >	
C681	1-162-294-31	CERAMIC 0.001uF 10%	50V
C682	1-162-294-31	CERAMIC 0.001uF 10%	50V
C683	1-164-159-11	CERAMIC 0.1uF	50V (AEP,UK)
C684	1-164-159-11	CERAMIC 0.1uF	50V
		< JACK >	
J667	1-774-933-11	JACK (LARGE TYPE)(PHONES)	
*****			
*	1-634-461-11	LOADING BOARD	
		*****	
		< CONNECTOR >	
* CN291	1-564-498-11	PIN, CONNECTOR 5P	
		< SWITCH >	
S291	1-571-924-11	SWITCH, LEAF (LOAD OUT)	
S292	1-571-924-11	SWITCH, LEAF (LOAD IN)	

\*\*\*\*\*

The components identified by mark △ or dotted line with mark △ are critical for safety. Replace only with part number specified.



**MAIN**

Ref. No.	Part No.	Description	Remark	Ref. No.	Part No.	Description	Remark
CN702	1-785-462-11	SOCKET, CONNECTOR (NON-ZIF)11P		L405	1-410-482-31	INDUCTOR 100uH	
CN703	1-770-380-11	CONNECTOR, BOARD TO BOARD 8P				< TRANSISTOR >	
CN704	1-770-380-11	CONNECTOR, BOARD TO BOARD 8P					
CN705	1-695-342-31	PIN, CONNECTOR (PC BOARD) 19P					
		< DIODE >					
D351	8-719-921-40	DIODE MTZJ-4.7C		Q103	8-729-900-53	TRANSISTOR DTC114EK	
D751	8-719-911-19	DIODE 1SS119-25		Q111	8-729-107-46	TRANSISTOR 2SC3624A-L15	
D752	8-719-024-99	DIODE 11ES2-NTA2B		Q112	8-729-107-46	TRANSISTOR 2SC3624A-L15	
D753	8-719-911-19	DIODE 1SS119-25		Q121	8-729-120-28	TRANSISTOR 2SC1623-L5L6	
D755	8-719-911-19	DIODE 1SS119-25		Q141	8-729-107-46	TRANSISTOR 2SC3624A-L15	
D791	8-719-914-42	DIODE DA204K		Q181	8-729-029-21	TRANSISTOR DTA114ESA-TP	
D792	8-719-914-42	DIODE DA204K		Q182	8-729-029-21	TRANSISTOR DTA114ESA-TP	
D793	8-719-914-42	DIODE DA204K		Q183	8-729-029-21	TRANSISTOR DTA114ESA-TP	
		< FERRITE BEAD >		Q211	8-729-107-46	TRANSISTOR 2SC3624A-L15	
FB301	1-412-473-21	INDUCTOR 0UH		Q212	8-729-107-46	TRANSISTOR 2SC3624A-L15	
FB791	1-500-445-21	FERRITE 0UH		Q222	8-729-120-28	TRANSISTOR 2SC1623-L5L6	
FB792	1-500-445-21	FERRITE 0UH		Q241	8-729-107-46	TRANSISTOR 2SC3624A-L15	
		< IC >		Q450	8-729-620-05	TRANSISTOR 2SC2603-EF	
IC101	8-759-494-40	IC M62428AFP600C		Q751	8-729-620-05	TRANSISTOR 2SC2603-EF	
IC102	8-759-300-71	IC HD14053BFP		Q752	8-729-600-22	TRANSISTOR 2SA1235-F	
IC103	8-759-100-96	IC UPC4558G2		Q753	8-729-027-23	TRANSISTOR DTA114EK	
IC351	8-759-822-09	IC LB1641		Q781	8-729-027-23	TRANSISTOR DTA114EK	
IC451	8-759-560-51	IC BU1924F (AEP,UK)		Q782	8-729-107-46	TRANSISTOR 2SC3624A-L15	
IC701	8-759-549-47	IC uPD780018AYGF-015-3BA		Q783	8-729-107-46	TRANSISTOR 2SC3624A-L15	
IC791	8-759-549-80	IC P82B715TD.118		Q791	8-729-025-28	TRANSISTOR 2SK1828	
IC951	8-759-635-63	IC M51943BSL		Q792	8-729-025-28	TRANSISTOR 2SK1828	
		< JACK >				< RESISTOR >	
J101	1-766-396-11	JACK, PIN 4P (MD IN/OUT)		R101	1-216-077-00	METAL CHIP 15K 5%	1/10W
J102	1-779-688-11	JACK, PIN 6P (TAPE,CS/BS IN/OUT)		R102	1-216-073-00	METAL CHIP 10K 5%	1/10W
		< JUMPER RESISTOR >		R103	1-216-033-00	METAL CHIP 220 5%	1/10W
JW301	1-216-295-91	SHORT 0		R104	1-216-049-91	RES,CHIP 1K 5%	1/10W
JW302	1-216-295-91	SHORT 0		R105	1-216-105-91	RES,CHIP 220K 5%	1/10W
JW303	1-216-296-91	SHORT 0		R106	1-216-033-00	METAL CHIP 220 5%	1/10W
JW304	1-216-296-91	SHORT 0		R107	1-216-077-00	METAL CHIP 15K 5%	1/10W
JW412	1-216-295-91	SHORT 0		R108	1-216-073-00	METAL CHIP 10K 5%	1/10W
JW413	1-216-295-91	SHORT 0		R109	1-216-089-91	RES,CHIP 47K 5%	1/10W
JW701	1-216-296-91	SHORT 0		R111	1-216-049-91	RES,CHIP 1K 5%	1/10W
JW734	1-216-295-91	SHORT 0		R112	1-216-065-91	RES,CHIP 4.7K 5%	1/10W
JW735	1-216-295-91	SHORT 0 (SP, HK)		R113	1-216-049-91	RES,CHIP 1K 5%	1/10W
JW791	1-216-295-91	SHORT 0		R114	1-216-065-91	RES,CHIP 4.7K 5%	1/10W
JW792	1-216-296-91	SHORT 0		R115	1-216-097-91	RES,CHIP 100K 5%	1/10W
JW793	1-216-296-91	SHORT 0		R116	1-216-093-91	RES,CHIP 68K 5%	1/10W
JW794	1-216-296-91	SHORT 0		R117	1-216-089-91	RES,CHIP 47K 5%	1/10W
JW795	1-216-295-91	SHORT 0		R123	1-216-055-00	METAL CHIP 1.8K 5%	1/10W
JW796	1-216-296-91	SHORT 0		R124	1-216-069-00	METAL CHIP 6.8K 5%	1/10W
JW797	1-216-296-91	SHORT 0		R125	1-216-104-00	METAL CHIP 200K 5%	1/10W
JW798	1-216-296-91	SHORT 0		R126	1-216-081-00	METAL CHIP 22K 5%	1/10W
		< COIL >		R127	1-216-061-00	METAL CHIP 3.3K 5%	1/10W
L401	1-410-482-31	INDUCTOR 100uH		R128	1-216-081-00	METAL CHIP 22K 5%	1/10W
L402	1-410-482-31	INDUCTOR 100uH		R129	1-216-121-91	RES,CHIP 1M 5%	1/10W
L403	1-410-482-31	INDUCTOR 100uH		R130	1-216-073-00	METAL CHIP 10K 5%	1/10W
L404	1-410-482-31	INDUCTOR 100uH		R139	1-216-121-91	RES,CHIP 1M 5%	1/10W
				R141	1-216-057-00	METAL CHIP 2.2K 5%	1/10W
				R142	1-216-065-91	RES,CHIP 4.7K 5%	1/10W
				R143	1-216-089-91	RES,CHIP 47K 5%	1/10W
				R181	1-247-887-00	CARBON 220K 5%	1/4W
				R183	1-247-887-00	CARBON 220K 5%	1/4W
				R185	1-247-887-00	CARBON 220K 5%	1/4W

Ref. No.	Part No.	Description	Quantity	Power	Remark	Ref. No.	Part No.	Description	Quantity	Power	Remark
R191	1-249-413-11	CARBON	470	5%	1/4W F	R706	1-216-073-00	METAL CHIP	10K	5%	1/10W
R192	1-249-413-11	CARBON	470	5%	1/4W F	R707	1-216-073-00	METAL CHIP	10K	5%	1/10W
R193	1-249-413-11	CARBON	470	5%	1/4W F	R708	1-216-097-91	RES,CHIP	100K	5%	1/10W
R201	1-216-077-00	METAL CHIP	15K	5%	1/10W	R709	1-216-025-91	RES,CHIP	100	5%	1/10W
R202	1-216-073-00	METAL CHIP	10K	5%	1/10W	R710	1-216-025-91	RES,CHIP	100	5%	1/10W
R203	1-216-033-00	METAL CHIP	220	5%	1/10W	R711	1-216-025-91	RES,CHIP	100	5%	1/10W
R204	1-216-049-91	RES,CHIP	1K	5%	1/10W	R712	1-216-025-91	RES,CHIP	100	5%	1/10W
R205	1-216-105-91	RES,CHIP	220K	5%	1/10W	R713	1-216-073-00	METAL CHIP	10K	5%	1/10W
R206	1-216-033-00	METAL CHIP	220	5%	1/10W	R714	1-216-073-00	METAL CHIP	10K	5%	1/10W
R207	1-216-077-00	METAL CHIP	15K	5%	1/10W	R719	1-216-049-91	RES,CHIP	1K	5%	1/10W
R208	1-216-073-00	METAL CHIP	10K	5%	1/10W	R720	1-247-807-31	CARBON	100	5%	1/4W
R211	1-216-049-91	RES,CHIP	1K	5%	1/10W	R721	1-247-807-31	CARBON	100	5%	1/4W
R212	1-216-065-91	RES,CHIP	4.7K	5%	1/10W	R722	1-247-807-31	CARBON	100	5%	1/4W
R213	1-216-049-91	RES,CHIP	1K	5%	1/10W	R723	1-247-807-31	CARBON	100	5%	1/4W
R214	1-216-065-91	RES,CHIP	4.7K	5%	1/10W	R724	1-247-807-31	CARBON	100	5%	1/4W
R215	1-216-097-91	RES,CHIP	100K	5%	1/10W	R725	1-247-807-31	CARBON	100	5%	1/4W
R216	1-216-093-91	RES,CHIP	68K	5%	1/10W	R726	1-247-807-31	CARBON	100	5%	1/4W
R217	1-216-089-91	RES,CHIP	47K	5%	1/10W	R727	1-247-807-31	CARBON	100	5%	1/4W
R223	1-216-055-00	METAL CHIP	1.8K	5%	1/10W	R728	1-216-025-91	RES,CHIP	100	5%	1/10W
R224	1-216-069-00	METAL CHIP	6.8K	5%	1/10W	R730	1-247-807-31	CARBON	100	5%	1/4W
R225	1-216-104-00	METAL CHIP	200K	5%	1/10W	R731	1-247-807-31	CARBON	100	5%	1/4W
R227	1-216-061-00	METAL CHIP	3.3K	5%	1/10W	R732	1-247-807-31	CARBON	100	5%	1/4W
R228	1-216-081-00	METAL CHIP	22K	5%	1/10W	R733	1-247-807-31	CARBON	100	5%	1/4W
R229	1-216-121-91	RES,CHIP	1M	5%	1/10W	R735	1-216-097-91	RES,CHIP	100K	5%	1/10W (AEP,UK)
R230	1-216-073-00	METAL CHIP	10K	5%	1/10W	R734	1-216-097-91	RES,CHIP	100K	5%	1/10W
R241	1-249-421-11	CARBON	2.2K	5%	1/4W F	R736	1-216-097-91	RES,CHIP	100K	5%	1/10W
R242	1-216-065-91	RES,CHIP	4.7K	5%	1/10W	R738	1-247-807-31	CARBON	100	5%	1/4W
R243	1-216-089-91	RES,CHIP	47K	5%	1/10W	R739	1-216-097-91	RES,CHIP	100K	5%	1/10W
R351	1-247-807-31	CARBON	100	5%	1/4W	R740	1-249-417-11	CARBON	1K	5%	1/4W F
R401	1-249-417-11	CARBON	1K	5%	1/4W F	R741	1-216-073-00	METAL CHIP	10K	5%	1/10W
R402	1-249-417-11	CARBON	1K	5%	1/4W F	R751	1-249-417-11	CARBON	1K	5%	1/4W F
R403	1-216-025-91	RES,CHIP	100	5%	1/10W	R752	1-249-425-11	CARBON	4.7K	5%	1/4W F
R404	1-216-025-91	RES,CHIP	100	5%	1/10W	R753	1-249-437-11	CARBON	47K	5%	1/4W
R405	1-216-025-91	RES,CHIP	100	5%	1/10W	R754	1-249-437-11	CARBON	47K	5%	1/4W
R406	1-216-025-91	RES,CHIP	100	5%	1/10W	R755	1-249-429-11	CARBON	10K	5%	1/4W
R407	1-249-405-11	CARBON	100	5%	1/4W F (AEP,UK)	R756	1-216-025-91	RES,CHIP	100	5%	1/10W
R408	1-249-429-11	CARBON	10K	5%	1/4W F (AEP,UK)	R781	1-216-073-00	METAL CHIP	10K	5%	1/10W
R409	1-249-417-11	CARBON	1K	5%	1/4W F (AEP,UK)	R782	1-216-045-00	METAL CHIP	680	5%	1/10W
R410	1-216-073-00	METAL CHIP	10K	5%	1/10W	R783	1-216-045-00	METAL CHIP	680	5%	1/10W
R411	1-216-073-00	METAL CHIP	10K	5%	1/10W	R791	1-216-065-91	RES,CHIP	4.7K	5%	1/10W
△ R451	1-249-401-11	CARBON	47	5%	1/4W F (AEP,UK)	R792	1-216-065-91	RES,CHIP	4.7K	5%	1/10W
R452	1-216-129-00	METAL CHIP	2.2M	5%	1/10W (AEP,UK)	R793	1-216-065-91	RES,CHIP	4.7K	5%	1/10W
R453	1-216-049-91	RES,CHIP	1K	5%	1/10W (AEP,UK)	R794	1-216-065-91	RES,CHIP	4.7K	5%	1/10W
R454	1-249-409-11	CARBON	220	5%	1/4W F (AEP,UK)	< VIBRATOR >					
R455	1-249-409-11	CARBON	220	5%	1/4W F (AEP,UK)	X601	1-579-900-21	VIBRATOR, CRYSTAL (4.332MHz)	(AEP,UK)		
R456	1-249-441-11	CARBON	100K	5%	1/4W	X701	1-579-233-11	VIBRATOR, CERAMIC (5MHz)			
R457	1-249-441-11	CARBON	100K	5%	1/4W	X702	1-567-098-41	VIBRATOR, CRYSTAL (32kHz)			
R701	1-249-425-11	CARBON	4.7K	5%	1/4W F	*****					
R702	1-216-109-00	METAL CHIP	330K	5%	1/10W	*	A-4419-060-A	PANEL BOARD, COMPLETE	*****		
R704	1-216-061-00	METAL CHIP	3.3K	5%	1/10W	< CAPACITOR >					
R705	1-216-061-00	METAL CHIP	3.3K	5%	1/10W	C601	1-163-141-00	CERAMIC CHIP	0.001uF	5%	50V
						C602	1-163-141-00	CERAMIC CHIP	0.001uF	5%	50V
						C603	1-163-141-00	CERAMIC CHIP	0.001uF	5%	50V

The components identified by mark △ or dotted line with mark △ are critical for safety.  
Replace only with part number specified.



**PANEL**

**PANEL-SW**

**REG**

Ref. No.	Part No.	Description	Remark
C604	1-163-141-00	CERAMIC CHIP	0.001uF 5% 50V
C605	1-162-290-31	CERAMIC	470PF 10% 50V
C607	1-163-038-91	CERAMIC CHIP	0.1uF 25V
C608	1-164-159-11	CERAMIC	0.1uF 50V
C609	1-164-159-11	CERAMIC	0.1uF 50V
C610	1-162-215-31	CERAMIC	47PF 5% 50V
C611	1-164-159-11	CERAMIC	0.1uF 50V
C612	1-124-589-11	ELECT	47uF 20% 16V
C613	1-128-131-11	ELECT	22uF 20% 50V
< CONNECTOR >			
* CN601	1-695-374-31	PIN, CONNECTOR (PC BOARD) 13P	
CN603	1-695-372-31	PIN, CONNECTOR (PC BOARD) 11P	
< DIODE >			
D601	8-719-072-76	DIODE SEL5E23C-TP15 (▷▷ / ◁◁)	
D602	8-719-072-76	DIODE SEL5E23C-TP15 ( ◁◁/ ▷▷)	
D603	8-719-072-76	DIODE SEL5E23C-TP15 (□)	
D604	8-719-072-76	DIODE SEL5E23C-TP15 (▷◁◁)	
D605	8-719-058-04	DIODE SEL5223S-TP15 (⊙)	
D606	8-719-056-13	DIODE SML72423C-TP4 (⊕)	
< FLUORESCENT INDICATOR >			
FL601	1-517-805-11	INDICATOR TUBE, FLUORESCENT	
< IC >			
IC601	8-759-572-22	IC MSM9202-02GS-KR1	
IC602	8-759-459-85	IC NJL63H400A	
< TRANSISTOR >			
Q601	8-729-900-53	TRANSISTOR DTC114EK	
< RESISTOR >			
R601	1-216-025-91	RES,CHIP	100 5% 1/10W
R602	1-216-025-91	RES,CHIP	100 5% 1/10W
R603	1-216-025-91	RES,CHIP	100 5% 1/10W
R604	1-216-025-91	RES,CHIP	100 5% 1/10W
R605	1-249-437-11	CARBON	47K 5% 1/4W
R606	1-247-843-11	CARBON	3.3K 5% 1/4W
R607	1-216-029-00	METAL CHIP	150 5% 1/10W
R608	1-216-029-00	METAL CHIP	150 5% 1/10W
R609	1-249-413-11	CARBON	470 5% 1/4W F
R610	1-249-413-11	CARBON	470 5% 1/4W F
R611	1-249-411-11	CARBON	330 5% 1/4W
R612	1-216-029-00	METAL CHIP	150 5% 1/10W
R613	1-216-029-00	METAL CHIP	150 5% 1/10W
R621	1-249-413-11	CARBON	470 5% 1/4W F
R622	1-249-415-11	CARBON	680 5% 1/4W F
R623	1-249-417-11	CARBON	1K 5% 1/4W F
R624	1-249-419-11	CARBON	1.5K 5% 1/4W F
R631	1-249-413-11	CARBON	470 5% 1/4W F
R632	1-249-415-11	CARBON	680 5% 1/4W F
R633	1-249-417-11	CARBON	1K 5% 1/4W F
< SWITCH >			
S621	1-762-875-21	SWITCH, KEYBOARD (⊕)	

Ref. No.	Part No.	Description	Remark
S622	1-762-875-21	SWITCH, KEYBOARD (▷▷ / ◁◁, TUNING +)	
S623	1-762-875-21	SWITCH, KEYBOARD ( ◁◁/ ▷▷, TUNING -)	
S624	1-762-875-21	SWITCH, KEYBOARD (□)	
S625	1-762-875-21	SWITCH, KEYBOARD (▷◁◁)	
S631	1-762-875-21	SWITCH, KEYBOARD (I/⊕)	
S632	1-762-875-21	SWITCH, KEYBOARD (DISPLAY)	
S633	1-762-875-21	SWITCH, KEYBOARD (FUNCTION)	
S634	1-762-875-21	SWITCH, KEYBOARD (TUNER/BAND)	
*****			
* 1-671-617-11	PANEL-SW BOARD *****		
< SWITCH >			
S699	1-771-516-11	SWITCH, PUSH(DETECTION)(1 KEY)	
*****			
* A-4419-068-A	REG BOARD, COMPLETE *****		
< FUSE >			
△ F941	1-532-465-31	FUSE (T3.15AL/250V)	
△ F942	1-532-465-31	FUSE (T3.15AL/250V)	
< CAPACITOR >			
C921	1-126-767-11	ELECT	1000uF 20% 16V
C922	1-164-159-11	CERAMIC	0.1uF 50V
C923	1-126-964-11	ELECT	10uF 20% 50V
C924	1-164-159-11	CERAMIC	0.1uF 50V
C925	1-126-964-11	ELECT	10uF 20% 50V
C941	1-126-934-11	ELECT	220uF 20% 16V
C942	1-126-933-11	ELECT	100uF 20% 16V
C943	1-164-159-11	CERAMIC	0.1uF 50V
C944	1-126-933-11	ELECT	100uF 20% 16V
C945	1-124-995-11	ELECT	220uF 20% 10V
C946	1-126-934-11	ELECT	220uF 20% 16V
C947	1-124-995-11	ELECT	220uF 20% 10V
C948	1-164-159-11	CERAMIC	0.1uF 50V
C949	1-164-159-11	CERAMIC	0.1uF 50V
C951	1-126-940-11	ELECT	330uF 20% 25V
C952	1-126-967-11	ELECT	47uF 20% 50V
C953	1-164-159-11	CERAMIC	0.1uF 50V
C954	1-162-306-11	CERAMIC	0.01uF 20% 16V
< CONNECTOR >			
* CN942	1-564-522-11	PLUG, CONNECTOR 7P	
CN943	1-770-405-11	CONNECTOR, BOARD TO BOARD 8P	
CN944	1-770-405-11	CONNECTOR, BOARD TO BOARD 8P	
CN945	1-506-481-11	PIN, CONNECTOR 2P	
< DIODE >			
D921	8-719-210-21	DIODE 11EQS04	
D922	8-719-210-21	DIODE 11EQS04	
D941	8-719-210-21	DIODE 11EQS04	
D942	8-719-210-21	DIODE 11EQS04	
D943	8-719-210-21	DIODE 11EQS04	
D944	8-719-210-21	DIODE 11EQS04	

The components identified by mark △ or dotted line with mark △ are critical for safety. Replace only with part number specified.

**REG**

**SUB-TRANS**

**TRANS**

Ref. No.	Part No.	Description	Remark	Ref. No.	Part No.	Description	Remark
D945	8-719-986-04	DIODE HZS9A1LTA		D962	8-719-024-99	DIODE 11ES2-NTA2B	
D946	8-719-986-04	DIODE HZS9A1LTA		D963	8-719-024-99	DIODE 11ES2-NTA2B	
D952	8-719-986-26	DIODE HZS12A3LTA		D964	8-719-024-99	DIODE 11ES2-NTA2B	
		< GROUND TERMINAL >					
EPT941	1-537-770-21	TERMINAL BOARD, GROUND		D965	8-719-986-67	DIODE HZS33-2LTA	
		< FUSE HOLDER >		D966	8-719-921-37	DIODE MTZJ-4.7	
						< IC >	
FH941	1-533-293-11	FUSE HOLDER		IC901	8-759-373-79	IC TA7805SB	
FH942	1-533-293-11	FUSE HOLDER				< TRANSISTOR >	
FH943	1-533-293-11	FUSE HOLDER					
FH944	1-533-293-11	FUSE HOLDER		Q901	8-729-029-66	TRANSISTOR DTC114ESA	
		< IC >		Q961	8-729-118-01	TRANSISTOR 2SB1116-K	
IC921	8-759-231-53	IC TA7805S		Q962	8-729-040-19	TRANSISTOR RT1N137L-TP	
IC922	8-759-373-82	IC TA7807SB		Q963	8-729-040-19	TRANSISTOR RT1N137L-TP	
		< TRANSISTOR >		Q964	8-729-040-19	TRANSISTOR RT1N137L-TP	
						< RESISTOR >	
Q941	8-729-140-96	TRANSISTOR 2SD774-34		R901	1-249-429-11	CARBON 10K 5% 1/4W	
Q942	8-729-040-20	TRANSISTOR RT1P137L-TP		△ R961	1-217-637-00	FUSIBLE 1 5% 1/4W F	
Q943	8-729-029-66	TRANSISTOR DTC114ESA		R962	1-249-429-11	CARBON 10K 5% 1/4W	
Q951	8-729-202-67	TRANSISTOR 2SK246-GR3		R964	1-249-429-11	CARBON 10K 5% 1/4W	
Q952	8-729-026-68	TRANSISTOR 2SD2525(TP)		R965	1-247-807-31	CARBON 100 5% 1/4W	
		< RESISTOR >					
R925	1-249-411-11	CARBON 330 5% 1/4W		R966	1-247-807-31	CARBON 100 5% 1/4W	
R941	1-247-843-11	CARBON 3.3K 5% 1/4W		R967	1-247-807-31	CARBON 100 5% 1/4W	
		< THERMISTOR(POSITIVE) >		R968	1-249-428-11	CARBON 8.2K 5% 1/4W F	
				R969	1-249-441-11	CARBON 100K 5% 1/4W	
THP941	1-801-671-11	THERMISTOR, POSITIVE				< RELAY >	
THP942	1-801-671-11	THERMISTOR, POSITIVE					
*****							
*	A-4419-065-A	SUB-TRANS BOARD, COMPLETE		RY901	1-755-276-11	RELAY, POWER	
		*****				< TRANSFORMER >	
		< CAPACITOR >		△ T901	1-433-476-11	TRANSFORMER, POWER	
				*****			
C901	1-126-935-11	ELECT 470uF 20% 16V		*	1-671-615-11	TRANS BOARD	
C902	1-126-933-11	ELECT 100uF 20% 16V				*****	
C903	1-113-925-11	CERAMIC 0.01uF 20% 250V				< CONNECTOR >	
C904	1-164-159-11	CERAMIC 0.1uF 50V		* CN991	1-580-230-31	PIN, CONNECTOR (PC BOARD) 2P	
C962	1-128-576-11	ELECT 100uF 20% 63V		* CN992	1-568-226-11	PIN, CONNECTOR 2P	
				* CN994	1-564-522-11	PLUG, CONNECTOR 7P	
C963	1-164-159-11	CERAMIC 0.1uF 50V				< FUSE >	
C964	1-126-948-11	ELECT 100uF 20% 35V		△ F991	1-532-465-31	FUSE (T3.15AL/250V)	
		< CONNECTOR >				< DIODE >	
* CN901	1-564-687-11	PIN, CONNECTOR 3P					
CN902	1-779-939-11	CONNECTOR, BOARD TO BOARD 7P		D951	8-719-024-99	DIODE 11ES2-NTA2B	
		< DIODE >		D953	8-719-024-99	DIODE 11ES2-NTA2B	
D901	8-719-210-21	DIODE 11EQS04				< FUSE HOLDER >	
D902	8-719-210-21	DIODE 11EQS04					
D903	8-719-210-21	DIODE 11EQS04					
D904	8-719-210-21	DIODE 11EQS04					
D905	8-719-911-19	DIODE 1SS119-25		FH991	1-533-293-11	FUSE HOLDER	
				FH992	1-533-293-11	FUSE HOLDER	
D906	8-719-911-19	DIODE 1SS119-25					
D961	8-719-024-99	DIODE 11ES2-NTA2B					

The components identified by mark △ or dotted line with mark △ are critical for safety. Replace only with part number specified.

# HCD-SD1

**TRANS**

**VOLUME**

Ref. No.	Part No.	Description	Remark
		< THERMISTOR(POSITIVE) >	
THP944	1-801-726-11	THERMISTOR, POSITIVE	
THP945	1-801-726-11	THERMISTOR, POSITIVE	
*****			
*	1-671-610-11	VOLUME BOARD	
		*****	
		< CAPACITOR >	
C691	1-162-306-11	CERAMIC	0.01uF 20% 16V
C692	1-162-306-11	CERAMIC	0.01uF 20% 16V
		< CONNECTOR >	
* CLP691	1-690-880-31	LEAD (WITH CONNECTOR)	
		< SWITCH >	
S691	1-418-012-11	ENCODER, ROTARY (VOLUME)	
*****			
		MISCELLANEOUS	
		*****	
15	1-769-940-11	WIRE (FLAT TYPE) (11 CORE)	
16	1-769-972-11	WIRE (FLAT TYPE) (13 CORE)	
53	1-790-305-11	WIRE (FLAT TYPE) (19 CORE)	
54	1-693-408-11	TUNER	
△57	1-575-651-91	CORD, POWER	
60	1-773-108-11	WIRE (FLAT TYPE) (19 CORE)(100mm)	
△65	1-770-019-11	ADAPTOR, CONVERSION PLUG 3P (UK,HK)	
△255	8-848-379-31	OPTICAL PICK-UP KSS-213B/S-N	
256	1-769-069-11	WIRE (FLAT TYPE) (16 CORE)	
△CN904	1-526-794-11	OUTLET, AC	
FL601	1-517-805-11	INDICATOR TUBE, FLUORESCENT	
M101	X-4917-523-4	MOTOR ASSY (SPINDLE)	
M102	X-4917-504-1	MOTOR ASSY (SLED)	
M551	1-698-997-21	FAN, D.C.	
M904	A-4660-307-A	MOTOR (L) ASSY	
△T991	1-433-478-11	TRANSFORMER, POWER	
*****			
		*****	
		HARDWARE LIST	
		*****	
#1	7-685-871-01	SCREW +BVTT 3X6 (S)	
#2	7-685-646-79	SCREW +BVTP 3X8 TYPE2 N-S	
#4	7-684-024-04	N 4, TYPE 2	
#5	7-682-562-09	SCREW +B 4X10	
#6	7-624-105-04	STOP RING 2.3, TYPE -E	
#7	7-685-234-19	SCREW +KTP 2.6X8 TYPE2NON-SLIT	
#8	7-621-775-10	SCREW +B 2.6X4	

The components identified by mark △ or dotted line with mark △ are critical for safety. Replace only with part number specified.