

## SILICON N-CHANNEL DUAL GATE MOS-FET

Depletion type field-effect transistor in a plastic X-package with source and substrate interconnected, intended for VHF applications, such as VHF television tuners, FM tuners, with 12 V supply voltage. This MOS-FET tetrode is protected against excessive input voltage surges by integrated back-to-back diodes between gates and source.

### QUICK REFERENCE DATA

Drain-source voltage	$V_{DS}$	max.	20 V
Drain current	$I_D$	max.	40 mA
Total power dissipation up to $T_{amb} = 75\text{ }^\circ\text{C}$	$P_{tot}$	max.	225 mW
Junction temperature	$T_j$	max.	150 $^\circ\text{C}$
Transfer admittance at $f = 1\text{ kHz}$ $I_D = 15\text{ mA}; V_{DS} = 10\text{ V}; +V_{G2-S} = 4\text{ V}$	$ y_{fs} $	typ.	25 mS
Input capacitance at gate 1; $f = 1\text{ MHz}$ $I_D = 15\text{ mA}; V_{DS} = 10\text{ V}; +V_{G2-S} = 4\text{ V}$	$C_{ig1-s}$	typ.	4.0 pF
Feedback capacitance at $f = 1\text{ MHz}$ $I_D = 15\text{ mA}; V_{DS} = 10\text{ V}; +V_{G2-S} = 4\text{ V}$	$C_{rs}$	typ.	30 fF
Noise figure at $G_S = 2\text{ mS}; B_S = B_{S\text{ opt}}$ $I_D = 15\text{ mA}; V_{DS} = 10\text{ V}; +V_{G2-S} = 4\text{ V}; f = 200\text{ MHz}$	F	typ.	1.2 dB

### MECHANICAL DATA

Dimensions in mm

Fig.1 SOT103.

#### Pinning

- 1 = source
- 2 = drain
- 3 = gate 2
- 4 = gate 1

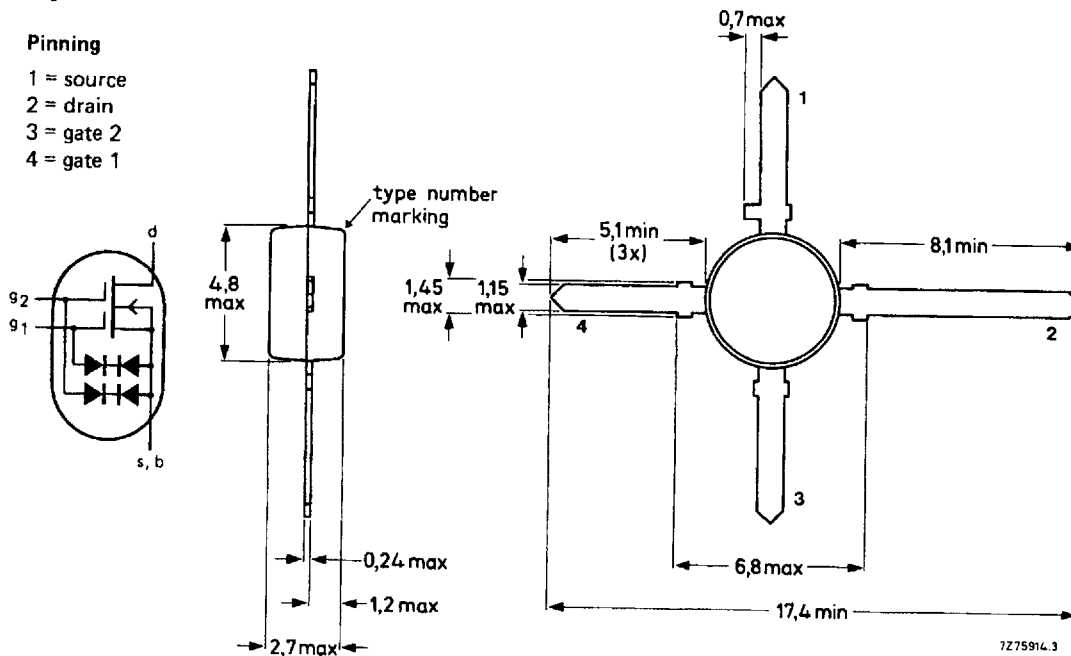

**RATINGS**

Limiting values in accordance with the Absolute Maximum System (IEC 134)

Drain-source voltage	$V_{DS}$	max.	20 V
Drain current (DC or average)	$I_D$	max.	40 mA
Gate 1 - source current	$\pm I_{G1-S}$	max.	10 mA
Gate 2 - source current	$\pm I_{G2-S}$	max.	10 mA
Total power dissipation up to $T_{amb} = 75\text{ }^\circ\text{C}$	$P_{tot}$	max.	225 mW
Storage temperature range	$T_{stg}$	-65 to +150	$^\circ\text{C}$
Junction temperature	$T_j$	max.	150 $^\circ\text{C}$

**THERMAL RESISTANCE**

From junction to ambient in free air  
mounted on the printed-circuit board (see Fig. 2)

$R_{th\ j-a} = 335\text{ K/W}$

Dimensions in mm

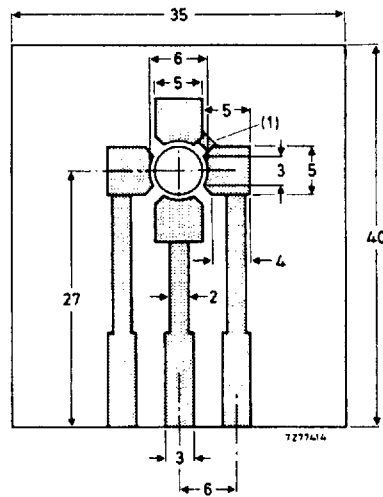

(1) Connection made by a strip or Cu wire.

Fig. 2 Single-sided 35  $\mu\text{m}$  Cu-clad epoxy fibre-glass printed-circuit board, thickness 1,5 mm. Tracks are fully tin-lead plated. Board in horizontal position for  $R_{th}$  measurement.

## STATIC CHARACTERISTICS

 $T_j = 25\text{ }^\circ\text{C}$ 

Gate cut-off currents

$\pm V_{G1-S} = 7\text{ V}; V_{G2-S} = V_{DS} = 0$	$\pm I_{G1-SS}$	<	25 nA
$\pm V_{G2-S} = 7\text{ V}; V_{G1-S} = V_{DS} = 0$	$\pm I_{G2-SS}$	<	25 nA

Gate-source breakdown voltages

$\pm I_{G1-SS} = 10\text{ mA}; V_{G2-S} = V_{DS} = 0$	$\pm V_{(BR)G1-SS}$	>	8 to 20 V
$\pm I_{G2-SS} = 10\text{ mA}; V_{G1-S} = V_{DS} = 0$	$\pm V_{(BR)G2-SS}$	>	8 to 20 V

Gate-source cut-off voltages

$I_D = 20\text{ }\mu\text{A}; V_{DS} = 10\text{ V}; +V_{G2-S} = 4\text{ V}$	$-V_{(P)G1-S}$	<	1.3 V
$I_D = 20\text{ }\mu\text{A}; V_{DS} = 10\text{ V}; V_{G1-S} = 0$	$-V_{(P)G2-S}$	<	1.1 V

## DYNAMIC CHARACTERISTICS

Measuring conditions (common source):  $I_D = 15\text{ mA}; V_{DS} = 10\text{ V}; +V_{G2-S} = 4\text{ V}; T_{amb} = 25\text{ }^\circ\text{C}$ 

Transfer admittance at $f = 1\text{ kHz}$	$ y_{fs} $	>	20 mS
		typ.	25 mS
Input capacitance at gate 1; $f = 1\text{ MHz}$	$C_{ig1-s}$	typ.	4.0 pF
Input capacitance at gate 2; $f = 1\text{ MHz}$	$C_{ig2-s}$	typ.	1.7 pF
Feedback capacitance at $f = 1\text{ MHz}$	$C_{rs}$	typ.	30 fF
Output capacitance at $f = 1\text{ MHz}$	$C_{os}$	typ.	2.0 pF
Noise figure at $f = 200\text{ MHz}; G_S = 2\text{ mS}; B_S = B_S\text{ opt}$	F	typ.	1.2 dB