

LEFT terminal board

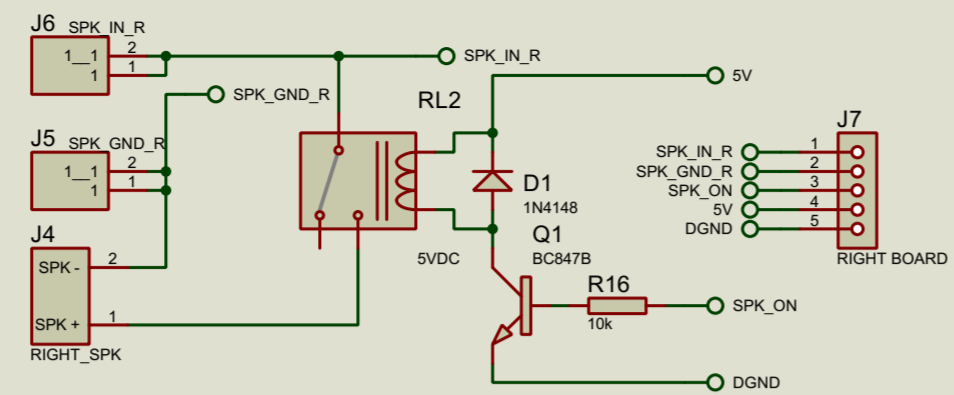

RIGHT terminal board

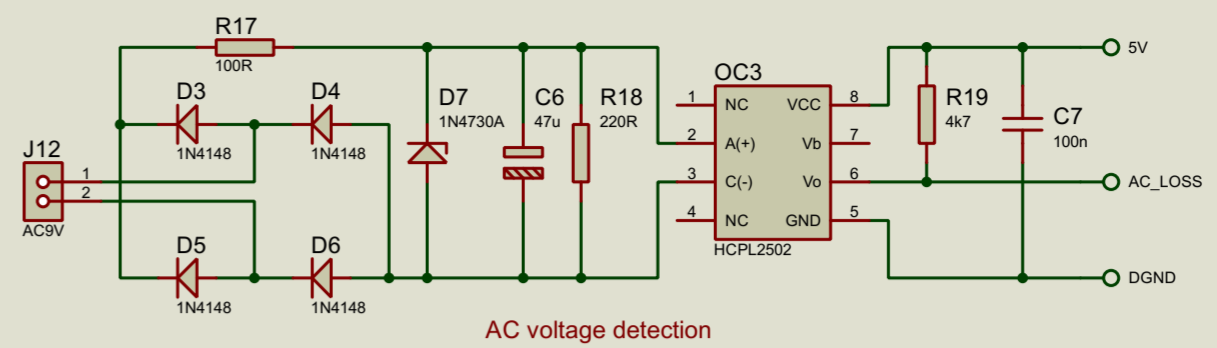

AC voltage detection

HCPL2502 - Positive logic:

LED	V <sub>o</sub>
ON	LOW
OFF	HIGH

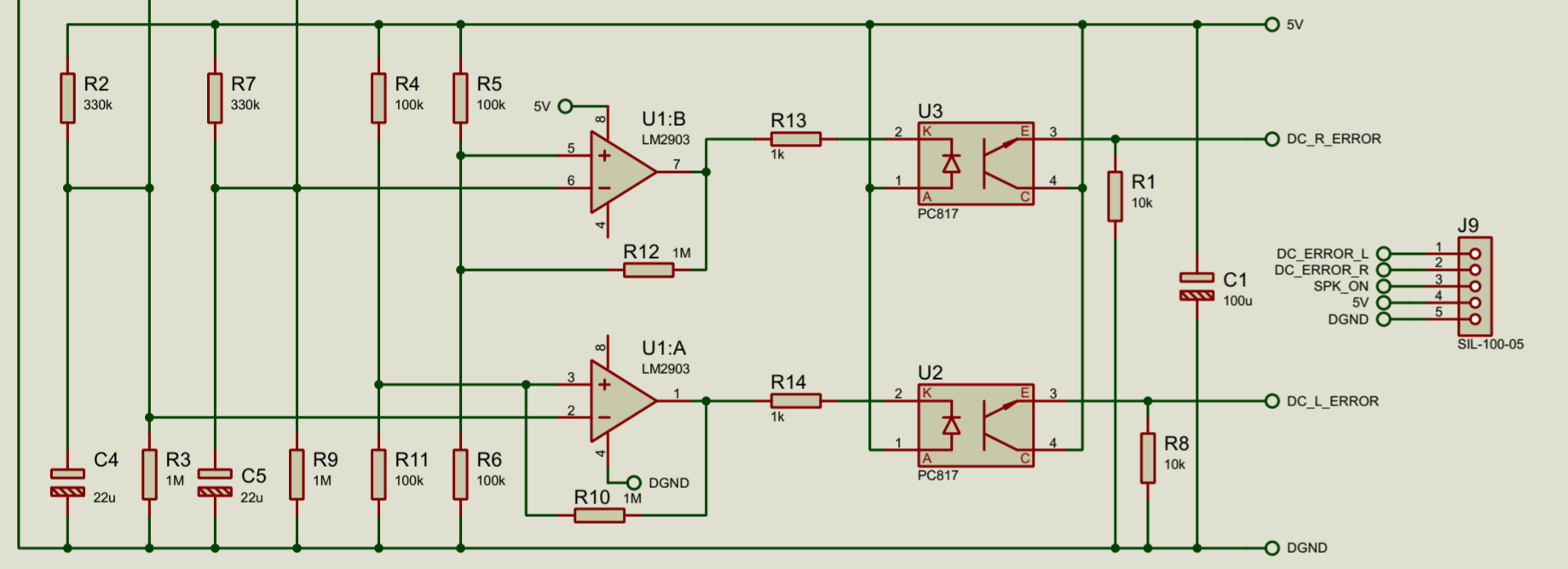
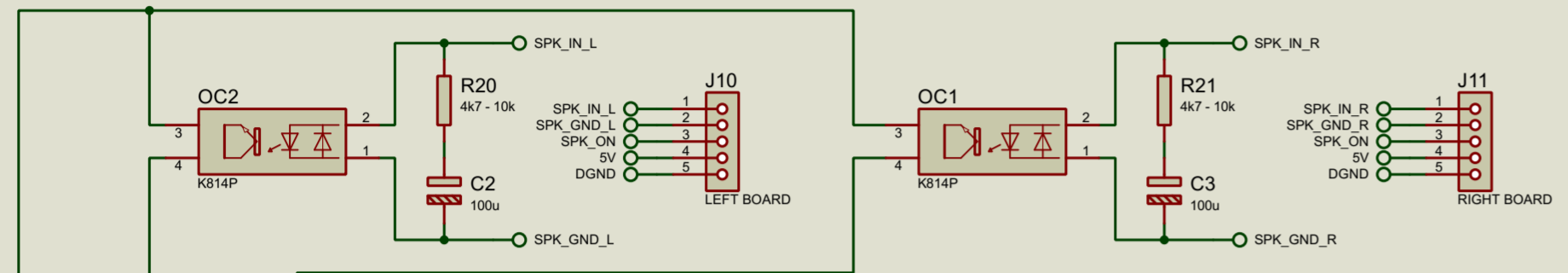

PC817 logic: HIGH on the input lights LED on the output.