

COMSET  
SEMICONDUCTORS

**BDX20**

## PNP SILICON TRANSISTORS EPITAXIAL BASE

LF Large Signal Power Amplification  
High Current Fast Switching  
Thermal Fatigue Inspection

### ABSOLUTE MAXIMUM RATINGS

Symbol	Ratings	Value	Unit
$V_{CBO}$	Collector to Base Voltage	-60	V
$V_{CEO}$	#Collector-Emitter Voltage	-140	V
$V_{CEX}$	Collector-Emitter Voltage $V_{BE}=1.5\text{ V}$	-160	V
$V_{EBO}$	Emitter-Base Voltage	-7	V
$I_C$	Collector Current – Continuous	-10	A
$I_B$	Base Current – Continuous	-7	A
$P_{TOT}$	Total Device Dissipation	117	Watts
$T_J$	Junction Temperature	200	°C
$T_S$	Storage Temperature	-65 to +200	°C

### THERMAL CHARACTERISTICS

Symbol	Ratings	Value	Unit
$R_{thJC}$	Thermal Resistance, Junction to Case	1.5	°C/W

# BDX20

## ELECTRICAL CHARACTERISTICS

TC=25°C unless otherwise noted

Symbol	Ratings	Test Condition(s)	Min	Typ	Mx	Unit
$V_{CE0(SUS)}$	Collector-Emitter Sustaining Voltage (*)	$I_C=-200\text{ mA}, I_B=0$	-140	-	-	V
$V_{CEX}$	Collector-Emitter Breakdown Voltage (*)	$I_C=-100\text{ mA}, V_{BE}=1.5\text{ V}$	-160	-	-	V
$I_{CEX}$	Collector Cutoff Current	$V_{CE}=-140\text{ V}, V_{BE}=1.5\text{ V}$	-	-	-1.0	mA
		$V_{CE}=-140\text{ V}, V_{BE}=1.5\text{ V}, T_{CASE}=150^\circ\text{C}$	-	-	-10	
$I_{CBO}$	Collector-Base Cutoff Current	$V_{CB}=-140\text{ V}, I_E=0$	-	-	-1.0	mA
$I_{EBO}$	Emitter-Base Cutoff Current	$V_{BE}=-7.0\text{ V}, I_C=0$	-	-	-5.0	mA
$h_{21E}$	Static Forward Current Transfer Ratio (*)	$I_C=-3.0\text{ A}, V_{CE}=-4.0\text{ V}$	20	-	70	-
		$I_C=10\text{ A}, V_{CE}=-4.0\text{ V}$	-	10	-	
$V_{CE(SAT)}$	Collector-Emitter Saturation Voltage (*)	$I_C=-3.0\text{ A}, I_B=-0.3\text{ A}$	-	-	-1.0	V
		$I_C=-10\text{ A}, I_B=-2\text{ A}$	-	-	-5.0	
$V_{BE}$	Base-Emitter Voltage (*)	$I_C=-3.0\text{ A}, V_{CE}=-4.0\text{ V}$	-	-1.7	-	V
		$I_C=-10\text{ A}, V_{CE}=-4.0\text{ V}$	-	-5.7	-	
$f_T$	Transition Frequency	$V_{CE}=-10\text{ V}, I_C=-1.0\text{ A}, f=1.0\text{ MHz}$	4	-	-	MHz

In accordance with JEDEC Registration Data

(\*) Pulse Width  $\approx 300\ \mu\text{s}$ , Duty Cycle  $\angle 2.0\%$

## MECHANICAL DATA CASE TO-3

DIMENSIONS		
	mm	inches
A	25,51	1,004
B	38,93	1,53
C	30,12	1,18
D	17,25	0,68
E	10,89	0,43
G	11,62	0,46
H	8,54	0,34
L	1,55	0,6
M	19,47	0,77
N	1	0,04
P	4,06	0,16

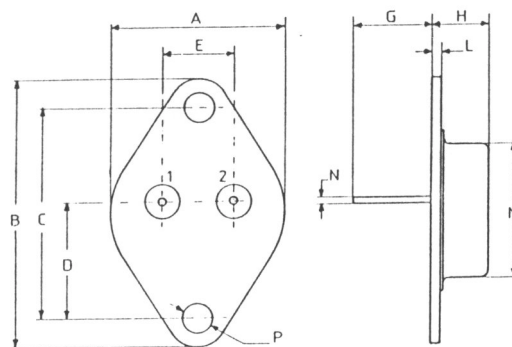

Pin 1 :	Base
Pin 2 :	Collector
Case :	Emitter

This datasheet has been downloaded from:

[www.DatasheetCatalog.com](http://www.DatasheetCatalog.com)

Datasheets for electronic components.