

SERVICE MANUAL

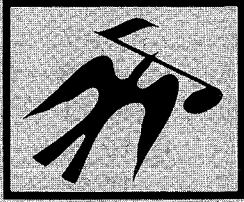

FISHER

CA-30

**Integrated
Stereo Amplifier
(EUROPE)**

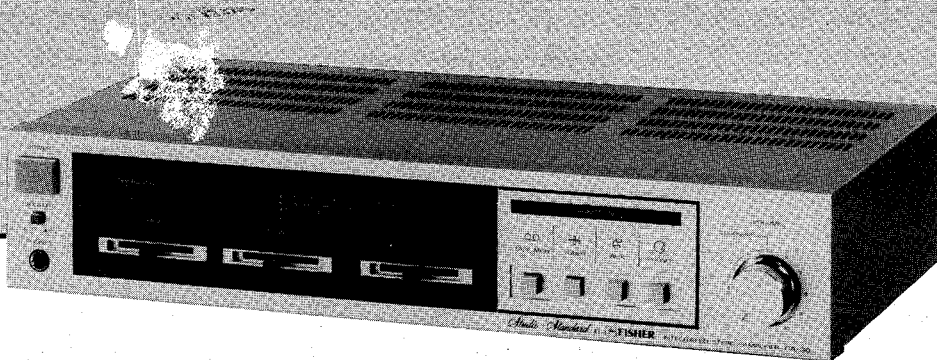

CONTENTS

Functional Block Diagram	2
Specifications	3
Disassembly Instructions	4
Recommended Test Equipments	5
Harmonic Distortion Test	5
Cabinet & Chassis Exploded View	6
Parts List	7
IC Equivalent Circuit & Block Diagram	8
P.C.B. Assy Parts List	9,10,11
Printed Circuit Board (Bottom View)	12,13,14
Point to Point Wiring Diagram	15,16
Schematic Diagram	17,18
Semiconductor Lead Identification	19

FUNCTIONAL BLOCK DIAGRAM

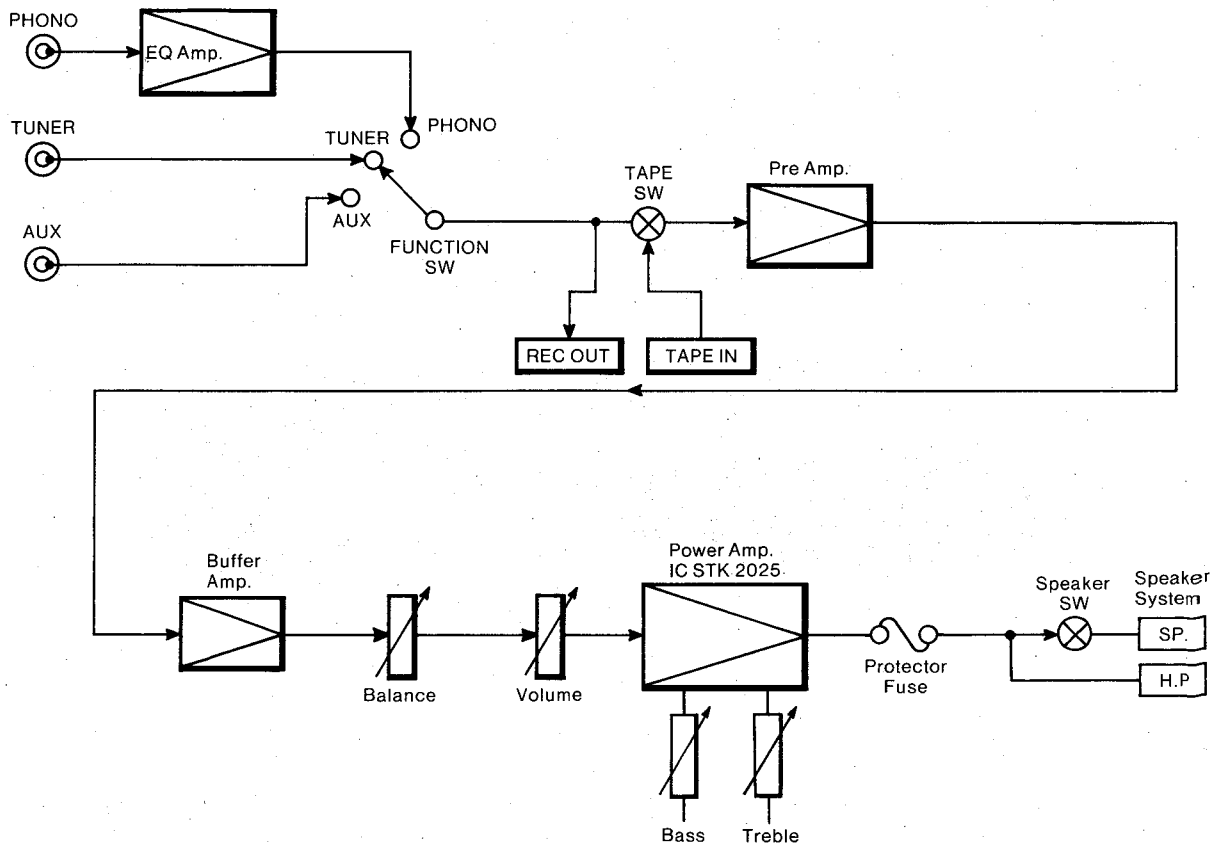

SPECIFICATIONS

AMPLIFIER	CA-30
POWER AMPLIFIER SECTION Minimum RMS sine wave power per channel within stated bandwidth at no more than stated distortion and with 8-ohm load	20 Watts
Power Bandwidth	40 Hz – 20 kHz
Total Harmonic Distortion	0.9 %
I.M. Distortion	0.9 %
Speaker Damping	> 20
PREAMPLIFIER SECTION Frequency Response	
Phono (RIAA)	±0.5 dB
Aux (20 Hz – 20 kHz)	±0.5 dB
Input Sensitivity and Impedance	
Phono	2.5 mV/50 kΩ
Tape Monitor	150 mV/30 kΩ
Tuner/Auxiliary	150 mV/30 kΩ
Phono Max. Input Capability	140 mV
Graphic Equalizer	
50 Hz	±10 dB
250 Hz	±10 dB
1 kHz	±10 dB
4.5 kHz	±10 dB
15 kHz	±10 dB
Hum & Noise (DIN)	
Phono	64 dB
Tape Monitor	85 dB
Tuner/Auxiliary	85 dB
GENERAL	
Power Requirements (50 Hz)	220 V AC
Power Consumption	120 Watts
Power Supply Sockets	2 (FM-30 / CR-30)
Dimensions (W x D x H)	400 x 215 x 80 mm
Weight (approx.)	3.9 kg

Because its products are subject to continuous improvement, Fisher Corporation reserves the right to modify product designs and specifications without notice and without incurring any obligation.

DISASSEMBLY INSTRUCTIONS

A. REMOVAL OF DECORATIVE PANEL

- Detach Cover by removing six screws.
- Pull out VOLUME knob.
- When Decorative Panel is removed from Chassis, the screw tightened through the Top and Bottom can be removed after the screw (A), as shown in Figs. 1 and 2, has been removed.

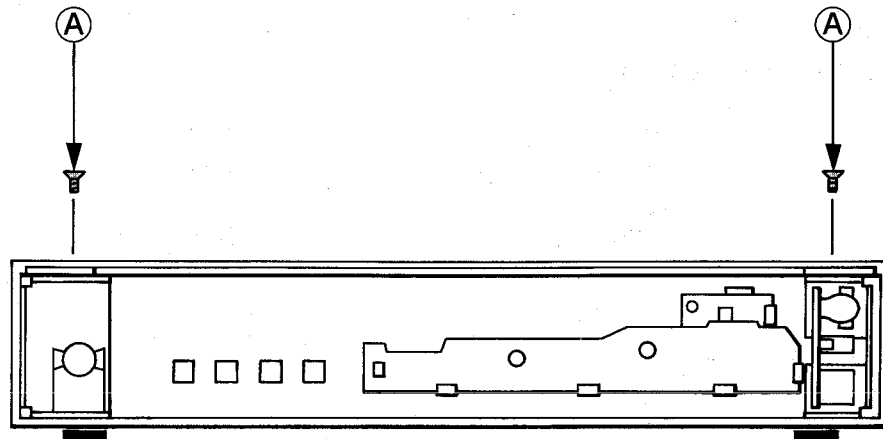

(FRONT PANEL REAR VIEW)

Fig. 1

B. REPAIR AND ADJUSTMENT OF PRINTED CIRCUIT BOARD

- The removal of Cabinet Bottom Plate (B), will give an access to the repair or adjustment work of Printed Circuit Board.

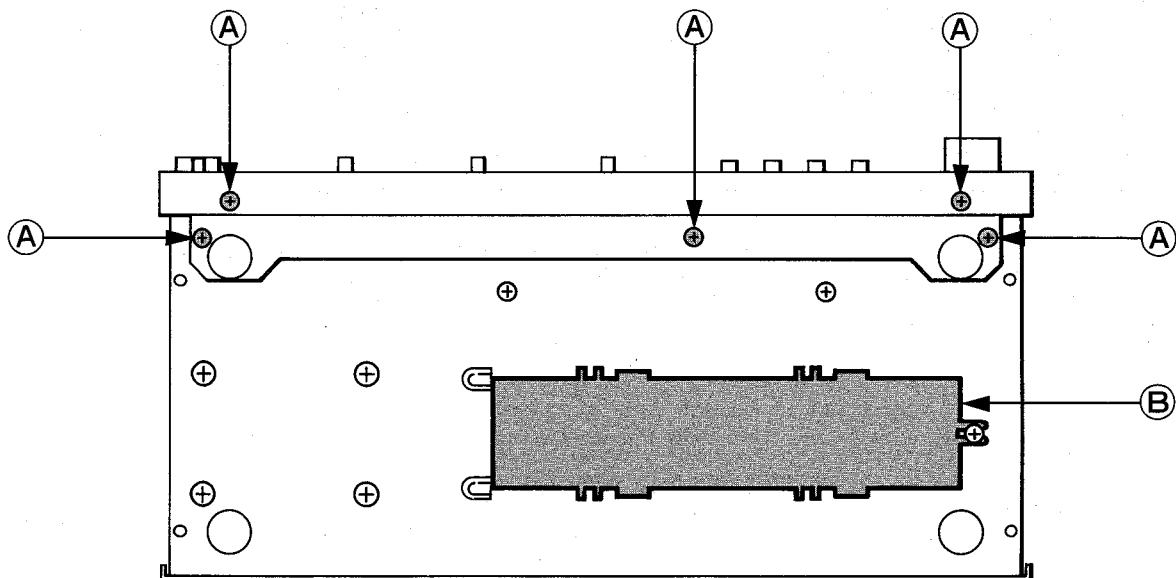

(BOTTOM VIEW)

Fig. 2

RECOMMENDED TEST EQUIPMENTS

The following test equipments are recommended to completely test and align the Amplifier:

- Line Voltage Isolation Transformer
- AC DC Multimeter
- Accurately Calibrated AC Voltmeter
- Oscilloscope (Flat to 100 kHz Minimum)
- Low-Distortion Audio Sine-Wave Generator
- Harmonic Distortion Analyzer
- Two (2) Load Resistors 8-ohms, 250 Watts (Minimum Rating)

HARMONIC DISTORTION TEST

CAUTION: Limit the following tests to no more than ten minutes each. Use 8-ohm resistors, with a minimum power rating of 250 watts when connecting a load across the SPEAKERS terminal.

CONTROL SETTINGS:

Unplug the AC power cord and set the front panel controls as follows:

- BASS / TREBLE controls and BALANCE controls to center positions.
- POWER switch to OFF
- SPEAKERS switch to OFF position
- FUNCTION switch to AUX
- TAPE MONITOR switch to SOURCE
- VOLUME control to MINIMUM position
- LEFT CHANNEL DRIVEN

ONE CHANNEL DRIVEN:

- 1) Connect a low distortion audio generator to LEFT AUX IN jack. Set generator frequency to 1 kHz and output to minimum.
- 2) Connect an 8-ohm load resistor between SPEAKERS SYSTEM-A LEFT and COM terminals. Connect a Harmonic Distortion Analyzer and an AC VTVM in parallel across the 8-ohm load.
- 3) Connect the AC power cord and set SPEAKERS switch to ON position. Turn VOLUME control to MAX.
- 4) Increase generator output for 20 Watts RMS (12.6 volts across the 8-ohm load). Harmonic Distortion Analyzer should measure 0.9 % distortion or less.
- 5) Repeat steps 1 through 4 for RIGHT CHANNEL.

BOTH CHANNELS DRIVEN



Connect 8-ohm load resistors across LEFT and RIGHT SPEAKERS terminals. Adjust generator output and "BALANCE" control for 20 Watts at Left and Right Channels (12.6 volts across the 8-ohm loads). Harmonic Distortion Analyzer should measure 0.9 % distortion or less at each channel.

CAUTION: This precision high-fidelity instrument should be serviced only by qualified personnel, trained in the repair of transistor equipment and printed circuitry.

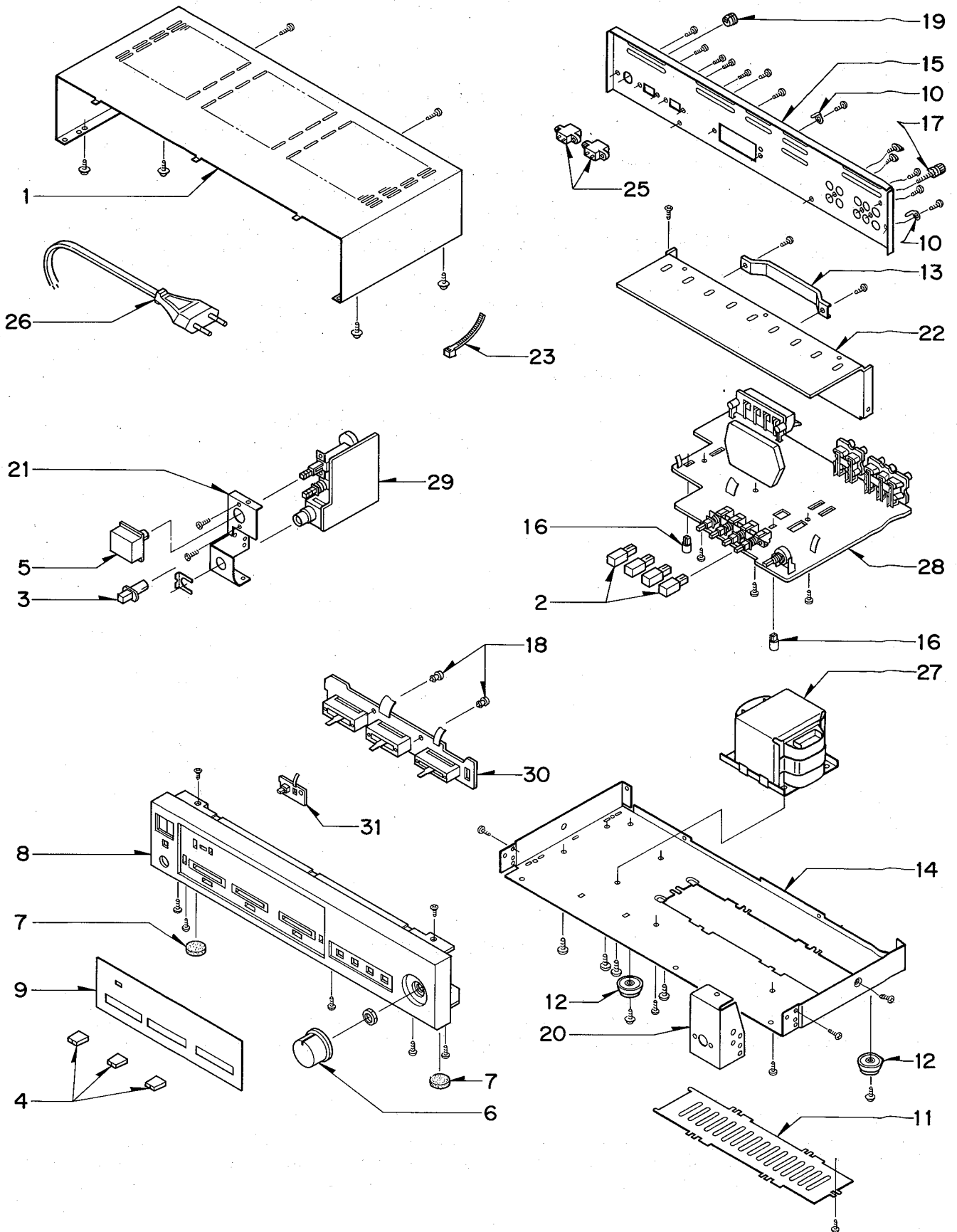
CABINET & CHASSIS EXPLODED VIEW



PARTS LIST

Ref. No.	Part No.	Description	Q'ty	Ref. No.	Part No.	Description	Q'ty
PACKING PARTS LIST				11	131 2 1410 27600	Cover	1
	3 9415 10300	Bag Polyethylene	1	12	131 2 1801 12900	Leg (Rear Panel)	2
131 6	1169 03126	Box Corrugate-EXP	1	13	131 2 3101 71300	Metal Mount IC	1
131 6	2119 02131	Bag Polyethylene-EXP	1	14	131 2 3301 28900	Chassis	1
131 6	3009 33470	Pad	1	15	131 2 3306 37425	Panel Rear	1
131 6	3069 16840	Patching Sheet	1	16	131 2 3614 20300	Mount P.C.B.	2
131 6	4559 10900	Manufacturing No.	2	17	131 2 4201 17800	Screw Ground	1
141 6	1449 88300	Pad (Left)	1	18	131 2 4221 00600	Rivet	2
141 6	1449 88400	Pad (Right)	1	19	131 2 6111 14200	Bushing (Line Cord)	1
ACCESSORIES PARTS LIST				20	141 2 3519 66600	Metal Mount (Right)	1
131 6	2719 10801	Bag Fan	1	21	141 2 3519 66700	Metal Mount (Left)	1
131 6	4519 15700	Guarantee Certificate	1	22	141 2 3689 10900	Plate Heat Sink	1
131 6	4559 10900	Manufacturing No.	1	23	141 2 4729 07100	Wire Band	5
142 6	4119 31868	Explanatory Booklet	1	ELECTRICAL PARTS LIST			
CABINET & CHASSIS PARTS LIST				25	 4 2359 74032	2P Socket With / Nut	2
1	131 2 1410 27401	Cover	1	26	 4 2432 00140	Line Cord	1
2	131 2 1601 64106	Knob (Function Switch)	4	27	 4 2512 22320	Power Trans	1
3	131 2 1601 69602	Knob (Speaker Switch)	1	28	141 0 1939 02300	Main Amplifier P.C.B.Assy	1
4	131 2 1601 71001	Knob (Bass Treble Balance)	3	29	141 0 1939 02310	Power Switch P.C.B.Assy	1
5	131 2 1601 86203	Knob (Power Switch)	1	30	141 0 1939 02320	Tone / Balance P.C.B.Assy	1
6	131 2 1601 87100	Knob (Volume)	1	31	141 0 1939 02330	Power IND. P.C.B.Assy	1
7	131 2 1801 16200	Leg (Front Panel)	2	NOTES:			
8	141 2 1119 98300	Cabinet Front	1	1. Parts order must contain Model Number, Part Number and Description.			
9	141 2 1449 58100	Plate Decorate	1	2. Ordering quantity of screws and resistors must be multiple of 10 pcs.			
10	4 2379 21520	Terminal Lug	2				

PRODUCT SAFETY NOTICE

Each precaution in this manual should be followed during servicing. Components identified with the IEC symbol  in the parts list and the schematic diagram designate components in which safety can be of special significance. When replacing a component identified with , use only the replacement parts designated, or parts with the same ratings of resistance, wattage or voltage that are designated in the parts list in this manual. Leakage-current or resistance measurements must be made to determine that exposed parts are acceptably insulated from the supply circuit before returning the product to the customer.

IC EQUIVALENT CIRCUIT & BLOCK DIAGRAM

EQ AMP IC NJM 072

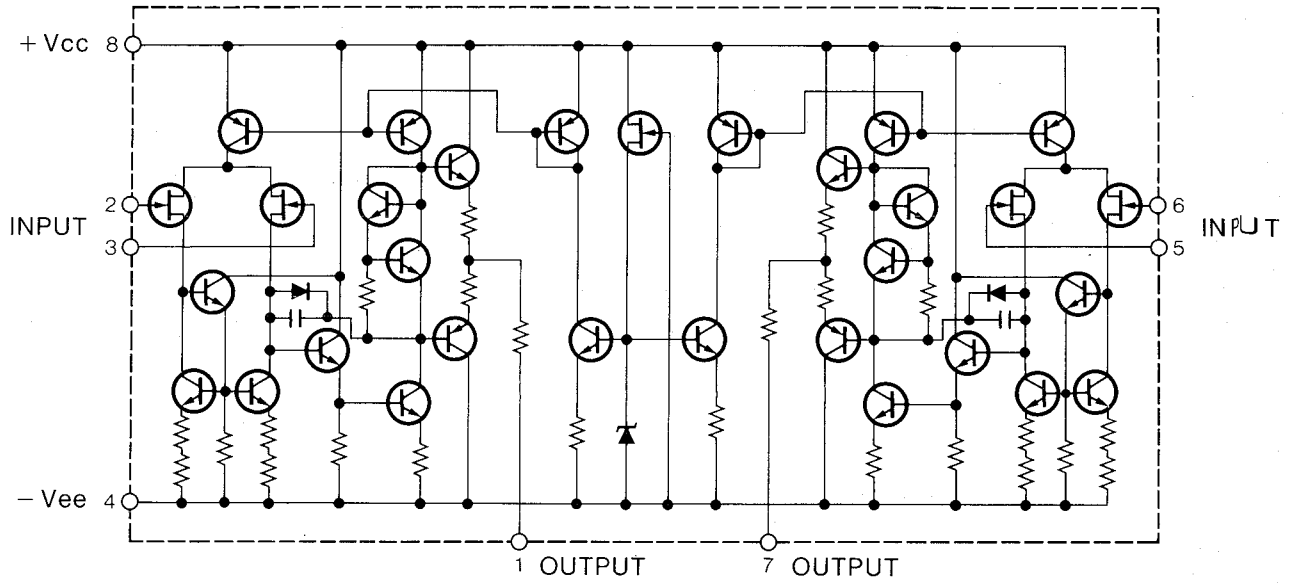

POWER AMP IC STK 2025

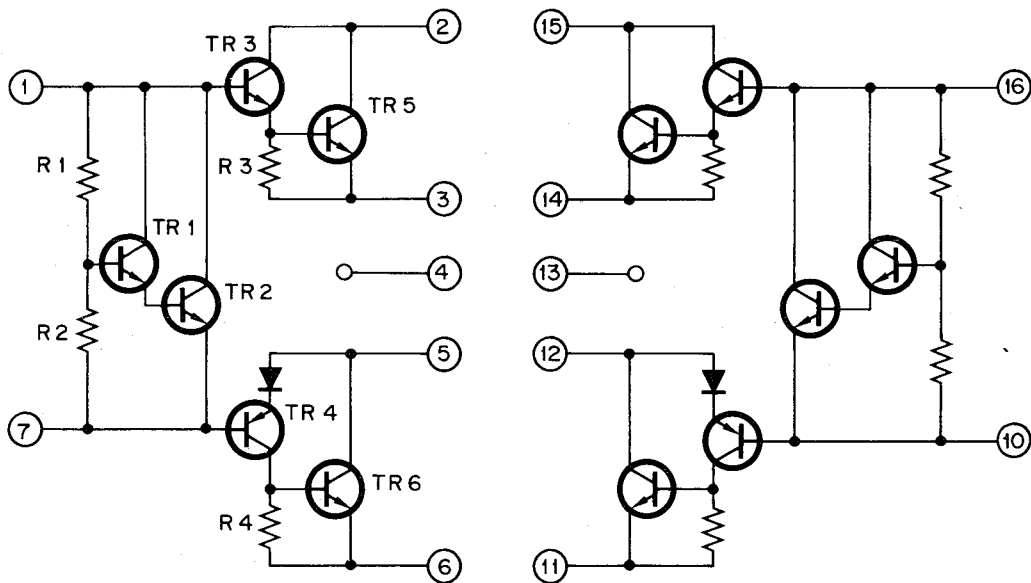

PARTS LIST

Ref. No.	Part No.	Description	Q'ty	Ref. No.	Part No.	Description	Q'ty
MAIN AMPLIFIER P.C.B. Assy				C52	CC2 7 0500 KD00C	Ceramic	27pF 50V ±10%
141	0 1939 02300	Main Amplifier P.C.B. Assy	1	C53	CC0 3 0500 CD00C	Ceramic	3pF 50V ±0.2pF
	4 2319 76300	Switch Push 4 Key	1	C54	CC0 3 0500 CD00C	Ceramic	3pF 50V ±0.2pF
△	4 2349 20570	Fuse T 2.5 A (Speaker Protector)	2	C55	CD1 0 7350 0001V	Electrolytic	100µF 35V
△	4 2349 70260	Fuse T 2.0 A (AC Line)	2	C56	CD1 0 7350 0001V	Electrolytic	100µF 35V
L01	4 2532 00420	RF Filter	1	C57	CD1 0 7100 0001V	Electrolytic	100µF 10V
L02	4 2532 00420	RF Filter	1	C58	CD1 0 7100 0001V	Electrolytic	100µF 10V
VR01	4 2229 74200	VR 100 kΩ -B x 2	1	C59	CM4 7 2500 K00SV	Mylar	0.0047µF 50V ±10%
	4 2352 01700	Pin Jack 4P	1	C60	CM4 7 2500 K00SV	Mylar	0.0047µF 50V ±10%
	4 2352 01780	Pin Jack 6P	1	C61	CD4 7 6250 0001V	Electrolytic	47µF 25V
	4 2352 01940	Fuse Clip	8	C62	CD4 7 6250 0001V	Electrolytic	47µF 25V
	4 2379 70820	4P Push Terminal (Speakers)	1	C63	CD2 2 6250 0001V	Electrolytic	22µF 25V
111	2 6220 11100	Wire Wrap Terminal	3	C64	CD2 2 6250 0001V	Electrolytic	22µF 25V
				C65	CD1 0 6500 0001V	Electrolytic	10µF 50V
				C66	CD1 0 6500 0001V	Electrolytic	10µF 50V
				C67	CD1 0 7350 0001V	Electrolytic	100µF 35V
				C68	CD1 0 7350 0001V	Electrolytic	100µF 35V
				C69	CC4 7 3500 ZG00C	Ceramic	0.047µF 50V ±80.20%
				C70	CC4 7 3500 ZG00C	Ceramic	0.047µF 50V ±80.20%
				C71	CD1 0 6500 0001V	Electrolytic	10µF 50V
				C72	CD1 0 6500 0001V	Electrolytic	10µF 50V
				C73	CD1 0 6500 0001V	Electrolytic	10µF 50V
				C74	CD1 0 6500 0001V	Electrolytic	10µF 50V
				C75	CD1 0 7250 0001V	Electrolytic	100µF 25V
				C76	CD2 2 6250 0001V	Electrolytic	22µF 25V
				C77	CD1 0 6500 0001V	Electrolytic	10µF 50V
				C78	CD1 0 6500 0001V	Electrolytic	10µF 50V
				C79	CD2 2 8350 0005V	Electrolytic	2200µF 35V
				C80	CD2 2 8350 0005V	Electrolytic	2200µF 35V
				C81	CK2 2 4101 K000V	Mylar	0.22µF 100V ±10%
				C82	CK2 2 4101 K000V	Mylar	0.22µF 100V ±10%
				C83	CK2 2 4101 K000V	Mylar	0.22µF 100V ±10%
				C84	CK2 2 4101 K000V	Mylar	0.22µF 100V ±10%
				C85	C14 7 2500 MF00R	Boundary	0.0047µF 50V ±20%
				C86	C14 7 2500 MF00R	Boundary	0.0047µF 50V ±20%
CAPACITORS				SEMICONDUCTORS			
C01	CC4 7 3500 ZG00C	Ceramic	0.047µF 50V ±80.20%	1	D01	205 5 9020 43010	Diode, DS 430
C02	CC4 7 3500 ZG00C	Ceramic	0.047µF 50V ±80.20%	1	D02	205 5 9020 43010	Diode, DS 430
C03	CC2 2 1500 KD00C	Ceramic	220pF 50V ±10%	1	D03	202 5 3210 15012	Zener Diode, GZA 15 Y
C04	CC2 2 1500 KD00C	Ceramic	220pF 50V ±10%	1	D04	202 5 3210 15012	Zener Diode, GZA 15 Y
C05	CC2 2 1500 KD00C	Ceramic	220pF 50V ±10%	1	D05	△ 202 5 2500 13541	Diode, DS 135
C06	CC2 2 1500 KD00C	Ceramic	220pF 50V ±10%	1	D06	△ 202 5 2500 13541	Diode, DS 135
C07	CC2 2 1500 KD00C	Ceramic	220pF 50V ±10%	1	D07	△ 202 5 2500 13541	Diode, DS 135
C08	CC2 2 1500 KD00C	Ceramic	220pF 50V ±10%	1	D08	△ 202 5 2500 13541	Diode, DS 135
C09	CC2 2 1500 KD00C	Ceramic	220pF 50V ±10%	1	D09	202 5 2470 13540	Diode, DS 135 D
C10	CC2 2 1500 KD00C	Ceramic	220pF 50V ±10%	1	D10	205 5 9040 44210	Diode, DS 442
C11	CC2 2 1500 KD00C	Ceramic	220pF 50V ±10%	1	D11	202 5 3210 15012	Zener Diode, GZA 15 Y
C12	CC2 2 1500 KD00C	Ceramic	220pF 50V ±10%	1	D12	202 5 3210 15012	Zener Diode, GZA 15 Y
C13	CC2 2 1500 KD00C	Ceramic	220pF 50V ±10%	1	D13	202 5 3210 20012	Zener Diode, GZA 20 Y
C14	CC2 2 1500 KD00C	Ceramic	220pF 50V ±10%	1	IC01	IJJ - NJM072D-E	IC, NJM 072D E
C15	CD4 7 5250 0001V	Electrolytic	4.7µF 25V	1	IC02	206 5 4302 02510	IC, STK 2025 (Power Amp IC)
C16	CD4 7 5250 0001V	Electrolytic	4.7µF 25V	1	Q01	203 5 5623 06660	Transistor, 2SC 3066 F,G
C17	CD4 7 663A 0001V	Electrolytic	47µF 6.3V	1	Q02	203 5 5623 06660	Transistor, 2SC 3066 F,G
C18	CD4 7 663A 0001V	Electrolytic	47µF 6.3V	1	Q03	203 5 4551 01615	Transistor, 2SA 1016 F,G
C19	CM1 8 3500 K00SV	Mylar	0.018µF 50V ±10%	1	Q04	203 5 4551 01615	Transistor, 2SA 1016 F,G
C20	CM1 8 3500 K00SV	Mylar	0.018µF 50V ±10%	1	Q05	203 5 4921 01260	Transistor, 2SD 1012 F,G
C21	CM4 7 2500 K00SV	Mylar	0.0047µF 50V ±10%	1	Q06	203 5 4921 01260	Transistor, 2SD 1012 F,G
C22	CM4 7 2500 K00SV	Mylar	0.0047µF 50V ±10%	1	Q07	203 5 4921 01260	Transistor, 2SD 1012 F,G
C23	CC2 2 1500 KD00C	Ceramic	220pF 50V ±10%	1	Q08	203 5 4921 01260	Transistor, 2SD 1012 F,G
C24	CC2 2 1500 KD00C	Ceramic	220pF 50V ±10%	1	Q09	203 5 7230 60860	Transistor, 2SA 608 F,G
C25	CC2 2 1500 KD00C	Ceramic	220pF 50V ±10%	1	Q10	203 5 5000 53660	Transistor, 2SC 536 F,G
C26	CC2 2 1500 KD00C	Ceramic	220pF 50V ±10%	1	Q11	203 5 7230 60860	Transistor, 2SA 608 F,G
C27	CD1 0 5500 0001V	Electrolytic	1µF 50V	1	Q12	203 5 7230 60860	Transistor, 2SA 608 F,G
C28	CD1 0 5500 0001V	Electrolytic	1µF 50V	1			
C29	CC2 2 1500 KD00C	Ceramic	220pF 50V ±10%	1			
C30	CC2 2 1500 KD00C	Ceramic	220pF 50V ±10%	1			
C31	CC2 2 1500 KD00C	Ceramic	220pF 50V ±10%	1			
C32	CC2 2 1500 KD00C	Ceramic	220pF 50V ±10%	1			
C33	CC2 2 1500 KD00C	Ceramic	220pF 50V ±10%	1			
C34	CC2 2 1500 KD00C	Ceramic	220pF 50V ±10%	1			
C35	CD1 0 6500 0001V	Electrolytic	10µF 50V	1			
C36	CD1 0 6500 0001V	Electrolytic	10µF 50V	1			
C37	CC4 7 1500 KE00C	Ceramic	470pF 50V ±10%	1			
C38	CC4 7 1500 KE00C	Ceramic	470pF 50V ±10%	1			
C39	CM1 8 3500 K00SV	Mylar	0.018µF 50V ±10%	1			
C40	CM1 8 3500 K00SV	Mylar	0.018µF 50V ±10%	1			
C41	CC1 0 1500 KD00C	Ceramic	100pF 50V ±10%	1			
C42	CC1 0 1500 KD00C	Ceramic	100pF 50V ±10%	1			
C43	CD1 0 5500 0001V	Electrolytic	1µF 50V	1			
C44	CD1 0 5500 0001V	Electrolytic	1µF 50V	1			
C45	CC1 0 1500 JD00R	Ceramic	100pF 50V ±5%	1			
C46	CC1 0 1500 JD00R	Ceramic	100pF 50V ±5%	1			
C47	CC2 2 1500 KD00C	Ceramic	220pF 50V ±10%	1			
C48	CC2 2 1500 KD00C	Ceramic	220pF 50V ±10%	1			
C49	CC2 2 1500 KD00C	Ceramic	220pF 50V ±10%	1			
C50	CC2 2 1500 KD00C	Ceramic	220pF 50V ±10%	1			
C51	CC2 7 0500 KD00C	Ceramic	27pF 50V ±10%	1			

PARTS LIST (Continued)

Ref. No.	Part No.	Description	Q'ty	Ref. No.	Part No.	Description	Q'ty
RESISTORS				R67	RD1 0 2251 JM000	Carbon	1k Ω 1/4W \pm 5% 1
R01	RD2 2 2161 JH000	Carbon	2.2k Ω 1/6W \pm 5% 1	R68	RD2 2 3251 JM000	Carbon	22k Ω 1/4W \pm 5% 1
R02	RD2 2 2161 JH000	Carbon	2.2k Ω 1/6W \pm 5% 1	R69	RH1 2 2501 JZ000	Metal	1.2k Ω 1/2W \pm 5% 1
R03	RD1 0 4161 JH000	Carbon	100k Ω 1/6W \pm 5% 1	R70	RH1 2 2501 JZ000	Metal	1.2k Ω 1/2W \pm 5% 1
R04	RD1 0 4161 JH000	Carbon	100k Ω 1/6W \pm 5% 1	R71	RD5 6 2251 JM000	Carbon	5.6k Ω 1/4W \pm 5% 1
R05	RD1 0 4161 JH000	Carbon	100k Ω 1/6W \pm 5% 1	R72	RD3 3 2251 JM000	Carbon	3.3k Ω 1/4W \pm 5% 1
R06	RD1 0 4161 JH000	Carbon	100k Ω 1/6W \pm 5% 1	R73	RD3 3 2251 JM000	Carbon	3.3k Ω 1/4W \pm 5% 1
R07	RD2 7 1161 JH000	Carbon	270 Ω 1/6W \pm 5% 1				
R08	RD2 7 1161 JH000	Carbon	270 Ω 1/6W \pm 5% 1				
R09	RD2 2 4161 JH000	Carbon	220k Ω 1/6W \pm 5% 1				
R10	RD2 2 4161 JH000	Carbon	220k Ω 1/6W \pm 5% 1				
R11	RD1 5 3161 JH000	Carbon	15k Ω 1/6W \pm 5% 1				
R12	RD1 5 3161 JH000	Carbon	15k Ω 1/6W \pm 5% 1				
R13	RD1 0 4161 JH000	Carbon	100k Ω 1/6W \pm 5% 1				
R14	RD1 0 4161 JH000	Carbon	100k Ω 1/6W \pm 5% 1				
R15	RD2 2 2161 JH000	Carbon	2.2k Ω 1/6W \pm 5% 1				
R16	RD2 2 2161 JH000	Carbon	2.2k Ω 1/6W \pm 5% 1				
R17	RF1 0 1251 JK000	Mold	100 Ω 1/4W \pm 5% 1				
R18	RF1 0 1251 JK000	Mold	100 Ω 1/4W \pm 5% 1				
R19	RD5 6 2161 JH000	Carbon	5.6k Ω 1/6W \pm 5% 1				
R20	RD5 6 2161 JH000	Carbon	5.6k Ω 1/6W \pm 5% 1				
R21	RD1 5 3251 JM000	Carbon	15k Ω 1/4W \pm 5% 1				
R22	RD1 5 3251 JM000	Carbon	15k Ω 1/4W \pm 5% 1				
R23	RD1 0 2251 JM000	Carbon	1k Ω 1/4W \pm 5% 1				
R24	RD1 0 2251 JM000	Carbon	1k Ω 1/4W \pm 5% 1				
R25	RD5 6 3251 JM000	Carbon	56k Ω 1/4W \pm 5% 1				
R26	RD5 6 3251 JM000	Carbon	56k Ω 1/4W \pm 5% 1				
R27	RD5 6 1161 JH000	Carbon	560 Ω 1/6W \pm 5% 1				
R28	RD5 6 1161 JH000	Carbon	560 Ω 1/6W \pm 5% 1				
R29	RD1 0 1251 JM000	Carbon	100 Ω 1/4W \pm 5% 1				
R30	RD1 0 1251 JM000	Carbon	100 Ω 1/4W \pm 5% 1				
R31	RF1 0 1501 KH000	Mold	100 Ω 1/2W \pm 10% 1				
R32	RF1 0 1501 KH000	Mold	100 Ω 1/2W \pm 10% 1				
R33	RD8 2 1251 JM000	Carbon	820 Ω 1/4W \pm 5% 1				
R34	RD8 2 1251 JM000	Carbon	820 Ω 1/4W \pm 5% 1				
R35	RD5 6 3251 JM000	Carbon	56k Ω 1/4W \pm 5% 1				
R36	RD5 6 3251 JM000	Carbon	56k Ω 1/4W \pm 5% 1				
R37	RD3 3 3251 JM000	Carbon	33k Ω 1/4W \pm 5% 1				
R38	RD3 3 3251 JM000	Carbon	33k Ω 1/4W \pm 5% 1				
R39	RD3 3 3251 JM000	Carbon	33k Ω 1/4W \pm 5% 1				
R40	RD3 3 3251 JM000	Carbon	33k Ω 1/4W \pm 5% 1				
R41	RD1 5 3251 JM000	Carbon	15k Ω 1/4W \pm 5% 1				
R42	RD1 5 3251 JM000	Carbon	15k Ω 1/4W \pm 5% 1				
R43	RD2 7 2251 JM000	Carbon	2.7k Ω 1/4W \pm 5% 1				
R44	RD2 7 2251 JM000	Carbon	2.7k Ω 1/4W \pm 5% 1				
R45	RD2 7 2251 JM000	Carbon	2.7k Ω 1/4W \pm 5% 1				
R46	RD2 7 2251 JM000	Carbon	2.7k Ω 1/4W \pm 5% 1				
R47	RD1 8 2251 JM000	Carbon	1.8k Ω 1/4W \pm 5% 1				
R48	RD1 8 2251 JM000	Carbon	1.8k Ω 1/4W \pm 5% 1				
R49	RF1 0 1501 JZ000	Mold	100 Ω 1/2W \pm 5% 1				
R50	RF1 0 1501 JZ000	Mold	100 Ω 1/2W \pm 5% 1				
R51	RH1 0 0102 JZ000	Metal	10 Ω 1W \pm 5% 1				
R52	RH1 0 0102 JZ000	Metal	10 Ω 1W \pm 5% 1				
R53	RD1 0 1251 JM000	Carbon	100 Ω 1/4W \pm 5% 1				
R54	RD1 0 1251 JM000	Carbon	100 Ω 1/4W \pm 5% 1				
R55	RD5 6 1161 JH000	Carbon	560 Ω 1/6W \pm 5% 1				
R56	RD5 6 1161 JH000	Carbon	560 Ω 1/6W \pm 5% 1				
R59	RD3 9 2251 JM000	Carbon	3.9k Ω 1/4W \pm 5% 1				
R60	RD3 9 2251 JM000	Carbon	3.9k Ω 1/4W \pm 5% 1				
R61	RD4 7 2251 JM000	Carbon	4.7k Ω 1/4W \pm 5% 1				
R62	RD4 7 2251 JM000	Carbon	4.7k Ω 1/4W \pm 5% 1				
R64	RD3 3 3251 JM000	Carbon	33k Ω 1/4W \pm 5% 1				
R65	RD3 3 3251 JM000	Carbon	33k Ω 1/4W \pm 5% 1				
R66	RD2 2 3251 JM000	Carbon	22k Ω 1/4W \pm 5% 1				

PARTS LIST (Continued)

Ref. No.	Part No.	Description	Q'ty
POWER SWITCH P.C.B. Assy			
	141 0 1939 02310	Power Switch P.C.B. Assy	1
⚠	4 2312 05710	Switch Push Power	1
	4 2312 05820	Switch Push 1 Key	1
	4 2352 00970	Headphone Jack 3P	1
	4 2372 00830	EC Terminal 1P	2
111 2	6220 11100	Wire Wrap Terminal	2
131 2	6114 01400	Cover Safty	1
CAPACITOR			
C01 ⚠	4 2239 70970	Electrolytic 0.01μF 400V	1
RESISTORS			
R01	RH3 3 1102 JZ000	Metal 330Ω 1W ±5%	1
R02	RH3 3 1102 JZ000	Metal 330Ω 1W ±5%	1
R03	RD2 7 1251 JM000	Carbon 270Ω 1/4W ±5%	1
R04	RD2 7 1251 JM000	Carbon 270Ω 1/4W ±5%	1
STONE / BALANCE P.C.B. Assy			
	141 0 1939 02320	Tone / Balance P.C.B. Assy	1
VR02	4 2229 74640	Slide VR 200 kΩ -Wx1	1
VR03	4 2229 74650	Slide VR 100 kΩ -Cx2	1
VR04	4 2229 74650	Slide VR 100 kΩ -Cx2	1
CAPACITORS			
C01	CM27 3500 K00SV	Mylar 0.027μF 50V ±10%	1
C02	CM27 3500 K00SV	Mylar 0.027μF 50V ±10%	1
C03	CM27 4500 J00TV	Mylar 0.27μF 50V ±5%	1
C04	CM27 4500 J00TV	Mylar 0.27μF 50V ±5%	1
C05	CM33 2500 K00SV	Mylar 0.0033μF 50V ±10%	1
C06	CM33 2500 K00SV	Mylar 0.0033μF 50V ±10%	1
C07	CM33 3500 K00SV	Mylar 0.033μF 50V ±10%	1
C08	CM33 3500 K00SV	Mylar 0.033μF 50V ±10%	1
RESISTORS			
R01	RD1 0 3251 JM000	Carbon 10kΩ 1/4W ±5%	1
R02	RD1 0 3251 JM000	Carbon 10kΩ 1/4W ±5%	1
R03	RD1 2 4161 JH000	Carbon 120kΩ 1/6W ±5%	1
R04	RD1 2 4161 JH000	Carbon 120kΩ 1/6W ±5%	1
R05	RD1 8 2161 JH000	Carbon 1.8kΩ 1/6W ±5%	1
R06	RD1 8 2161 JH000	Carbon 1.8kΩ 1/6W ±5%	1
R07	RD1 2 2161 JH000	Carbon 1.2kΩ 1/6W ±5%	1
R08	RD1 2 2161 JH000	Carbon 1.2kΩ 1/6W ±5%	1
R09	RD4 7 1251 JM000	Carbon 470Ω 1/4W ±5%	1
R10	RD4 7 1161 JH000	Carbon 470Ω 1/6W ±5%	1
R11	RD1 0 2161 JH000	Carbon 1kΩ 1/6W ±5%	1
R12	RD1 0 2161 JH000	Carbon 1kΩ 1/6W ±5%	1

POWER IND. P.C.B. ASSY

141 0	1939 02330	Power IND. P.C.B. Assy	1
131 2	4208 41800	Spacer (L.E.D.)	1

SEMICONDUCTOR

D01	D00 - SLP- 173B-	L.E.D., SLP 173 B 01	1
-----	------------------	----------------------	---

NOTES:

- Parts order must contain Model Number, Part Number and Description.
- Ordering quantity of screws and resistors must be multiple of 10 pcs.

POWER SWITCH P.C.BOARD

(BOTTOM VIEW)

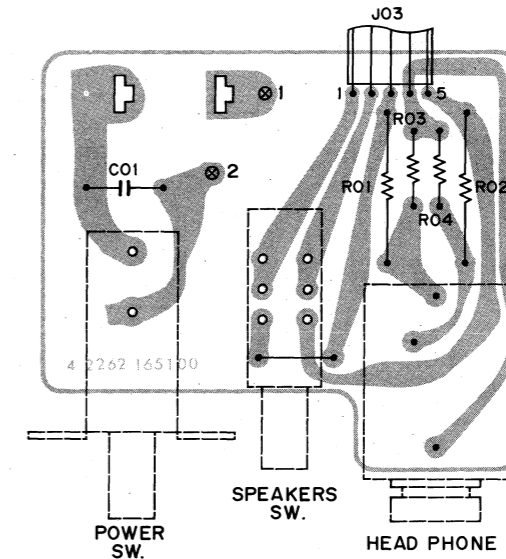

POWER IND. P.C.BOARD

(BOTTOM VIEW)

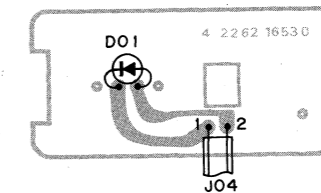

TONE/BALANCE P.C.BOARD

(BOTTOM VIEW)

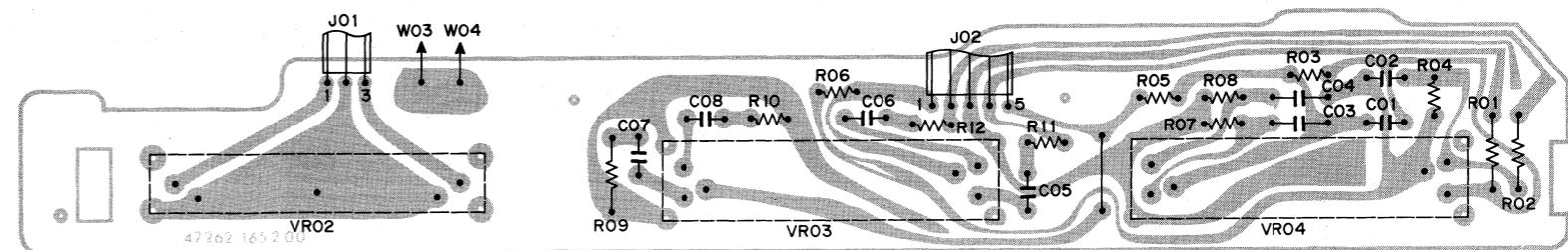

MAIN AMPLIFIER P.C.BOARD

(BOTTOM VIEW)

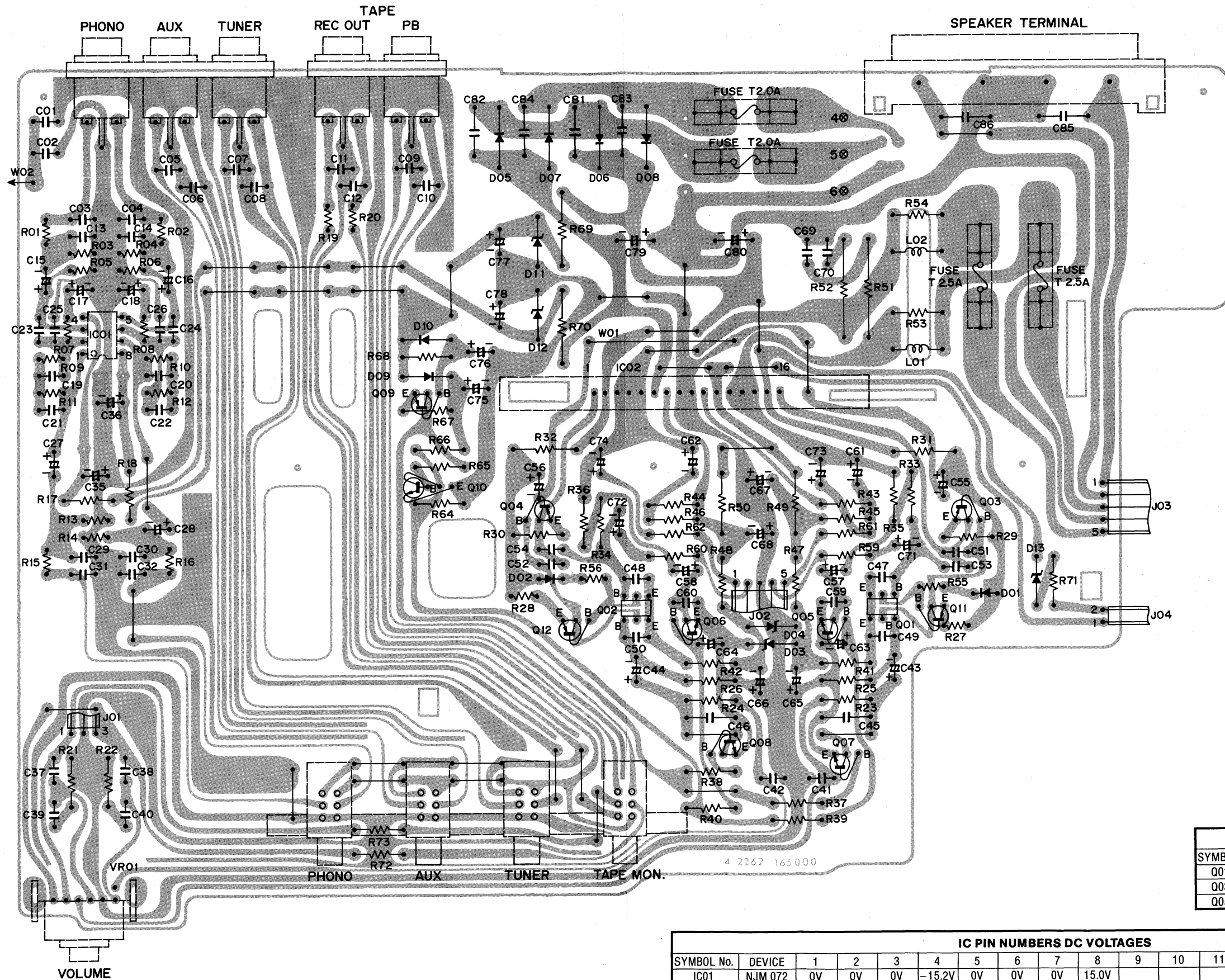

TRANSISTOR DC VOLTAGES				
SYMBOL No.	DEVICE	B	C	E
Q01,02	2SC 3066	-95mV	26.6V	-0.6V
Q03,04	2SA 1016	26.6V	30mV	27.5V
Q05,06	2SD 1012	0.6V	0V	0V

IC PIN NUMBERS DC VOLTAGES																	
SYMBOL No.	DEVICE	1	2	3	4	5	6	7	8	9	10	11	12	13	14	15	16
IC01	NJM 072	0V	0V	0V	-15.2V	0V	0V	0V	15.0V								
IC02	STK 2025	30mV	28.5V	-	-	-	-28.5V	-40mV	-	-	-40mV	-28.5V	-	-	-	28.5V	30mV

POINT TO POINT WIRING DIAGRAM

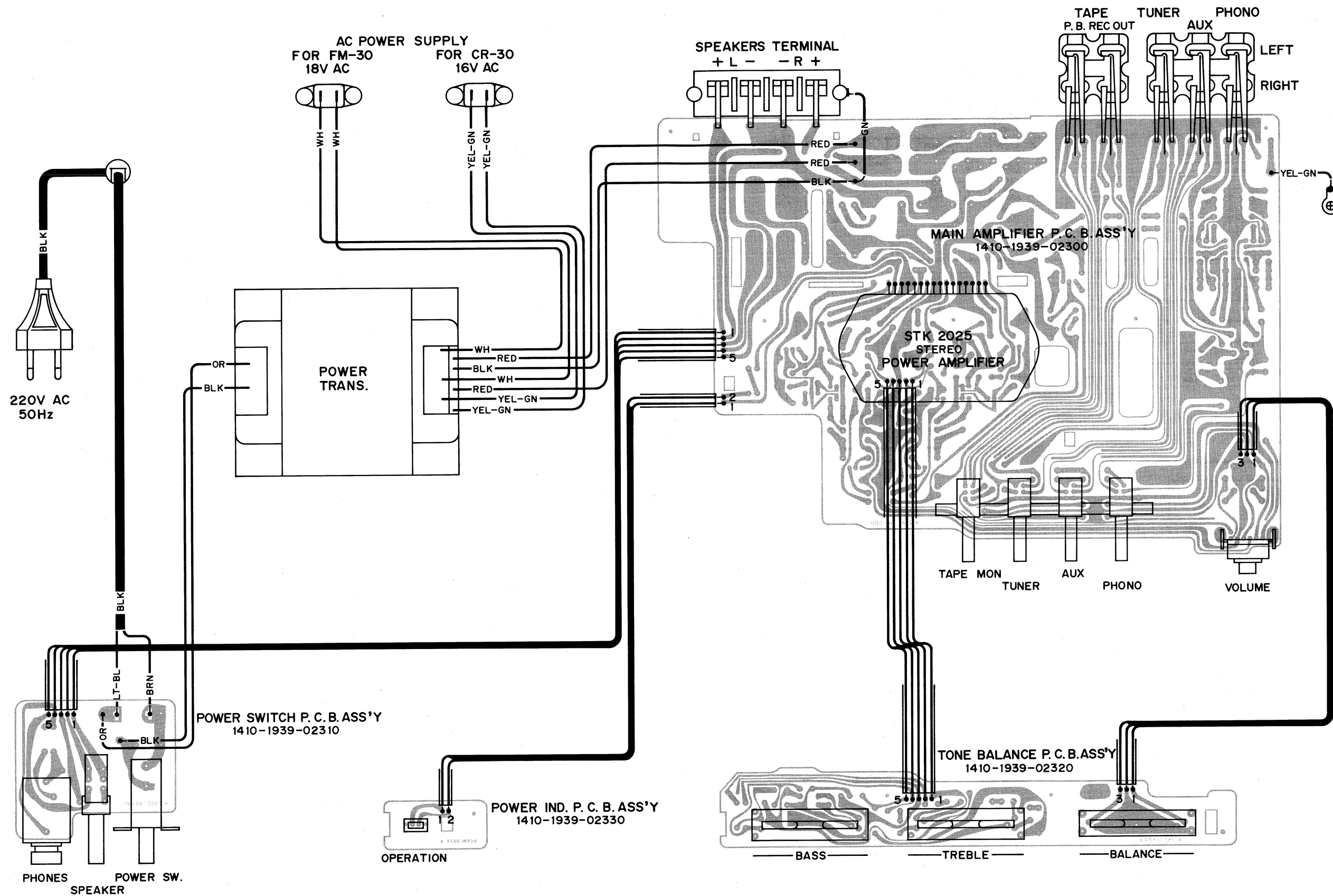

SCHEMATIC DIAGRAM

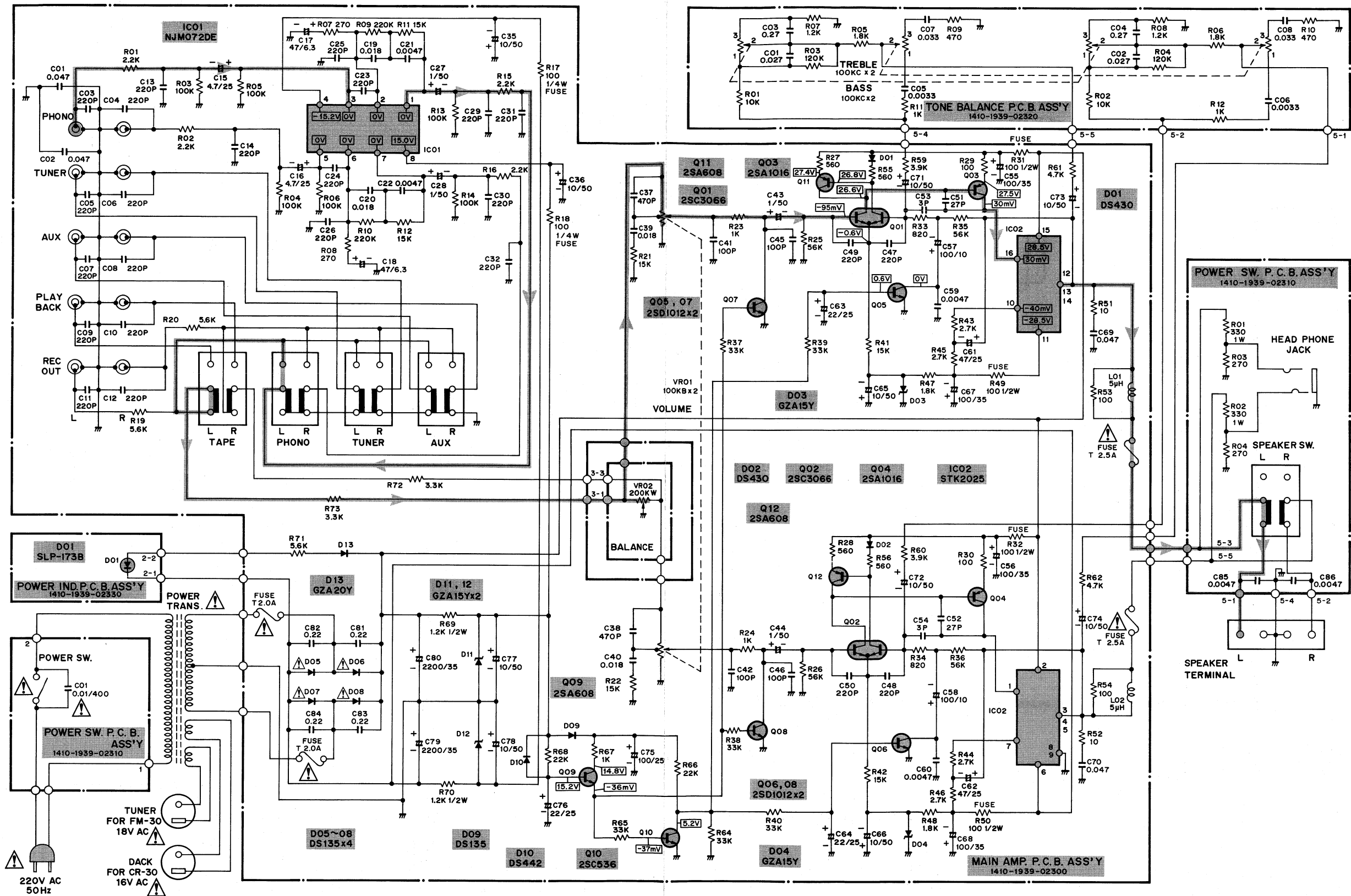

NOTES:

1. All resistors values are indicated in "ohm" (K=10³, M=10⁶).
 2. All capacitors values are indicated in "μF" (P=10⁻¹²).
 3. All voltages indicated on the schematics are measured under the following conditions.
 - a. Use a V.T.V.M.
 - b. All voltages ±10% with respect to chassis ground
 - c. AC input at 220 volts 50 Hz
 - d. FUNCTION SW: AUX
 - e. Input Signal: 1kHz (Sine-wave)
 - f. Load Resistance: 8 Ω
 4. This is a basic schematic diagram.
- Output: 4.785 W +4.785 W (6.2 V)
- Because Fisher products are subject to continuous improvement, Fisher Corporation reserves the right to make any changes or modifications without notice.

PRODUCT SAFETY NOTICE

Each precaution in this manual should be followed during servicing. Components identified with the IEC symbol in the parts list and the schematic diagram designate components in which safety can be of special significance. When replacing a component identified with , use only the replacement parts designated, or parts with the same ratings of resistance, wattage or voltage that are designated in the parts list in this manual. Leakage-current or resistance measurements must be made to determine that exposed parts are acceptably insulated from the supply circuit before returning the product to the customer.

SEMICONDUCTOR LEAD IDENTIFICATION

INTEGRATED CIRCUITS

DC AMP IC

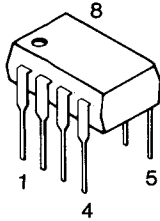

- NJM 072

POWER AMPLIFIER IC

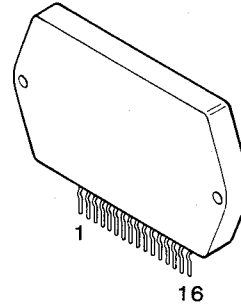

- STK 2025

TRANSISTORS



- 2SD 1012



- 2SC 536
- 2SA 1016
- 2SA 608

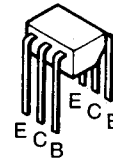

- 2SC 3066

DIODES

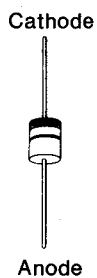

- DS 135 D

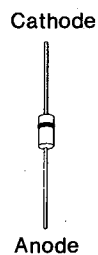

- DS 442
- GZA 15 Y
- GZA 20 Y

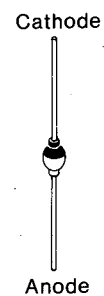

- DS 430