

# TC-K620/K650ES

## SERVICE MANUAL

*US Model*  
*Canadian Model*  
*AEP Model*  
 TC-K620  
*US Model*  
*UK Model*  
*E Model*  
 TC-K650ES



Photo: TC-K650ES

### SPECIFICATIONS

Recording system 4-track 2-channel stereo  
 Bias AC bias  
 Heads Erase head × 1 (S & F head)  
 Recording head × 1 (Permalloy head)  
 Playback head × 1 (Permalloy head) (TC-K620)  
 (LA head) (TC-K650ES)

Motors Capstan motor × 1  
 Reel motor × 1 (DC motor)

Wow and flutter 0.05% WRMS (NAB)  
 ±0.14% W. Peak (DIN)

Fast-forward and rewind time  
 Approx. 90 sec. (with C-60 cassette)

Frequency response (DOLBY NR off)

TYPE IV cassette (Sony METAL-ES)	20 – 20,000 Hz (± 3 dB) 20 – 16,000 Hz (OVU recording)
TYPE II cassette (Sony UX-S)	20 – 18,000 Hz (± 3 dB) (TC-K620) 20 – 19,000 Hz (± 3 dB) (TC-K650ES)
TYPE I cassette (Sony HF-S)	20 – 17,000 Hz (± 3 dB)

Signal-to-noise ratio (at peak level)

Cassette	Dolby NR switch		
	OFF	B-TYPE ON	C-TYPE ON
TYPE IV (Sony METAL-ES)	60 dB	69 dB	75 dB
TYPE II (Sony UX-S)	59 dB	68 dB	74 dB
TYPE I (Sony HF-S)	57 dB	66 dB	72 dB

Total harmonic distortion  
 1.0% (with Sony METAL-ES cassette)

Inputs

Line inputs (phono jacks)	Sensitivity	77.5 mV (–20 dB)
	Input impedance	50k ohms

Model Name Using Similar Mechanism	TC-RX70/RX70ES	
Tape Transport	TC-K620	TCM-200V2
Mechanism Type	TC-K650ES	TCM-200V3

Outputs

Line outputs (phono jacks)	Rated output level	0.44 V (–5 dB) at a load impedance 47k ohms
	Load impedance	Over 10k ohms
Headphones (stereo phone jack)	Output level	0–2.5 mW at a load impedance of 32 ohms

General

Power requirements AEP, West Germany models:  
 220 V AC (or 240 V adjustable, by Sony personnel), 50/60 Hz  
 US, Canadian models:  
 120 V AC, 60 Hz  
 UK model:  
 240 V AC, 50 Hz  
 E model: 120/220/240 V AC adjustable,  
 50/60 Hz

Power consumption 17 W  
 Dimensions Approx. 430 × 123 × 285 mm (w/h/d)  
 (17 × 4<sup>7</sup>/<sub>8</sub> × 11<sup>1</sup>/<sub>4</sub> inches)

Weight Approx. 4.9 kg (10 lbs 13 oz)

Supplied accessory Audio connecting cord (2)

Design and specifications subject to change without notice.

Note

This appliance conforms with EEC Directive 87/308/EEC regarding interference suppression.

**STEREO CASSETTE DECK**  
**SONY®**

## MODEL IDENTIFICATION

— Specification Label —

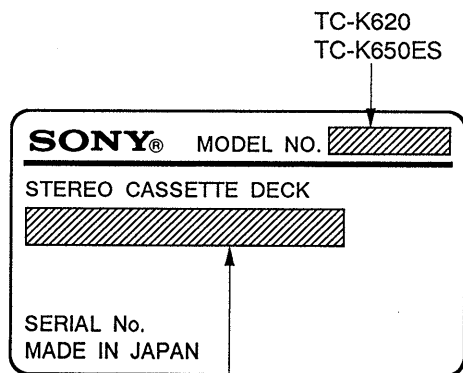



US, Canadian Models: AC: 120V 60Hz 17W  
 AEP, West Germany Model: AC: 220 V~50/60 Hz  
 UK Model: AC: 240 V~50 Hz  
 E Model: AC: 120, 220, 240 V~50/60 Hz 17W

## TABLE OF CONTENTS

<u>Section</u>	<u>Title</u>	<u>Page</u>
Specifications	.....	1
Model Identification	.....	2
Safety Check Out	.....	2
<b>1. GENERAL</b>	.....	3
<b>2. DISASSEMBLY</b>	.....	4
<b>3. ADJUSTMENTS</b>	.....	7
<b>4. DIAGRAMS</b>		
4-1.	Printed Wiring Boards	13
4-2.	Schematic Diagram — Audio Section —	17
4-3.	Schematic Diagram	
	— System Control Section —	20
<b>5. EXPLODED VIEWS</b>	.....	23
<b>6. ELECTRICAL PARTS LIST</b>	.....	27

### SAFETY-RELATED COMPONENT WARNING!!

COMPONENTS IDENTIFIED BY MARK  OR DOTTED LINE WITH MARK  ON THE SCHEMATIC DIAGRAMS AND IN THE PARTS LIST ARE CRITICAL TO SAFE OPERATION. REPLACE THESE COMPONENTS WITH SONY PARTS WHOSE PART NUMBERS APPEAR AS SHOWN IN THIS MANUAL OR IN SUPPLEMENTS PUBLISHED BY SONY.

### ATTENTION AU COMPOSANT AYANT RAPPORT À LA SÉCURITÉ!

LES COMPOSANTS IDENTIFIÉS PAR UNE MARQUE  SUR LES DIAGRAMMES SCHÉMATIQUES ET LA LISTE DES PIÈCES SONT CRITIQUES POUR LA SÉCURITÉ DE FONCTIONNEMENT. NE REMPLACER CES COMPOSANTS QUE PAR DES PIÈCES SONY DONT LES NUMÉROS SONT DONNÉS DANS CE MANUEL OU DANS LES SUPPLÉMENTS PUBLIÉS PAR SONY.

## SAFETY CHECK-OUT

After correcting the original service problem, perform the following safety check before releasing the set to the customer:

Check the antenna terminals, metal trim, “metallized” knobs, screws, and all other exposed metal parts for AC leakage. Check leakage as described below.

### LEAKAGE TEST

The AC leakage from any exposed metal part to earth ground and from all exposed metal parts to any exposed metal part having a return to chassis, must not exceed 0.5 mA (500 microampers). Leakage current can be measured by any one of three methods.

1. A commercial leakage tester, such as the Simpson 229 or RCA WT-540A. Follow the manufacturers' instructions to use these instruments.
2. A battery-operated AC milliammeter. The Data Precision 245 digital multimeter is suitable for this job.
3. Measuring the voltage drop across a resistor by means of a VOM or battery-operated AC voltmeter. The “limit” indication is 0.75 V, so analog meters must have an accurate low-voltage scale. The Simpson 250 and Sanwa SH-63Trd are examples of a passive VOM that is suitable. Nearly all battery operated digital multimeters that have a 2V AC range are suitable. (See Fig. A)

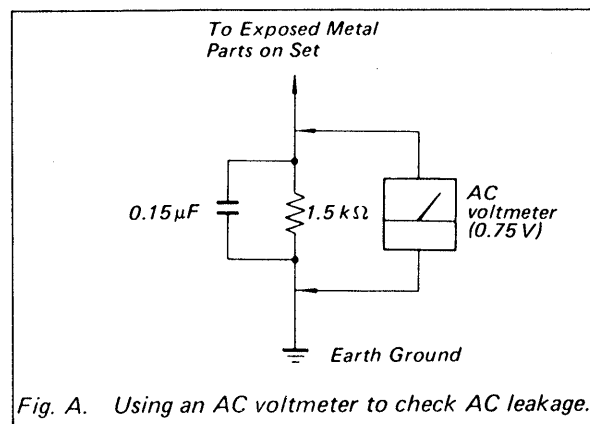
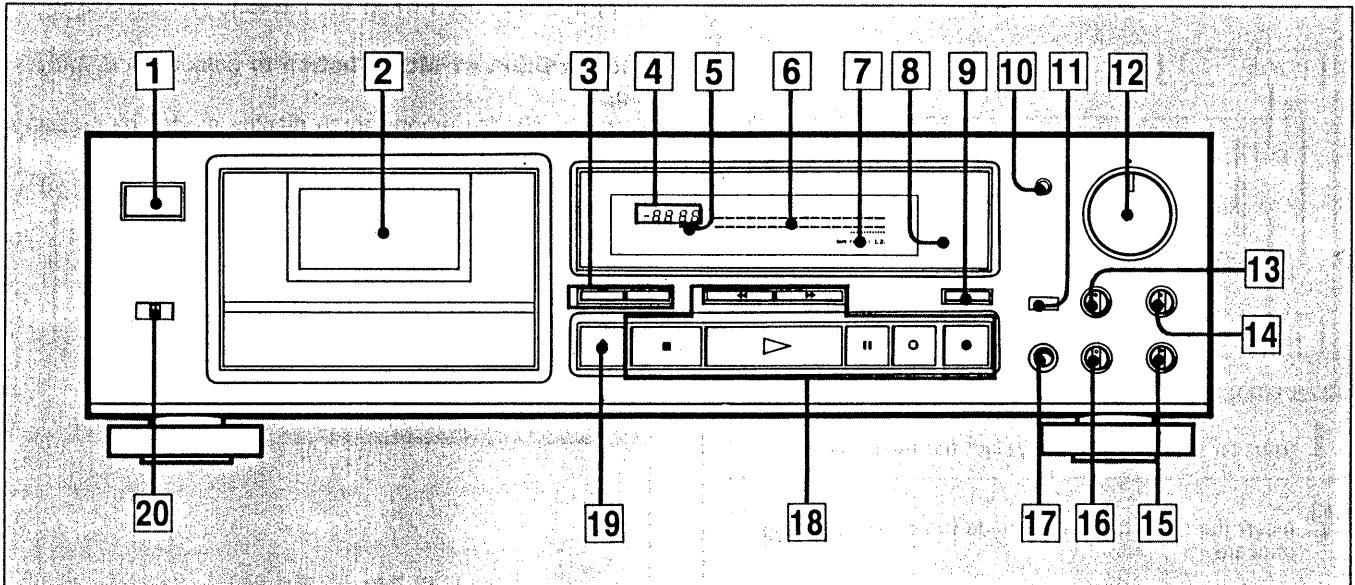











Fig. A. Using an AC voltmeter to check AC leakage.

## SECTION 1 GENERAL

### Identification of Front Panel Parts



- |   |   |
|---|---|
| <p><b>1</b> POWER switch</p> <p><b>2</b> Cassette holder</p> <p><b>3</b> COUNTER buttons<br/>RESET button/MEMORY button</p> <p><b>4</b> LINEAR COUNTER</p> <p><b>5</b> MEMORY indicator</p> <p><b>6</b> PEAK LEVEL METER</p> <p><b>7</b> TAPE TYPE indicator</p> <p><b>8</b> Remote sensor<br/>You can remotely control this cassette deck with:<br/>— A remote commander that has an  mark and comes with a Sony amplifier or receiver and which can be used to control a cassette deck.<br/>— An optional Sony remote commander that has an  mark.</p> <p><b>9</b> MONITOR button</p> <p><b>10</b> DISPLAY MODE button</p> <p><b>11</b> MPX FILTER switch</p> | <p><b>12</b> REC LEVEL (recording level) control</p> <p><b>13</b> DOLBY NR switch</p> <p><b>14</b> BALANCE control</p> <p><b>15</b> BIAS (bias adjust) control</p> <p><b>16</b> LEVEL (headphones level) control</p> <p><b>17</b> HEADPHONES jack (stereo phone jack)</p> <p><b>18</b> Tape operation buttons<br/>  (rewind) button<br/>  (fast-forward) button<br/>  (stop) button<br/>  (play) button (AMS*)<br/>  PAUSE button<br/>  REC MUTE (record muting) button<br/>  REC (record) button</p> <p><b>19</b>  OPEN/CLOSE button</p> <p><b>20</b> TIMER switch</p> |
|---|---|

\* AMS is an abbreviation for Automatic Music Sensor.

## SECTION 2 DISASSEMBLY

Note: Follow the disassembly procedure in the numerical order given.

Unscrew the four case attachment screws M3 × 8 and remove the upper case.

### AUDIO SYSTEM CONTROL BOARD

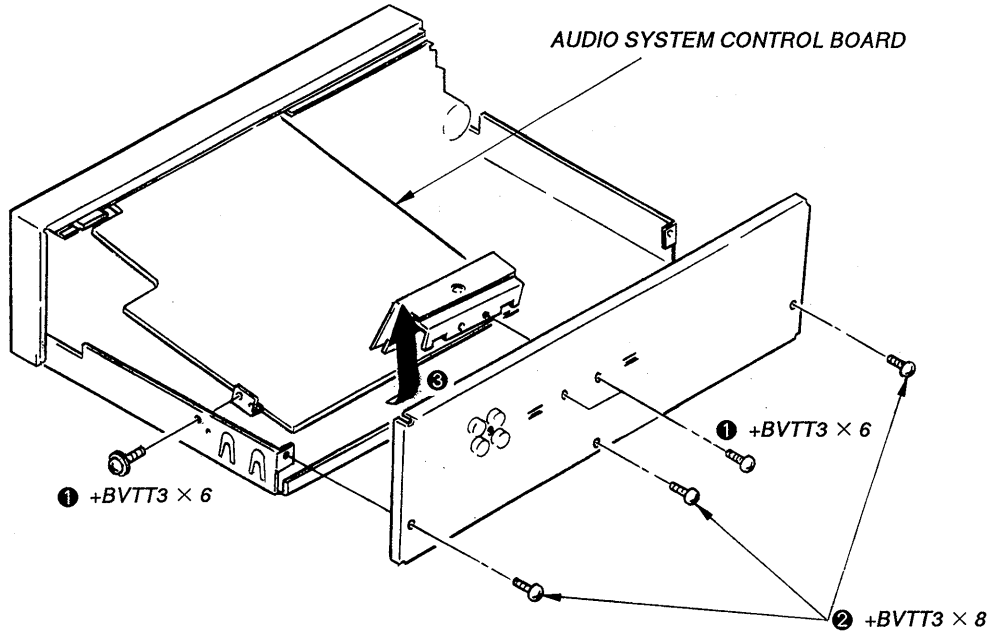

### MECHANISM

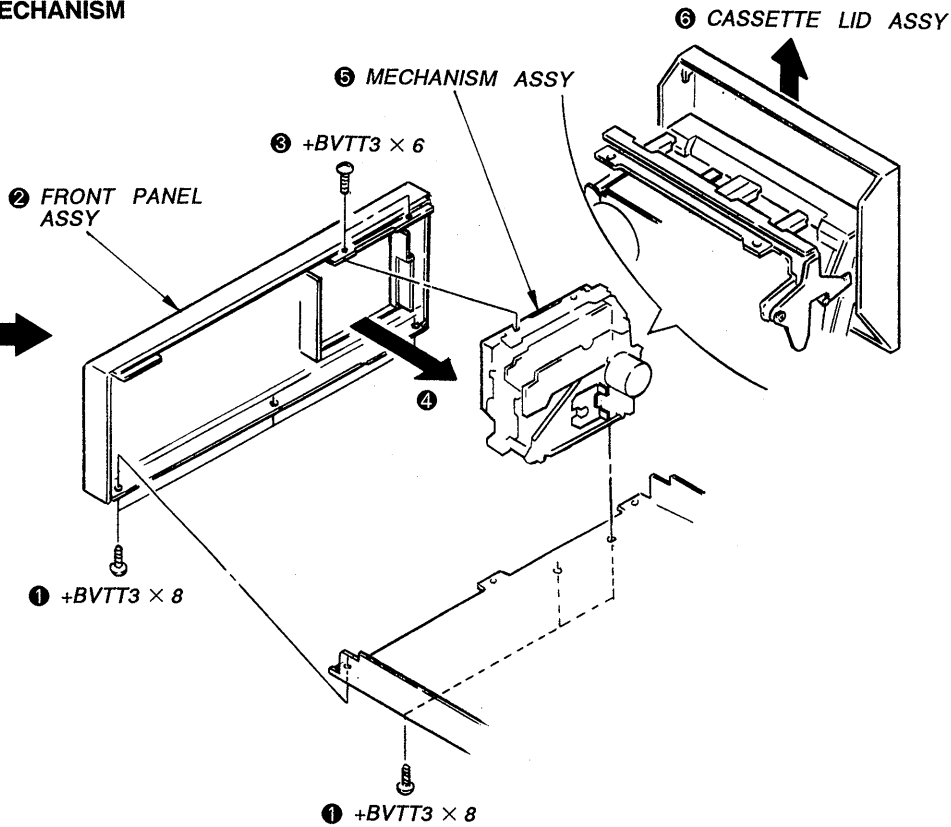

**CASSETTE HOLDER**

3 Push LEVER (LIFTER) in the direction of arrow and remove CASSETTE HOLDER.

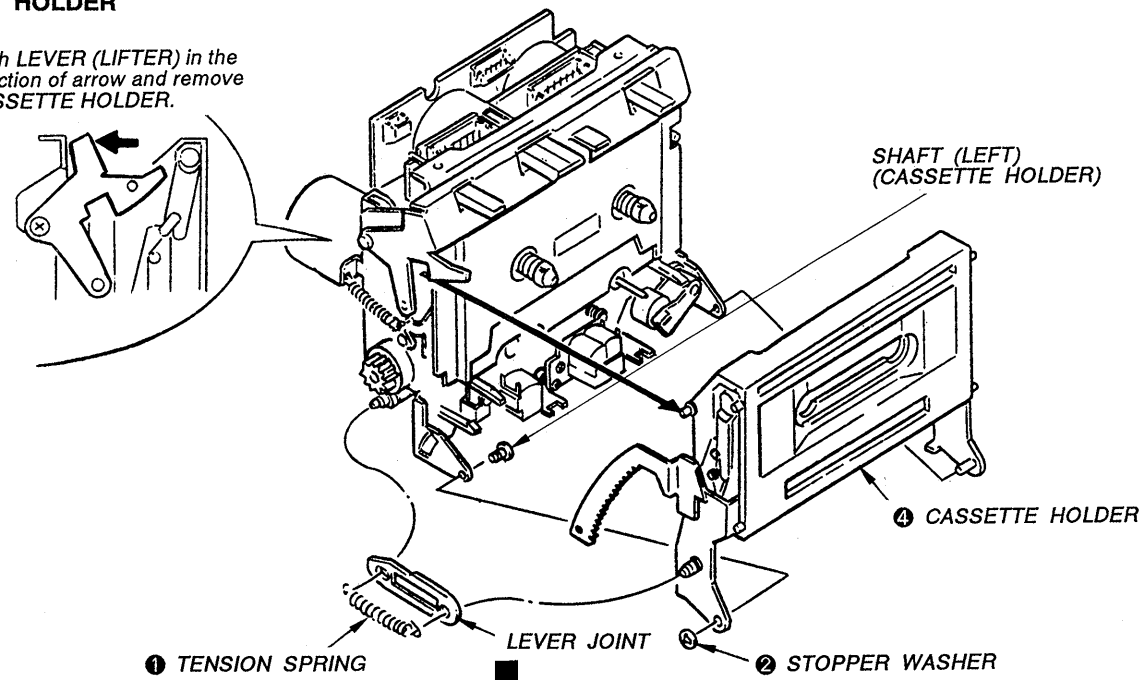

**ORNAMENTAL PLATE**

2 Push LEVER (LIFTER) in the direction of arrow and remove ORNAMENTAL PLATE.

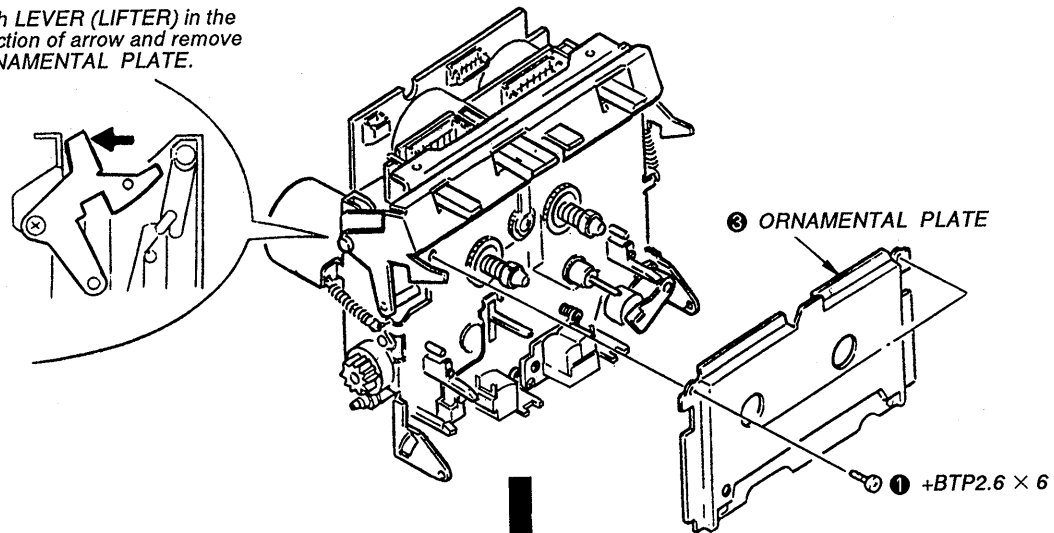

**PINCH LEVER**

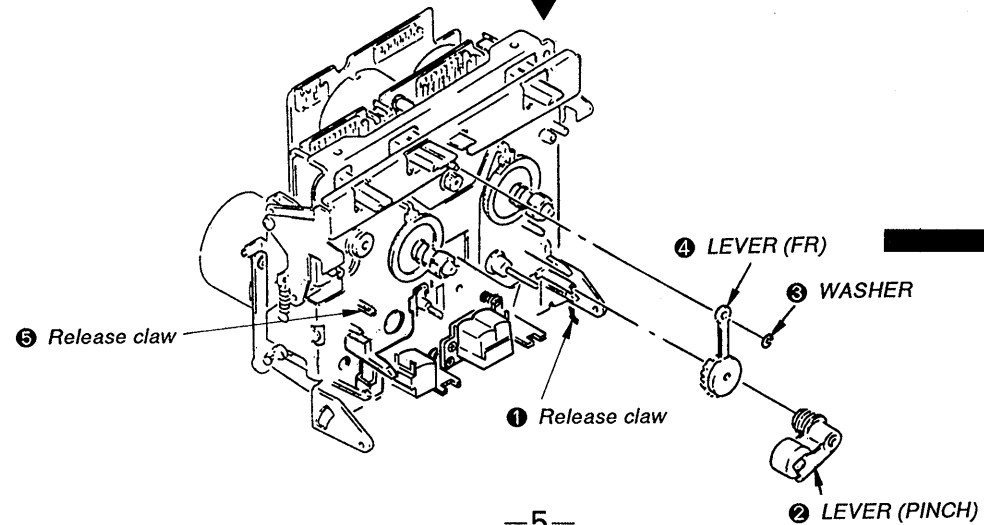

**CAPSTAN MOTOR/FLYWHEEL**

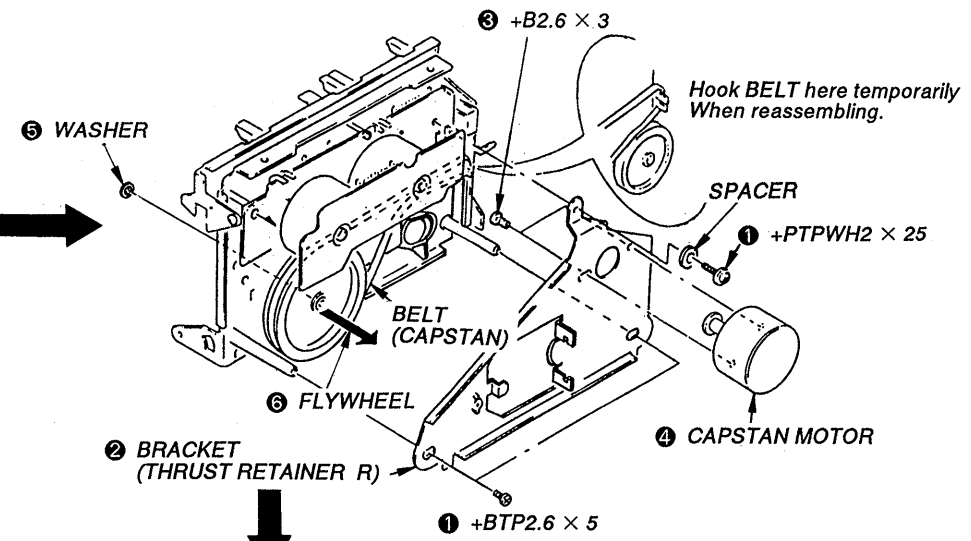

**REEL AND ASSIST MOTORS**

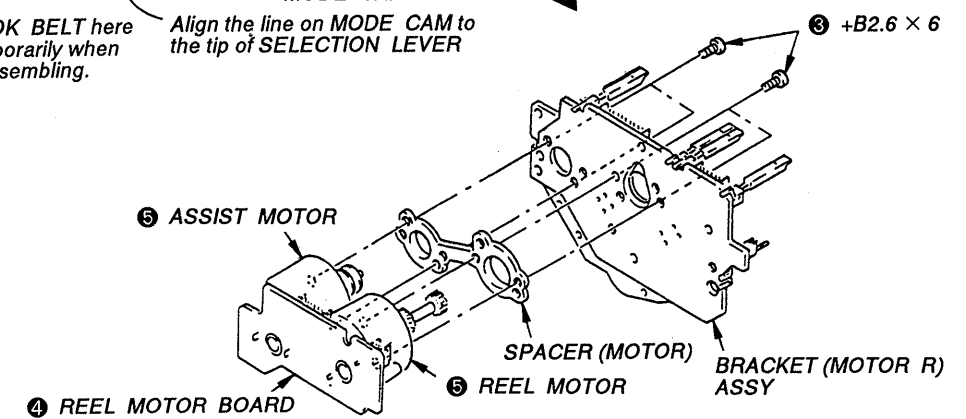
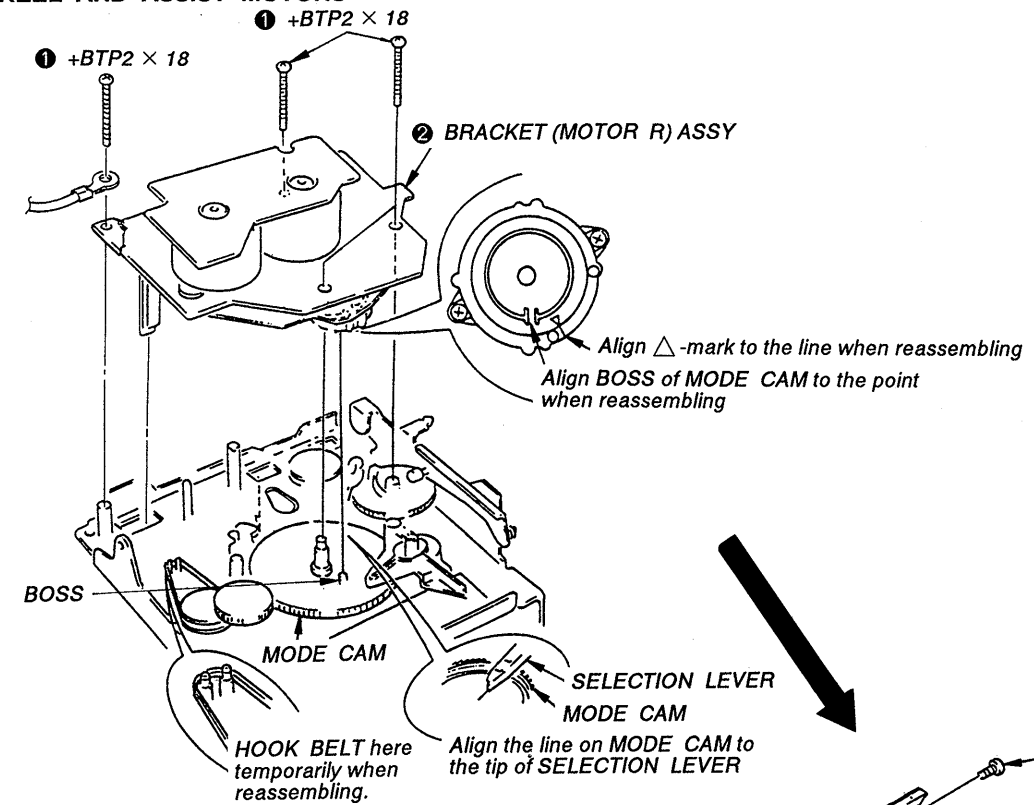

# SECTION 3 ADJUSTMENTS

## 1. MECHANICAL ADJUSTMENTS

### PRECAUTION

- Clean the following parts with a denatured-alcohol-moistened swab:
 

record/playback head	pinch roller
erase head	rubber belts
capstan	idler
- Demagnetize the record/playback head with a head demagnetizer.
- Do not use a magnetized screwdriver for the adjustments.
- After the adjustments, apply suitable locking compound to the parts adjusted.

### TORQUE MEASUREMENT

Torque	Torque meter	Meter reading
FWD	CQ-120C	30 – 60 g•cm (0.42 – 0.83 oz•inch)
FWD Back tension	CQ-102C	1 – 5 g•cm (0.014 – 0.069 oz•inch)
FF, REW	CQ-201B	70 – 120 g•cm (0.97 – 1.68 oz•inch)

### Tape Path Adjustment

- Refer to adjustment Position on page 8.

**Note:** When using the adjustment methods for other than replacement reasons.

### Preparation:

- Mirror cassette CQ009C 8-909-708-01  
(or CQ012C 8-909-708-02)

If one does not have this, cut out the sections of a 120-minute cassette shell as indicated below and use that cassette.

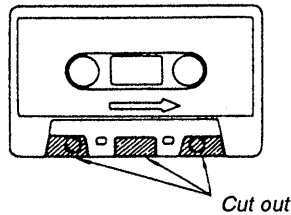

- Phillips screwdriver (medium-size):  
For the head adjustment screws
- Pen light
- WS-48B (3 kHz, 0 dB)
- P-4-A100 (10 kHz, - 10 dB)

Definition of Terms: The figures are of a record/playback head.

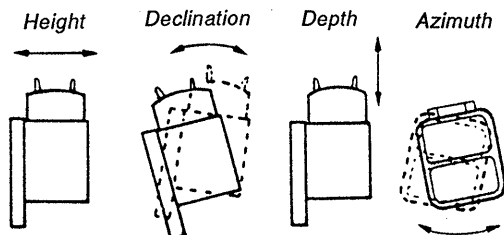

### Record/playback Head

**Note:** Only perform this adjustment when the record/playback head is to be replaced.

- Insert the mirror cassette and put the unit in record/playback mode.
- (Height adjustment) Check to see if the tape is curling at the tape guide of the head. If it is curling tighten screws **A**, **B**, and **C**, respectively by the same angle moving the head so that it remains at the same angle through-out the procedure. If it curls on the bottom side of the mirror cassette (actually the inner side), tighten all the screws equally; but loosen them if the tape begins to curl on the top side (outer side).

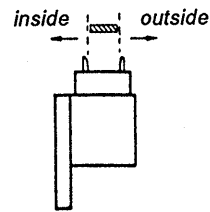

*normal*  
(record/playback head as seen from the side of the erasehead.)

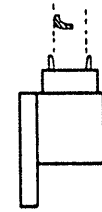

*Curling on the inner side.*  
Tighten screws **A**, **B** and **C**.

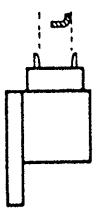

*Curling on the outer side.*  
Loosen screws **A**, **B**, and **C**.

3. (Declination Adjustment) While in the record/playback position, set the back tension to 0 (wind the supply reel with something thin like a pencil in a counterclockwise direction) and make sure there is no curling or shifting (shifting up/shifting down) at the guide of the record/playback head.  
Because shifting can only occur due to a difference in the width of the tape and that of the tape guides (curling will otherwise occur), it is necessary to pay close attention since it can be easily overlooked.  
When there is a shift, tighten screws **B** and **C** equally and change the declination of the head. If the tape is shifting up, tighten the screws, and if it is shifting down, loosen them.
4. Repeat the adjustments in steps 2 and 3 and fine adjust the height and the declination.
5. (Preliminary Azimuth Adjustment)  
After demagnetizing and cleaning the adjustment head, play back WS-48B (3 kHz, 0 dB).  
Turn screw **C** so that the reading on the level meter of the unit or that of the level meter connected to LINE OUT is maximized.  
If the screw is turned at least half a revolution, repeat the adjustments from step 1.
6. (Tape Path Check) Connect the oscilloscope to LINE OUT and play back P-4-A100 (10 kHz, - 10 dB) to display a resurge waveform. After 20 seconds of record/playback (after the tension within the loop has been increased sufficiently), make sure the variation in the resurge is within  $\pm 90$  degrees (within  $\pm 45$  degree is desired).  
If the variation is greater than this, it is because the declination and/or the height adjustment is not perfect. Repeat the adjustments from step 1.
7. After adjustment is completed, be sure to fix the height adjustment screw **A**, **B** by locking compound.

test tape  
P-4-100S  
(10 kHz, - 10 dB)

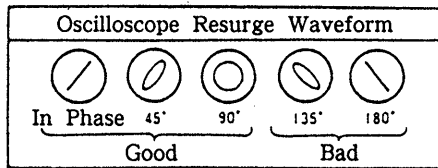
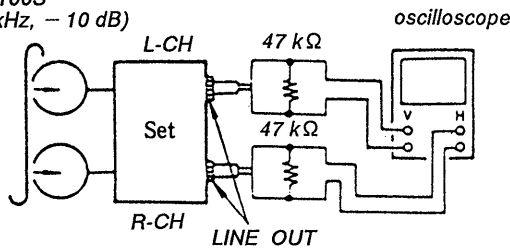

**Adjustment Position:** As seen from the cassette, side (top) and MD as seen head on (bottom).

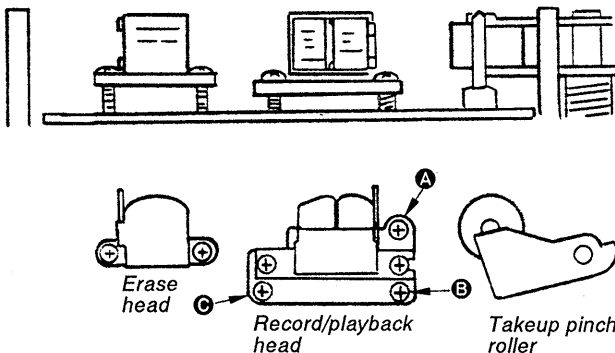

## 2. ELECTRICAL ADJUSTMENT

**Note:** The adjustment should be performed in the order given in the service manual. As a rule, adjustments about playback should be performed before those about recording.

The adjustments should be performed before for both L-CH and R-CH.

- Switches and controls should be set as follows unless otherwise specified.  
DOLBY NR switch: OFF  
MPX FILTER switch: OFF  
MONITOR switch: Tape
- Standard Record:  
Deliver the standard input signal level to the input jack and set the REC LEVEL control to obtain the standard output signal level.

— Record Mode —

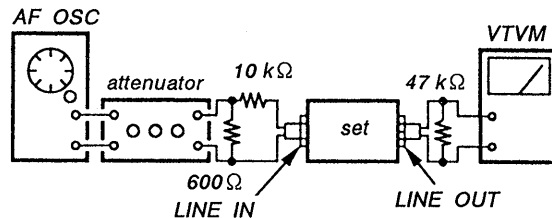

### Standard Input Level

input terminal	LINE IN
source impedance	10 kΩ
input level	0.25 V (- 10 dB)

### Standard Output Level

output terminal	LINE OUT
load impedance	47 kΩ
output level	0.44V (- 5 dB)

### Test Tape

Type	Signal	Used for
P-4-A100	10 kHz, - 10 dB	Azimuth Adjustment
P-4-L300	315 Hz, 0 dB	PB Level Adjustment
WS-48B	3 kHz, 0 dB	Tape Speed Adjustment

### Test Mode

This set will get into test mode by shorting the pins of TP701 (TEST) on Audio system control (A) board before turning the power on.

### Record/Playback Head Azimuth Adjustment

#### Procedure:

1. Mode: FWD playback

Test tape  
P-4-A100  
(10 kHz, -10 dB)

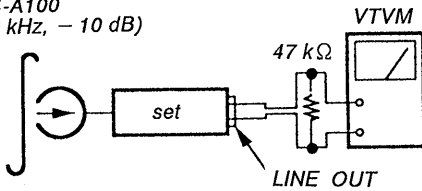

2. Turn the adjustment screw for the maximum output levels. If these levels do not match, turn the adjustment screw until both of output levels match together within 1 dB.

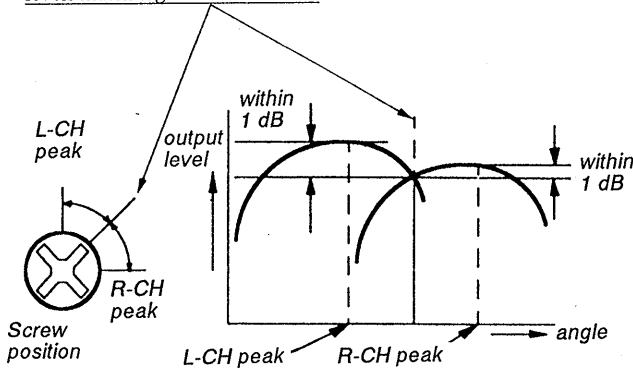

3. Phase Check  
Mode: playback

test tape  
P-4-A100  
(10 kHz, -10 dB)

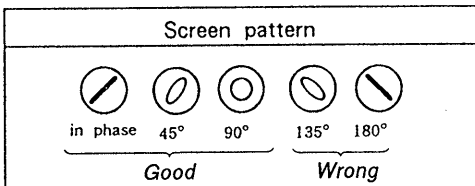
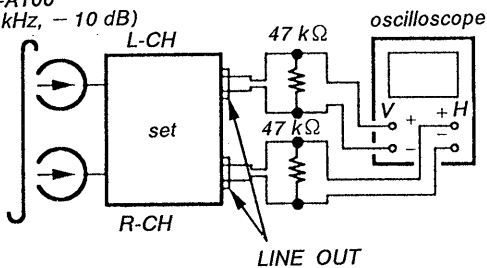

4. After the adjustment, lock the screws with locking compound.

### Adjustment Location: Record/Playback head

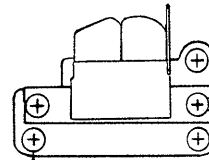

Adjustment screw

### Tape Speed Adjustment

#### Setting:

Test pin TP701: short

#### Procedure:

Mode: playback

test tape  
WS-48B  
(3 kHz, 0 dB)

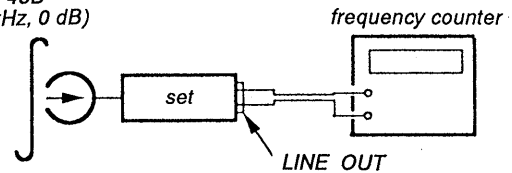

1. Set to FWD playback mode.
2. Adjust motor rear side (variable resistor) so that the frequency counter reading becomes  $3,000 \pm 15$  Hz.

### Adjustment Location: motor rear side

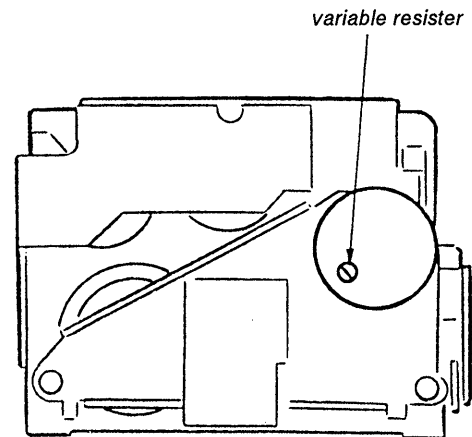



## Playback Level Adjustment

### Procedure:

Mode: playback  
test tape  
P-4-L300  
(315 kHz, 0 dB)

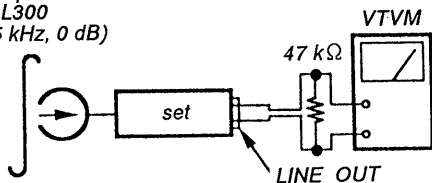

Adjust RV121 (L-ch) and RV221 (R-ch) so that the reading on VTVM meets the adjustment limits below.

### Adjustment Limits:

LINE OUT level:  $-5 \pm 0.5$  dB (0.41 – 0.46 V)

Level difference between channels: less than 0.5 dB

Check that the LINE OUT level does not change even if Playback and Stop operation is repeated several times.

**Adjustment Location:** Audio system control (A) board

## Bias Current adjustment

### Procedure:

LINE IN  
(no signal)

CS-413 blank tape

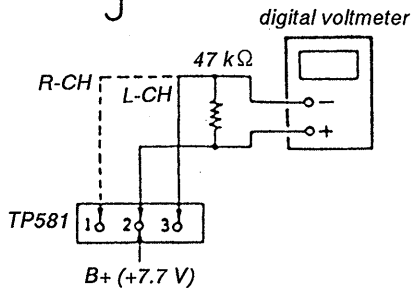
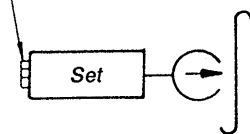

1. Set RV181 and RV281 to mechanical center and turn the set recording mode.
2. Connect digital voltmeter as shown by the following table.
3. Adjust the following transformers for the minimum readings on the digital voltmeter.

	Mesurement Point	Adjustment Part	Value
L-ch	③ and ②, TP581	T101	not more than 80 mV
R-ch	① and ② TP581	T301	80 mV

**Adjsutment Location:** Audio system control (A) board

## Record Bias Adjustment

### Setting:

REC LEVEL control: Standard Record (see page 8).  
test pin TP701: short

### Procedure:

1. Mode: record

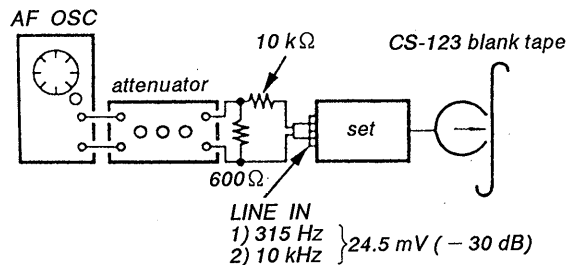

2. Mode: playback

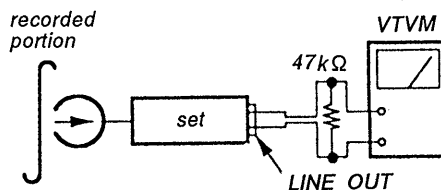

Playback the signal recorded in step 1.

Confirm that the 10 kHz playback output is  $0.7 \pm 0.5$  dB relative to the 315 Hz output. If necessary, adjust RV181 (L-ch) and RV281 (R-ch) for repeat the steps given above.

**Adjustment Location:** Audio system control (A) board

## Record Level Adjustment

### Setting:

REC LEVEL control: Standard Record (See page 8.)  
test pin TP701: short

### Procedure:

1. Mode: record  
Blank tape CS-123

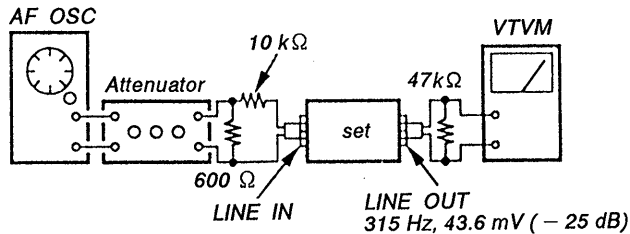

2. Mode: playback  
recorded portion

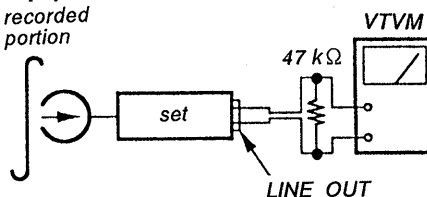

3. Playback the signal recorded in step 1.  
Confirm that the signal level is within the adjustment limits below. If necessary, adjust RV141 (L-ch) and RV241 (R-ch) repeat the step 1 – 2.

**Adjustment Limits:**  $-25$  dB  $\pm 0.5$ dB (42 – 46 mV)

**Adjustment Location:** Audio system control (A) board

**Adjustment Location**

– AUDIO SYSTEM CONTROL (A) BOARD –

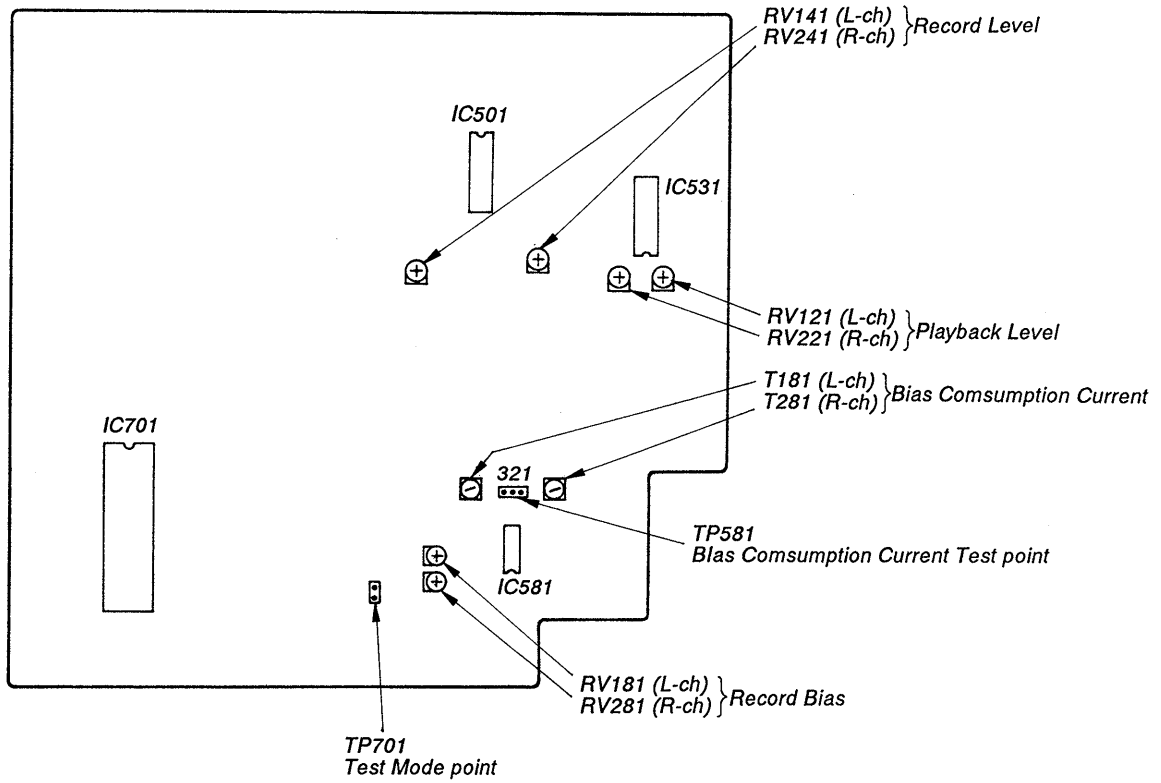

# SECTION 4 DIAGRAMS

## • Circuit Boards Location

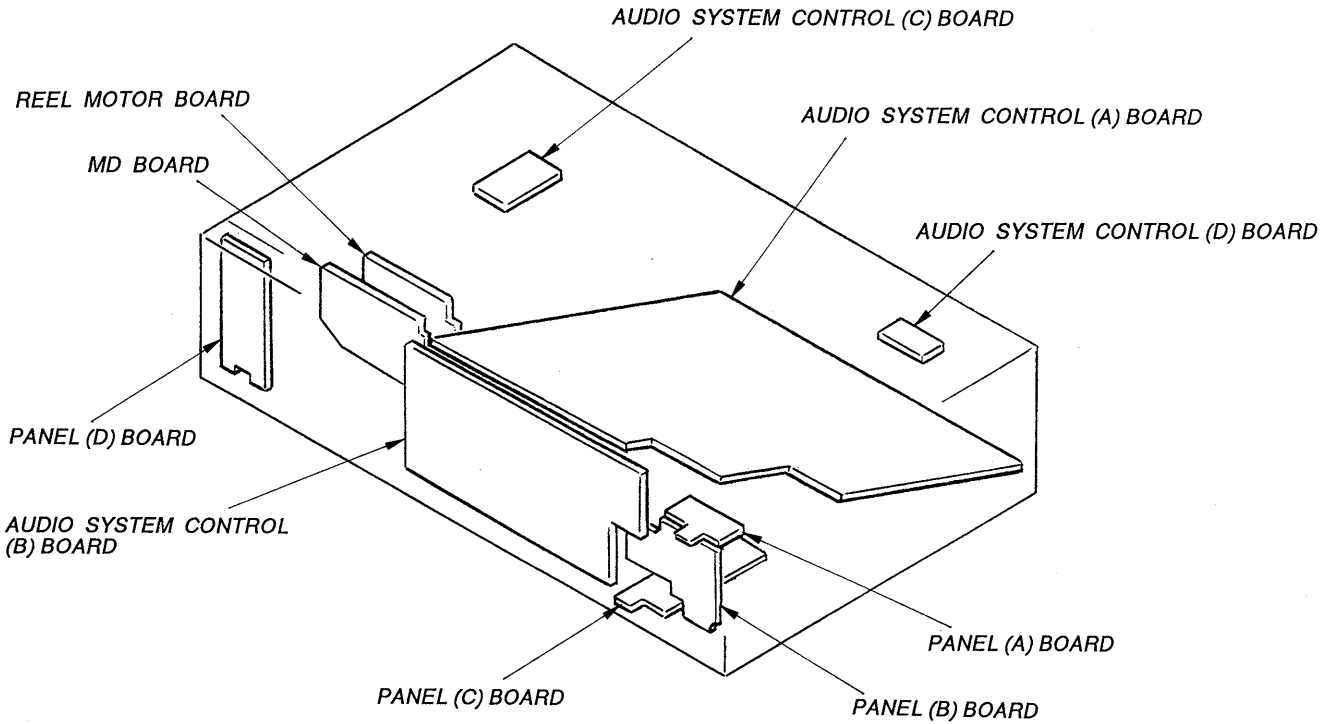

## • Semiconductor Lead Layouts

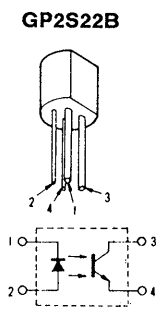
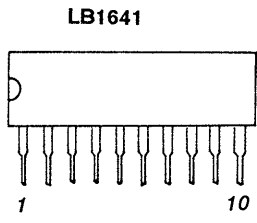
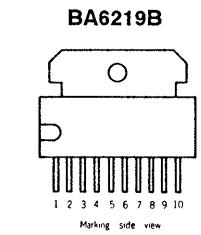

DTA114ES  
DTA144ES  
DTC114ES  
DTC143TS  
DTC144ES  
2SC2603-EF

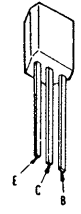

**2SA1175-HFE**

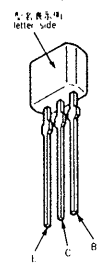

**2SB1116A-L  
2SC945-P**

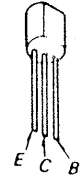

**2SB1187-EF  
2SD1761-EF**

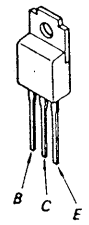

**HZS6A1L  
HZS6B1L  
UZL-7H1  
UZL-12M1  
1SS202-1**

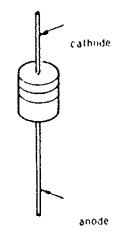

**10E2N**

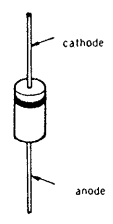

Note:  
 • — : parts extracted from the component side.  
 • — : indicates side identified with part number.

• Semiconductor Location

Ref. No.	Location	Ref. No.	Location
D161	F-10	IC751	H-19
D261	F-9	IC801	D-9
D501	D-5	IC1001	I-3
D502	G-14	IC1002	I-4
D503	G-14		
D541	G-14	O101	G-9
D542	G-14	O102	H-9
D543	G-14	O121	J-13
D561	E-13	O141	G-12
D582	J-16	Q201	H-9
D583	G-15	Q202	H-9
D584	G-14	Q221	J-13
D701	F-15	Q241	H-12
D702	F-15	O501	G-13
D703	B-14	O502	G-12
D704	B-14	O503	G-13
D705	B-14	O504	J-10
D706	D-15	O541	G-14
D707	D-15	O542	G-14
D710	D-4	O543	G-14
D711	D-4	O561	E-13
D752	F-19	O581	I-16
D753	F-19	O582	I-16
D754	F-19	O583	G-15
D755	F-19	O584	G-15
D801	D-10	O585	I-15
D802	C-11	O586	J-15
D803	C-11	Q701	E-15
D804	C-11	Q702	E-15
D805	D-9	Q703	E-15
D806	E-9	Q704	E-15
D807	B-12	Q705	B-13
D808	B-11	Q706	B-13
D809	B-11	Q707	D-15
D810	B-11	Q708	D-15
D811	B-11	Q709	B-16
D812	C-12	Q710	D-13
D813	C-11	Q711	B-16
D814	D-12	Q712	D-13
D815	B-12	Q713	D-14
D816	C-10	Q714	B-16
D817	C-9	Q715	D-17
D818	C-11	Q716	D-17
D819	D-12	Q751	D-17
D820	C-12	Q753	E-17
D822	C-12	Q754	E-17
D1051	G-4	Q755	E-17
		Q756	E-17
IC501	H-11	Q757	F-17
IC502	J-9	Q758	F-17
IC521	J-14	O801	D-9
IC531	J-11	O802	D-9
IC541	I-13	O803	D-10
IC551	G-7	O804	E-10
IC561	E-13	O805	D-12
IC562	F-9	O806	D-12
IC581	H-16	O807	C-9
IC701	C-15	O808	C-10
IC702	F-15	O809	C-9
IC703	C-13	O810	C-12
IC704	B-13	O811	D-12

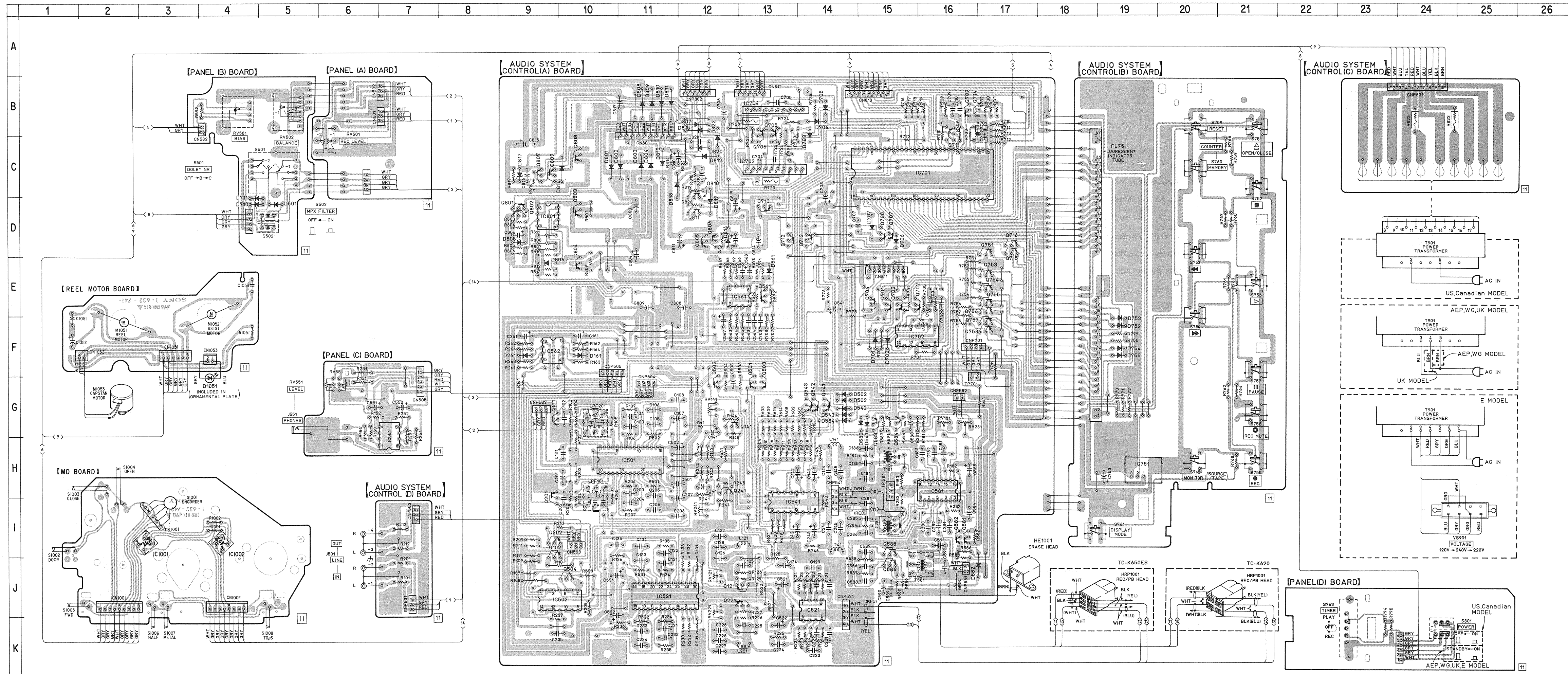

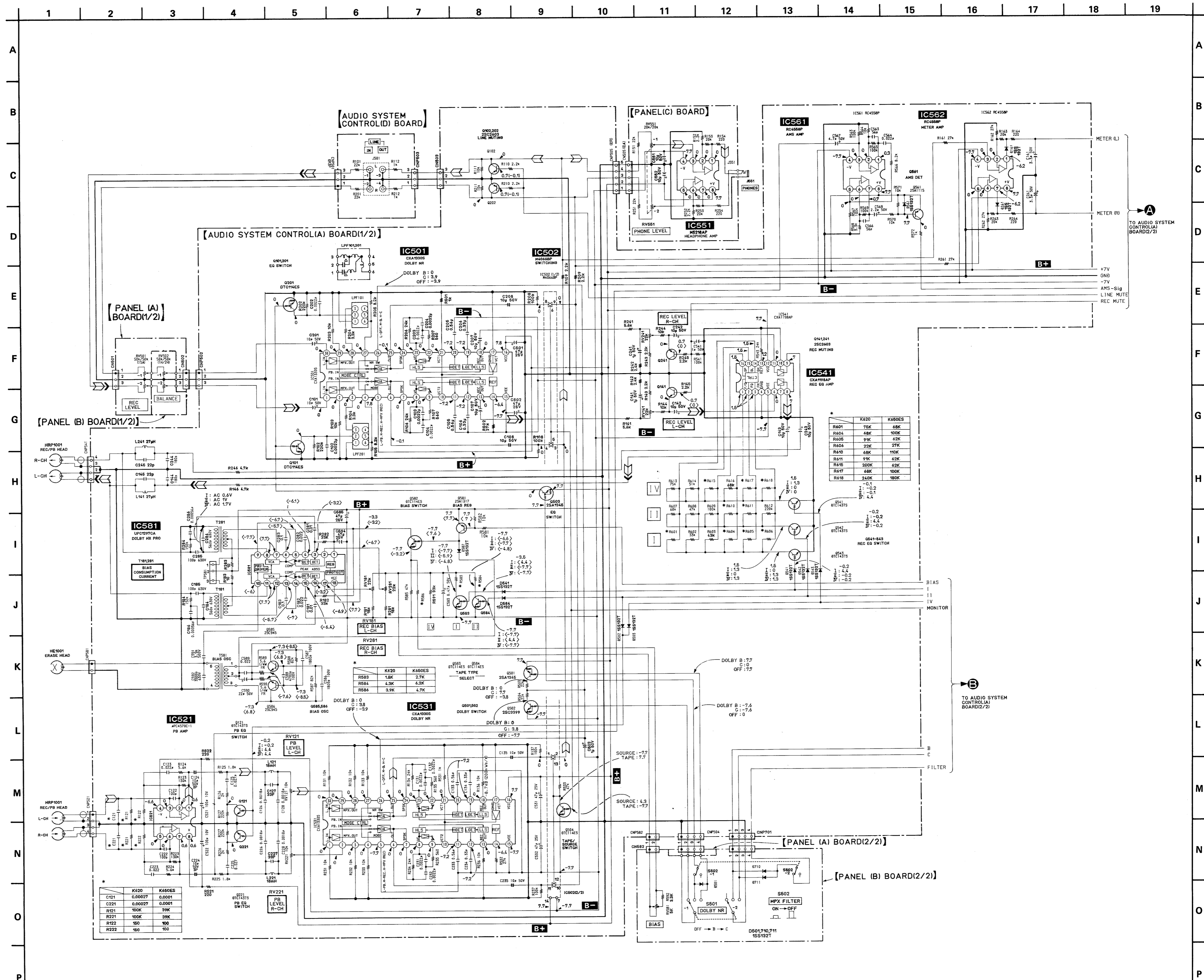

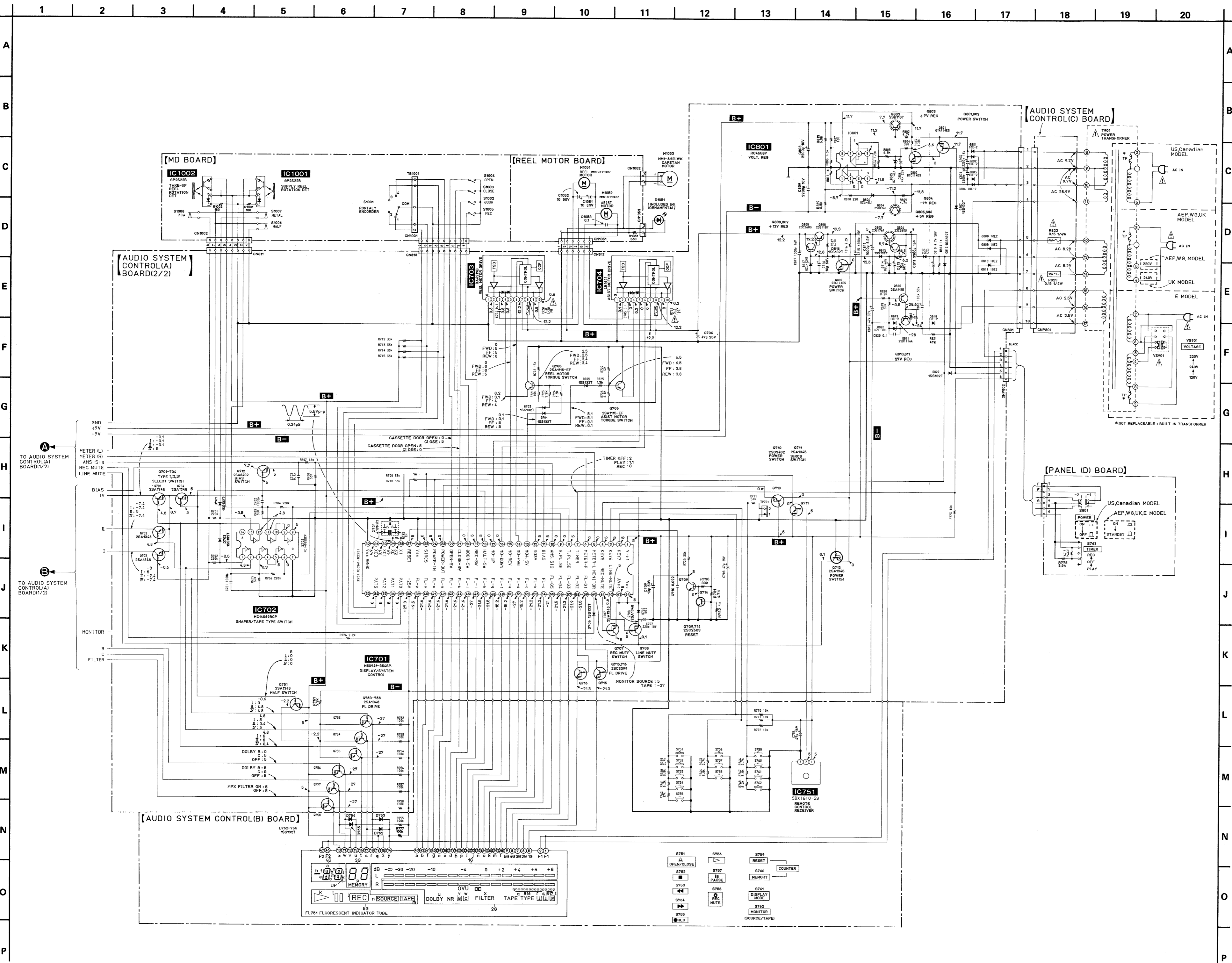

### SECTION 5 EXPLODED VIEWS

**NOTE:**

- The mechanical parts with no reference number in the exploded views are not supplied.
- The construction parts of an assembled part are indicated with a collation number in the remark column.
- Items marked "★" are not stocked since they are seldom required for routine service. Some delay should be anticipated when ordering these items.

- Due to standardization, parts with part number suffix -XX and -X may be different from the parts specified in the components used on the set.
- Color Indication of Appearance Parts  
Example:  
(RED) ... KNOB, BALANCE (WHITE)  
↑ Cabinet's Color                      ↑ Parts' Color
- WG: West Germany model

The components identified by mark or dotted line with mark are critical for safety. Replace only with part number specified.

Les composants identifiés par une marque sont critiques pour la sécurité. Ne les remplacer que par une pièce portant le numéro spécifié.

**(1) FRONT PANEL SECTION**

- A: PANEL (B) BOARD
- B: PANEL (C) BOARD
- C: PANEL (D) BOARD

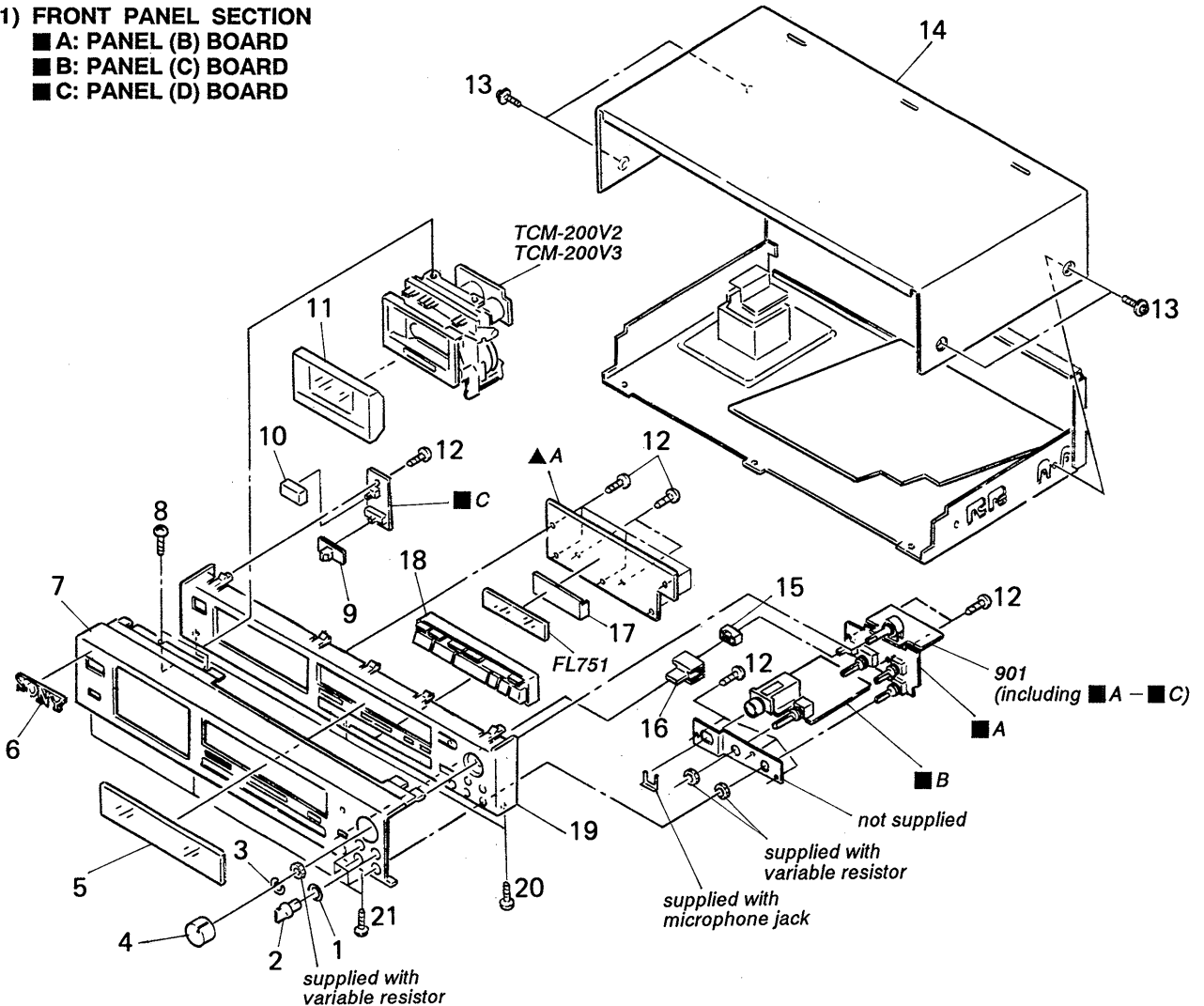

No.	Part No.	Description	Remarks	No.	Part No.	Description	Remarks
1	3-356-957-01	SPRING		11	X-3304-974-1	(K620:US)....LID ASSY, CASSETTE	
2	3-350-495-01	KNOB (VOL)			X-3304-975-1	(K620:AEP,WG,Canadian)	
3	3-350-440-01	SPRING				...LID ASSY, CASSETTE	
4	X-3304-973-1	KNOB (R) ASSY			X-3304-976-1	(K650ES)....LID ASSY, CASSETTE	
5	3-350-838-21	WINDOW (M)		12	4-928-635-01	SCREW, +BV (2.6X8) TAPPING	
6	4-908-848-01	EMBLEM, SONY		13	3-704-366-01	SCREW (CASE) (M3X8)	
7	3-356-977-01	(K620:US,Canadian)...PANEL, FRONT		14	3-332-578-61	CASE	
	3-356-977-11	(K620:AEP,WG).....PANEL, FRONT		15	4-864-307-00	RING	
	3-356-977-21	(K620:US).....PANEL, FRONT		16	3-304-926-11	KNOB (A), PUSH	
	3-356-977-31	(K650ES:UK).....PANEL, FRONT		17	*3-350-824-01	HOLDER (FL)	
	3-356-977-41	(K650ES:E).....PANEL, FRONT		18	3-356-975-01	BUTTON	
8	7-682-547-04	SCREW +BVTT 3X6 (S)		19	3-350-842-11	PANEL (BASE)	
9	4-931-421-11	KNOB (T & S)		20	7-682-548-09	SCREW +BVTT 3X8 (S)	
10	4-922-921-01	BUTTON (POWER)		21	7-685-534-19	SCREW +BTP 2.6X8 TYPE2 N-S	
				901	*1-635-796-11	PC BOARD, PANEL	
				FL751	1-519-596-11	INDICATOR TUBE, FLUORESCENT	

(2) CHASSIS SECTION

- ▲ A: AUDIO SYSTEM CONTROL (B) BOARD
- ▲ B: AUDIO SYSTEM CONTROL (C) BOARD
- ▲ C: AUDIO SYSTEM CONTROL (D) BOARD

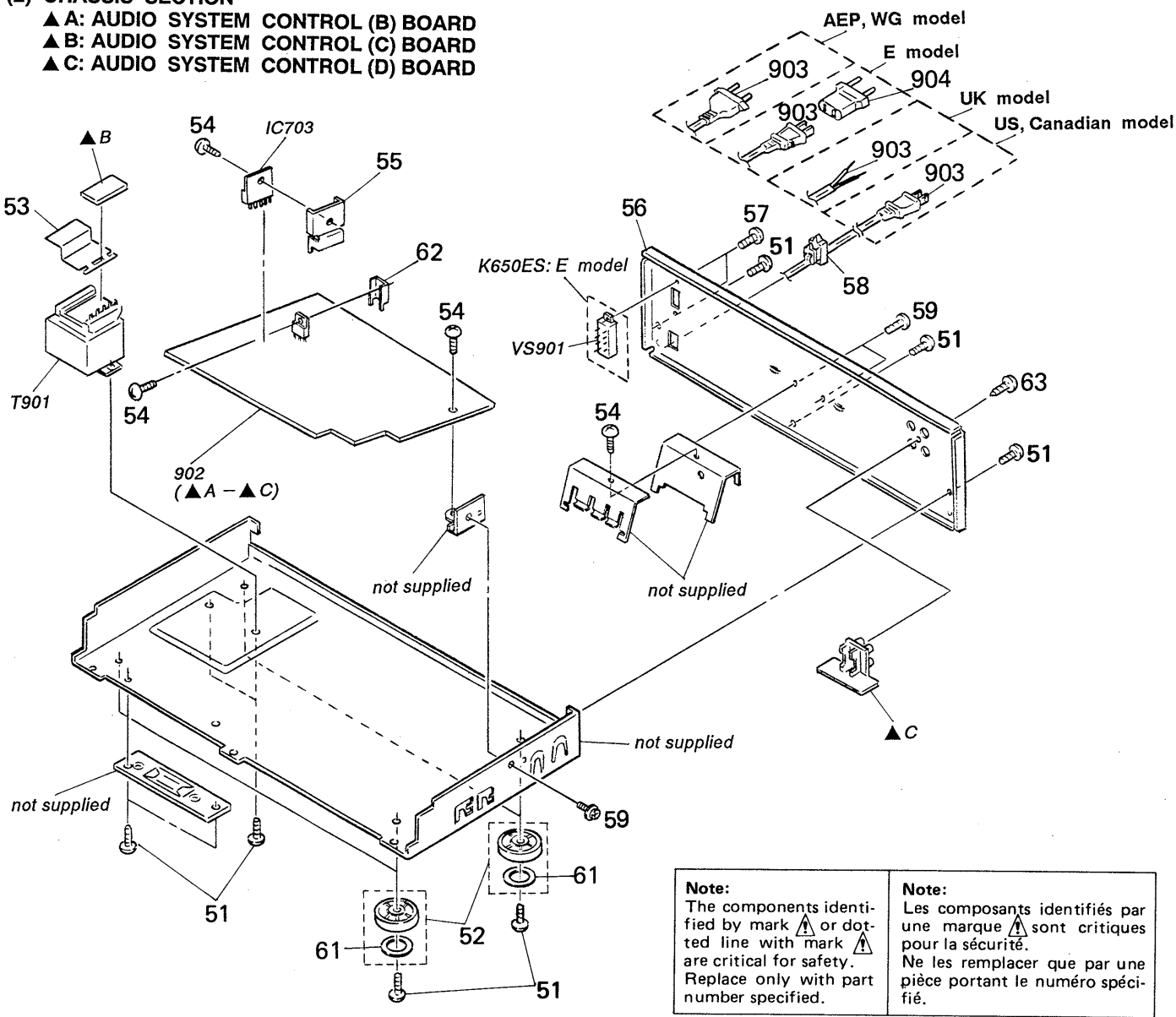

<p><b>Note:</b> The components identified by mark ▲ or dotted line with mark ▲ are critical for safety. Replace only with part number specified.</p>	<p><b>Note:</b> Les composants identifiés par une marque ▲ ou trait pointillé avec marque ▲ sont critiques pour la sécurité. Ne les remplacer que par une pièce portant le numéro spécifié.</p>
--	---

No.	Part No.	Description	Remarks	No.	Part No.	Description	Remarks
51	7-682-548-09	SCREW +BVTT 3X8 (S)		59	7-682-547-09	SCREW +BVTT 3X6 (S)	
52	X-3304-938-2 X-4885-950-1	(K620:AEP,WG/K650ES)...FOOT ASSY (K620:US,Canadian).....FOOT ASSY		61	4-923-836-11	CUSHION	
53	*3-337-136-11	COVER, TRANSFORMER SAFETY		62	*3-309-144-21	HEAT SINK	
54	7-682-547-04	SCREW +BVTT 3X6 (S)		63	7-621-849-00	SCREW, TAPPING	
55	*3-356-925-01	HEAT SINK		902	*A-2006-271-A *A-2006-273-A	(K620)....MOUNTED PCB, SYSTEM CONTROL (K650ES)...MOUNTED PCB, SYSTEM CONTROL	
56	*3-356-978-01 *3-356-978-21 *3-356-979-01 *3-356-979-11 *3-356-979-21	(K620:US,Canadian)...PANEL, BACK (K620:AEP,WG).....PANEL, BACK (K650ES:US).....PANEL, BACK (K650ES:UK).....PANEL, BACK (K650ES:E).....PANEL, BACK		903	▲.1-551-188-XX ▲.1-551-506-XX ▲.1-555-795-00 ▲.1-556-035-00	(E).....CORD, POWER (US,Canadian)...CORD, POWER (K620:AEP,WG)...CORD, POWER, EULO PLUG (UK).....CORD, POWER	
57	7-685-534-19	SCREW +BTP 2.6X8 TYPE2 N-S		904	1-569-007-11 IC703 8-759-973-95	(E)...ADAPTER, CONVERSION 2P IC BA6219B	
58	*3-703-244-00 *3-703-571-11	(AEP,WG,UK).....BUSHING(2104), CORD (US,Canadian,E)...BUSHING(S)(4516), CORD		T901	▲.1-450-099-11 ▲.1-450-100-11 ▲.1-450-101-11	(AEP,WG,UK).....TRANSFORMER, POWER (US,Canadian)...TRANSFORMER, POWER (E).....TRANSFORMER, POWER	
				VS901	▲.1-570-307-11	(E)...SWITCH, VOLTAGE CHANGE	



(3) MECHANISM SECTION (K620: TCM-200V2)  
(K650: TCM-200V3)

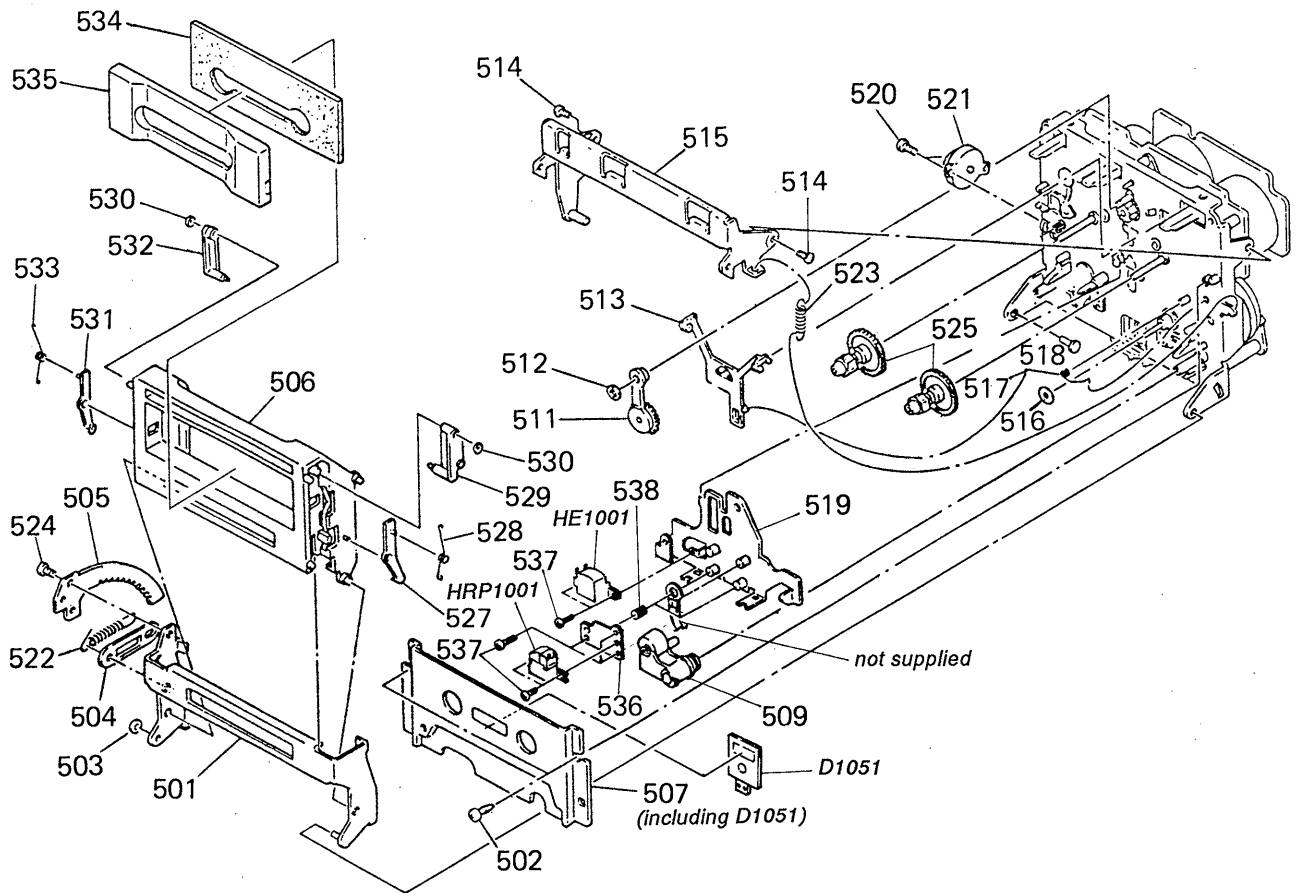

No.	Part No.	Description	Remarks	No.	Part No.	Description	Remarks
501	X-3356-612-1	HOLDER (B) ASSY, CASSETTE		523	3-356-625-01	SPRING, TENSION	
502	7-685-133-19	SCREW +BTP 2.6X6 TYPE2 N-S		524	7-621-775-10	SCREW +B 2.6X4	
503	3-558-708-21	WASHER, STOPPER		525	X-3356-627-1	GEAR (T) ASSY	
504	*3-356-717-01	LEVER (JOINT)		527	3-356-930-01	LEVER (RA)	
505	3-356-708-01	GEAR (SOFT EJECT)		528	3-356-926-01	SPRING (RIGHT), TORSION	
506	X-3356-611-1	HOLDER (A) ASSY, CASSETTE		529	3-356-931-01	LEVER (RB)	
507	X-3356-613-1	PLATE ASSY, ORNAMENTAL		530	3-356-946-01	BUSHING	
509	X-3356-649-1	LEVER (PINCH LEVER T) ASSY		531	3-356-932-01	LEVER (LA)	
511	X-3356-641-1	LEVER (FR2) ASSY		532	3-356-933-01	LEVER (LB)	
512	3-669-465-00	WASHER (1.5), STOPPER		533	3-356-927-01	SPRING (LEFT), TORSION	
513	3-356-614-01	SLIDER (BRAKE)		534	*3-356-929-01	ABSORBENT, VIBRATION	
514	3-356-601-11	SCREW, STEP		535	3-356-928-01	PLATE (A), ORNAMENTAL	
515	*X-3356-608-1	LEVER (LIFTER) ASSY		536	*3-356-742-01	BRACKET (GUIDE R)	
516	3-356-713-01	WASHER		537	7-621-772-20	SCREW +B 2X5	
517	3-356-619-01	SPRING (B), TORSION		538	3-356-659-01	SPRING (RPH), COMPRESSION	
518	3-356-710-01	SHAFT (LEFT) (CASSETTE HOLDER)		D1051	8-719-980-85	DIODE SLF-325C	
519	X-3356-648-1	SLIDER (HEAD CHASSIS V2) ASSY		HE1001	1-543-535-11	HEAD, MAGNETIC (ERASE)	
520	7-685-851-09	SCREW +BVT 2X4 (S)		HRP10011-543-733-11	(K620)...HEAD, MAGNETIC(RECORD/PLAYBACK)		
521	3-712-786-01	DAMPER, OIL		HRP10011-543-734-11	(K650ES)...HEAD, MAGNETIC(RECORD/PLAYBACK)		
522	3-356-626-01	SPRING, TENSION					

(4) MECHANISM SECTION (K620: TCM-200V2)  
(K650: TCM-200V3)

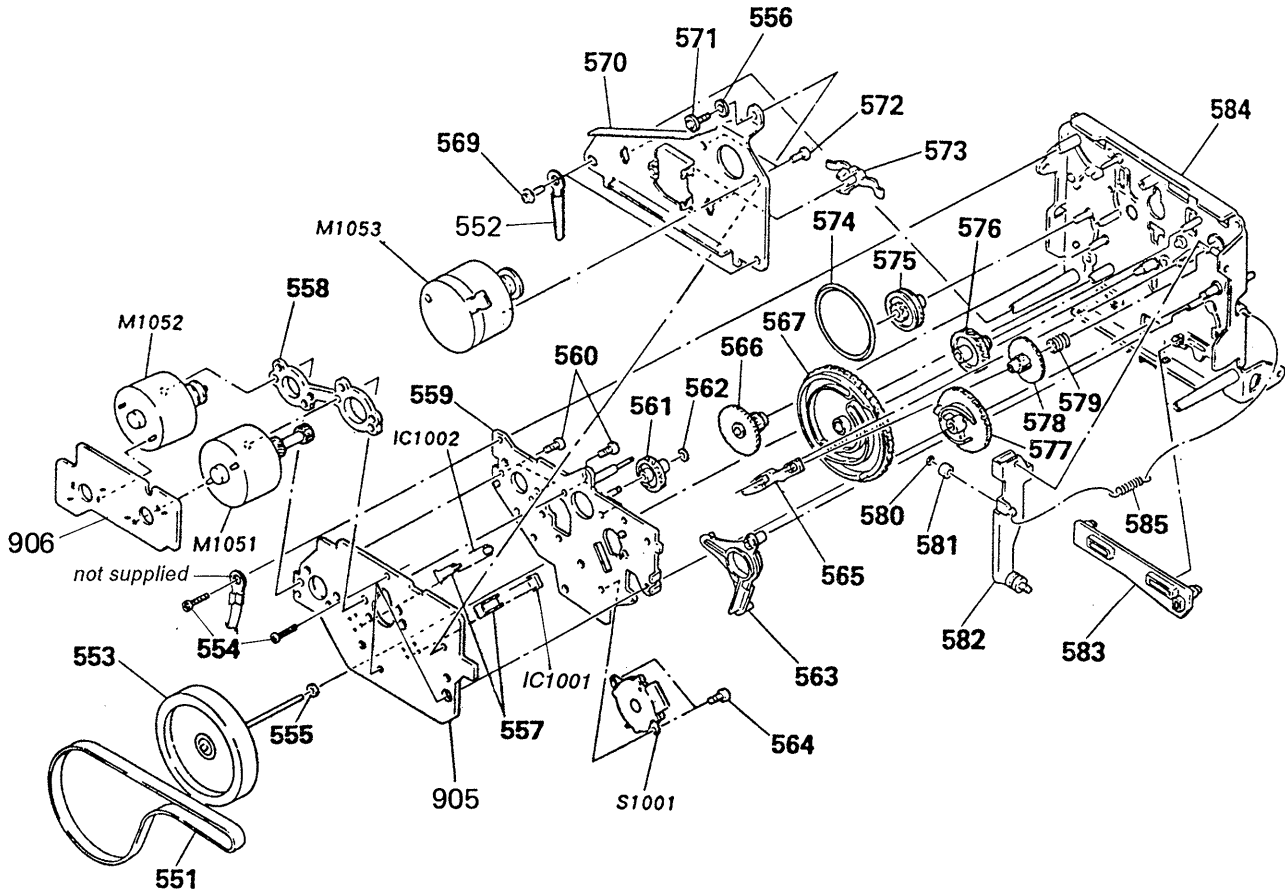

No.	Part No.	Description	Remarks	No.	Part No.	Description	Remarks
551	3-356-744-01	BELT (CAPSTAN V)		573	3-575-321-00	RETAINER, THRUST, CAPSTAN	
552	*3-701-822-00	HOLDER, WIRE		574	3-356-603-01	BELT (MODE)	
553	X-3356-642-1	FLYWHEEL (R FWD) ASSY		575	3-356-607-01	PULLEY (MODE)	
554	3-355-801-01	SCREW (BTP 2X18)		576	3-356-703-01	GEAR (COMMUNICATION C)	
555	3-356-705-01	WASHER (CAPSTAN)		577	3-356-616-01	GEAR (LOADING CAM)	
556	*3-356-718-01	SPACER (THRUST RETAINER R)		578	3-356-609-01	GEAR (LOADING)	
557	3-356-631-01	HOLDER (SENSOR)		579	3-356-605-01	SPRING, COMPRESSION	
558	*3-356-628-01	SPACER (MOTOR)		580	3-558-708-11	WASHER, STOPPER	
559	*X-3356-602-4	BRACKET (MOTOR R) ASSY		581	3-356-630-01	ROLLER (LOADING)	
560	7-621-773-95	SCREW +B 2.6X6		582	*X-3356-606-1	LEVER (LOADING) ASSY	
561	3-356-702-01	GEAR (COMMUNICATION B)		583	3-356-653-01	SLIDER (PAUSE)	
562	3-669-465-00	WASHER (1.5), STOPPER		584	X-3356-644-1	CHASSIS COMPLETE ASSY, MECH	
563	3-356-613-01	LEVER (MODE)		585	3-356-624-01	SPRING, TENSION	
564	7-621-772-20	SCREW +B 2X5		905	*1-632-740-11	PC BOARD, MD	
565	3-356-617-01	LEVER (SELECTION)		906	*1-632-741-11	PC BOARD, REEL MOTOR	
566	3-356-606-01	GEAR (MODE)		IC1001	8-749-920-97	PHOTO REFLECTOR GP2S22B	
567	3-356-747-01	GEAR (MODE CAM C)		IC1002	8-749-920-97	PHOTO REFLECTOR GP2S22B	
569	7-685-132-19	SCREW +BTP 2.6X5 TYPE2 N-S		M1051	X-3356-638-1	MOTOR (REEL R) ASSY	
570	*3-356-629-01	BRACKET (THRUST RETAINER R)		M1052	X-3356-604-1	MOTOR (ASSIST) ASSY	
571	3-356-707-01	SCREW (+PTPWH 2X25)		M1053	X-3356-646-1	MOTOR (CAPSTAN V1) ASSY	
572	7-621-775-00	SCREW +B 2.6X3		S1001	1-466-238-11	ENCODER, ROTARY	

## SECTION 6 ELECTRICAL PARTS LIST

**NOTE:**

- Due to standardization, replacements in the parts list may be different from the parts specified in the diagrams or the components used on the set.
- Items marked "★" are not stocked since they are seldom required for routine service. Some delay should be anticipated when ordering these items.
- If there are two or more same circuits in a set such as a stereophonic machine, only typical circuit parts may be indicated and capacitors and resistors in other same circuits may be omitted.

**CAPACITORS:**

MF:  $\mu$ F, PF:  $\mu$ F.

**RESISTORS**

- All resistors are in ohms.
- F: nonflammable

**COILS**

- MMH: mH, UH:  $\mu$ H

**SEMICONDUCTORS**

In each case, U:  $\mu$ , for example:  
 UA...:  $\mu$ A..., UPA...:  $\mu$ PA...,  
 UPC...:  $\mu$ PC, UPD...:  $\mu$ PD...

The components identified by mark  $\Delta$  or dotted line with mark  $\Delta$  are critical for safety. Replace only with part number specified.

Les composants identifiés par une marque  $\Delta$  sont critiques pour la sécurité. Ne les remplacer que par une pièce portant le numéro spécifié.

- WG: West Germany model

Ref.No.	Part No.	Description	Ref.No.	Part No.	Description			
901	*1-635-796-11	PC BOARD, PANEL	C201	1-126-059-11	ELECT	10MF	20%	50V
902	*A-2006-271-A	(K620)....MOUNTED PCB, SYSTEM CONTROL	C202	1-130-475-00	MYLAR	0.0022MF	5%	50V
	*A-2006-273-A	(K650ES)...MOUNTED PCB, SYSTEM CONTROL	C203	1-130-475-00	MYLAR	0.0022MF	5%	50V
903	$\Delta$ 1-551-188-XX	(E).....CORD, POWER	C204	1-130-475-00	MYLAR	0.0022MF	5%	50V
	$\Delta$ 1-551-506-XX	(US,Canadian)...CORD, POWER	C205	1-136-174-00	FILM	0.56MF	5%	50V
	$\Delta$ 1-555-795-00	(K620:AEP,WG)...CORD, POWER, EULO PLUG	C206	1-136-171-00	FILM	0.33MF	5%	50V
	$\Delta$ 1-556-035-00	(UK).....CORD, POWER	C207	1-126-059-11	ELECT	10MF	20%	50V
904	1-569-007-11	(E)...ADAPTER, CONVERSION 2P	C208	1-124-657-00	ELECT	10MF	20%	50V
905	*1-632-740-11	PC BOARD, MD	C221	1-110-335-11	(K650ES)...MYLAR	100PF	5%	50V
906	*1-632-741-11	PC BOARD, REAL MOTOR	C221	1-110-340-11	(K620)....MYLAR	270PF	5%	50V
C101	1-126-059-11	ELECT	C222	1-162-282-31	CERAMIC	100PF	10%	50V
C102	1-130-475-00	MYLAR	C223	1-136-157-00	FILM	0.022MF	5%	50V
C103	1-130-475-00	MYLAR	C224	1-124-657-00	ELECT	10MF	20%	50V
C104	1-130-475-00	MYLAR	C225	1-136-158-00	FILM	0.027MF	5%	50V
C105	1-136-174-00	FILM	C226	1-130-474-00	MYLAR	0.0018MF	5%	50V
C106	1-136-171-00	FILM	C227	1-102-963-00	CERAMIC	33PF	5%	50V
C107	1-126-059-11	ELECT	C228	1-130-474-00	MYLAR	0.0018MF	5%	50V
C108	1-124-657-00	ELECT	C231	1-130-475-00	MYLAR	0.0022MF	5%	50V
C121	1-110-335-11	(K650ES)...MYLAR 100PF	C232	1-130-475-00	MYLAR	0.0022MF	5%	50V
C121	1-110-340-11	(K620)....MYLAR 270PF	C233	1-136-174-00	FILM	0.56MF	5%	50V
C122	1-162-282-31	CERAMIC	C234	1-136-171-00	FILM	0.33MF	5%	50V
C123	1-136-157-00	FILM	C235	1-124-657-00	ELECT	10MF	20%	50V
C124	1-124-657-00	ELECT	C241	1-126-044-11	ELECT	1MF	20%	50V
C125	1-136-158-00	FILM	C242	1-126-059-11	ELECT	10MF	20%	50V
C126	1-130-474-00	MYLAR	C243	1-126-059-11	ELECT	10MF	20%	50V
C127	1-102-963-00	CERAMIC	C244	1-110-338-51	MYLAR	180PF	5%	50V
C128	1-130-474-00	MYLAR	C245	1-136-935-11	FILM	22PF	5%	630V
C131	1-130-475-00	MYLAR	C261	1-123-382-00	ELECT	3.3MF	20%	50V
C132	1-130-475-00	MYLAR	C281	1-136-153-00	FILM	0.01MF	5%	50V
C133	1-136-174-00	FILM	C282	1-136-157-00	FILM	0.022MF	5%	50V
C134	1-136-171-00	FILM	C283	1-136-165-00	FILM	0.1MF	5%	50V
C135	1-124-657-00	ELECT	C284	1-136-803-11	FILM	560PF	5%	630V
C141	1-126-044-11	ELECT	C285	1-136-433-11	FILM	100PF	5%	630V
C142	1-126-059-11	ELECT	C286	1-130-468-00	MYLAR	560PF	5%	50V
C143	1-126-059-11	ELECT	C501	1-126-022-11	ELECT	47MF	20%	25V
C144	1-110-338-51	MYLAR	C502	1-126-022-11	ELECT	47MF	20%	25V
C145	1-136-935-11	FILM	C503	1-126-044-11	ELECT	1MF	20%	50V
C161	1-123-382-00	ELECT	C521	1-124-994-11	ELECT	100MF	20%	10V
C181	1-136-153-00	FILM	C522	1-124-994-11	ELECT	100MF	20%	10V
C182	1-136-157-00	FILM	C531	1-126-022-11	ELECT	47MF	20%	25V
C183	1-136-165-00	FILM	C532	1-126-022-11	ELECT	47MF	20%	25V
C184	1-136-803-11	FILM	C541	1-126-044-11	ELECT	1MF	20%	50V
C185	1-136-433-11	FILM	C551	1-123-875-11	ELECT	10MF	20%	50V
C186	1-130-468-00	MYLAR	C552	1-123-875-11	ELECT	10MF	20%	50V
			C563	1-162-217-31	CERAMIC	56PF	5%	50V
			C564	1-136-157-00	FILM	0.022MF	5%	50V

Ref.No.	Part No.	Description			
C566	1-162-217-31	CERAMIC	56PF	5%	50V
C567	1-124-927-11	ELECT	4.7MF	20%	50V
C568	1-124-925-11	ELECT	2.2MF	20%	50V
C583	1-126-043-11	ELECT	0.47MF	20%	50V
C584	1-126-022-11	ELECT	47MF	20%	25V
C585	1-126-022-11	ELECT	47MF	20%	25V
C586	1-136-253-11	FILM	0.0018MF	5%	100V
C587	1-136-253-11	FILM	0.0018MF	5%	100V
C588	1-136-233-11	FILM	0.0047MF	5%	100V
C589	1-161-494-00	CERAMIC	0.022MF		25V
C590	1-126-049-11	ELECT	22MF	20%	50V
C591	1-107-045-00	MICA	3.9PF	0.5PF	500V
C592	1-136-558-11	FILM	0.0039MF	5%	630V
C701	1-162-294-31	CERAMIC	0.001MF	10%	50V
C702	1-162-294-31	CERAMIC	0.001MF	10%	50V
C703	1-164-159-11	CERAMIC	0.1MF		50V
C704	1-164-159-11	CERAMIC	0.1MF		50V
C705	1-164-159-11	CERAMIC	0.1MF		50V
C706	1-124-477-11	ELECT	47MF	20%	25V
C707	1-126-176-11	ELECT	220MF	20%	10V
C708	1-124-477-11	ELECT	47MF	20%	25V
C709	1-123-875-11	ELECT	10MF	20%	50V
C710	1-164-159-11	CERAMIC	0.1MF		50V
C753	1-124-589-11	ELECT	47MF	20%	16V
C803	1-124-556-11	ELECT	2200MF	20%	16V
C804	1-124-556-11	ELECT	2200MF	20%	16V
C806	1-126-022-11	ELECT	47MF	20%	25V
C808	1-124-999-11	ELECT	2200MF	20%	10V
C809	1-124-999-11	ELECT	2200MF	20%	10V
C810	1-124-927-11	ELECT	4.7MF	20%	50V
C811	1-126-936-11	ELECT	3300MF	20%	16V
C813	1-123-875-11	ELECT	10MF	20%	50V
C814	1-124-471-00	ELECT	1000MF	20%	6.3V
C815	1-124-564-11	ELECT	4700MF	20%	25V
C816	1-123-875-11	ELECT	10MF	20%	50V
C817	1-124-360-00	ELECT	1000MF	20%	16V
C818	1-124-122-11	ELECT	100MF	20%	50V
C819	1-124-910-11	ELECT	47MF	20%	35V
C820	1-164-159-11	CERAMIC	0.1MF		50V
C1051	1-123-875-11	ELECT	10MF	20%	50V
C1052	1-123-875-11	ELECT	10MF	20%	50V
C1053	1-164-159-11	CERAMIC	0.1MF		50V
CN501	*1-564-719-11	PIN, CONNECTOR (SMALL TYPE) 3P			
CN502	*1-564-719-11	PIN, CONNECTOR (SMALL TYPE) 3P			
CN505	*1-564-707-11	PIN, CONNECTOR (SMALL TYPE) 5P			
CN1001	1-506-615-11	PIN, CONNECTOR 9P			
CN1002	1-564-501-11	PIN, CONNECTOR 8P			
CN1051	*1-564-499-11	PIN, CONNECTOR 6P			
CN1052	*1-564-718-11	PIN, CONNECTOR (SMALL TYPE) 2P			
CN1053	*1-564-718-11	PIN, CONNECTOR (SMALL TYPE) 2P			
CNP501	*1-564-705-11	PIN, CONNECTOR (SMALL TYPE) 3P			
CNP502	*1-564-705-11	PIN, CONNECTOR (SMALL TYPE) 3P			
CNP503	*1-564-337-61	PIN, CONNECTOR 3P			
CNP504	*1-564-338-00	PIN, CONNECTOR 4P			
CNP505	*1-564-707-11	PIN, CONNECTOR (SMALL TYPE) 5P			
CNP521	*1-560-062-00	PIN, CONNECTOR 4P			

Ref.No.	Part No.	Description
CNP541	*1-560-062-00	PIN, CONNECTOR 4P
CNP581	*1-560-060-00	PIN, CONNECTOR 2P
CNP582	*1-564-336-00	PIN, CONNECTOR 2P
CNP701	*1-564-338-61	PIN, CONNECTOR 4P
CNP801	*1-508-882-00	BASE POST
CNP802	*1-564-340-00	PIN, CONNECTOR 6P
D161	8-719-107-94	DIODE 1SS202-1
D261	8-719-107-94	DIODE 1SS202-1
D501	8-719-107-94	DIODE 1SS202-1
D502	8-719-107-94	DIODE 1SS202-1
D503	8-719-107-94	DIODE 1SS202-1
D541	8-719-107-94	DIODE 1SS202-1
D542	8-719-107-94	DIODE 1SS202-1
D543	8-719-107-94	DIODE 1SS202-1
D561	8-719-107-94	DIODE 1SS202-1
D582	8-719-107-94	DIODE 1SS202-1
D583	8-719-107-94	DIODE 1SS202-1
D584	8-719-107-94	DIODE 1SS202-1
D701	8-719-107-94	DIODE 1SS202-1
D702	8-719-107-94	DIODE 1SS202-1
D703	8-719-107-94	DIODE 1SS202-1
D704	8-719-107-94	DIODE 1SS202-1
D705	8-719-107-94	DIODE 1SS202-1
D706	8-719-107-94	DIODE 1SS202-1
D707	8-719-200-77	DIODE 10E2N
D710	8-719-107-94	DIODE 1SS202-1
D711	8-719-107-94	DIODE 1SS202-1
D752	8-719-107-94	DIODE 1SS202-1
D753	8-719-107-94	DIODE 1SS202-1
D754	8-719-107-94	DIODE 1SS202-1
D755	8-719-107-94	DIODE 1SS202-1
D801	8-719-200-77	DIODE 10E2N
D802	8-719-200-77	DIODE 10E2N
D803	8-719-200-77	DIODE 10E2N
D804	8-719-200-77	DIODE 10E2N
D805	8-719-933-33	DIODE HZS6A1L
D806	8-719-933-33	DIODE HZS6A1L
D807	8-719-107-94	DIODE 1SS202-1
D808	8-719-200-77	DIODE 10E2N
D809	8-719-200-77	DIODE 10E2N
D810	8-719-200-77	DIODE 10E2N
D811	8-719-200-77	DIODE 10E2N
D812	8-719-107-94	DIODE 1SS202-1
D813	8-719-200-77	DIODE 10E2N
D814	8-719-933-36	DIODE HZS6B1L
D815	8-719-107-94	DIODE 1SS202-1
D816	8-719-107-94	DIODE 1SS202-1
D817	8-719-001-70	DIODE UZL-12M1
D818	8-719-200-77	DIODE 10E2N
D819	8-719-200-77	DIODE 10E2N
D820	8-719-000-93	DIODE UZL-7H1
D822	8-719-107-94	DIODE 1SS202-1
D1051	8-719-980-85	DIODE SLF-325C
FL751	1-519-596-11	INDICATOR TUBE, FLUORESCENT
HE1001	1-543-535-11	HEAD, MAGNETIC (ERASE)

Ref.No.	Part No.	Description	Ref.No.	Part No.	Description
HRP1001	1-543-733-11	(K620)...HEAD, MAGNETIC (RECORD/PLAYBACK)	Q703	8-729-900-61	TRANSISTOR DTA114ES
HRP1001	1-543-734-11	(K650ES)...HEAD, MAGNETIC (RECORD/PLAYBACK)	Q704	8-729-900-61	TRANSISTOR DTA114ES
IC501	8-752-036-34	IC CXA1330S	Q705	8-729-119-76	TRANSISTOR 2SA1175-HFE
IC502	8-759-208-14	IC TC4066BPHB	Q706	8-729-119-76	TRANSISTOR 2SA1175-HFE
IC521	8-759-111-44	IC UPC4570C-1	Q707	8-729-900-61	TRANSISTOR DTA114ES
IC531	8-752-036-34	IC CXA1330S	Q708	8-729-900-61	TRANSISTOR DTA114ES
IC541	8-752-038-02	IC CXA1198AP	Q709	8-729-620-05	TRANSISTOR 2SC2603-EF
IC551	8-759-634-51	IC M5218AP	Q710	8-729-900-80	TRANSISTOR DTC114ES
IC561	8-759-945-58	IC RC4558P	Q711	8-729-900-65	TRANSISTOR DTA144ES
IC562	8-759-945-58	IC RC4558P	Q712	8-729-900-80	TRANSISTOR DTC114ES
IC581	8-759-106-56	IC UPC1297CA	Q713	8-729-900-65	TRANSISTOR DTA144ES
IC701	8-759-634-99	IC M50941-354SP	Q714	8-729-620-05	TRANSISTOR 2SC2603-EF
IC702	8-759-240-69	IC TC4069UBP	Q715	8-729-900-89	TRANSISTOR DTC144ES
IC703	8-759-973-95	IC BA6219B	Q716	8-729-900-89	TRANSISTOR DTC144ES
IC704	8-759-822-09	IC LB1641	Q751	8-729-900-61	TRANSISTOR DTA114ES
IC751	8-741-100-48	IC SBX1610-59	Q753	8-729-900-61	TRANSISTOR DTA114ES
IC801	8-759-945-58	IC RC4558P	Q754	8-729-900-61	TRANSISTOR DTA114ES
IC1001	8-749-920-97	PHOTO REFLECTOR GP2S22B	Q755	8-729-900-61	TRANSISTOR DTA114ES
IC1002	8-749-920-97	PHOTO REFLECTOR GP2S22B	Q756	8-729-900-61	TRANSISTOR DTA114ES
J501	*1-568-069-11	JACK, PIN 4P (LINE IN/OUT)	Q757	8-729-900-61	TRANSISTOR DTA114ES
J551	1-507-796-71	JACK (PHONES)	Q758	8-729-900-61	TRANSISTOR DTA114ES
L121	1-410-778-11	INDUCTOR 18MMH	Q801	8-729-900-61	TRANSISTOR DTA114ES
L141	1-410-780-11	INDUCTOR 27MMH	Q802	8-729-900-80	TRANSISTOR DTC114ES
L221	1-410-778-11	INDUCTOR 18MMH	Q803	8-729-920-97	TRANSISTOR 2SB1187-EF
L241	1-410-780-11	INDUCTOR 27MMH	Q804	8-729-920-98	TRANSISTOR 2SD1761-EF
LPF101	1-236-147-11	FILTER, LOW PASS	Q805	8-729-920-98	TRANSISTOR 2SD1761-EF
LPF201	1-236-147-11	FILTER, LOW PASS	Q806	8-729-620-05	TRANSISTOR 2SC2603-EF
M1051	X-3356-638-1	MOTOR (REEL R) ASSY	Q807	8-729-900-80	TRANSISTOR DTC114ES
M1052	X-3356-604-1	MOTOR (ASSIST) ASSY	Q808	8-729-920-97	TRANSISTOR 2SB1187-EF
M1053	X-3356-646-1	MOTOR (CAPSTAN V1) ASSY	Q809	8-729-620-05	TRANSISTOR 2SC2603-EF
Q101	8-729-900-80	TRANSISTOR DTC114ES	Q810	8-729-119-76	TRANSISTOR 2SA1175-HFE
Q102	8-729-620-05	TRANSISTOR 2SC2603-EF	Q811	8-729-140-04	TRANSISTOR 2SB1116A-L
Q121	8-729-900-74	TRANSISTOR DTC143TS	R101	1-259-460-11	CARBON 22K 5% 1/6W
Q141	8-729-620-05	TRANSISTOR 2SC2603-EF	R102	1-259-484-11	CARBON 220K 5% 1/6W
Q201	8-729-900-80	TRANSISTOR DTC114ES	R103	1-249-429-11	CARBON 10K 5% 1/4W
Q202	8-729-620-05	TRANSISTOR 2SC2603-EF	R104	1-259-440-11	CARBON 3.3K 5% 1/6W
Q221	8-729-900-74	TRANSISTOR DTC143TS	R105	1-259-450-11	CARBON 8.2K 5% 1/6W
Q241	8-729-620-05	TRANSISTOR 2SC2603-EF	R106	1-259-461-11	CARBON 24K 5% 1/6W
Q501	8-729-900-65	TRANSISTOR DTA144ES	R107	1-259-422-11	CARBON 560 5% 1/6W
Q502	8-729-900-89	TRANSISTOR DTC144ES	R108	1-259-476-11	CARBON 100K 5% 1/6W
Q503	8-729-900-65	TRANSISTOR DTA144ES	R109	1-259-436-11	CARBON 2.2K 5% 1/6W
Q504	8-729-900-80	TRANSISTOR DTC114ES	R110	1-249-421-11	CARBON 2.2K 5% 1/4W
Q541	8-729-900-74	TRANSISTOR DTC143TS	R111	1-259-452-11	CARBON 10K 5% 1/6W
Q542	8-729-900-74	TRANSISTOR DTC143TS	R112	1-259-428-11	CARBON 1K 5% 1/6W
Q543	8-729-900-74	TRANSISTOR DTC143TS	R121	1-259-466-11	(K650ES)...CARBON 39K 5% 1/6W
Q561	8-729-119-76	TRANSISTOR 2SA1175-HFE	R121	1-259-476-11	(K620).....CARBON 100K 5% 1/6W
Q581	8-729-119-76	TRANSISTOR 2SA1175-HFE	R122	1-249-782-11	(K620).....CARBON 150 5% 1/6W
Q582	8-729-900-80	TRANSISTOR DTC114ES	R122	1-259-404-11	(K650ES)...CARBON 100 5% 1/6W
Q583	8-729-900-80	TRANSISTOR DTC114ES	R123	1-259-479-11	CARBON 130K 5% 1/6W
Q584	8-729-900-80	TRANSISTOR DTC114ES	R124	1-259-446-11	CARBON 5.6K 5% 1/6W
Q585	8-729-194-57	TRANSISTOR 2SC945-QP	R125	1-259-434-11	CARBON 1.8K 5% 1/6W
Q586	8-729-194-57	TRANSISTOR 2SC945-QP	R126	1-259-435-11	CARBON 2K 5% 1/6W
Q701	8-729-900-61	TRANSISTOR DTA114ES	R127	1-259-484-11	CARBON 220K 5% 1/6W
Q702	8-729-900-61	TRANSISTOR DTA114ES	R131	1-249-429-11	CARBON 10K 5% 1/4W

Ref.No.	Part No.	Description			
R132	1-249-429-11	CARBON	10K	5%	1/4W
R133	1-249-429-11	CARBON	10K	5%	1/4W
R134	1-259-461-11	CARBON	24K	5%	1/6W
R135	1-259-422-11	CARBON	560	5%	1/6W
R136	1-259-452-11	CARBON	10K	5%	1/6W
R137	1-259-476-11	CARBON	100K	5%	1/6W
R141	1-259-446-11	CARBON	5.6K	5%	1/6W
R142	1-259-437-11	CARBON	2.4K	5%	1/6W
R143	1-259-436-11	CARBON	2.2K	5%	1/6W
R144	1-259-452-11	CARBON	10K	5%	1/6W
R145	1-249-421-11	CARBON	2.2K	5%	1/4W
R146	1-249-425-11	CARBON	4.7K	5%	1/4W
R151	1-249-433-11	CARBON	22K	5%	1/4W
R152	1-249-421-11	CARBON	2.2K	5%	1/4W
R153	1-247-862-11	CARBON	20K	5%	1/4W
R154	1-249-409-11	CARBON	220	5%	1/4W
R161	1-249-434-11	CARBON	27K	5%	1/4W
R162	1-249-434-11	CARBON	27K	5%	1/4W
R163	1-247-862-11	CARBON	20K	5%	1/4W
R164	1-249-409-11	CARBON	220	5%	1/4W
R181	1-249-432-11	CARBON	18K	5%	1/4W
R182	1-249-435-11	CARBON	33K	5%	1/4W
R183	1-249-393-11	CARBON	10	5%	1/4W
R184	1-247-883-00	CARBON	150K	5%	1/4W
R201	1-259-460-11	CARBON	22K	5%	1/6W
R202	1-259-484-11	CARBON	220K	5%	1/6W
R203	1-249-429-11	CARBON	10K	5%	1/4W
R204	1-259-440-11	CARBON	3.3K	5%	1/6W
R205	1-259-450-11	CARBON	8.2K	5%	1/6W
R206	1-259-461-11	CARBON	24K	5%	1/6W
R207	1-259-422-11	CARBON	560	5%	1/6W
R208	1-259-476-11	CARBON	100K	5%	1/6W
R209	1-259-436-11	CARBON	2.2K	5%	1/6W
R210	1-249-421-11	CARBON	2.2K	5%	1/4W
R211	1-259-452-11	CARBON	10K	5%	1/6W
R212	1-259-428-11	CARBON	1K	5%	1/6W
R221	1-259-466-11	(K650ES)...CARBON	39K	5%	1/6W
R221	1-259-476-11	(K620)....CARBON	100K	5%	1/6W
R222	1-249-782-11	(K620)....CARBON	150	5%	1/6W
R222	1-259-404-11	(K650ES)...CARBON	100	5%	1/6W
R223	1-259-479-11	CARBON	130K	5%	1/6W
R224	1-259-446-11	CARBON	5.6K	5%	1/6W
R225	1-259-434-11	CARBON	1.8K	5%	1/6W
R226	1-259-435-11	CARBON	2K	5%	1/6W
R227	1-259-484-11	CARBON	220K	5%	1/6W
R231	1-249-429-11	CARBON	10K	5%	1/4W
R232	1-249-429-11	CARBON	10K	5%	1/4W
R233	1-249-429-11	CARBON	10K	5%	1/4W
R234	1-259-461-11	CARBON	24K	5%	1/6W
R235	1-259-422-11	CARBON	560	5%	1/6W
R236	1-259-452-11	CARBON	10K	5%	1/6W
R237	1-259-476-11	CARBON	100K	5%	1/6W
R241	1-259-446-11	CARBON	5.6K	5%	1/6W
R242	1-259-437-11	CARBON	2.4K	5%	1/6W
R243	1-259-436-11	CARBON	2.2K	5%	1/6W

Ref.No.	Part No.	Description			
R244	1-259-452-11	CARBON	10K	5%	1/6W
R245	1-249-421-11	CARBON	2.2K	5%	1/4W
R246	1-249-425-11	CARBON	4.7K	5%	1/4W
R251	1-249-433-11	CARBON	22K	5%	1/4W
R252	1-249-421-11	CARBON	2.2K	5%	1/4W
R253	1-247-862-11	CARBON	20K	5%	1/4W
R254	1-249-409-11	CARBON	220	5%	1/4W
R261	1-249-434-11	CARBON	27K	5%	1/4W
R262	1-249-434-11	CARBON	27K	5%	1/4W
R263	1-247-862-11	CARBON	20K	5%	1/4W
R264	1-249-409-11	CARBON	220	5%	1/4W
R281	1-249-432-11	CARBON	18K	5%	1/4W
R282	1-249-435-11	CARBON	33K	5%	1/4W
R283	1-249-393-11	CARBON	10	5%	1/4W
R284	1-247-883-00	CARBON	150K	5%	1/4W
R501	1-259-428-11	CARBON	1K	5%	1/6W
R502	1-215-455-00	METAL	27K	1%	1/6W
R503	1-249-433-11	CARBON	22K	5%	1/4W
R504	1-249-433-11	CARBON	22K	5%	1/4W
R521	1-247-704-11	CARBON	220	5%	1/4W
R522	1-247-704-11	CARBON	220	5%	1/4W
R531	1-259-428-11	CARBON	1K	5%	1/6W
R532	1-215-455-00	METAL	27K	1%	1/6W
R533	1-249-437-11	CARBON	47K	5%	1/4W
R541	1-249-441-11	CARBON	100K	5%	1/4W
R543	1-215-454-00	METAL	24K	1%	1/6W
R563	1-249-441-11	CARBON	100K	5%	1/4W
R564	1-249-429-11	CARBON	10K	5%	1/4W
R565	1-249-441-11	CARBON	100K	5%	1/4W
R566	1-249-428-11	CARBON	8.2K	5%	1/4W
R567	1-249-441-11	CARBON	100K	5%	1/4W
R568	1-249-423-11	CARBON	3.3K	5%	1/4W
R569	1-249-441-11	CARBON	100K	5%	1/4W
R570	1-249-429-11	CARBON	10K	5%	1/4W
R571	1-249-429-11	CARBON	10K	5%	1/4W
R572	1-249-417-11	CARBON	1K	5%	1/4W
R581	1-249-429-11	CARBON	10K	5%	1/4W
R582	1-249-429-11	CARBON	10K	5%	1/4W
R583	1-249-420-11	(K620)....CARBON	1.8K	5%	1/4W
R583	1-249-422-11	(K650ES)...CARBON	2.7K	5%	1/4W
R584	1-247-846-11	(K620)....CARBON	4.3K	5%	1/4W
R584	1-247-850-11	(K650ES)...CARBON	6.2K	5%	1/4W
R585	1-249-437-11	CARBON	47K	5%	1/4W
R586	1-249-424-11	(K620)....CARBON	3.9K	5%	1/4W
R586	1-249-425-11	(K650ES)...CARBON	4.7K	5%	1/4W
R587	1-249-440-11	CARBON	82K	5%	1/4W
R588	1-249-440-11	CARBON	82K	5%	1/4W
R589	1-249-390-11	CARBON	5.6	5%	1/4W
R590	1-249-390-11	CARBON	5.6	5%	1/4W
R591	1-249-435-11	CARBON	33K	5%	1/4W
R592	1-249-423-11	CARBON	3.3K	5%	1/4W
R601	1-247-876-11	(K620)....CARBON	75K	5%	1/4W
R601	1-249-439-11	(K650ES)...CARBON	68K	5%	1/4W
R602	1-249-435-11	CARBON	33K	5%	1/4W
R603	-247-870-11	CARBON	43K	5%	1/4W

Ref.No.	Part No.	Description				
R604	1-249-439-11	(K620)....CARBON	68K	5%	1/4W	
R604	1-249-441-11	(K650ES)...CARBON	100K	5%	1/4W	
R605	1-249-874-11	(K650ES)...CARBON	62K	5%	1/4W	
R605	1-247-878-00	(K620)....CARBON	91K	5%	1/4W	
R606	1-249-433-11	(K620)....CARBON	22K	5%	1/4W	
R606	1-249-434-11	(K650ES)...CARBON	27K	5%	1/4W	
R607	1-249-439-11	CARBON	68K	5%	1/4W	
R608	1-249-437-11	CARBON	47K	5%	1/4W	
R609	1-249-441-11	CARBON	100K	5%	1/4W	
R610	1-247-880-11	(K650ES)...CARBON	110K	5%	1/4W	
R610	1-249-439-11	(K620)....CARBON	68K	5%	1/4W	
R611	1-247-874-11	(K650ES)...CARBON	62K	5%	1/4W	
R611	1-247-878-00	(K620)....CARBON	91K	5%	1/4W	
R612	1-247-887-00	CARBON	220K	5%	1/4W	
R613	1-247-876-11	CARBON	75K	5%	1/4W	
R614	1-247-872-11	CARBON	51K	5%	1/4W	
R615	1-247-874-11	(K650ES)...CARBON	62K	5%	1/4W	
R615	1-247-886-11	(K620)....CARBON	200K	5%	1/4W	
R616	1-249-439-11	CARBON	68K	5%	1/4W	
R617	1-249-439-11	(K620)....CARBON	68K	5%	1/4W	
R617	1-249-441-11	(K650ES)...CARBON	100K	5%	1/4W	
R618	1-247-885-00	(K650ES)...CARBON	180K	5%	1/4W	
R618	1-247-888-11	(K620)....CARBON	240K	5%	1/4W	
R701	1-247-887-00	CARBON	220K	5%	1/4W	
R702	1-247-887-00	CARBON	220K	5%	1/4W	
R703	1-249-436-11	CARBON	39K	5%	1/4W	
R704	1-247-887-00	CARBON	220K	5%	1/4W	
R705	1-249-436-11	CARBON	39K	5%	1/4W	
R706	1-247-887-00	CARBON	220K	5%	1/4W	
R707	1-249-430-11	CARBON	12K	5%	1/4W	
R708	1-249-435-11	CARBON	33K	5%	1/4W	
R709	1-249-435-11	CARBON	33K	5%	1/4W	
R710	1-249-435-11	CARBON	33K	5%	1/4W	
R711	1-247-872-11	CARBON	51K	5%	1/4W	
R712	1-249-435-11	CARBON	33K	5%	1/4W	
R713	1-249-435-11	CARBON	33K	5%	1/4W	
R714	1-249-435-11	CARBON	33K	5%	1/4W	
R715	1-249-435-11	CARBON	33K	5%	1/4W	
R720	Δ.1-212-954-11	FUSIBLE	6.8	5%	1/2W	F
R721	1-249-429-11	CARBON	10K	5%	1/4W	
R722	1-249-431-11	CARBON	15K	5%	1/4W	
R723	1-249-421-11	CARBON	2.2K	5%	1/4W	
R724	1-249-424-11	CARBON	3.9K	5%	1/4W	
R725	1-247-834-11	CARBON	1.3K	5%	1/4W	
R726	1-249-427-11	CARBON	6.8K	5%	1/4W	
R727	1-249-430-11	CARBON	12K	5%	1/4W	
R728	Δ.1-212-952-00	FUSIBLE	5.6	5%	1/2W	F
R729	1-249-435-11	CARBON	33K	5%	1/4W	
R730	1-249-435-11	CARBON	33K	5%	1/4W	
R731	1-249-425-11	CARBON	4.7K	5%	1/4W	
R732	1-249-417-11	CARBON	1K	5%	1/4W	
R733	1-247-903-00	CARBON	1M	5%	1/4W	
R751	1-249-421-11	CARBON	2.2K	5%	1/4W	
R752	1-249-441-11	CARBON	100K	5%	1/4W	
R753	1-249-441-11	CARBON	100K	5%	1/4W	
R754	1-249-441-11	CARBON	100K	5%	1/4W	

Ref.No.	Part No.	Description				
R755	1-249-441-11	CARBON	100K	5%	1/4W	
R756	1-249-441-11	CARBON	100K	5%	1/4W	
R757	1-249-441-11	CARBON	100K	5%	1/4W	
R758	1-249-441-11	CARBON	100K	5%	1/4W	
R759	1-249-422-11	CARBON	2.7K	5%	1/4W	
R760	1-249-424-11	CARBON	3.9K	5%	1/4W	
R761	1-249-428-11	CARBON	8.2K	5%	1/4W	
R762	1-249-434-11	CARBON	27K	5%	1/4W	
R763	1-249-422-11	CARBON	2.7K	5%	1/4W	
R764	1-249-424-11	CARBON	3.9K	5%	1/4W	
R766	1-249-422-11	CARBON	2.7K	5%	1/4W	
R767	1-249-424-11	CARBON	3.9K	5%	1/4W	
R768	1-249-428-11	CARBON	8.2K	5%	1/4W	
R770	1-249-429-11	CARBON	10K	5%	1/4W	
R771	1-249-429-11	CARBON	10K	5%	1/4W	
R772	1-249-429-11	CARBON	10K	5%	1/4W	
R773	1-249-429-11	CARBON	10K	5%	1/4W	
R774	1-249-422-11	CARBON	2.7K	5%	1/4W	
R775	1-249-424-11	CARBON	3.9K	5%	1/4W	
R776	1-249-421-11	CARBON	2.2K	5%	1/4W	
R777	1-249-441-11	CARBON	100K	5%	1/4W	
R802	1-259-444-11	CARBON	4.7K	5%	1/6W	
R803	1-259-434-11	CARBON	1.8K	5%	1/6W	
R804	1-259-418-11	CARBON	390	5%	1/6W	
R805	1-259-448-11	CARBON	6.8K	5%	1/6W	
R806	1-259-432-11	CARBON	1.5K	5%	1/6W	
R807	1-259-452-11	CARBON	10K	5%	1/6W	
R808	1-259-432-11	CARBON	1.5K	5%	1/6W	
R809	1-259-444-11	CARBON	4.7K	5%	1/6W	
R810	1-249-409-11	CARBON	220	5%	1/4W	
R811	1-259-428-11	CARBON	1K	5%	1/6W	
R812	1-259-448-11	CARBON	6.8K	5%	1/6W	
R813	1-259-448-11	CARBON	6.8K	5%	1/6W	
R814	1-249-417-11	CARBON	1K	5%	1/4W	
R815	1-249-425-11	CARBON	4.7K	5%	1/4W	
R816	1-249-421-11	CARBON	2.2K	5%	1/4W	
R817	1-249-425-11	CARBON	4.7K	5%	1/4W	
R818	1-249-433-11	CARBON	22K	5%	1/4W	
R819	1-249-436-11	CARBON	39K	5%	1/4W	
R820	1-249-428-11	CARBON	8.2K	5%	1/4W	
R821	1-249-437-11	CARBON	47K	5%	1/4W	
R822	Δ.1-219-135-11	FUSIBLE	0.15	10%	1/4W	F
R823	Δ.1-219-135-11	FUSIBLE	0.15	10%	1/4W	F
R1001	1-249-408-11	CARBON	180	5%	1/4W	
R1002	1-249-408-11	CARBON	180	5%	1/4W	
R1051	1-249-414-11	CARBON	560	5%	1/4W	
RV121	1-237-459-11	RES, ADJ, CARBON	10K			
RV141	1-237-460-11	RES, ADJ, CARBON	20K			
RV181	1-238-017-11	RES, ADJ, CARBON	22K			
RV221	1-237-459-11	RES, ADJ, CARBON	10K			
RV241	1-237-460-11	RES, ADJ, CARBON	20K			
RV281	1-238-017-11	RES, ADJ, CARBON	22K			
RV501	1-241-045-12	RES, VAR, CARBON	50K/50K		(REC LEVEL)	
RV502	1-238-904-11	RES, VAR, CARBON	50K/50K		(BALANCE)	
RV551	1-241-060-11	RES, VAR, CARBON	20K/20K		(PHONE LEVEL)	
RV581	1-241-046-11	RES, VAR, CARBON	5K		(BIAS)	



<p><b>Note:</b> The components identified by mark <b>Δ</b> or dotted line with mark <b>Δ</b> are critical for safety. Replace only with part number specified.</p>	<p><b>Note:</b> Les composants identifiés par une marque <b>Δ</b> sont critiques pour la sécurité. Ne les remplacer que par une pièce portant le numéro spécifié.</p>
--	---

Ref.No.	Part No.	Description
S501	1-572-154-11	SWITCH, ROTARY (DOLBY NR)
S502	1-571-305-11	SWITCH, PUSH (1 KEY)(MPX FILTER)
S751	1-554-303-21	SWITCH, KEY BOARD (OPEN/CLOSE)
S752	1-554-303-21	SWITCH, KEY BOARD ( ■ )
S753	1-554-303-21	SWITCH, KEY BOARD ( ◀◀ )
S754	1-554-303-21	SWITCH, KEY BOARD ( ▶▶ )
S755	1-554-303-21	SWITCH, KEY BOARD (REC)
S756	1-554-303-21	SWITCH, KEY BOARD ( ▷ )
S757	1-554-303-21	SWITCH, KEY BOARD (PAUSE)
S758	1-554-303-21	SWITCH, KEY BOARD (REC MUTE)
S759	1-554-303-21	SWITCH, KEY BOARD (RESET)
S760	1-554-303-21	SWITCH, KEY BOARD (MEMORY)
S761	1-554-303-21	SWITCH, KEY BOARD (DISPLAY MODE)
S762	1-554-303-21	SWITCH, KEY BOARD (MONITOR)
S763	1-571-520-11	SWITCH, SLIDE (TIMER)
S801	1-571-305-11	SWITCH, PUSH (1 KEY)(POWER)
S1001	1-466-238-11	ENCODER, ROTARY
S1002	1-570-953-11	SWITCH, PUSH (1 KEY)(DOOR)
S1003	1-571-958-11	SWITCH, PUSH (1 KEY)(CLOSE)
S1004	1-572-126-11	SWITCH, PUSH (1 KEY)(OPEN)
S1005	1-572-125-11	SWITCH, LEAF (REC)
S1006	1-572-202-11	SWITCH, LEAF (HALF)
S1007	1-572-125-11	SWITCH, LEAF (METAL)
S1008	1-572-125-11	SWITCH, LEAF (70U)
T181	1-433-344-11	TRANSFORMER, BIAS OSCILLATION
T281	1-433-344-11	TRANSFORMER, BIAS OSCILLATION
T581	1-433-343-11	TRANSFORMER, BIAS OSCILLATION
T901	△.1-450-099-11	(AEP,WG,UK).....TRANSFORMER, POWER
T901	△.1-450-100-11	(US,Canadian)...TRANSFORMER, POWER
T901	△.1-450-101-11	(E).....TRANSFORMER, POWER
TB1001	*1-569-066-11	PIN, CONNECTOR 5P
TP581	*1-564-506-11	PLUG, CONNECTOR 3P
TP701	*1-564-505-11	PLUG, CONNECTOR 2P
X701	1-577-359-21	VIBRATOR, CERAMIC (4.19MHz)
VS901	△.1-570-307-11	(E)...SWITCH, VOLTAGE CHANGE

ACCESSORY & PACKING MATERIAL

1-559-533-11	CORD, CONNECTION
*3-350-829-81	(K650ES)...INDIVIDUAL CARTON
*3-350-829-91	(K620).....INDIVIDUAL CARTON
*3-350-830-01	CUSHION
3-703-450-01	(US)...INSTRUCTION
*3-703-710-41	STICKER, SONY SYMBOL (12)
3-751-741-11	(K620:AEP,Canadian)...MANUAL, INSTRUCTION (ENGLISH,FRENCH,SPANISH,PORTUGUESE)
3-751-741-21	(K620:US)...MANUAL, INSTRUCTION(ENGLISH)
3-751-741-41	(K620:AEP)...MANUAL, INSTRUCTION (GERMAN,DUTCH,SWEDISH,ITALIAN)
3-751-741-51	(K620:WG)...MANUAL, INSTRUCTION (GERMAN)
3-751-742-11	(K650ES:E)...MANUAL, INSTRUCTION(ENGLISH)
3-751-742-21	(K650ES:US,UK)...MANUAL, INSTRUCTION (ENGLISH,FRENCH,SPANISH)

**Note:**

The components identified by mark  or dotted line with mark  are critical for safety. Replace only with part number specified.

**Note:**

Les composants identifiés par une marque  sont critiques pour la sécurité. Ne les remplacer que par une pièce portant le numéro spécifié.