



## Service Information

### TDLR 60111

8593 352 10050

Last Modification: 01/04/16

Creation Date: 23/06/15

---

<b>Spare Part List</b>	<b>2</b>
<b>Exploded View</b>	<b>4</b>
<b>Technical Data</b>	<b>6</b>
<b>Wiring Diagram</b>	<b>8</b>
<b>Circuit Diagram</b>	<b>10</b>
<b>Program Chart</b>	<b>12</b>
<b>Testprogram</b>	<b>27</b>
<b>Error Codes</b>	<b>28</b>

---

This document is only intended for qualified technicians who are aware of the respective safety regulations.  
Subject to modifications

## Spare Part List

Pos	12NC	Description
1001	<b>4812 440 10842</b>	Lid outer GW
1003	<b>4810 730 84355</b>	Lid inner
1040	<b>4810 107 58775</b>	Lid assembly, LR, WH, 15
1104	<b>4810 107 66214</b>	Handle LR, WH, 15
1300	<b>4801 111 04601</b>	Door lock Rold DA061667
1310	<b>4812 417 19193</b>	Door latch GW
1600	<b>4812 440 10838</b>	Front panel WH GW
1601	<b>4812 459 38057</b>	Flap round GW
1602	<b>4812 459 38058</b>	Hinge flap GW
1610	<b>4801 101 00103</b>	Rear panel
1620	<b>4812 440 10839</b>	Side panel right GW
1621	<b>4812 440 10841</b>	Side panel left GW
1810	<b>4812 529 18043</b>	Shock absorber
1811	<b>4801 101 00803</b>	Pin shock absorber
1820	<b>4810 105 05120</b>	Counter weight rear, LR
1821	<b>4810 105 55030</b>	Counter weight front
1822	<b>4812 466 88492</b>	Counter weight bottom
1823	<b>4812 310 18506</b>	Fixing mat.set bottom
1840	<b>4812 440 19625</b>	Drip tray assy
1850	<b>4812 462 48054</b>	Foot
1851	<b>4812 528 78075</b>	Foot rear
1870	<b>4812 440 11637</b>	Frame Top+nozzle box KIT
1871	<b>4810 750 23762</b>	Frame inner
1880	<b>4812 417 19155</b>	Hinge bolt lid GW
1910	<b>4812 466 68596</b>	Door bellow
1911	<b>4801 111 00817</b>	Strap f. Doorbellow
2000	<b>4812 418 18692</b>	Tub LR-5pins/4fix
2001	<b>4801 111 04401</b>	Cover f. tub LR/4fix
2002	<b>4801 111 02216</b>	Container LR 5 pins, kit
2200	<b>4810 108 22802</b>	Drum LR,0.5W,0.5E,1.8H,IB
2211	<b>4810 105 72443</b>	Kit latch f.drums
2230	<b>4801 101 00104</b>	Drum lifter low
2710	<b>4812 358 18204</b>	Belt PV 1207 J4 EL
2720	<b>4812 528 88083</b>	Pulley 298 mm
2900	<b>4812 532 68078</b>	Gasket
3010	<b>4810 108 32899</b>	Control panel
3012	<b>4810 107 65238</b>	Housing DLC, TL-R, 15
3310	<b>4810 107 74759</b>	Knob timer GRY, WP, 15
3312	<b>4812 414 58307</b>	Spring Knob timer
3314	<b>4810 108 44844</b>	Ring Button
3320	<b>4810 107 75207</b>	Button assy left, TL-R, GEY, 15
3321	<b>4810 108 51706</b>	Button assy Opt. 7-3,GRY,TL-R,15
3322	<b>4810 108 51700</b>	Button assy Opt. 7-4,GRY,TL-R,15
3323	<b>4810 108 44840</b>	Button Start grey
3430	<b>4810 714 25741</b>	Display
3500	<b>4810 714 28481</b>	Module
3510	<b>4810 107 64089</b>	Light guide Prog. Flow, TL-R, 15
3511	<b>4810 107 68256</b>	LIGHT GUIDE - LEFT, TL-R, 15
3512	<b>4810 107 68255</b>	Light guide Start, TL-R, 15
3513	<b>4810 107 64150</b>	Light guide SD Opt.5, TL-R, F1, 15

Pos	12NC	Description
3514	<b>4810 714 25711</b>	Light guide Display
4000	<b>4810 105 25484</b>	Motor HXGN1L.71
4210	<b>4810 105 94593</b>	Interf.filter
4212	<b>4812 404 38679</b>	Holder RFI
4300	<b>4810 730 71153</b>	Pump draining R2.5Y
4510	<b>4810 104 96465</b>	Heating element 2050W
4900	<b>4819 321 18136</b>	Cable mains 3X1620mm SA
4910	<b>4812 321 28367</b>	Strain relief
5210	<b>4810 108 08819</b>	Control unit WAVE, progr.
5211	<b>4810 107 89857</b>	CCU, WAVE_2 ECO, K5A2, -/- GRN, VAR.SUP.
5710	<b>4812 281 28468</b>	Valve magnet 1 inlet, 2 outlets
5810	<b>4812 271 28554</b>	Pressostat
6800	<b>4810 104 24468</b>	Soap dispenser cpl.
6910	<b>4812 282 19485</b>	Sensor NTC
7010	<b>4812 530 29256</b>	Hose inlet 1.5 m (Eltek)
7020	<b>4812 530 29453</b>	Hose valve-dispenser
7070	<b>4810 104 24466</b>	Nozzle box cpl.
7071	<b>4812 526 48049</b>	Clamp f. nozzle box
7430	<b>4812 418 68187</b>	Chamber,air
7540	<b>4812 530 28938</b>	Drainhose
7541	<b>4812 530 28832</b>	Lock eco
7552	<b>4812 530 29309</b>	Hose Air Exhaust
7553	<b>4812 530 29311</b>	Cover of hose
7630	<b>4812 480 58403</b>	Filter
7810	<b>4801 111 00272</b>	Hose draining
7830	<b>4812 530 28941</b>	Hose Pressostat
9000	<b>4812 401 18628</b>	Clamp hose 15,5 mm
9001	<b>4819 401 18872</b>	Clamp hose
9004	<b>4812 401 18431</b>	Clamp to pump
9005	<b>4819 401 18529</b>	Clamp hose
9009	<b>4812 255 18304</b>	Holder hose
9040	<b>4812 281 18069</b>	Cover for top frame
9041	<b>4812 462 79974</b>	Cap Transport blocking
9100	<b>4812 502 48347</b>	Screw,selftap 3,5x14
9101	<b>4812 502 38151</b>	Screw 4x14
9102	<b>4801 101 00801</b>	Screw M8x18
9103	<b>4801 111 04699</b>	Screw M8x22,5/DD
9105	<b>4812 502 18423</b>	Screw PT 7x15
9106	<b>4801 111 02619</b>	Nut M8
9107	<b>4812 310 19224</b>	Fixing mat.set Counter weight
9110	<b>4812 502 18828</b>	Screw Motor, kit
9301	<b>4812 492 48171</b>	Torsions spring
9302	<b>4812 492 48162</b>	Spring
9303	<b>4812 290 18025</b>	Clamp heating element
9410	<b>4812 310 19144</b>	Bearing kit ALL 1100
9500	<b>4810 107 77092</b>	Shaft seal V-22A
9503	<b>4810 103 95017</b>	Gasket airtrap
9930	<b>4819 530 29028</b>	U Curve for outlet hose

## Exploded View

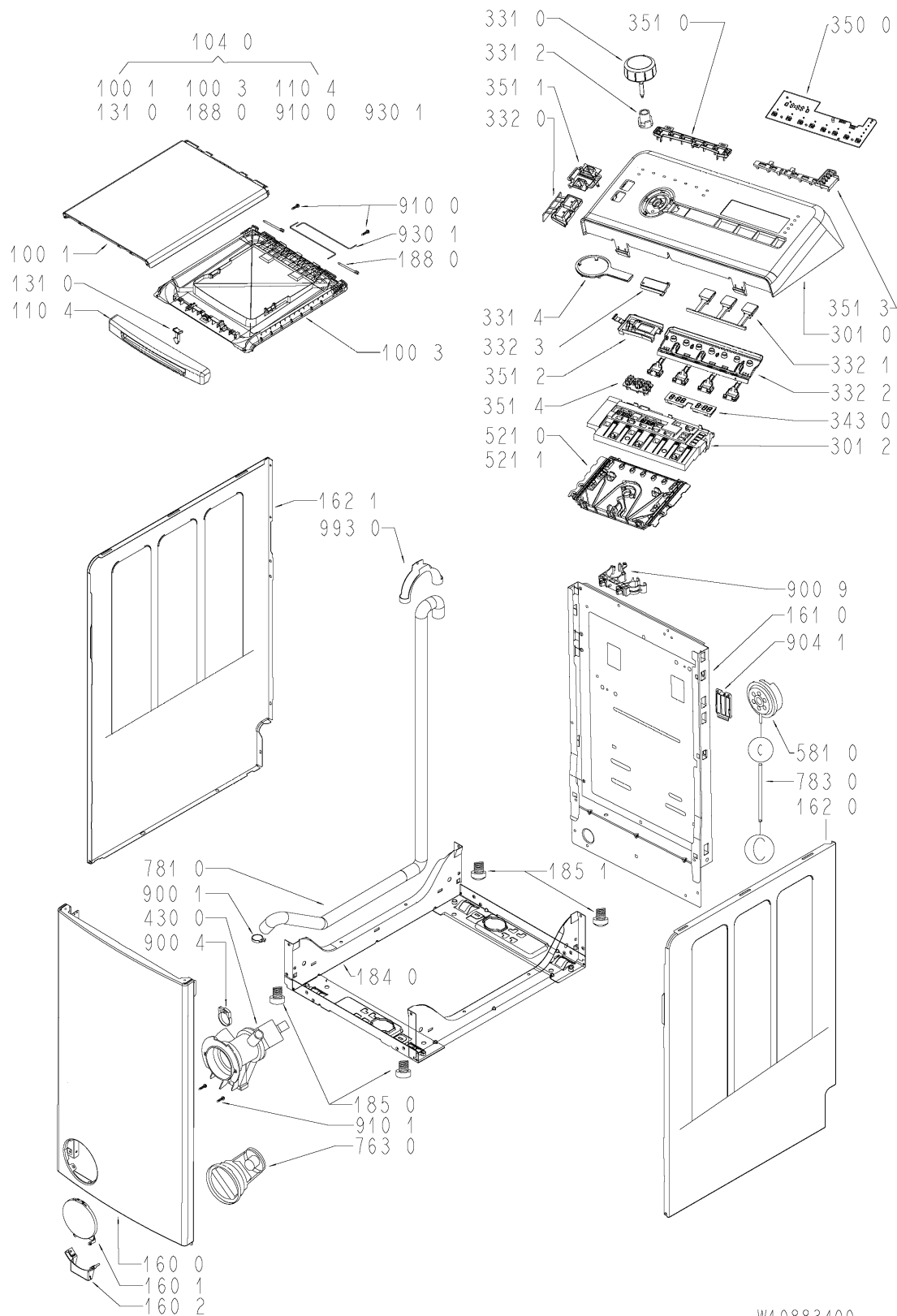

W10883400

## Exploded View

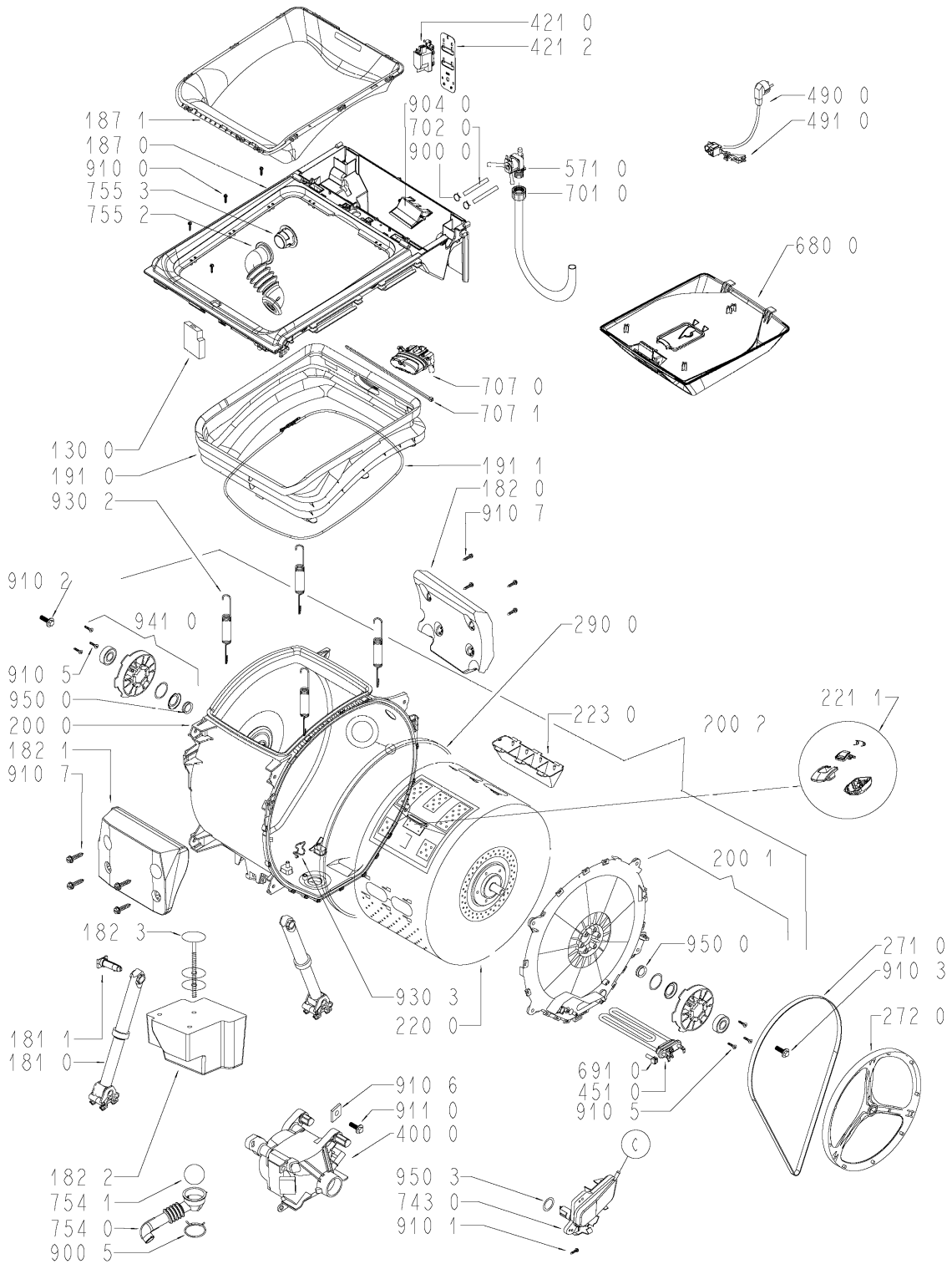

W10883400

## Technical Data

### Dimensions + Weight

Product dimensions	
Height .....	90 cm
Width .....	40 cm
Depth .....	60 cm
Weight	
net .....	63 kg

### Electrical base data

Voltage .....	230 V $\pm$ 10 %
Frequency .....	50 Hz
Fuse .....	10 A
Power Consumption .....	~2.3 kW

### Drum data

Volume .....	42 l
Wash speed .....	52 rpm
Spinning	
max. ....	1000 rpm

### Door lock

Kind of switch .....	Switch with PTC heater of bimetal
Nominal voltage .....	230 V +10 %, -15 %
Locking time .....	< 6 s
Unlock time .....	40 - 220 s

### Pressostat

Level1 .....	11 - 12/14
Overflow .....	11 - 16

### Inlet valve

Nominal voltage .....	220 - 240 V / 50 Hz
Rated flow .....	(1.5 - 5 bar) 8 l/min
Pressure range .....	0.3 - 10 bar
Nominal resistance .....	(20 °C) 3.8 k $\Omega$

### Drain pump

Nominal voltage .....	220 - 240 V / 50 Hz
Total power .....	26 W
Resistor (coil) .....	224 $\Omega$
Capacity .....	14 $\pm$ 2 l/min
Position of draining hose outlet .....	0.9 - 1.25 m

## Heating element

Nominal voltage .....	230 V +10%, -15%
Total power .....	2050 W ± 5%
Resistance (20 °C) .....	23.9/25.8 Ω ± 5%
Leakage current .....	< 0.8 mA
NTC sensor	
Resistance NTC	

0 °C	35.9	kΩ
30 °C	9.8	kΩ
40 °C	6.6	kΩ
50 °C	4.6	kΩ
60 °C	3.2	kΩ
70 °C	2.3	kΩ
95 °C	1.1	kΩ

## Motor

Resistance contacts .....	(20 °C)
Stator (full field) .....	2.00 Ω
Rotor .....	2.09 Ω
Tacho generator .....	66.60 Ω

## Control unit

Type .....	WAVE
Nominal voltage .....	230 V - 240 V
Frequency .....	50 Hz
Output control unit	

Motor	M7.6 - DSS3.2	>40 V
Aquastop	AQ2.2 - DSS3.2	230 V
In pump step	AQ2.1 - DSS3.3	230 V
NTC	Not measurable	—
Pump	DP2.1 - DP2.2	230 V
Doorlock	DSS3.1 - DSS3.3	230 V
Pressostat	E4 - E2	230 V
- empty	PR2.1 - E2	230 V
- full	PR2.2 - E2	230 V
Valve (Rast 2.5)	V2.1 - V2.2	>170 V
Options	Not measurable	—

## Wiring Diagram

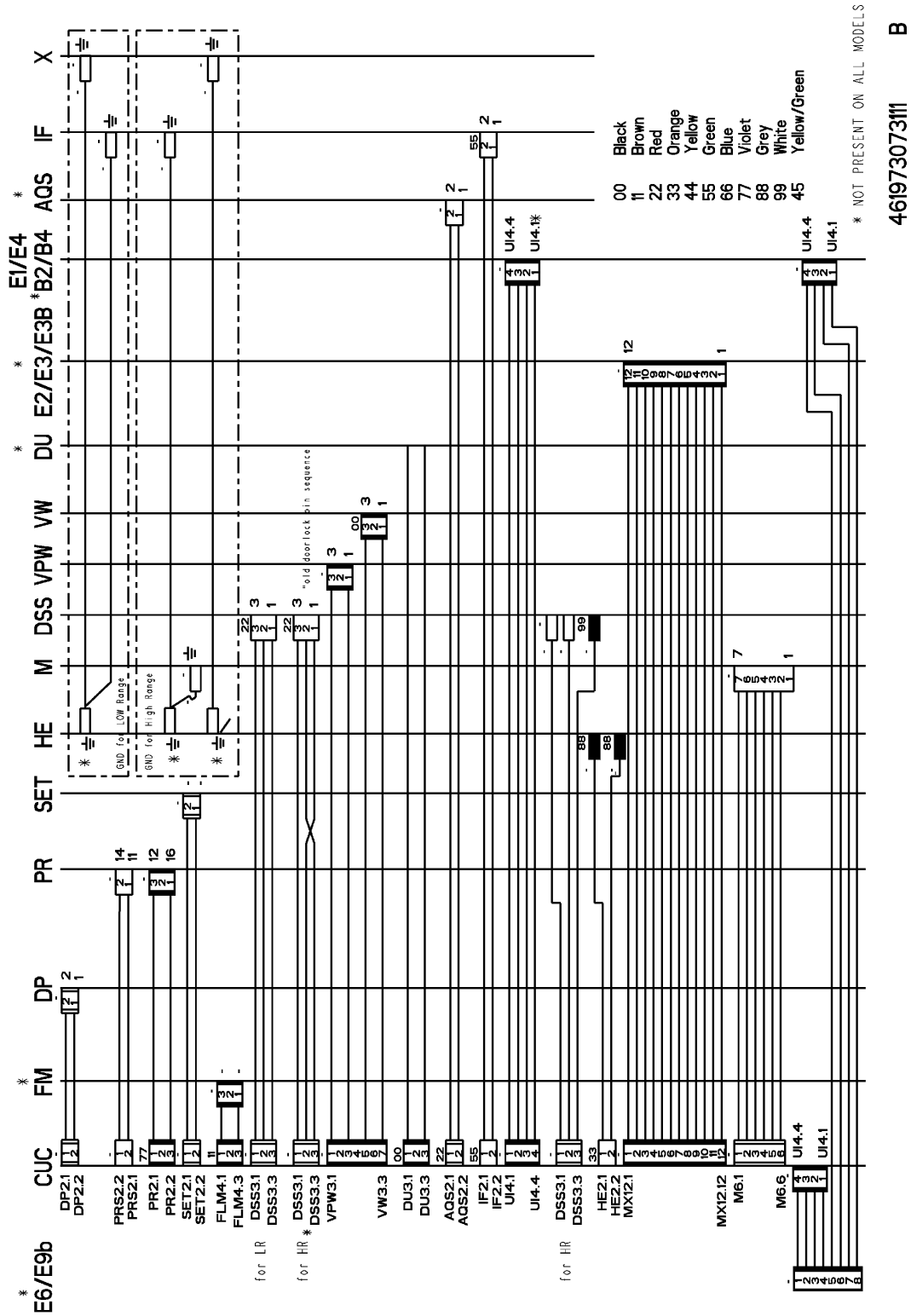



## Legend

00	black
11	brown
22	red
33	orange
44	yellow
55	green
66	blue
77	violet
88	grey
99	white
45	yellow/green

## Circuit Diagram

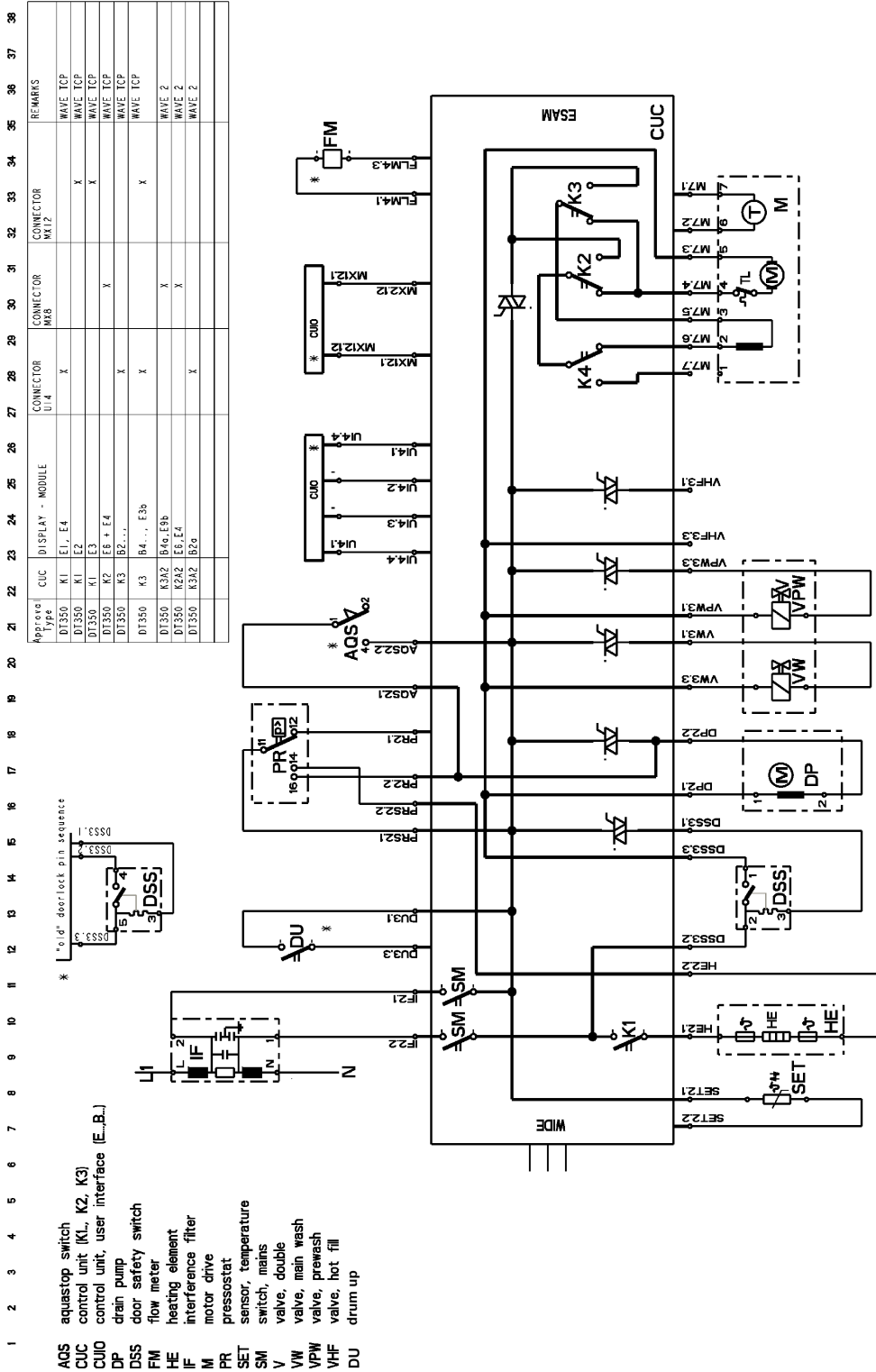

\* NOT PRESENT ON ALL MODELS  
461973073111 B

## Legend

AQS	aquastop switch
CUC	control unit (K1, K2, K3)
CUIO	control unit, user interface (E..., B...)
DP	drain pump
DSS	door safety switch
DU	drum up
FM	flow meter
HE	heating element
IF	interference filter
M	motor drive
PR	pressostat
SET	sensor, temperature
SM	switch, mains
V	valve, double
VW	valve, main wash
VPW	valve, prewash
VHF	valve, hot fill

## Program Chart

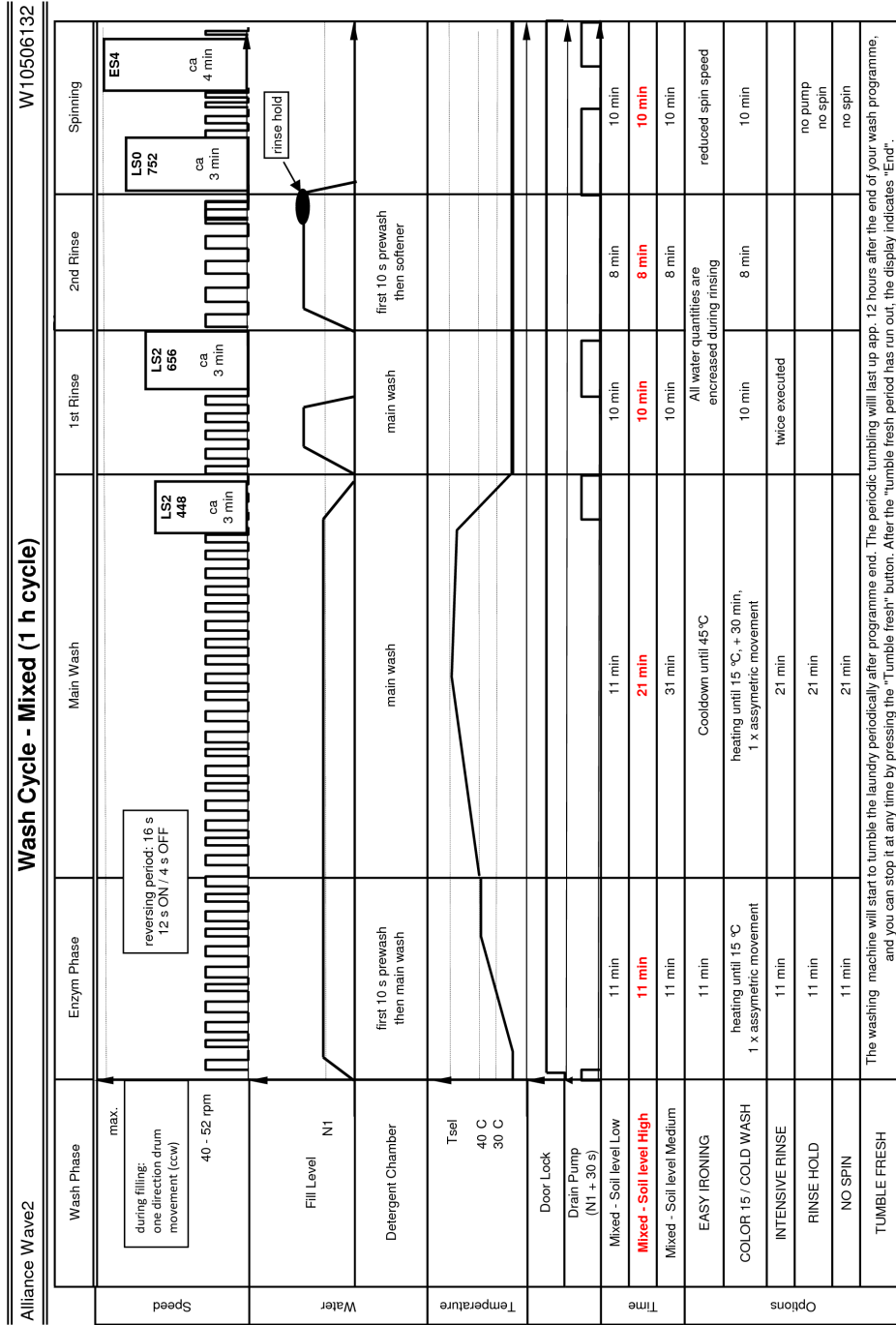

Alliance Wave2		Wash Cycle - Cotton 95°C					W10506132	
	Wash Phase	Prewash	Enzym Phase	Main Wash	1st Rinse	2nd Rinse	Spinning	
Speed	max. during filling: one direction drum movement (ccw)  40 - 52 rpm		reversing period: 16 s 10...14 s ON / 6...2 s OFF					
Water	Fill Level N1							
Temperature	Detergent Chamber  Tsel 30 C	prewash	first 10 s prewash then main wash	main wash	main wash	first 10 s prewash then softener		
Time	Door Lock Drain Pump (N1 + 30 s)  Large load / High Soil level Mid load Small load Quick Prewash Extra Rinse	18 min 18 min 18 min 18 min 19 min	18 min ~ 58 min ~ 58 min ~ 50 min 18 min	~ 60 min ~ 58 min ~ 58 min ~ 60 min ~ 60 min	14 min 14 min 14 min 14 min twice executed 14 min	8 min 8 min 8 min 8 min 8 min	14 min 14 min 14 min 14 min 14 min	
Options	TUMBLE FRESH Clean + Easy Ironing		5 minutes longer 18 min	Cooldown until 45°C	All water quantities are increased during rinsing (+3L)			ES3 752 ~ 2min LS 656 4 min
		The washing machine will start to tumble the laundry periodically after programme end. The periodic tumbling will last up app. 12 hours after the end of your wash programme, and you can stop it at any time by pressing the "Tumble fresh" button. After the "tumble fresh" period has run out, the display indicates "End".						

		Wash Cycle - Cotton 60°C					W10506132	
	Wash Phase	Prewash	Enzym Phase	Main Wash	1st. Rinse	2nd Rinse	Spinning	
Speed	max. during filling: one direction drum movement (ccw) 40 - 52 rpm		reversing period: 16 s 8...14 s ON / 8...2 s OFF	LSO 656 (448) ca 4 min	LSO 656 ca 4 min	LSO 656 4 min rinse hold	ES2 Mex 6 min LSO 656 4 min	
Water	Fill Level N1			main wash	main wash	main wash		
Temperature	Detergent Chamber Tsel 40°C 30°C	prewash		main wash	main wash			
	Door Lock							
	Drain Pump (N1 + 30 s)							
Time	Large load / High Soil level		18 min	~ 86 - 96 min	14 min	8 min	14 min	
	Mid load		18 min	~ 61 - 71 min	14 min	8 min	14 min	
	Small load		18 min	~ 24 min	14 min	8 min	14 min	
	Medium soil level		18 min	~ 17 min (small load) ~ 56 min (mid load) ~ 76 min (large load)	14 min	8 min	14 min	
	Low soil level		18 min	~ 12 min (small load) ~ 41 min (mid load) ~ 56 min (large load)	14 min	8 min	14 min	
	CLEAN PLUS		5 minutes longer	~ 86 - 96 min	14 min	8 min	14 min	
	TUMBLE FRESH	The washing machine will start to tumble the laundry periodically after programme end. The periodic tumbling will last up app. 12 hours after the end of your wash programme, and you can stop it at any time by pressing the "Tumble fresh" button. After the "tumble fresh" period has run out, the display indicates "End".						
Options	COLOR 15 / COLD WASH		heating until 15 °C		14 min	8 min	14 min	
	RAPID		18 min	~ 51 min	14 min	8 min	14 min	
	PREWASH	19 min	18 min	~ 86 - 96 min	14 min	8 min	14 min	
	NO SPIN		18 min	~ 86 - 96 min	14 min	8 min	no spin	
	INTENSIVE RINSE		18 min	~ 86 - 96 min	twice executed	8 min	14 min	no pump no spin
	RINSE HOLD		18 min	~ 86 - 96 min	14 min	8 min	no pump no spin	
	EASY IRONING		18 min	Cooldown until 45°C	All water quantities are increased during rinsing (+3L)		ES3 752 ~ 2min LS 656 4 min	

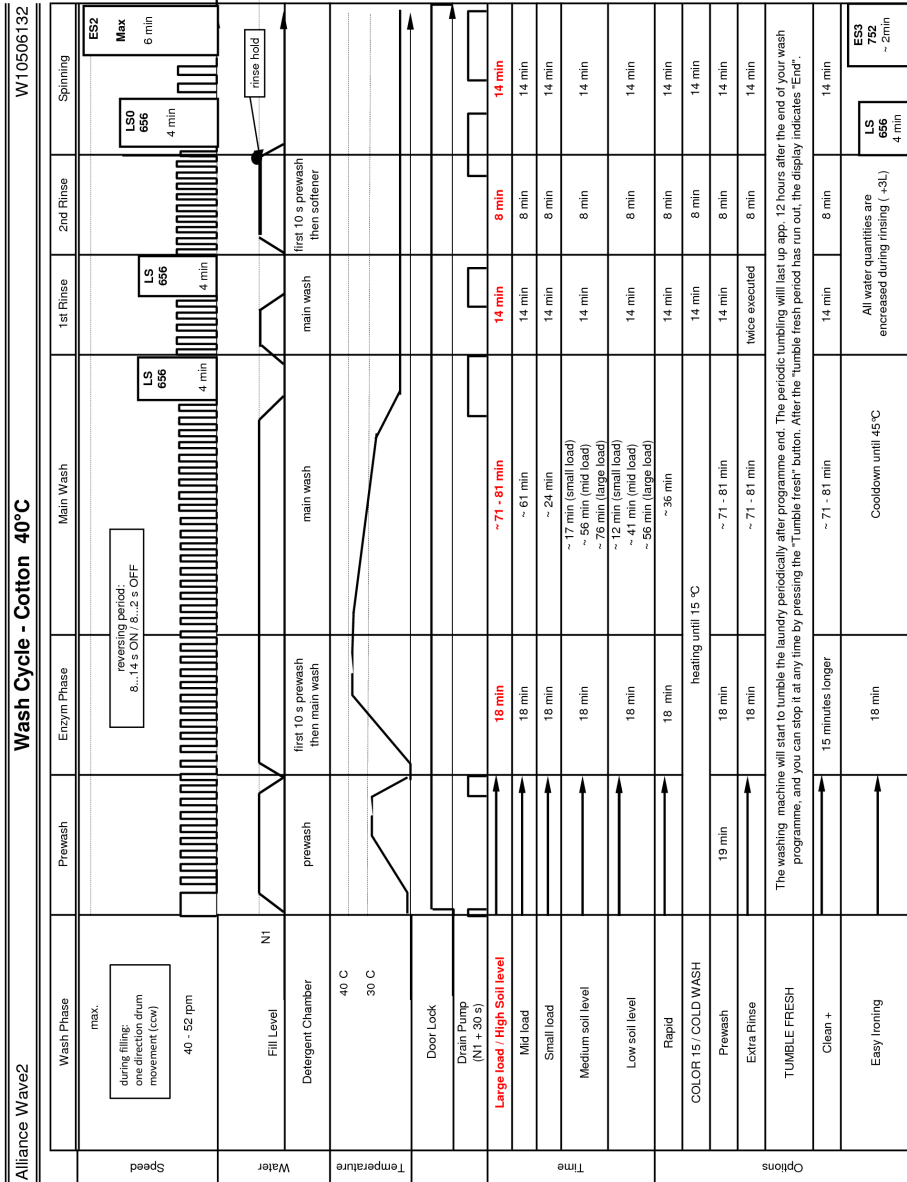

		Wash Cycle - Synthetic, Sport						W10506132	
Wash Phase	Prewash	Enzym Phase	Main Wash	1st Rinse	2nd Rinse	3rd Rinse	Spinning		
Speed	max. 40 - 52 rpm		reversing period: 16 s 10 s ON / 6 s OFF and 12 s ON / 4 s OFF	LS3 848 ca. 3 min	LS3 848 ca. 3 min	LS3 848 ca. 3 min	LS0 752 ca. 3 min	ES2 ca. 4 min	
Water	Fill Level N1	first 10 s prewash then main wash	main wash	main wash	main wash	10 s prewash then softener			
Temperature	Detergent Chamber Tsel 40 C 30 C	prewash							
	Door Lock								
	Drain Pump (N1 + 30 s)								
Time	Easy Care 40/60 Low Soil	15 min	35 ... 50 min	10 min	10 min	7 min	8 min		
	<b>Easy Care 40/60 Mid Soil</b>	<b>15 min</b>	<b>55 ... 70 min</b>	<b>10 min</b>	<b>10 min</b>	<b>7 min</b>	<b>8 min</b>		
	Easy Care 40/60 High Soil	15 min	75 ... 90 min	10 min	10 min	7 min	8 min		
	The washing machine will start to tumble periodically after programme end. The periodic tumbling will last up app. 12 hours after the end of your wash programme, and you can stop it at any time by pressing the "Tumble fresh" button. After the "tumble fresh" period has run out, the display indicates "End".								
Options	TUMBLE FRESH	+ 15 min	55 ... 70 min	10 min	10 min	7 min	8 min		
	CLEAN PLUS		heating until 15 °C	10 min	10 min	7 min	8 min		
	COLOR 15 / COLD WASH		heating until 15 °C	10 min	10 min	7 min	8 min		
	RAPID		<b>5 ... 20 min</b>	10 min	10 min	7 min	8 min		
	PREWASH	19 min	55 ... 70 min	10 min	10 min	7 min	8 min		
	NO SPIN		55 ... 70 min	10 min	10 min	7 min	No spin		
	INTENSIVE RINSE		55 ... 70 min	twice executed	10 min	7 min	8 min		
	RINSE HOLD		55 ... 70 min	10 min	10 min	7 min	no pump no spin		
	EASY IRONING		15 min	15 min	10 min	7 min	reduced spin speed, All water quantities are increased during rinsing ( +2L)		reduced spin speed

(1) Sport/Leisure/Outdoor: Synthetic 30°C with integrated prewash option



Alliance Wave2		Wash Cycle - Delicate							W10506132		
	Wash Phase	Prewash	Enzym Phase	Main Wash	1st Rinse	2nd Rinse	3rd Rinse	Spinning			
Speed	960 rpm  40 - 52 rpm		reversing period: 16 s 4 s ON / 12 s OFF					LS0 960 ca 3 min  ES3 960 ca 3 min			
Water	Fill Level N1					rinse hold					
Temperature	Detergent Chamber  40 C 30 C	prewash	first 6 l prewash (without movement) then main wash	main wash	main wash	main wash	first 10 s prewash then softener				
	Door Lock										
	Drain Pump (N1 + 30 s)										
Time	Delicate / Low soil		3 min	22 min	3 min	3 min	3 min	8 min			
	Delicate / Mid soil		3 min	37 min	3 min	3 min	4 min	8 min			
	TUMBLE FRESH	The washing machine will start to tumble periodically after programme end. The periodic tumbling will last up app. 12 hours after the end of your wash programme, and you can stop it at any time by pressing the "Tumble fresh" button. After the "tumble fresh" period has run out, the display indicates "End".									
Options	COLOR 15 / COLD WASH		heating until 15 °C		3 min	3 min	3 min	8 min			
	PREWASH	19 min	3 min	22 min	3 min	3 min	4 min	8 min			
	RINSE HOLD		3 min	22 min	3 min	3 min	4 min	no pump no spin			
	NO SPIN		3 min	22 min	3 min	3 min	4 min	no spin			

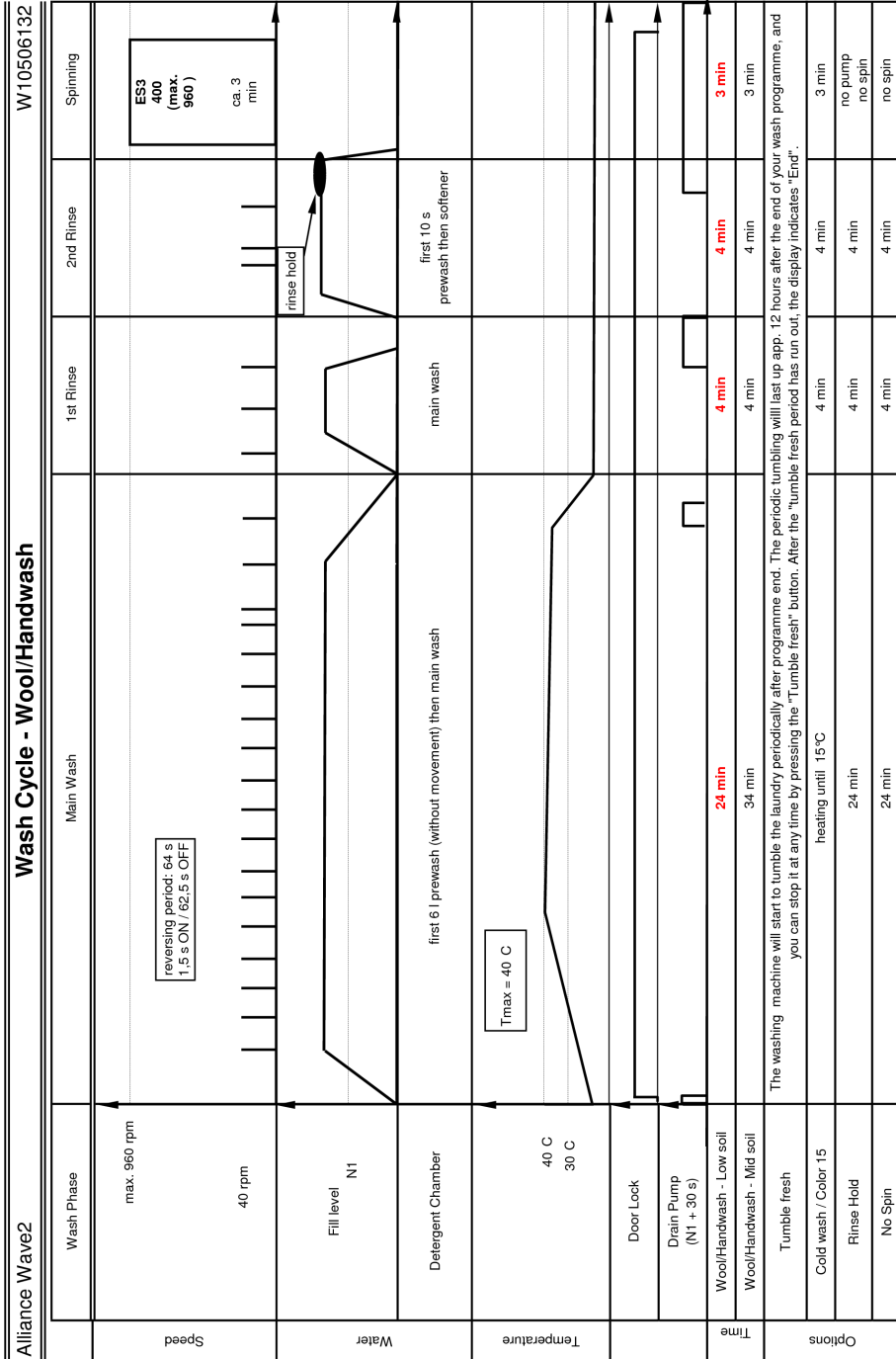

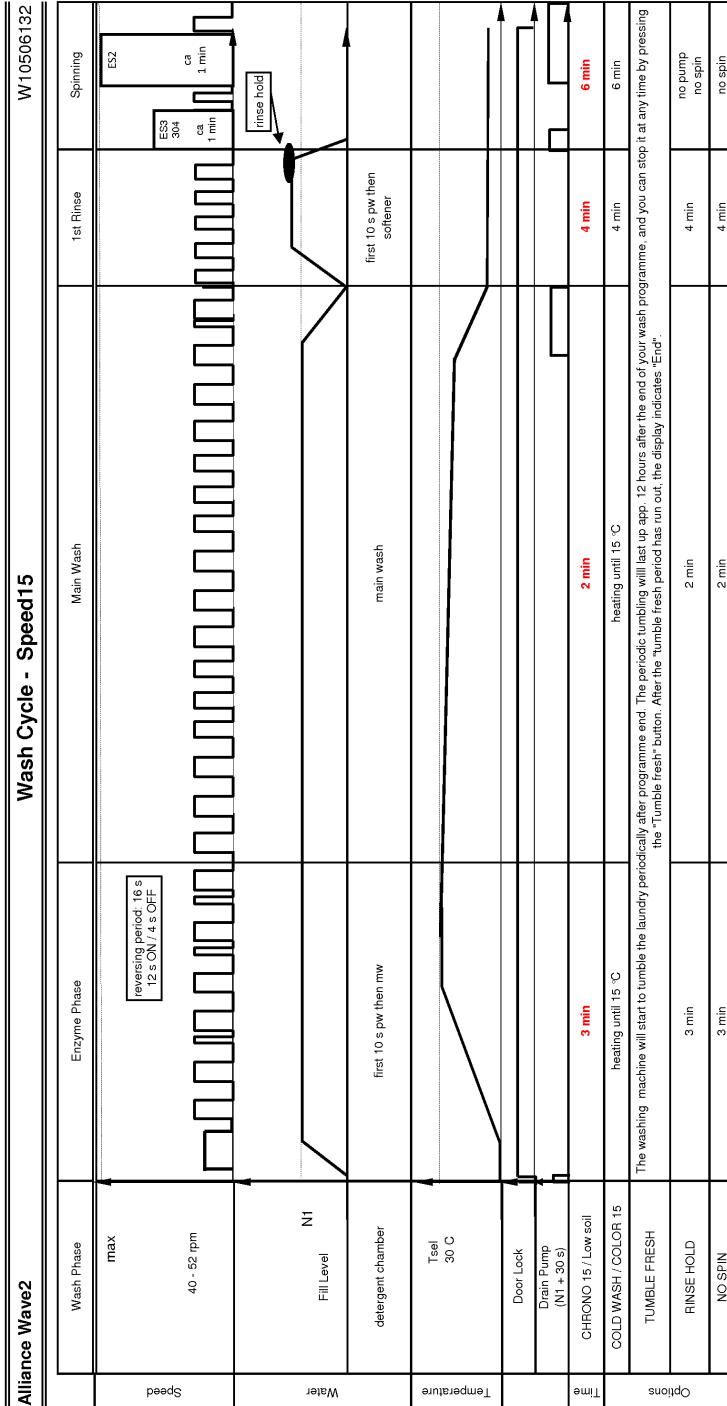

Alliance Wave2		Wash Cycle - AquaEco			W10506132	
	Wash Phase	Enzym Phase	Main Wash	1st. rinse	spinning	
Speed	max 40-52 rpm	reversing period: 16 s 12 s ON / 4 s OFF	LS3 848 ca 3 min	LS2 752 ca 2 min	ES3 ca 5 min	
Water	Fill Level N1	first 10 s pw then mw	main wash	first 10 s pw then softener		
Temperature	detergent chamber  Tsel 40 C					
	Door Lock					
	Drain Pump (N1 + 30 s)					
Time	AquaEco - Low soil COLD WASH / COLOR 15	12 min heating until 15 °C	26 min heating until 15 °C	13 min 13 min	9 min 9 min	
Options	TUMBLE FRESH	The washing machine will start to tumble periodically after programme end. The periodic tumbling will last up app. 12 hours after the end of your wash programme, and you can stop it at any time by pressing the "Tumble fresh" button. After the "tumble fresh" period has run out, the display indicates "End".				
	RINSE HOLD				no pump no spin	
	NO SPIN				no spin	

Alliance Wave2		Wash Cycle - EcoCotton 40°C,60°C (Reference programmes)					W10506132
	Wash Phase	Enzym Phase	Main Wash	1st Rinse	2nd Rinse	Spinning	
Speed	max. during filling: one direction drum movement (ccw)  40 - 52 rpm		reversing period: 16 s 8...14 s ON / 8...2 s OFF	LSO 656 (448) 4.5 min	LSO 656 4.5 min	LSO 656 4 min  ES2 Max 24 min	
Water	Fill Level N1			rinse hold	main wash	short spin for Small Loads detected ~ 9 min	
Temperature	Detergent Chamber Tsel 40(30) C 30 C		main wash	main wash	main wash		
Time	Door Lock Drain Pump (N1 + 30 s) EcoCotton 40 / 60 Large load / High Soil EcoCotton 40 / 60 Load detected: medium EcoCotton 40 / 60 Load detected: small  EcoCotton 60 / Mid soil  EcoCotton 60 / Low soil	23 min  23 min  23 min	50 ... 130 min  69 ... 84 min  10 ... 20 min  20 min (small load) 56 min (mid load) 112 min (large load)  7 min (small load) 31 min (mid load) 48 min (large load)  50 ... 130 min	13 min  13 min  13 min  13 min  13 min  twice executed	13 min  13 min  13 min  13 min  13 min	32 min  32 min  9 min  32 min  32 min  32 min	
Options	INTENSIVE RINSE COLD WASH / COLOR 15 TUMBLE FRESH RINSE HOLD NO SPIN	heating until 15 °C  The washing machine will start to tumble the laundry periodically after programme end. The periodic tumbling will last up app. 12 hours after the end of your wash programme, and you can stop it at any time by pressing the "Tumble fresh" button. After the "tumble fresh" period has run out, the display indicates "End".				no pump no spin no spin	

Alliance Wave2		Wash Cycle - Black&Dark						W10506132
	Wash Phase	Prewash	Enzyme Phase	Main Wash	1st Rinse	2nd Rinse	3rd Rinse	Spinning
Speed	max. 40-52 rpm	reversing period = 16 s 6 s ON / 10 s OFF	2x3min asymmetric movement 7-4-4-7	peak	peak	peak	peak	pre-extraction peaks + final spin at 1200 rpm max ca. 3 min
Water	Fill Level N1	prewash	first 10 s prewash then mainwash	main wash	main wash	main wash	first 10 s prewash then softener	
Temperature	Tmax = 60 C 40 C							
	DoorLock							
	Drain Pump (NT + 30 s)							
	<b>Dark Colors - Large load / Medium soil</b>	16 min	16 min	~54 min	9 min	9 min	8 min	9 min
	Dark Colors - Small load	16 min	16 min	~19 min	9 min	9 min	8 min	9 min
	Dark Colors (40°C) / High soil level	16 min	16 min	27 min (small load) 69 min (large load)	9 min	9 min	8 min	9 min
	Dark Colors (40°C) / Low soil level	16 min	16 min	11 min (small load) 29 min (large load)	9 min	9 min	8 min	9 min
	PREWASH	19 min	16 min	~19 min	9 min	9 min	8 min	9 min
	RAPID		16 min	heating until 15°C	9 min	9 min	8 min	9 min
	COLD WASH / COLOR 15		16 min	heating until 15°C	9 min	9 min	8 min	9 min
	EXTRA RINSE		16 min	twice executed	9 min	9 min	8 min	9 min
	TUMBLE FRESH	The washing machine will start to tumble periodically after programme end. The periodic tumbling will last up app. 12 hours after the end of your wash programme, and you can stop it at any time by pressing the "Tumble fresh" button. After the "tumble fresh" period has run out, the display indicates "End".						
	RINSE HOLD	16 min	16 min	~54 min	9 min	9 min	8 min	No pump No spin
	NO SPIN	16 min	16 min	~54 min	9 min	9 min	8 min	No spin

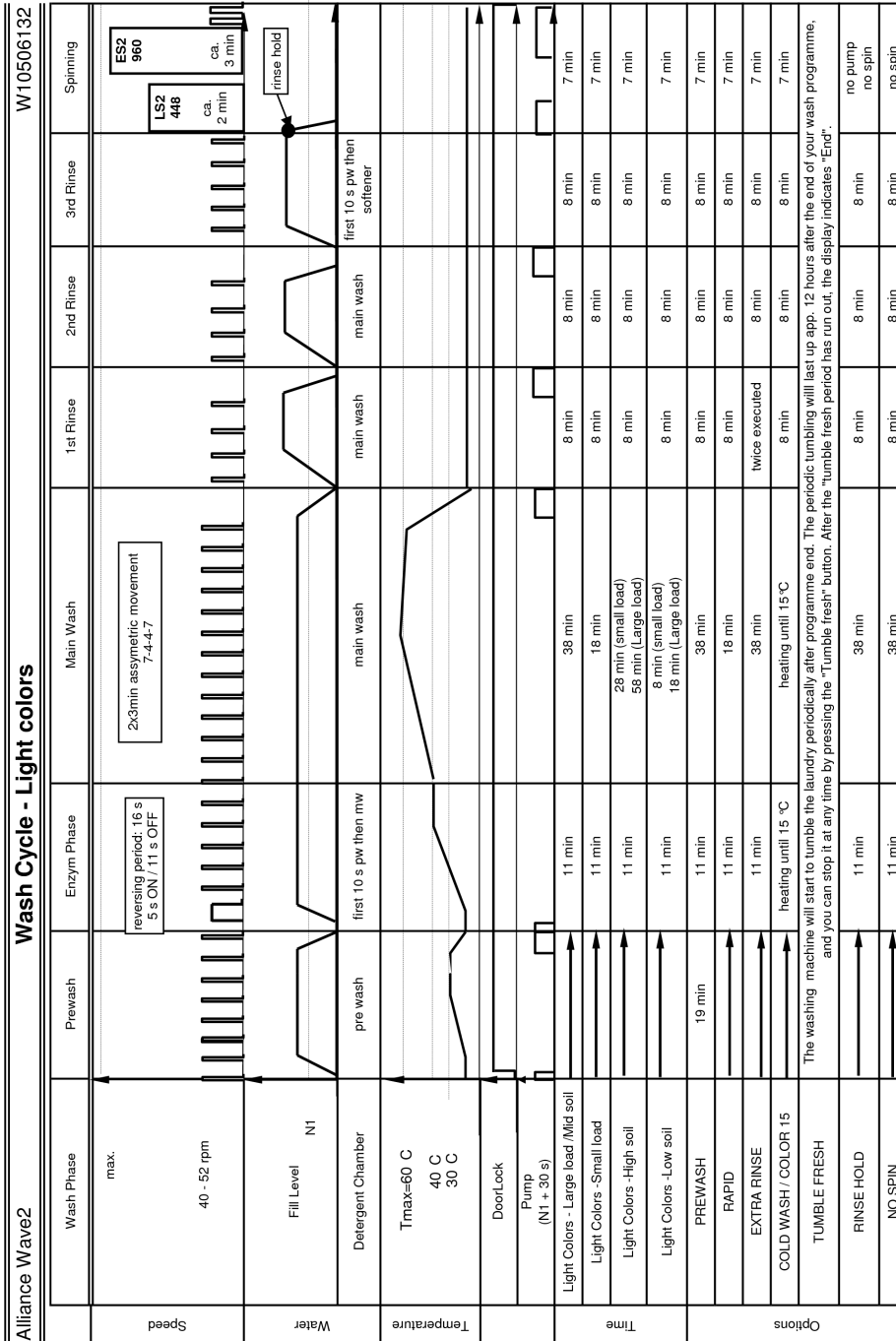

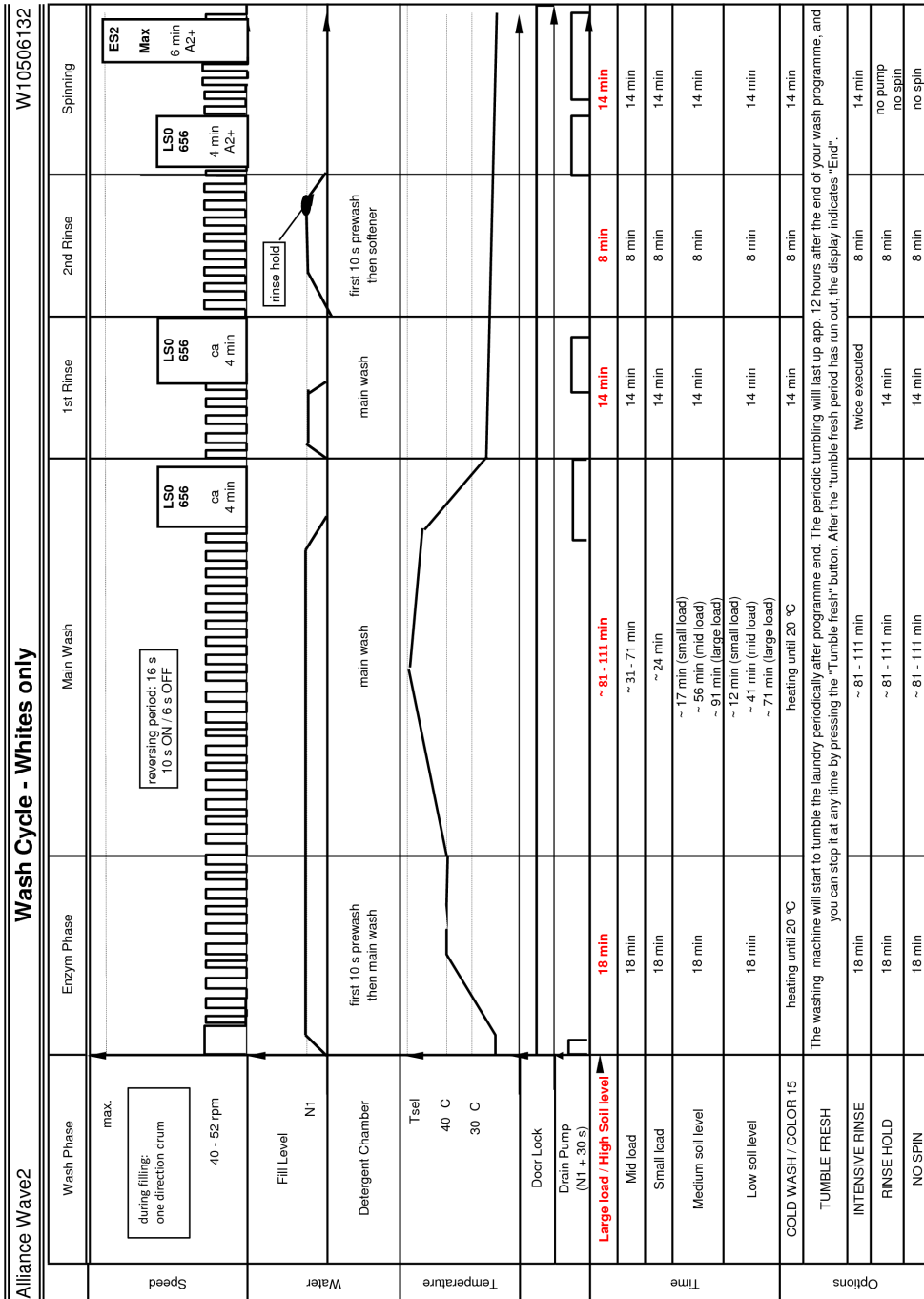



Alliance Wave2		Wash Cycle - Jeans						W10506132
Speed	Wash Phase	Prewash	Enzyme Phase	Main Wash	1st Rinse	2nd Rinse	3rd Rinse	Spinning
	max. 40-52 rpm	reversing period = 16 s 6 s ON / 10 s OFF	2x3min asymmetric movement 7-4-4-7	peak	peak	peak	peak	pre-extraction peaks + final spin at 1200 rpm max ca. 3 min
Water	Fill Level N1							
	Detergent Chamber	prewash	first 10 s prewash then mainwash	main wash	main wash	main wash	first 10 s prewash then softener	
Temperature	Tmax = 60 C 40 C							
	DoorLock							
	Drain Pump (N1 + 30 s)							
	Large load / Medium soil	16 min	16 min	~39 min	9 min	9 min	8 min	9 min
	Small load	16 min	16 min	~19 min	9 min	9 min	8 min	9 min
	High soil level	16 min	16 min	27 min (small load) 59 min (large load)	9 min	9 min	8 min	9 min
	Low soil level	16 min	16 min	11 min (small load) 19 min (large load)	9 min	9 min	8 min	9 min
	PREWASH	19 min	16 min	~39 min	9 min	9 min	8 min	9 min
	RAPID	16 min	16 min	~19 min	9 min	9 min	8 min	9 min
	COLD WASH / COLOR 15	heating until 15°C	heating until 15°C	heating until 15°C	9 min	9 min	8 min	9 min
	EXTRA RINSE	16 min	16 min	~39 min	twice executed	9 min	8 min	9 min
	TUMBLE FRESH	The washing machine will start to tumble the laundry periodically after programme end. The periodic tumbling will last up app. 12 hours after the end of your wash programme, and you can stop it at any time by pressing the "Tumble Fresh" button. After the "Tumble Fresh" period has run out, the display indicates "End".						
	RINSE HOLD	16 min	16 min	~39 min	9 min	9 min	8 min	No pump No spin
	NO SPIN	16 min	16 min	~39 min	9 min	9 min	8 min	No spin

W10506132

## Wash Cycle - Spin profiles

Alliance Wave2



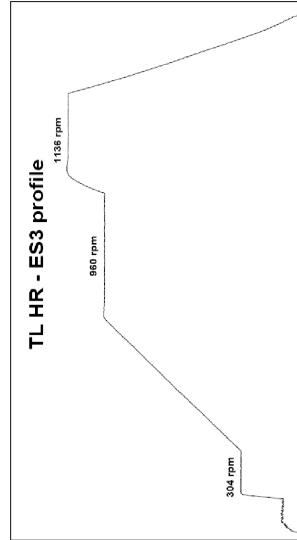
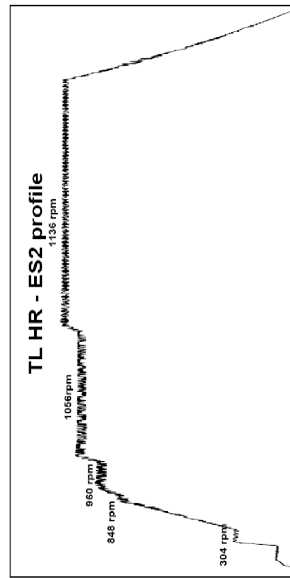
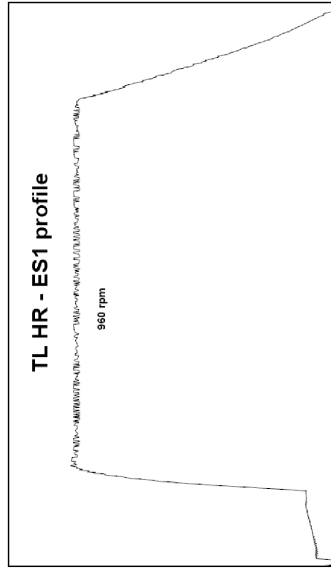
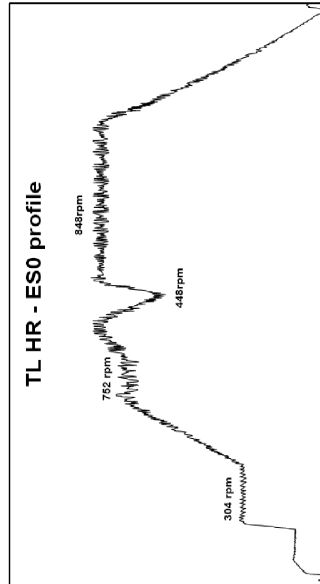







- LS0 = Peak 0 + ES0
- LS1 = Peak 1 + Peak 2 + Peak 3 + Peak 4
- LS2 = Peak 0 + Peak 3
- LS3 = Peak 0 + ES0
- Peak 1 = 304 rpm
- Peak 2 = 608 rpm
- Peak 3 = 656 rpm
- Peak 4 = 848 rpm

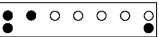

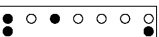
## Testprogram

	<b>For appliances with program selection with a rotary knob.</b>
1.	Close the door.
2.	Select the first mechanically available position of the rotary program selector on the left of the OFF position (usually "DRAIN" or "SPIN").
3.	Press push button Reset 4 times within 5 seconds.
4.	The last Fault code is shown in the display, press the Start button to advance.
5.	The 2nd to last Fault code is shown in the display, press the Start button to advance.
6.	The 3rd to last Fault code is shown in the display, press the Start button to start the Test Program.
7.	To go to next step, press the Reset button twice.
8.	To go to step C5, press the Start button once.

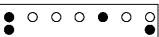



### Attention: Use the test program only without laundry!







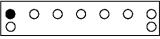



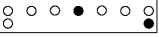

ICON - Phases	Digits Temperature	Description of the Program Flow	Check to perform
 Icons are switched on and off in a sequence from left to right and back.	C0	The door is locked. The CCU is performing the Selftest.	CCU detects: • F02, F05, F08, F12, F13, F14, F15, F21, F23, F26
 	C1	Fill x seconds hot valve (only if hot fill appliance) Fill x seconds in prewash (PW) Fill x seconds in mainwash (MW) Fill x seconds in PW + MW (Softener) Fill by MW to wash level. Motor is reversing.	Technician: • Check the valve activation • Check the dispensing into the dispenser • Check the pressure switch • <b>Note:</b> X seconds for filling depend by the model. For washers produced before than 07/2011 is 15 seconds. After 07/2011 is 5 seconds
 	C2	The heating element is switched ON. Motor is reversing.	Technician: • Check heating element activation • Check if the motor is reversing  CCU detects: • F06, F07, F27
 	C3	The drain pump is switched ON until the wash level = OFF + 5" motor is reversing.	Technician: • Check drain pump activation • Check pressure switch operation • Check if the motor is reversing  CCU detects: • F06, F07, F27, F03
 	C4	The motor is driven to maximum speed. Drain pump is ON.	Technician: • Check if the motor is running at max. speed • Check drain pump activation  CCU detects: • F28
 	C5	Motor is switched OFF. Door is unlocked. Washer Machine is OFF	Technician: • Check if the door is unlocked  CCU detects: • F13

Digits of "Rest time" are executing an animation, Digits of "Speed" are OFF



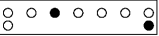

WAVE ECO W10502177

## Error Codes



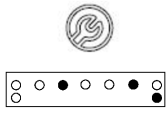

Failure Indication		Explanation and Recommended Procedure
Icon Active	On Digits 3 - 5	
Appliance "dead"	no indication at all or read out by ESAM F60 - F63	<p><b>CCU failure</b></p> <p><b>Potential Causes</b></p> <p>Read out failure code with ESAM:</p> <ul style="list-style-type: none"> <li>• If F60 - F63 is displayed:</li> <li>• Check if NTC has a short circuit.</li> <li>• Check if NTC wiring has a short circuit</li> <li>• If NTC and wiring is ok, change the CCU</li> </ul>
		<p><b>Door Lock failure</b></p> <p>If the CCU is not able to lock the door of the washer after program start within 20", CCU is going to selection mode (LED of start/pause button is flashing)</p> <p><b>Potential Causes</b></p> <ul style="list-style-type: none"> <li>• mechanical issue with door/ door hook/ door lock interface</li> <li>• door not completely closed</li> <li>• door lock issue</li> </ul>
<p>During normal cycle execution</p>  <p>During test program</p>  	<p>During normal cycle execution</p> <p>Remaining Time</p> <p>During test program</p> <p>F01</p>	<p><b>No water detected entering machine or pressure switch trip not detected.</b></p> <p>If after 6 minutes the control does not detect water entering machine, then valves will be turned off and the LED Water Tap will be switched ON.</p> <p>The Control is in Pause Mode. If it was possible to remove the failure, by pushing PB Start the appliance will restart.</p> <p><b>Potential Causes</b></p> <ul style="list-style-type: none"> <li>• <b>If there is no water in the unit:</b></li> <li>• Make sure that both valves at the water source(s) are turned on all the way.</li> <li>• Check for plugged or kinked inlet hoses or plugged filter in the inlet valves.</li> <li>• Verify inlet valve operation.</li> <li>• <b>If there is water in the unit:</b></li> <li>• Pressure switch hose is in good condition and properly connected to tub and pressure switch.</li> <li>• Verify there is not a siphon problem.</li> <li>• Verify wire harness connections to; inlet valves, pressure switch and central control unit (CCU).</li> <li>• Check all hoses for possible leaks.</li> <li>• Verify pressure switch operation.</li> <li>• Verify CCU operation.</li> </ul>
	F02	<p><b>Aquastop Failure</b></p> <p>If the aquastop contact on the bottom tray of the appliance is closed for more than 30" an aquastop failure will be detected. In aquastop condition the drain pump will run for 3 to 6 minutes. Afterwards the drain pump is off and the door will unlock.</p> <p><b>Potential Causes</b></p> <ul style="list-style-type: none"> <li>• <b>If there is water in the bottom tray of the appliance:</b></li> <li>• Check all hoses for any leakage.</li> <li>• Check if there was overfoam due to too much detergent used.</li> <li>• Check the tub for any leakage.</li> <li>• <b>If there is no water in the bottom tray:</b></li> <li>• Check if the aquastop switch has a short circuit.</li> <li>• Check if the aquastop wiring is properly connected.</li> <li>• Verify CCU operation. (Check also for F26: Pump triac short circuit is causing this code.)</li> </ul>

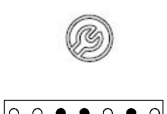
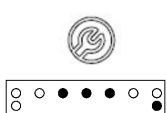
<p>During normal cycle execution</p>  <p>During test program</p>  	<p>Remaining Time</p> <p>During test program</p> <p><b>F03</b></p>	<p><b>Long Drain</b></p> <p>If the drain time exceeds the drain timeout, the LED "clean filter" is turned ON. The timeout is: 4 minutes drains -&gt; 4 minutes impulse draining (10sec.ON /10sec. OFF) -&gt; 4 minutes drain.</p> <p>The control is in Pause Mode. Press start button. If the water can be drained out, the cycle will continue.</p> <p><b>Potential Causes</b></p> <ul style="list-style-type: none"> <li>• Check the drain hose and make sure it is not plugged or kinked.</li> <li>• Check the drain pump filter for foreign objects.</li> <li>• Check the electrical connections at the pump and make sure the pump is running.</li> <li>• Check the electrical resistance of the drain pump.</li> <li>• The failure can also be generated by too much foam in wash phase. Read also failure description F18.</li> <li>• Check CCU operation.</li> </ul>
 	<p><b>F04</b></p>	<p><b>Too Long Heat Time</b></p> <p>If the water temperature is not increasing over 35 °C during 50 minutes of the first heating step in the cycle the CCU will display this Error.</p> <p><b>Potential Causes</b></p> <ul style="list-style-type: none"> <li>• Check the electrical resistance of the heating element.</li> <li>• Check Wire Harness connections to the heating element, NTC and CCU.</li> <li>• Check the electrical resistance of the NTC (failure can also occur, when NTC resistance is not changing with temperature).</li> <li>• Check CCU operation</li> </ul>
 	<p><b>F05</b></p>	<p><b>Water Temperature Sensor Error</b></p> <p>If during the water heating step in the wash cycle, the water temperature sensor (NTC) value is out of range, the F05 error code will be displayed.</p> <p><b>Potential Causes</b></p> <ul style="list-style-type: none"> <li>• Check the NTC resistance.</li> <li>• Check connections to the NTC and CCU.</li> </ul> <p>NTC short circuit (NTC or wiring to NTC): appliance is dead at switch on - read failure code from eeprom: class B failure (F60 - F63)</p>
 	<p><b>F06</b></p>	<p><b>Drive Motor Tachometer Error</b></p> <p>The control is unable to properly detect motor speed (several times) and the machine will shut down.</p> <p><b>Potential Causes</b></p> <ul style="list-style-type: none"> <li>• Check wire harness connections between the motor and CCU.</li> <li>• Check the resistance of the tachometer circuit on the motor.</li> <li>• Check resistances of the motor windings.</li> <li>• Check tension of belt and fixation of pulley.</li> </ul>
 	<p><b>F07</b></p>	<p><b>Motor Control Triac Error</b></p> <p>The main control has detected a short circuit in the motor control triac.</p> <p><b>Potential Causes</b></p> <ul style="list-style-type: none"> <li>• Check CCU by running Test Program: if failure occurs with universal motor: exchange CCU if failure occurs with CIM, BPM or Direct Drive: exchange motor control unit</li> </ul>
 	<p><b>F08</b></p>	<p><b>Heater Circuit Error open circuit</b></p> <p>The main control has detected a heater circuit failure. These failure modes are checked before the cycle starts and after the spinning steps.</p> <p><b>Potential Causes</b></p> <ul style="list-style-type: none"> <li>• Check the resistance of the heater connectors to the ground.</li> <li>• Check the resistance of the heater.</li> <li>• Check the wiring connectors to the heater and CCU.</li> <li>• Check the CCU.</li> </ul>

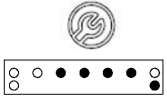

WAVE TCP & WAVE 2 ECO W10502177

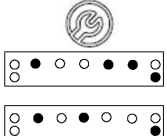
	<p>F09</p>	<p><b>MCU low voltage (only appliances with external motor control unit like CIM, BPM or Direct Drive)</b></p> <p>The MCU has detected a too low mains voltage (ca. 170V). It's not a defect of any component.</p> <p><b>Potential Causes</b></p> <ul style="list-style-type: none"> <li>• Check mains voltage supply</li> </ul>
	<p>F10</p>	<p><b>MCU overheat continuously (only appliances with external motor control unit like CIM, BPM or Direct Drive)</b></p> <p>The MCU has detected a too high temperature.</p> <p><b>Potential Causes</b></p> <ul style="list-style-type: none"> <li>• Check for drum blockage (also laundry can block the drum), noise or friction during the drum rotation</li> <li>• Check if the machine was overloaded</li> <li>• Check the ambient temperature -&gt; instruct the customer</li> </ul> <p><b>If the failure is permanent</b></p> <ul style="list-style-type: none"> <li>• Check motor for defect (see F06)</li> <li>• Check if motor control unit is defect</li> </ul>
	<p>F11</p>	<p><b>MCU not initialized / general MCU-failure (only appliances with external motor control unit like CIM, BPM or Direct Drive)</b></p> <p>The MCU failed during self-test.</p> <p><b>Potential Causes</b></p> <ul style="list-style-type: none"> <li>• Check harness wires between CCU and MCU and motor</li> <li>• Check motor for defect (see F06)</li> <li>• Start cycle door lock has to lock Relay for MCU on CCU has to close "click-noise" MCU self test starts automatically as soon as MCU is connected to voltage self-test was successful when relay on MCU switches - (can be recognized by click sound).</li> </ul>
	<p>F12</p>	<p><b>Heater Circuit Error short circuit</b></p> <p>The main control has detected a heater circuit failure. These failure modes are checked before the cycle starts and after the spinning steps.</p> <p><b>Potential Causes</b></p> <ul style="list-style-type: none"> <li>• Check the resistance of the heater connectors to the ground.</li> <li>• Check the resistance of the heater.</li> <li>• Check the wiring connectors to the heater and CCU.</li> <li>• Check the CCU.</li> </ul>
<p>Icon Door open is ON</p> 	<p>F13</p>	<p><b>CCU failure on door lock control circuit</b></p> <p>If CCU detects a defect of the door lock triac, F13 is displayed. This check is performed at start of cycle, during the cycle and at the end of the cycle.</p> <p>If CCU is not able to unlock the door at the end of program in 240 s this code will be displayed. After switch OFF and ON CCU will again try to open DL for 240 s - <b>all Leds and Display will be OFF</b> during this phase, <b>if again not successful Code will appear</b> after 240 s.</p> <p><b>Potential Causes</b></p> <ul style="list-style-type: none"> <li>• Check the wiring between the CCU and the door lock.</li> <li>• CCU defect</li> </ul>
	<p>F14</p>	<p><b>EEPROM Error</b></p> <p>The CCU receives its data from an EEPROM on board the CCU. If there is an error reading this data it will cause this failure indication.</p> <p><b>Potential Causes</b></p> <ul style="list-style-type: none"> <li>• A power glitch voltage variation or interruption (mains disturbance) may cause this error: Run the Test Program. This will perform a complete check of the EEPROM. If the failure is detected during the Test Program replace the CCU.</li> </ul>

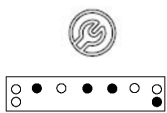
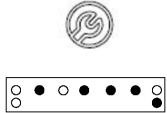
WAVE TCP & WAVE 2 ECO W10502177



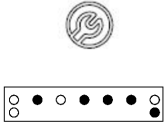
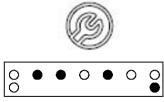
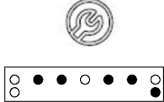

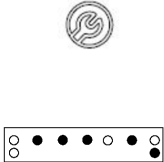
	<p><b>F15</b></p>	<p><b>Drum Up Circuit Missing (only for TOPLOADERS with DRUM UP Circuit)</b></p> <p>If the CCU is not detecting the Drum Up switch closing during Motor rotation this failure is displayed. This Error is detected ONLY during the Test Program.</p> <p><b>Potential Causes</b></p> <ul style="list-style-type: none"> <li>• Check the position of the electromagnetic device.</li> <li>• Check the position of the reed sensors.</li> <li>• Check the resistance of the reed sensor.</li> <li>• Check the wiring connection between the reed sensor and the CCU.</li> </ul>
	<p><b>F18 FoD</b></p>	<p><b>Foam detected During the Wash Cycle</b></p> <p>If the CCU is not able to drain out the water after washing or not able to spin after several trials this alarm code is displayed.</p> <p><b>Potential Causes</b></p> <ul style="list-style-type: none"> <li>• Customer used too much detergent.</li> <li>• Check if there is any problem with the pump hoses.</li> <li>• Check the pump for foreign objects.</li> <li>• Check the electrical resistance of the pump.</li> <li>• Check the electrical resistance of the pressure switch.</li> <li>• Check if pressure switch hose is in good condition and properly connected to tub and pressure switch.</li> <li>• Verify there is not a siphon problem.</li> </ul>
	<p><b>F19 F20</b></p>	<p><b>Relay for MCU on CCU is defect (only appliances with external motor control unit like CIM, BPM or Direct Drive)</b></p> <p>The central control unit has detected, that the relay to switch the MCU ON and OFF is defect (open or short circuit). The relay is placed on the CCU.</p> <p><b>Potential Causes</b></p> <ul style="list-style-type: none"> <li>• Check the wiring between CCU and MCU</li> </ul>
	<p><b>F21</b></p>	<p><b>User Interface Error (detected only with Smart user interfaces)</b></p> <p>If the communication between user interface module and CCU is disturbed, this Error is displayed. If the failure is displayed on the digits the display module is not able to "talk" to the CCU. If the failure is displayed on the status LED the CCU is not able to contact the Display module.</p> <p><b>Potential Causes</b></p> <ul style="list-style-type: none"> <li>• Check wiring connection to the display module.</li> <li>• Check display module.</li> <li>• Check CCU.</li> </ul>
	<p><b>F22</b></p>	<p><b>MCU communication failure (only appliances with external motor control unit like CIM, BPM or Direct Drive)</b></p> <p><b>Potential Causes</b></p> <ul style="list-style-type: none"> <li>• Check wiring /connection between MCU and CCU (communication wires)</li> <li>• Check MCU function</li> <li>• Check CCU function</li> </ul>
	<p><b>F23</b></p>	<p><b>Pressure switch Failure</b></p> <p>If the CCU detects during the wash cycle that the pressure switch contact for the wash level and the pressure switch level for the heater safety are ON or OFF simultaneously for 10" this failure will be displayed.</p> <p><b>Potential Causes</b></p> <ul style="list-style-type: none"> <li>• Check the resistance of the pressure switch contacts.</li> <li>• Check the wiring of the connection to the pressure switch and to the CCU.</li> <li>• Start the Test Program. If the problem persists F23 will be displayed.</li> <li>• Check points of F08 / F12 (Failure can be caused also by Heater circuit failure).</li> </ul>

WAVE TCP & WAVE 2 ECO W10502177

	<p>F24</p>	<p><b>Overflow Failure</b></p> <p>If the overflow contact on the pressure switch is closed, the drain pump is switched on for 45". The wash programs continue, if the overflow level is reached not more than 4x in a program. The overflow failure indication will occur, if the overflow contact is closed the 5<sup>th</sup> time. In overflow condition, the door will remain locked and the drain will run in interval mode.</p> <p><b>Potential Causes</b></p> <ul style="list-style-type: none"> <li>• Check the drain hose and make sure it is not plugged or kinked.</li> <li>• Check wiring harness connections between drain pump, pressure switch and CCU.</li> <li>• Check/clean drain pump filter of foreign objects.</li> <li>• Check for drain pump failure.</li> <li>• Check the inlet valve for proper shut off.</li> <li>• Check the pressure switch for proper operation.</li> </ul>
	<p>F26</p>	<p><b>Pump Driver Failure</b></p> <p>If the CCU detects during the wash cycle that the triac of the pump is defective it will display this failure.</p> <p><b>Potential Causes</b></p> <ul style="list-style-type: none"> <li>• Check the resistance of the pressure switch contacts.</li> <li>• A failure of the pressure switch could also cause the Code.</li> <li>• If OK. Start Service test to check the CCU. If the failure occurs replace the CCU.</li> </ul>
<p>Only during test program</p> 	<p>Only during test program</p> <p>F27</p>	<p><b>Reversing relay failure</b></p> <p>If the CCU detects that the motor is possible to rotate only in one direction this failure is displayed.</p> <p><b>Potential Causes</b></p> <ul style="list-style-type: none"> <li>• Check the harness to the motor.</li> <li>• Check the CCU.</li> </ul>
<p>Only during test program</p> 	<p>Only during test program</p> <p>F28</p>	<p><b>Tapped Field Failure</b></p> <p>If the CCU is not able to switch ON the tapped field of the Motor, this failure code is displayed.</p> <p><b>Potential Causes</b></p> <ul style="list-style-type: none"> <li>• Check if the correct motor is built in.</li> <li>• Check the resistance of the fields of the motor.</li> <li>• Check the harness between Motor and CCU.</li> <li>• If the points above are OK replace the CCU.</li> </ul>
	<p>F29 OR FdL</p>	<p><b>Door Lock can not unlock, mechanical issue of door lock blockage,..</b></p> <p><b>Potential Causes</b></p> <ul style="list-style-type: none"> <li>• Check if there is a mechanical problem on the door lock system (also door and door hook)</li> <li>• Check wiring between the CCU and the door lock.</li> <li>• Start the test program. If problem persists the error code F29 or FdL will be displayed</li> </ul> <p><b>WAVE TCP:</b> Door lock timeout is 4 minutes, but can be expired 2x within the last 16 cycles. If 3<sup>rd</sup> occurrence within 16 cycles: F29 or FdL is displayed The appliance is locked during the failure mode. The appliance can start a new cycle without waiting for unlocking. For unloading the laundry, the customer must wait for unlocking (ca. 4minutes).</p> <p><b>IMPORTANT: The failure indication can be deleted only by running the test program (completely!) or by reprogramming the variant file.</b></p> <p><b>WAVE 2:</b> Door lock timeout is increased to 6minutes F29 or FdL is indicated at 1<sup>st</sup> occurrence. The door lock is not locked during failure conditions. It is not necessary to delete the failure.</p>

WAVE TCP & WAVE 2 ECO W10502177



	<p><b>F31</b> or <b>bdd</b></p>	<p><b>Blocked Drum Detected (only for Top Loader appliances)</b></p> <p>CCU detects problems with driving of the motor at the beginning of the cycle or after pause mode when door lock has been unlocked.</p> <p><b>Potential Causes</b></p> <ul style="list-style-type: none"> <li>• Check if the drum door are properly closed</li> <li>• Check the belt position</li> <li>• Check the F06 case</li> </ul>
	<p><b>Only during test program</b></p> <p><b>F40</b></p>	<p><b>MEB Communication Failure / Low Ambient Temperature</b></p> <p>If there is no communication between CCU and the Myst Extension Board (MEB) or if the ambient temperature is lower than 5 °C this failure code will be displayed.</p> <p><b>Potential Causes</b></p> <ul style="list-style-type: none"> <li>• Check if there is power at the MEB CU2 connector.</li> <li>• Check if the communication cable is connected to the MEB and to the UI.</li> <li>• Check if the ambient temperature is higher than 5 °C. This is to avoid steaming with ice in the hoses, which would easily cause damages of the hoses.</li> <li>• If the failure code occurs at star of test program, the last cycle was not properly finished. Run a drain cycle, wait until drain cycle is completely finished and start test program again.</li> <li>• If the points above are OK and the failure occurs again, replace the MEB.</li> </ul>
	<p><b>Only during test program</b></p> <p><b>F41</b></p>	<p><b>MEB Control Board Failure</b></p> <p>If there is any failure detected at the Myst Extension Board (MEB) this failure code will be displayed.</p> <p><b>Potential Causes</b></p> <ul style="list-style-type: none"> <li>• Check if there is power at the MEB CU2 connector.</li> <li>• If the point above is OK replace the MEB.</li> </ul>
	<p><b>Only during test program</b></p> <p><b>F42</b></p>	<p><b>Steamer Component Failure</b></p> <p>If there is any failure at the steamer component or steamer NTC, this failure Code will be displayed.</p> <p><b>Potential Causes</b></p> <p>Disconnect appliance from mains for all checks on steamer:</p> <ul style="list-style-type: none"> <li>• Check the harness between Steamer, steamer NTC and MEB.</li> <li>• Check if there is no fuse or reset able thermostat at open state.</li> <li>• Check the electrical resistance of the Steamer Heater (unplug connector HSG3 from MEB measure resistance between pin 1 and 3: ca. 48-57Ohm - measure at harness connector and not at MEB header).</li> <li>• Check if the steamer NTC is not at open or short-circuit state.</li> <li>• Check if the steamer hoses are connected.</li> <li>• Check if the steamer tube is not blocked.</li> <li>• Check water NTC (in wash unit) and wiring connections (see F04 and F05)</li> <li>• If the points above are OK replace the steamer component.</li> </ul>
	<p><b>Only during test program</b></p> <p><b>F43</b></p>	<p><b>Steam Valve Failure</b></p> <p>If there is no water supply or the steamer valve does not open, this failure code will be displayed.</p> <p><b>Potential Causes</b></p> <ul style="list-style-type: none"> <li>• Check if water supply for the appliance is completely opened.</li> <li>• Check the cable between MEB and valve.</li> <li>• Check power supply from MEB to valve (230V).</li> <li>• Check if the hoses to the valve are connected with no leakage.</li> <li>• If the points above are OK replace the valve.</li> <li>• Re-test the machine and if the failure persists replace the MEB.</li> </ul>

**Domino Class B safety functions:**

- 1) **Wash Level activated during selection mode:**  
The Door is locked and Drain routine is started. If the Drain Pump is not defective the Door will be unlocked after Level N0 + 30 seconds;  
Led (display) status: normal indication  
If Drain Pump is defective Pump failure will be retriven.
- 2) **Drum Speed is higher than 60rpm in selection mode:**  
When the speed > 60 rpm, then after 4 seconds, the doorlock is activated.  
Led (display) status: normal indication
- 3) **Water High Temperature in selection or pause mode:**  
If temperature which NTC sensor is detecting is higher than 50 °C Door Lock will kept locked.  
Led (display) status: normal indication

WAVE TCP & WAVE 2 ECO W10502177