

TDA 2025 50 Watt Power Amplifier

Pin Configuration		Pin Definitions	
		Pin	Function
		1	Non-Inverting Output
2	Input		
3	V _S		
4	Power Ground		
5	Hum Suppression		
6	Pre-Stage Ground		
7	Inverting Output		

The TDA 2025 is a 20W to 50W watt power amplifier for Automotive and Entertainment applications featuring full protection from external thermal and electrical malfunctions.

The IC combines 2 complete power amplifiers configured as a class A-B bridge. The integrated resistor network in the positive and negative feedback loops set the gain for each amplifier to 30 dB. The inputs for the inverting and non-inverting gain (pre-amp) stages are tied in parallel resulting in a full bridge configuration with 36 dB of gain and superior "switch-on"/"switch-off" characteristics.

The output power drivers are designed to drive either 4Ω ($V_S < 24V$) or 8Ω ($V_S < 45V$) speakers at currents up to 4A.

An internal hum suppression circuit using an external capacitor is also available at pin 5 with 100 μF at 3V used as a typical value.

The output driver stages are short circuit protected to both ground and V_S , and an internal thermal "fuse" circuit protects the output stage against thermal damage.

An internal DC protection circuit prevents speaker overload if one output is shorted to ground.

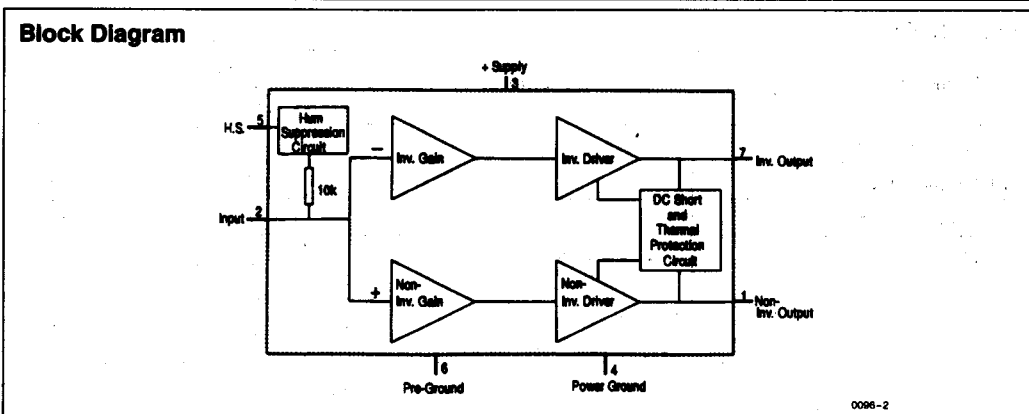

Absolute Maximum Ratings*

Supply Voltage (V_S) 0.3V to 45V
 Output Current ($I_{1, 7}$) - 4.0A to + 4.0A
 Input Voltage (Pin 5) (V_5) - 0.3V to 6.0V
 Input Voltage (Pin 2) (V_2) - 0.3V to V_S
 Junction Temperature (T_j) + 150°C
 Storage Temperature (T_{stg}) - 50°C to + 150°C

*Stresses above those listed under "Absolute Maximum Ratings" may cause permanent damage to the device. Exposure to absolute maximum rating conditions for extended periods may affect device reliability.

Caution

Exceeding absolute maximum ratings may result in irreversible damage to the integrated circuit.

Recommended Operating Range

Parameter	Symbol	Conditions	Limits		Units
			Min	Max	
Supply Voltage	V_S		8	42	V
Case Temperature	T_c	$P_V = 25W$	- 25	+ 75	°C
Thermal Resistance	R_{thSC}			3	K/W

Characteristics

Parameter	Symbol	Conditions	Limits			Units
			Min	Typ	Max	
Quiescent Current	I_S	S3 Open		40	60	mA
Differential Output	V_D			± 0.5		V
Input Impedance	R_i			10		k Ω
Output Power	P_q	$V_S = 14.4V$; $R_L = 4\Omega$; THD = 1%	12	15		W
	P_q	$V_S = 14.4V$; $R_L = 4\Omega$; THD = 10%	18	20		W
	P_q	$V_S = 32V$; $R_L = 8\Omega$; THD = 1%	36	40		W
	P_q	$V_S = 32V$; $R_L = 8\Omega$; THD = 10%	45	50		W
Hum Suppression	a_{SVR}	S1 pos. 2, S2 closed	37	40		dB
Supply Current	I_S	$P_q = 50W$, $f = 1$ KHz		2.3		A
Efficiency	η	$P_q = 50W$, $f = 1$ KHz		70		%
Total Harmonic Distortion	THD	$P_q = 0.1W$ to 30W, $f = 40$ Hz to 15 KHz		0.2		%
Power Bandwidth	B	$P_q = 30W$, -3 dB at 1 KHz	20 Hz to 50 KHz			
Noise	V_n	DIN 45405, S2 Closed		5		μV
Voltage Gain	A_V	$R_L = 8\Omega$, $P_q = 10W$	34	36	38	dB
Output Protection (Activation Level)	$V_{1(7)}$	Pin 1 or 7 shorted to GND and $V_S > 10V$		0.25	0.5	V

The Characteristics listed above are ensured over the operating range of the TDA 2025. Typical Characteristics specify mean values expected over the production spread. Typical characteristics apply to $T_a = 25^\circ C$ at mean supply voltage unless otherwise stated.

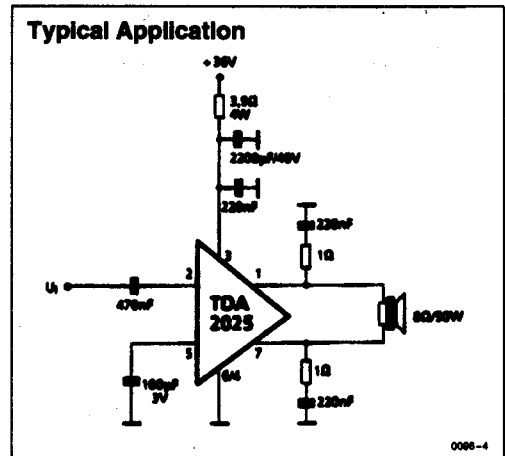
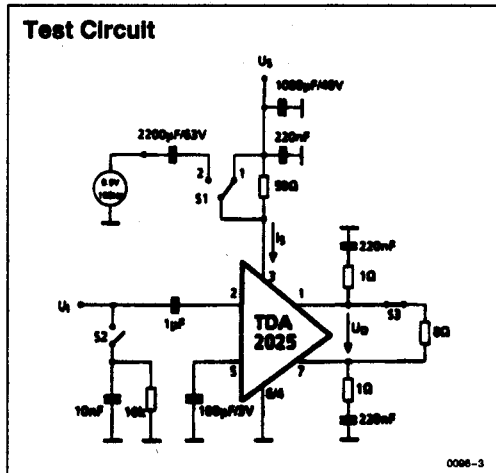

Performance Characteristics

Test Conditions: Frequency = 1 KHz, Load Resistance = 4Ω

V_s (V)	I_s (A)	P_v (W)	P_q (W)	n (%)	THD (%)
8.06	0.453	2.64	3.65	28	0.10
8.02	0.801	3.24	6.42	50	0.59
8.02	0.835	3.23	6.69	52	0.99
8.01	0.940	3.19	7.53	58	5.01
8.00	0.997	3.20	7.98	60	10.02
14.46	1.448	10.43	20.93	50	0.12
14.44	1.630	10.12	23.53	57	0.59
14.43	1.677	10.10	24.20	58	0.99
14.42	1.830	9.81	26.38	63	5.00
14.40	1.942	9.66	27.98	65	10.01
22.15	1.742	23.60	38.59	39	0.11
22.09	2.316	24.39	51.17	52	0.59
22.09	2.368	24.31	52.31	54	0.99
22.07	2.562	24.10	56.54	57	4.99
22.05	2.725	24.02	60.10	60	10.01

Note: $V_s = 24V$ Max. with $R_L = 4\Omega$.

Test Conditions: Frequency = 1 KHz, Load Resistance = 8Ω

V_s (V)	I_s (A)	P_v (W)	P_q (W)	n (%)	THD (%)
28.06	1.512	19.93	42.43	53	0.05
28.03	1.735	18.66	42.64	62	0.12
28.02	1.880	17.33	52.68	67	0.99
28.00	2.016	16.21	56.44	71	5.00
27.99	2.135	15.33	59.76	74	10.01
32.15	1.613	26.87	51.86	48	0.04
32.12	1.888	25.62	60.63	58	0.10
32.09	2.140	23.08	68.66	66	0.99
32.07	2.281	21.75	73.15	70	5.00
32.06	2.423	20.56	77.67	74	10.00
36.15	1.787	34.57	64.62	46	0.05
36.12	2.033	33.47	73.45	54	0.10
36.09	2.357	29.90	85.06	65	0.99
36.07	2.510	28.20	90.53	69	4.99
36.06	2.667	26.70	96.18	72	9.99

Note: $V_s = 45V$ Max. with $R_L = 8\Omega$.

Power Dissipation vs Output Power

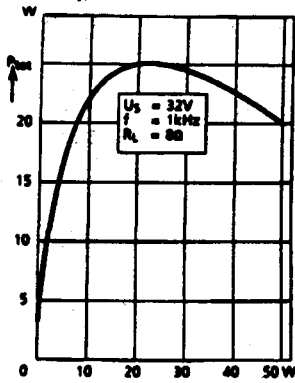

Efficiency vs Output Power

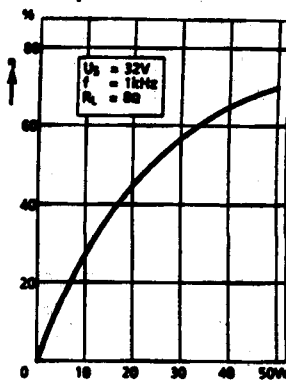

Quiescent Current vs Power Supply Voltage

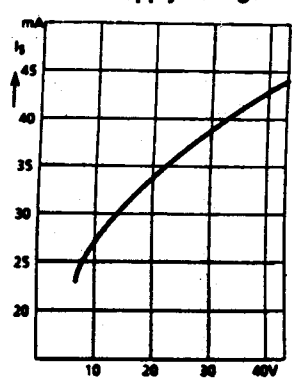

0096-6

THD vs Output Power

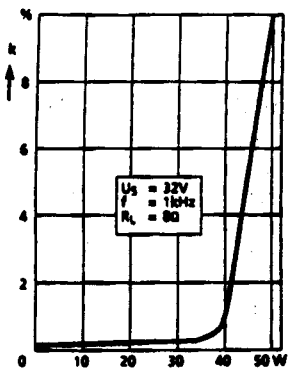

Supply Current vs Output Power

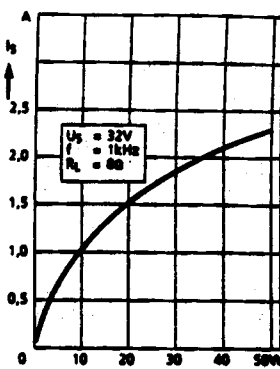

Output Power vs Power Supply Voltage

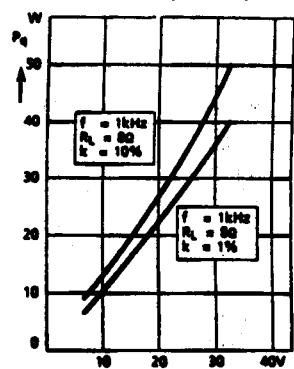

0096-7

THD vs Frequency

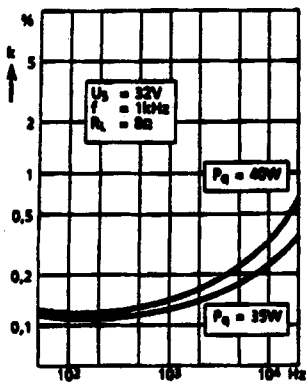

Hum Suppression vs Frequency

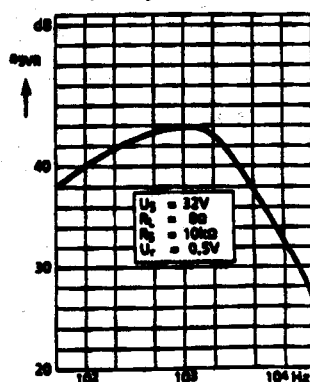

0096-8

Ordering Information

Type	Ordering Code	Package
TDA 2025	Q67000-A8186	TO220/7

This datasheet has been downloaded from:

www.DatasheetCatalog.com

Datasheets for electronic components.