

# DATA SHEET

## **TDA8440** Switch for CTV receivers

Product specification  
File under Integrated Circuits, IC02

November 1985

## Switch for CTV receivers

TDA8440

**GENERAL DESCRIPTION**

The TDA8440 is a versatile video/audio switch, intended to be used in CTV receivers equipped with an AUXILIARY VIDEO/AUDIO plug.

It provides two 3-state switches for audio channels and one 3-state switch for the video channel and a video amplifier with selectable gain (times 1 or times 2).

The integrated circuit can be used in conjunction with a microcontroller from the MAB8400 family, and is controlled via a bidirectional I<sup>2</sup>C bus. Sufficient sub-addressing is provided for the I<sup>2</sup>C bus mode. It can also be controlled directly by d.c. switching signals.

**Features**

- Combined analogue and digital circuitry gives maximum flexibility in channel switching
- 3-state switches for all channels
- Selectable gain for the video channels
- Sub-addressing facility
- I<sup>2</sup>C bus or non-I<sup>2</sup>C bus mode (controlled by d.c. voltages)
- Slave receiver in the I<sup>2</sup>C bus mode
- External OFF command
- System expansion possible up to 7 devices (14 sources)
- Static short-circuit proof outputs

**QUICK REFERENCE DATA**

Supply voltage range	$V_{15-4}$	10 to 13,2 V
Supply current (without load)	$I_{15}$	typ. 33 mA
		max. 50 mA
Storage temperature	$T_{stg}$	max. + 125 °C
Operating ambient temperature range	$T_{amb}$	0 to + 70 °C

**PACKAGE OUTLINE**

18-lead DIL; plastic (SOT102); SOT102-1; 1996 November 19.

Switch for CTV receivers

TDA8440

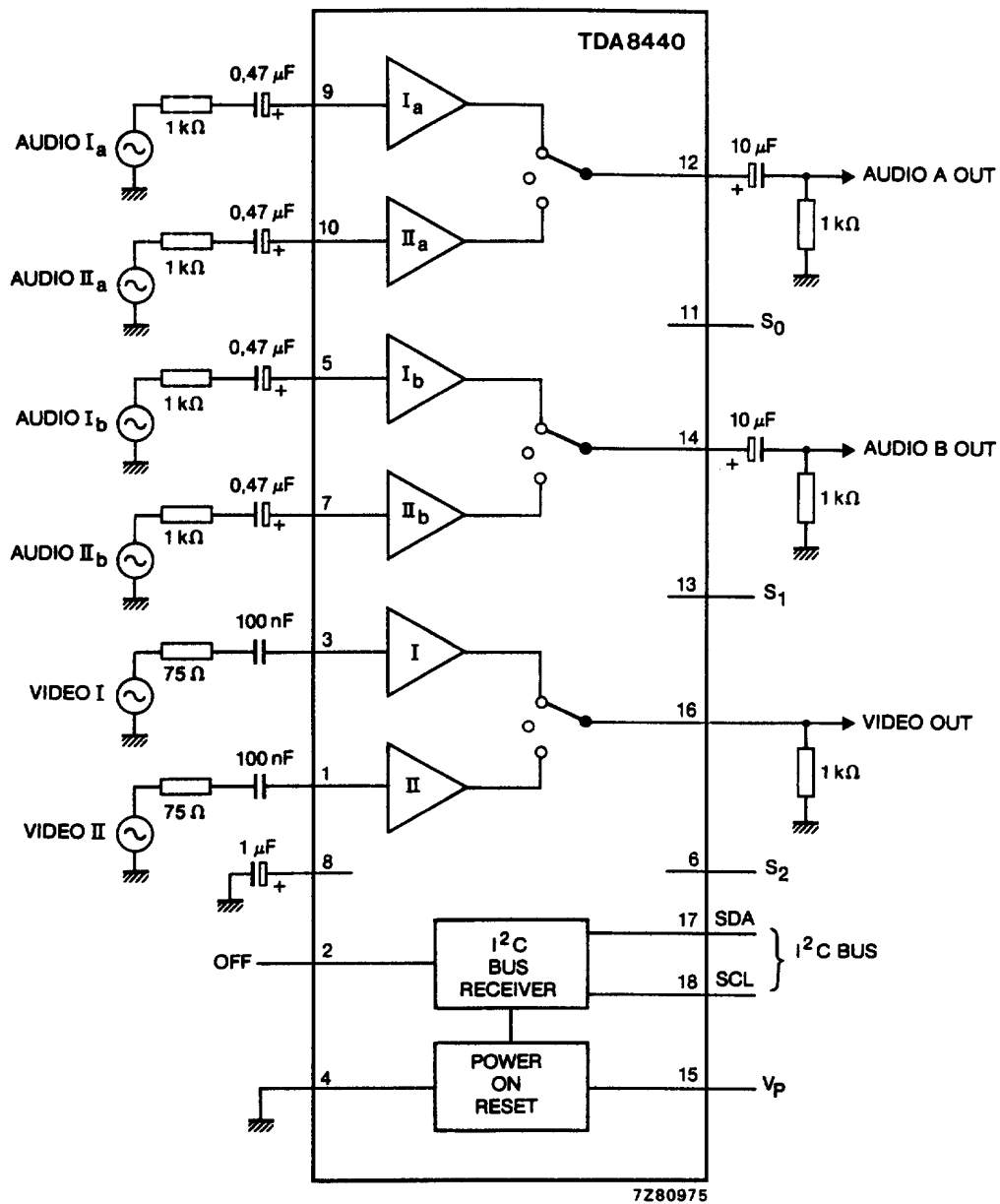

S<sub>0</sub>, S<sub>1</sub>, S<sub>2</sub> and OFF (pins 11, 13, 6 and 2) connected to V<sub>P</sub> or GND.  
 If more than 1 device is used, then the outputs and the pins 8 (bias decoupling of the audio inputs) may be connected in parallel.

Fig.1 Block diagram and test circuit.

## Switch for CTV receivers

TDA8440

**FUNCTIONAL DESCRIPTION**

The TDA8440 is a monolithic system of switches and can be used in CTV receivers equipped with an AUXILIARY VIDEO/AUDIO plug.

The IC incorporates 3-state switches; they comprise:

- a) An electronic video switch with selectable gain (times 1 or times 2) for switching between an internal video signal (from the IF amplifier) and an AUXILIARY input signal.
- b) Two electronic audio switches, for two sound channels (stereo or dual language), for switching between internal audio sources and signals from the AUXILIARY VIDEO/AUDIO plug.

A selection can be made between two input signals and an OFF-state. The OFF-state is necessary if more than one TDA8440 device is used.

The SDA and SCL pins can be connected to the I<sup>2</sup>C bus or to d.c. switching voltages. Inputs S<sub>0</sub> (pin 11), S<sub>1</sub> (pin 13), and S<sub>2</sub> (pin 6) are used for selection of sub-addresses or switching to the non-I<sup>2</sup>C mode. Inputs S<sub>0</sub>, S<sub>1</sub> and S<sub>2</sub> can be connected to the supply voltage (H) or to ground (L). In this way no peripheral components are required for selection.

**Table 1** Sub-addressing

S <sub>2</sub>	S <sub>1</sub>	S <sub>0</sub>	SUB-ADDRESS		
			A <sub>2</sub>	A <sub>1</sub>	A <sub>0</sub>
L	L	L	0	0	0
L	L	H	0	0	1
L	H	L	0	1	0
L	H	H	0	1	1
H	L	L	1	0	0
H	L	H	1	0	1
H	H	L	1	1	0
H	H	H	non I <sup>2</sup> C addressable		

**NON-I<sup>2</sup>C BUS CONTROL**

If the TDA8440 switching device has to be operated via the AUXILIARY VIDEO/AUDIO plug, inputs S<sub>2</sub>, S<sub>1</sub> and S<sub>0</sub> must be connected to the supply line (12 V).

The sources (internal and external) and the gain of the video amplifier can be selected via the SDA and SCL pins with the switching voltage from the AUXILIARY VIDEO/AUDIO plug:

- Sources I are selected if SDA = 12 V (external source)
- Sources II are selected if SDA = 0 V (TV mode)
- Video amplifier gain is 2 × if SCL = 12 V (external source)
- Video amplifier gain is 1 × if SCL = 0 V (TV mode)

If more than one TDA8440 device is used in the non-I<sup>2</sup>C bus system, the OFF pin can be used to switch off the desired devices. This can be done via the 12 V switching voltage on the AUXILIARY VIDEO/AUDIO plug.

- All switches are in the OFF position if OFF = H (12 V)
- All switches are in the selected position via SDA and SCL pins if OFF = L (0 V)

# Switch for CTV receivers

# TDA8440

## I<sup>2</sup>C BUS CONTROL

Detailed information on the I<sup>2</sup>C bus is available on request.

**Table 2** TDA8440 I<sup>2</sup>C bus protocol.

STA	A <sub>6</sub>	A <sub>5</sub>	A <sub>4</sub>	A <sub>3</sub>	A <sub>2</sub>	A <sub>1</sub>	A <sub>0</sub>	R/W	AC	D <sub>7</sub>	D <sub>6</sub>	D <sub>5</sub>	D <sub>4</sub>	D <sub>3</sub>	D <sub>2</sub>	D <sub>1</sub>	D <sub>0</sub>	AC	STO
-----	----------------	----------------	----------------	----------------	----------------	----------------	----------------	-----	----	----------------	----------------	----------------	----------------	----------------	----------------	----------------	----------------	----	-----

- STA = start condition
- A<sub>6</sub> = 1 Fixed address bits
- A<sub>5</sub> = 0 Fixed address bits
- A<sub>4</sub> = 0 Fixed address bits
- A<sub>3</sub> = 1 Fixed address bits
- A<sub>2</sub> = sub-address bit, fixed via S<sub>2</sub> input
- A<sub>1</sub> = sub-address bit, fixed via S<sub>1</sub> input
- A<sub>0</sub> = sub-address bit, fixed via S<sub>0</sub> input
- R/W = read/write bit (has to be 0, only write mode allowed)
- AC = acknowledge bit (= 0) generated by the TDA8440
- D<sub>7</sub> = 1 audio Ia is selected to audio output a
- D<sub>7</sub> = 0 audio Ia is not selected
- D<sub>6</sub> = 1 audio IIa is selected to audio output a
- D<sub>6</sub> = 0 audio IIa is not selected
- D<sub>5</sub> = 1 audio Ib is selected to audio output b
- D<sub>5</sub> = 0 audio Ib output is not selected
- D<sub>4</sub> = 1 audio IIb is selected to audio output b
- D<sub>4</sub> = 0 audio IIb is not selected
- D<sub>3</sub> = 1 video I is selected to video output
- D<sub>3</sub> = 0 video I is not selected
- D<sub>2</sub> = 1 video II is selected to video output
- D<sub>2</sub> = 0 video II is not selected
- D<sub>1</sub> = 1 video amplifier gain is times 2
- D<sub>1</sub> = 0 video amplifier gain is times 1
- D<sub>0</sub> = 1 OFF-input inactive
- D<sub>0</sub> = 0 OFF-input active
- STO = stop condition

## OFF FUNCTION

With the OFF input all outputs can be switched off (mode high ohmic), depending on the value of D<sub>0</sub>.

## Switch for CTV receivers

TDA8440

**D<sub>0</sub>/OFF gating**

D <sub>0</sub>	OFF INPUT	OUTPUTS
0 (off input active)	H	OFF
0	L	in accordance with last defined D <sub>7</sub> - D <sub>1</sub> (may be entered while OFF = HIGH)
1 (off input inactive)	H	in accordance with D <sub>7</sub> - D <sub>1</sub>
1	L	in accordance with D <sub>7</sub> - D <sub>1</sub>

**Power-on reset**

The circuit is provided with a power-on reset function.

When the power supply is switched on an internal pulse will be generated that will reset the internal memory S<sub>0</sub>, in the initial state all the switches will be in the off position and the OFF input is active (D<sub>7</sub> - D<sub>0</sub> = 0) (I<sup>2</sup>C mode), position defined via SDA and SCL inputs (non-I<sup>2</sup>C mode).

When the power supply decreases below 5 V a pulse will be generated and the internal memory will be reset. The behaviour of the switches will be the same as described above.

**RATINGS**

Limiting values in accordance with the Absolute Maximum System (IEC 134)

		MIN.	TYP.	MAX.	UNIT
Supply voltage	pin 15 V <sub>P</sub>	–	–	14	V
Input voltage range	pin 17 V <sub>SDA</sub>	–0,3	–	V <sub>P</sub> + 0,3	V
	pin 18 V <sub>SCL</sub>	–0,3	–	V <sub>P</sub> + 0,3	V
	pin 2 V <sub>OFF</sub>	–0,3	–	V <sub>P</sub> + 0,3	V
	pin 11 V <sub>S0</sub>	–0,3	–	V <sub>P</sub> + 0,3	V
	pin 13 V <sub>S1</sub>	–0,3	–	V <sub>P</sub> + 0,3	V
	pin 6 V <sub>S2</sub>	–0,3	–	V <sub>P</sub> + 0,3	V
	Video output current	pin 16 –I <sub>16</sub>	–	–	50
Storage temperature range	T <sub>stg</sub>	–	–	+ 125	°C
Operating ambient temperature range	T <sub>amb</sub>	0	–	+ 70	°C
Junction temperature	T <sub>j</sub>	–	–	+ 150	°C

**THERMAL RESISTANCE**

PARAMETER	SYMBOL	VALUE	UNIT
From junction to ambient in free air	R <sub>thj-a</sub>	50	K/W

## Switch for CTV receivers

## TDA8440

**CHARACTERISTICS**T<sub>amb</sub> = 25 °C; V<sub>p</sub> = 12 V; unless otherwise specified

PARAMETER	SYMBOL	MIN.	TYP.	MAX.	UNIT
<b>Supply</b>					
Supply voltage	V <sub>15-4</sub>	10	–	13,2	V
Supply current (without load)	I <sub>15</sub>	–	37	50	mA
<b>Video switch</b>					
Input coupling capacitor	C <sub>1</sub> C <sub>3</sub>	100	–	–	nF
Voltage gain (times 1; SCL = L)	A <sub>3-16</sub>	–1	0	+1	dB
(times 2; SCL = H)	A <sub>3-16</sub>	+5	+6	+7	dB
Voltage gain (times 1; SCL = L)	A <sub>1-16</sub>	–1	0	+1	dB
(times 2; SCL = H)	A <sub>1-16</sub>	+5	+6	+7	dB
Input video signal amplitude (gain times 1)	V <sub>3-4</sub>	–	–	4,5	V
Input video signal amplitude (gain times 1)	V <sub>1-4</sub>	–	–	4,5	V
Output impedance	Z <sub>16-4</sub>	–	7	–	Ω
Output impedance in 'OFF' state	Z <sub>16-4</sub>	100	–	–	kΩ
Isolation (off state) (f <sub>o</sub> = 5 MHz)		60	–	–	dB
Signal-to-noise ratio (note 3)	S/S + N	60	–	–	dB
Output top-sync level	V <sub>16-4</sub>	2,4	2,8	3,2	V
Differential gain	G	–	–	3	%
Minimum crosstalk attenuation (note 2)	V <sub>16-4</sub>	60	–	–	dB
Supply voltage rejection (note 4)	RR	36	–	–	dB
Bandwidth (1 dB)	B	10	–	–	MHz
Crosstalk attenuation for interference caused by bus signals (source impedance 75 Ω)	α	60	–	–	dB
<b>Audio switch a and b</b>					
Input signal level	V <sub>9-4(rms)</sub>	–	–	2	V
	V <sub>10-4(rms)</sub>	–	–	2	V
	V <sub>5-4(rms)</sub>	–	–	2	V
	V <sub>7-4(rms)</sub>	–	–	2	V
Input impedance	Z <sub>9-4</sub>	50	100	–	kΩ
	Z <sub>10-4</sub>	50	100	–	kΩ
	Z <sub>5-4</sub>	50	100	–	kΩ
	Z <sub>7-4</sub>	50	100	–	kΩ
Output impedance	Z <sub>12-4</sub>	–	–	10	Ω
	Z <sub>14-4</sub>	–	–	10	Ω
Output impedance (off state)	Z <sub>14-4</sub>	100	–	–	kΩ

## Switch for CTV receivers

## TDA8440

PARAMETER	SYMBOL	MIN.	TYP.	MAX.	UNIT
Voltage gain	$V_{9-12}$	-1	0	+1	dB
	$V_{10-12}$	-1	0	+1	dB
	$V_{5-14}$	-1	0	+1	dB
	$V_{7-14}$	-1	0	+1	dB
Isolation (off state) (f = 20 kHz)		90	-	-	dB
Signal-to-noise ratio (note 5)	S/S + N	90	-	-	dB
Total harmonic distortion (note 7)	THD	-	-	0,1	%
Crosstalk attenuation for interferences caused by video signals (note 6)					
Weighted	$\alpha$	80	-	-	dB
Unweighted	$\alpha$	80	-	-	dB
Crosstalk attenuation for interferences caused by sinusoidal sound signals (note 6)	$\alpha$	80	-	-	dB
Crosstalk attenuation for interferences caused by the bus signal (weighted) (source impedance = 1 k $\Omega$ )		80	-	-	dB
Supply voltage rejection	RR	50	-	-	dB
Bandwidth (-1 dB)	B	50	-	-	kHz
<b>I<sup>2</sup>C bus inputs/outputs SDA (pin 17) and SCL (pin 18)</b>					
Input voltage HIGH	$V_{IH}$	3	-	$V_P$	V
Input voltage LOW	$V_{IL}$	-0,3	-	+ 1,5	V
Input current HIGH <sup>(1)</sup>	$I_{IH}$	-	-	10	$\mu$ A
Input current LOW <sup>(1)</sup>	$I_{IL}$	-	-	10	$\mu$ A
Output voltage LOW at $I_{OL} = 3$ mA	$V_{OL}$	-	-	0,4	V
Maximum output sink current	$I_{OL}$	-	5	-	mA
Capacitance of SDA and SDL inputs, pins 17 and 18	$C_1$	-	-	10	pF
<b>Sub-address inputs <math>S_0</math> (pin 11), <math>S_1</math> (pin 13), <math>S_2</math> (pin 6)</b>					
Input voltage HIGH	$V_{IH}$	3	-	$V_P$	V
Input voltage LOW	$V_{IL}$	-0,3	-	+ 0,4	V
Input current HIGH	$I_{IH}$	-	-	10	$\mu$ A
Input current LOW	$I_{IL}$	-50	-	0	$\mu$ A
<b>OFF input (pin 2)</b>					
Input voltage HIGH	$V_{IH}$	+3	-	$V_P$	V
Input voltage LOW	$V_{IL}$	-0,3	-	+ 0,4	V
Input current HIGH	$I_{IH}$	-	-	20	$\mu$ A
Input current LOW	$I_{IL}$	-10	-	2	$\mu$ A



## Switch for CTV receivers

## TDA8440

PARAMETER	SYMBOL	MIN.	TYP.	MAX.	UNIT
Bus free before start <sup>(11)</sup>	$t_{BUF}$	4	—	—	$\mu\text{s}$
Start condition set-up time	$t_{S(STA)}$	4	—	—	$\mu\text{s}$
Start condition hold time	$t_{H(STA)}$	4	—	—	$\mu\text{s}$
SCL, SDA LOW period	$t_{LOW}$	4	—	—	$\mu\text{s}$
SCL, HIGH period	$t_{HIGH}$	4	—	—	$\mu\text{s}$
SCL, SDA rise time	$t_r$	—	—	1	$\mu\text{s}$
SCL, SDA fall time	$t_f$	—	—	0,3	$\mu\text{s}$
Data set-up time (write)	$t_{S(DAT)}$	1	—	—	$\mu\text{s}$
Data hold time (write)	$t_{H(DAT)}$	1	—	—	$\mu\text{s}$
Acknowledge (from TDA8440) set-up time	$t_{S(CAC)}$	—	—	2	$\mu\text{s}$
Acknowledge (from TDA8440) hold time	$t_{H(CAC)}$	0	—	—	$\mu\text{s}$
Stop condition set-up time	$t_{S(STO)}$	4	—	—	$\mu\text{s}$

**Notes to the characteristics**

- Also if the supply is switched off.
- Caused by drive on any other input at maximum level, measured in  $B = 5 \text{ MHz}$ , source impedance for the used input  $75 \Omega$ ,
 
$$\text{crosstalk} = 20 \log \frac{V_{out}}{V_{IN \max}}$$
- $$S/N = 20 \log \frac{V_O \text{ video noise (p-p) (2 V)}}{V_O \text{ noise rms } B = 5 \text{ MHz}}$$
- Supply voltage ripple rejection =  $20 \log \frac{V_r \text{ supply}}{V_r \text{ on output}}$  at  $f = \text{max. } 100 \text{ kHz}$ .
- $$S/N = 20 \log \frac{V_O \text{ nominal (0,5 V)}}{V_O \text{ noise } B = 20 \text{ kHz}}$$
- Caused by drive of any other input at maximum level, measured in  $B = 20 \text{ kHz}$ , source impedance of the used input =  $1 \text{ k}\Omega$ ,
 
$$\text{crosstalk} = 20 \log \frac{V_{out}}{V_{in \max}}$$
 according to DIN 45405 (CCIR 468).
- $f = 20 \text{ Hz to } 20 \text{ kHz}$ .
- All outputs are short-circuit proof (static).
- The inputs and output (apart from SDA, SCL and OFF) withstand tests of MIL-STD-883 C. It is advisable to connected series resistors to these pins.
- Timings  $t_{S, DAT}$  and  $t_{H, DAT}$  deviate from the I<sup>2</sup>C bus specification. After reset has been activated, transmission may only be started after a  $50 \mu\text{s}$  delay.
- I<sup>2</sup>C bus load conditions are as follows:  
 $4\text{k}\Omega$  pull-up resistor to  $+5 \text{ V}$ ;  $200 \text{ pF}$  to GND.  
 All values are referred to  $V_{IH} = 3 \text{ V}$  and  $V_{IL} = 1,5 \text{ V}$ .

Switch for CTV receivers

TDA8440

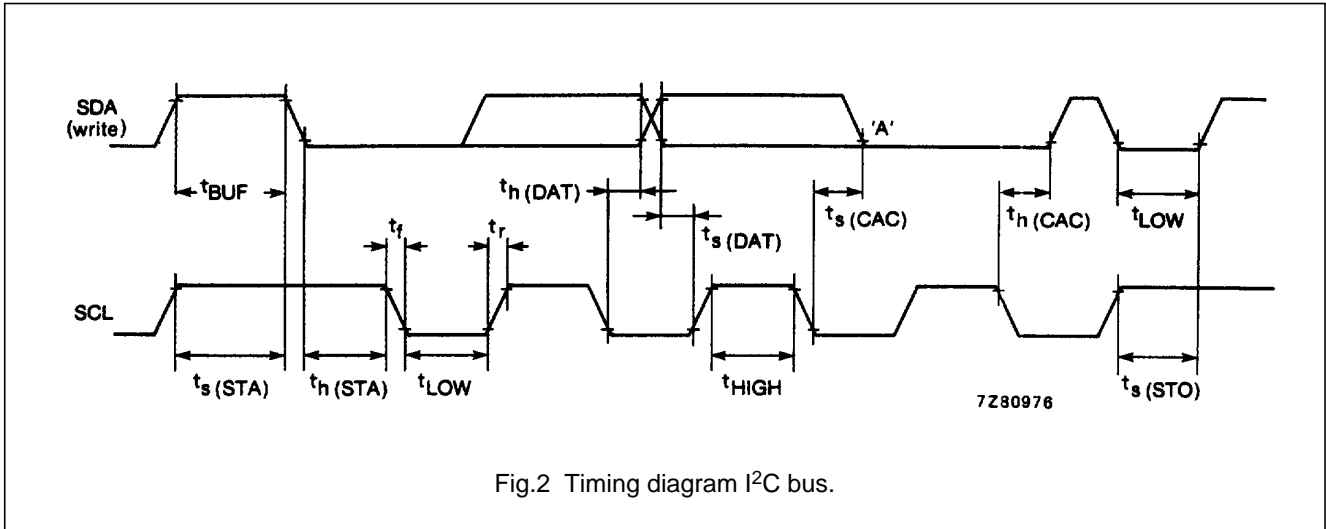

Switch for CTV receivers

TDA8440

PACKAGE OUTLINE

DIP18: plastic dual in-line package; 18 leads (300 mil)

SOT102-1

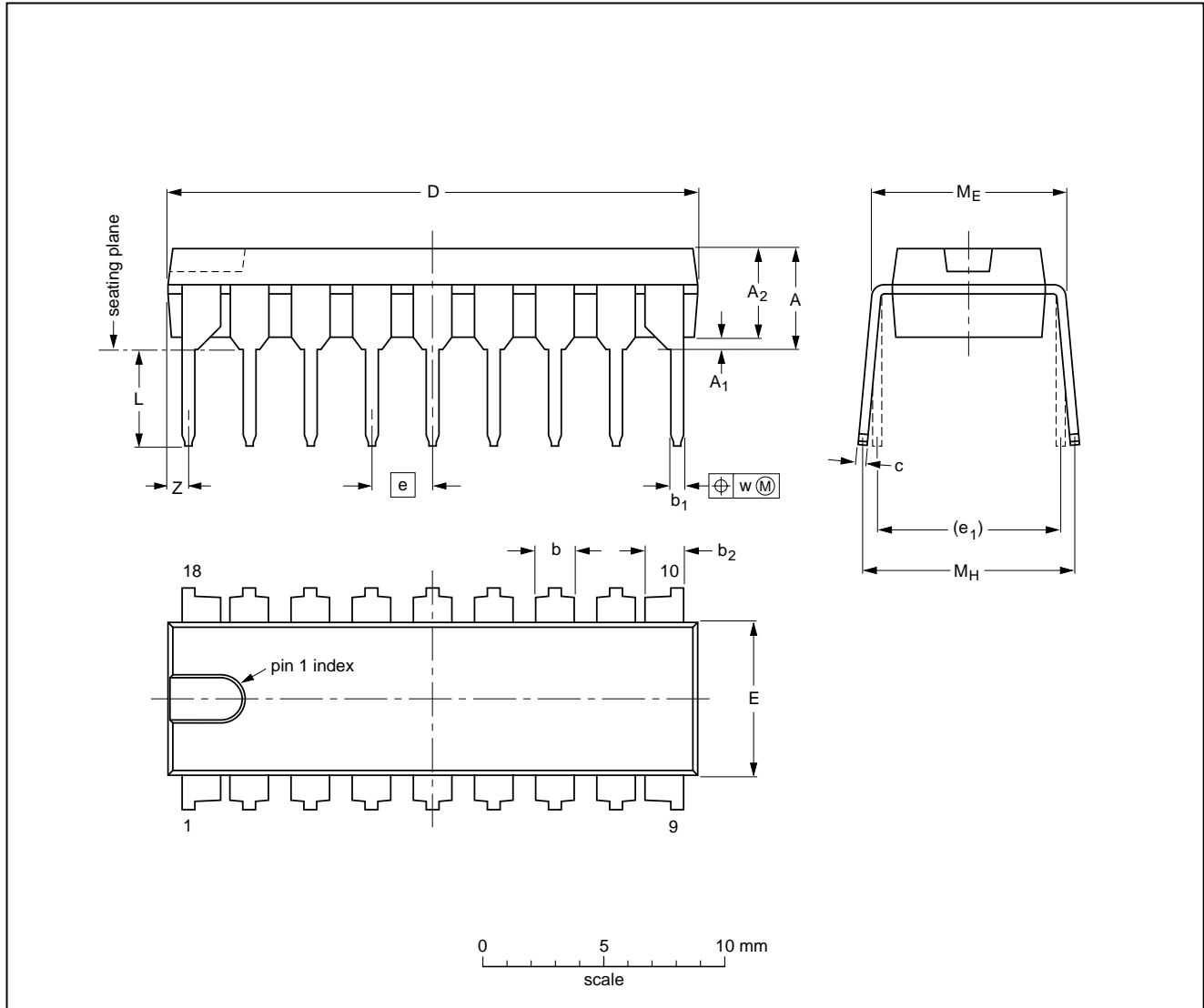

DIMENSIONS (inch dimensions are derived from the original mm dimensions)

UNIT	A max.	A <sub>1</sub> min.	A <sub>2</sub> max.	b	b <sub>1</sub>	b <sub>2</sub>	c	D <sup>(1)</sup>	E <sup>(1)</sup>	e	e <sub>1</sub>	L	M <sub>E</sub>	M <sub>H</sub>	w	Z <sup>(1)</sup> max.
mm	4.7	0.51	3.7	1.40 1.14	0.53 0.38	1.40 1.14	0.32 0.23	21.8 21.4	6.48 6.20	2.54	7.62	3.9 3.4	8.25 7.80	9.5 8.3	0.254	0.85
inches	0.19	0.020	0.15	0.055 0.044	0.021 0.015	0.055 0.044	0.013 0.009	0.86 0.84	0.26 0.24	0.10	0.30	0.15 0.13	0.32 0.31	0.37 0.33	0.01	0.033

Note

1. Plastic or metal protrusions of 0.25 mm maximum per side are not included.

OUTLINE VERSION	REFERENCES				EUROPEAN PROJECTION	ISSUE DATE
	IEC	JEDEC	EIAJ			
SOT102-1						93-10-14 95-01-23

## Switch for CTV receivers

## TDA8440

### SOLDERING

#### Introduction

There is no soldering method that is ideal for all IC packages. Wave soldering is often preferred when through-hole and surface mounted components are mixed on one printed-circuit board. However, wave soldering is not always suitable for surface mounted ICs, or for printed-circuits with high population densities. In these situations reflow soldering is often used.

This text gives a very brief insight to a complex technology. A more in-depth account of soldering ICs can be found in our "IC Package Databook" (order code 9398 652 90011).

#### Soldering by dipping or by wave

The maximum permissible temperature of the solder is 260 °C; solder at this temperature must not be in contact

with the joint for more than 5 seconds. The total contact time of successive solder waves must not exceed 5 seconds.

The device may be mounted up to the seating plane, but the temperature of the plastic body must not exceed the specified maximum storage temperature ( $T_{stg\ max}$ ). If the printed-circuit board has been pre-heated, forced cooling may be necessary immediately after soldering to keep the temperature within the permissible limit.

#### Repairing soldered joints

Apply a low voltage soldering iron (less than 24 V) to the lead(s) of the package, below the seating plane or not more than 2 mm above it. If the temperature of the soldering iron bit is less than 300 °C it may remain in contact for up to 10 seconds. If the bit temperature is between 300 and 400 °C, contact may be up to 5 seconds.

### DEFINITIONS

Data sheet status	
Objective specification	This data sheet contains target or goal specifications for product development.
Preliminary specification	This data sheet contains preliminary data; supplementary data may be published later.
Product specification	This data sheet contains final product specifications.
Limiting values	
Limiting values given are in accordance with the Absolute Maximum Rating System (IEC 134). Stress above one or more of the limiting values may cause permanent damage to the device. These are stress ratings only and operation of the device at these or at any other conditions above those given in the Characteristics sections of the specification is not implied. Exposure to limiting values for extended periods may affect device reliability.	
Application information	
Where application information is given, it is advisory and does not form part of the specification.	

### LIFE SUPPORT APPLICATIONS

These products are not designed for use in life support appliances, devices, or systems where malfunction of these products can reasonably be expected to result in personal injury. Philips customers using or selling these products for use in such applications do so at their own risk and agree to fully indemnify Philips for any damages resulting from such improper use or sale.

### PURCHASE OF PHILIPS I<sup>2</sup>C COMPONENTS



Purchase of Philips I<sup>2</sup>C components conveys a license under the Philips' I<sup>2</sup>C patent to use the components in the I<sup>2</sup>C system provided the system conforms to the I<sup>2</sup>C specification defined by Philips. This specification can be ordered using the code 9398 393 40011.