

Comparing Digital Potentiometers to Mechanical Potentiometers

Author: Bonnie C. Baker,
Microchip Technology Inc.

INTRODUCTION

Resistor potentiometers can be found in electronic circuits across a wide spectrum of applications. Most typically, they function in a voltage divider configuration in order to execute various types of tasks, such as offset or gain adjust. The two types of potentiometers compared in this application note are the mechanical potentiometer (also called a trimmer potentiometer) and the digital potentiometer. The physical descriptions and circuit models of these two devices are shown in Figure 1.

Basics of Mechanical Potentiometers

The first type of potentiometer on the market was mechanical in nature. This type of potentiometer is still available and adjustments of the wiper are implemented by twisting a knob, moving a slider, or using a screw driver. Although this method seems awkward, given the advent of the digital potentiometer, mechanical potentiometers still find their way into various electronic circuits.

Earlier mechanical potentiometers were built by wrapping a resistive wire around a cylinder. With this construction, the wiper moves from one winding to the next. As the wiper is moved across the element, there are discrete steps in resistance. Following this style of fabrication, the mechanical potentiometer was built using a resistive thick film that was screened onto a ceramic substrate. With this construction, the change in resistance across the element is continuous.

There are a variety of resistive materials that are used by mechanical potentiometer manufacturers. They include molded conductive plastic, conductive plastic film, screened conductive plastic, and cermet. Each resistive material has its own set of performance characteristics. In this application note the digital potentiometer will only be compared to the more popular cermet potentiometer. Cermet is a thick film resistive material that is a mixture of fine particles of ceramic or glass and precision metals such as silver, platinum, rhodium, or gold. The wiper of the mechanical potentiometer slides along the distance on the resistive material providing an analog resistive output that has an infinite number of positions across the span of the element.

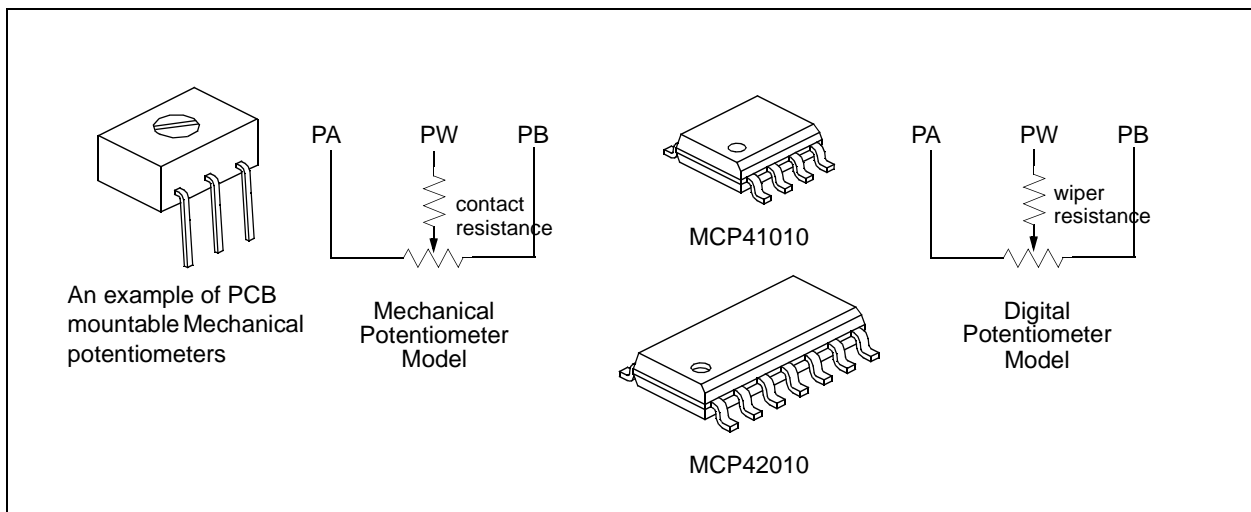

Figure 1: The mechanical potentiometer is constructed so that the user can easily adjust the position of the wiper (PW) by hand or with a screw driver. The digital potentiometer is manufactured so that the position of the wiper is adjusted by means of a serial digital code. The circuit representation of the digital potentiometer and the mechanical potentiometer is fundamentally the same.

The metal contacts of the mechanical potentiometer can affect the performance and reliability of the device. Higher cost potentiometers use multi-fingers made from precious metals in order to promote longer life as well as improve electrical performance in all environments. These higher quality potentiometers are not included in the discussions in this application note.

Basics of Digital Potentiometers

Digital potentiometers (Figure 2) were introduced in the market after the mechanical potentiometer. The digital potentiometer is fabricated using the same silicon technology used in active analog and digital integrated circuits use. This device comprises a combination of segmented resistive elements and on-chip switches. The resistive elements are manufactured using standard p-type silicon diffusions. Each resistive element can be switched from one side to the other side of the wiper using a serial digital command.

The digital potentiometer exhibits the same fundamental operation as the mechanical potentiometer with one primary exception. The wiper position is digitally programmed with a microcontroller. This style of adjustment allows the designer to adjust circuit performance dynamically using a digital controller. The additional programmability provides a solution where human intervention is not required. With this “hands-off” programmability, the digital potentiometer offers significant flexibility for a variety of applications.

Because this system is digital, the number of wiper positions is no longer infinite. For example, Microchip’s MCP41XXX and MCP42XXX family of potentiometers are all 8-bit and have 256 unique linear positions along the total resistive element.

Beyond the basic differences in fabrication and functionality of these two styles of potentiometers, there are several specifications that describe the difference and similarities of these devices further.

Changes of Resistive Element Due to Environmental Cycling

Environmental changes such as temperature or humidity can have an adverse effect on an application circuit where a mechanical potentiometer is used. Since mechanical potentiometers have moving parts, they can be more sensitive to these types of environmental changes. The reaction of a typical mechanical potentiometer to these types of environmental changes is shown in Table 1.

Environmental Event (per Mil-R-94 standard)	Maximum Allowable Resistance Change of Mechanical Potentiometer
Temperature Cycling	±1% to ±10%
High Temperature Exposure	±2% @ 125 °C for 250 hours
Humidity excursions	±15%

Table 1: The environment can have an adverse effect on the reliability of the mechanical potentiometer. The specifications in this table were taken from data sheets of higher quality mechanical potentiometers.

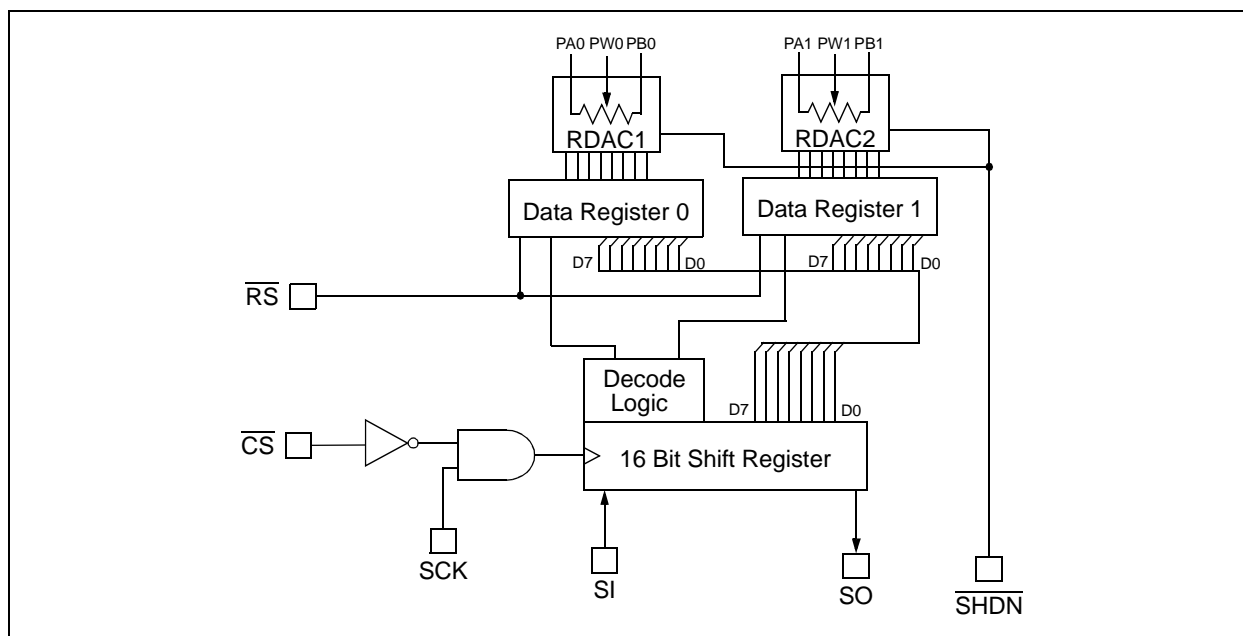

Figure 2: This is an example of a dual digital potentiometer. The digital potentiometer is programmed via a serial interface.

Since digital potentiometers are manufactured using a standard CMOS process with no moving parts, the reaction to these environmental changes are significantly reduced.

Vibration or Shock

Vibration or shock can also have an effect on an application circuit by causing physical movement. All devices that are soldered on a PCB can have failures due to vibration or shock, but the moving mechanism of mechanical potentiometers may also move.

A typical specification for a mechanical potentiometer would be a $\pm 2\%$ change due to vibrations that span from 10Hz to 2kHz. Another way of describing the effects of movement on the mechanical potentiometer is force. Typically 20Gs of force on a higher quality mechanical potentiometer would cause a maximum of $\pm 1\%$ resistive change.

Since there are no moving parts in digital potentiometers, the element will remain unchanged with vibration or shock tests unless discontinuities occur in the PCB construction.

Mean Time to Failure Life

One type of failure that is quantified with mechanical potentiometers is the mean time to failure life of the wiper adjustment capability. A typical specification for this type of failure would be that the device could survive several hundred cycles without discontinuity. A cycle is defined as changing the wiper position across full scale once. With thin film mechanical potentiometers, such as those constructed of cermet, a failure resulting from repeated cycles manifests itself as reduced performance.

Since the wiper of the digital potentiometer is controlled by electrical switches, the resistive elements are not effected by repeated cycles. Consequently, the digital potentiometer is a more robust solution.

Nominal Total Resistance

The nominal total resistance of a potentiometer is the typical specified resistance (in ohms) that can be measured between terminal PA and terminal PB per Figure 1. Typical values for digital potentiometers are 10k Ω , 50k Ω , and 100k Ω . Nominal resistance values below 10k Ω become difficult to implement in silicon because of the switch resistances. Values higher than 100k Ω are possible but require more silicon, which increases the cost of the device.

The range of the selection of the mechanical potentiometer is considerably wider with values such as 10 Ω , 20 Ω , 50 Ω , 100 Ω , 200 Ω , 500 Ω , 1k Ω , 2k Ω , 5k Ω , 10k Ω , 20k Ω , 25k Ω , 50k Ω , 100k Ω , 250k Ω , 500k Ω , 1M Ω , and 2M Ω .

The mechanical potentiometer might be considered attractive because of the wide range of nominal resistance offerings. However, the most common nominal resistance ranges used in adjustment type circuits are

1k Ω through 1M Ω . This range of potentiometers are available in both the digital and mechanical potentiometers.

Total Resistance Tolerance

The total resistance tolerance of the element between terminal PA and terminal PB varies from part to part. With digital potentiometers that variance is dependent on processing variance of the resistive material and switches. Typical digital potentiometer total resistance tolerances are between $\pm 20\%$ to $\pm 30\%$. On the other hand, variance of the cermet material in mechanical potentiometers range from ± 10 to $\pm 25\%$.

Although there seems to be a degree of difference between the digital potentiometer and mechanical potentiometer, the variability of the nominal resistance of both devices is considerably larger than standard 1% discrete resistors. In some applications, these tolerance values can cause errors that are too large. For additional design help, refer to the numerous circuit ideas in Microchip's application note, AN-691, "Optimizing Digital Potentiometer Circuits to Reduce Absolute and Temperature Variations".

Temperature Coefficient

Mechanical potentiometers and digital potentiometers drift with temperature. The range of typical drift specifications for the total resistance of the mechanical potentiometer is from $\pm 100\text{ppm}/^\circ\text{C}$ to $\pm 300\text{ppm}/^\circ\text{C}$. Typical drift versus temperature specification for the digital potentiometer is around $\pm 800\text{ppm}/^\circ\text{C}$. With both types of potentiometers, the temperature coefficient difference between the A element (resistance between PA and PW minus the wiper resistance) and B element (resistance between PB and PW minus the wiper resistance) is very low.

The magnitude of these specifications may or may not affect the performance of the circuit. If it is found that they do, numerous circuit ideas are available in Microchip's application note, AN-691, "Optimizing Digital Potentiometer Circuits to Reduce Absolute and Temperature Variations".

Power Rating

Mechanical potentiometers can sustain more power dissipation than the digital potentiometers. It is not unusual to have a mechanical potentiometer that is capable of dissipating 0.5W @ 70 $^\circ\text{C}$ (usually specified for 1000 hours). However, the wiper of the mechanical potentiometer usually can only conduct up to 1mA of current. This becomes a limitation if the potentiometer is configured so that the wiper is directly connected to terminal A or terminal B.

The digital potentiometer is capable of conducting power up to 0.0055W @ 70 $^\circ\text{C}$. It also has a 1mA maximum wiper current restriction.

Temperature Range

Both the mechanical potentiometer and digital potentiometer are specified to be able to operate over industrial temperature range of -40°C to 85°C. Most typically, the mechanical potentiometer is specified to operate over the military range of -55°C to 125°C.

CONCLUSION

Mechanical potentiometers have advantages in terms of having a wide variety of values available and tighter specifications such as nominal resistance, tolerance, temperature coefficient, power rating and temperature range specifications. But in many applications the overriding factors are related to environmental and reliability issues. These characteristics are not necessarily specified by the mechanical potentiometer vendor.

Digital potentiometers go hand in hand with the drive towards digital system control. This type of potentiometer is considerably more robust than its predecessor, the mechanical potentiometer, in terms of environmental exposure issues and longevity with repeated use of the wiper. But beyond the reliability issues, the digital potentiometer offers hands-off programmability. This programmability also allows the user to repeatedly and reliably return to the same wiper position.

REFERENCES:

Baker, Bonnie C., *"Optimizing Digital Potentiometer Circuits to Reduce Absolute and Temperature Variations"*, AN-691, Microchip Technology Inc.

Todd, Carl David, *"The Potentiometer Handbook: Users' Guide to Cost-effective Applications"*, McGraw-Hill, 1975.

Baker, Bonnie C., *"Using a Digital Potentiometer to Optimize a Precision Single Supply Photo Detection Circuit"*, AN-692, Microchip Technology Inc.

Baker, Bonnie C., *"Using Digital Potentiometers to Design Low Pass Adjustable Filters"*, AN-737, Microchip Technology Inc.

NOTES:

AN219

NOTES:

NOTES:



WORLDWIDE SALES AND SERVICE

AMERICAS

Corporate Office

2355 West Chandler Blvd.
Chandler, AZ 85224-6199
Tel: 480-792-7200 Fax: 480-792-7277
Technical Support: 480-792-7627
Web Address: <http://www.microchip.com>

Rocky Mountain

2355 West Chandler Blvd.
Chandler, AZ 85224-6199
Tel: 480-692-7966 Fax: 480-792-7456

Atlanta

500 Sugar Mill Road, Suite 200B
Atlanta, GA 30350
Tel: 770-640-0034 Fax: 770-640-0307

Boston

2 Lan Drive, Suite 120
Westford, MA 01886
Tel: 978-692-3838 Fax: 978-692-3821

Chicago

333 Pierce Road, Suite 180
Itasca, IL 60143
Tel: 630-285-0071 Fax: 630-285-0075

Dallas

4570 Westgrove Drive, Suite 160
Addison, TX 75001
Tel: 972-818-7423 Fax: 972-818-2924

Dayton

Two Prestige Place, Suite 130
Miamisburg, OH 45342
Tel: 937-291-1654 Fax: 937-291-9175

Detroit

Tri-Atria Office Building
32255 Northwestern Highway, Suite 190
Farmington Hills, MI 48334
Tel: 248-538-2250 Fax: 248-538-2260

Los Angeles

18201 Von Karman, Suite 1090
Irvine, CA 92612
Tel: 949-263-1888 Fax: 949-263-1338

New York

150 Motor Parkway, Suite 202
Hauppauge, NY 11788
Tel: 631-273-5305 Fax: 631-273-5335

San Jose

Microchip Technology Inc.
2107 North First Street, Suite 590
San Jose, CA 95131
Tel: 408-436-7950 Fax: 408-436-7955

Toronto

6285 Northam Drive, Suite 108
Mississauga, Ontario L4V 1X5, Canada
Tel: 905-673-0699 Fax: 905-673-6509

ASIA/PACIFIC

China - Beijing

Microchip Technology Beijing Office
Unit 915
New China Hong Kong Manhattan Bldg.
No. 6 Chaoyangmen Beidajie
Beijing, 100027, No. China
Tel: 86-10-85282100 Fax: 86-10-85282104

China - Shanghai

Microchip Technology Shanghai Office
Room 701, Bldg. B
Far East International Plaza
No. 317 Xian Xia Road
Shanghai, 200051
Tel: 86-21-6275-5700 Fax: 86-21-6275-5060

Hong Kong

Microchip Asia Pacific
RM 2101, Tower 2, Metroplaza
223 Hing Fong Road
Kwai Fong, N.T., Hong Kong
Tel: 852-2401-1200 Fax: 852-2401-3431

India

Microchip Technology Inc.
India Liaison Office
Divyasree Chambers
1 Floor, Wing A (A3/A4)
No. 11, O'Shaughnessy Road
Bangalore, 560 025, India
Tel: 91-80-2290061 Fax: 91-80-2290062

Japan

Microchip Technology Intl. Inc.
Benex S-1 6F
3-18-20, Shinyokohama
Kohoku-Ku, Yokohama-shi
Kanagawa, 222-0033, Japan
Tel: 81-45-471-6166 Fax: 81-45-471-6122

Korea

Microchip Technology Korea
168-1, Youngbo Bldg. 3 Floor
Samsung-Dong, Kangnam-Ku
Seoul, Korea
Tel: 82-2-554-7200 Fax: 82-2-558-5934

ASIA/PACIFIC (continued)

Singapore

Microchip Technology Singapore Pte Ltd.
200 Middle Road
#07-02 Prime Centre
Singapore, 188980
Tel: 65-334-8870 Fax: 65-334-8850

Taiwan

Microchip Technology Taiwan
11F-3, No. 207
Tung Hua North Road
Taipei, 105, Taiwan
Tel: 886-2-2717-7175 Fax: 886-2-2545-0139

EUROPE

Denmark

Microchip Technology Denmark ApS
Regus Business Centre
Lautrup hoj 1-3
Ballerup DK-2750 Denmark
Tel: 45 4420 9895 Fax: 45 4420 9910

France

Arizona Microchip Technology SARL
Parc d'Activite du Moulin de Massy
43 Rue du Saule Trapu
Batiment A - 1er Etage
91300 Massy, France
Tel: 33-1-69-53-63-20 Fax: 33-1-69-30-90-79

Germany

Arizona Microchip Technology GmbH
Gustav-Heinemann Ring 125
D-81739 Munich, Germany
Tel: 49-89-627-144 0 Fax: 49-89-627-144-44

Italy

Arizona Microchip Technology SRL
Centro Direzionale Colleoni
Palazzo Taurus 1 V. Le Colleoni 1
20041 Agrate Brianza
Milan, Italy
Tel: 39-039-65791-1 Fax: 39-039-6899883

United Kingdom

Arizona Microchip Technology Ltd.
505 Eskdale Road
Winnersh Triangle
Wokingham
Berkshire, England RG41 5TU
Tel: 44 118 921 5869 Fax: 44-118 921-5820

10/01/00

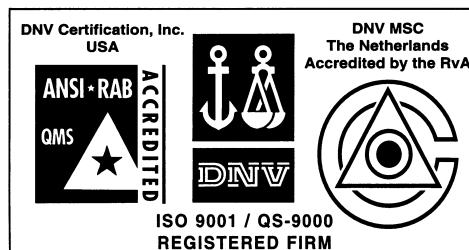

Microchip received QS-9000 quality system certification for its worldwide headquarters, design and wafer fabrication facilities in Chandler and Tempe, Arizona in July 1999. The Company's quality system processes and procedures are QS-9000 compliant for its PICmicro® 8-bit MCUs, KEELoc® code hopping devices, Serial EEPROMs and microperipheral products. In addition, Microchip's quality system for the design and manufacture of development systems is ISO 9001 certified.

All rights reserved. © 2000 Microchip Technology Incorporated. Printed in the USA. 11/00 Printed on recycled paper.

Information contained in this publication regarding device applications and the like is intended through suggestion only and may be superseded by updates. It is your responsibility to ensure that your application meets with your specifications. No representation or warranty is given and no liability is assumed by Microchip Technology Incorporated with respect to the accuracy or use of such information, or infringement of patents or other intellectual property rights arising from such use or otherwise. Use of Microchip's products as critical components in life support systems is not authorized except with express written approval by Microchip. No licenses are conveyed, implicitly or otherwise, except as maybe explicitly expressed herein, under any intellectual property rights. The Microchip logo and name are registered trademarks of Microchip Technology Inc. in the U.S.A. and other countries. All rights reserved. All other trademarks mentioned herein are the property of their respective companies.