

PROTECTION CIRCUIT FOR OCL POWER AMPLIFIER
AND SPEAKER

- . Over current detecting circuit
Operation at the time of over load, such as a speaker terminal short.
- . DC voltage detecting circuit
Operation at the time when positive or negative DC voltage ($\pm 1.1V$ of detection level) has generated at output terminals.
- . Muting circuit
Transient noise protection when power is ON-OFF.
- . Relay driver circuit (Drive current of 130mA at Max.)
- . Operation by dual power supply.

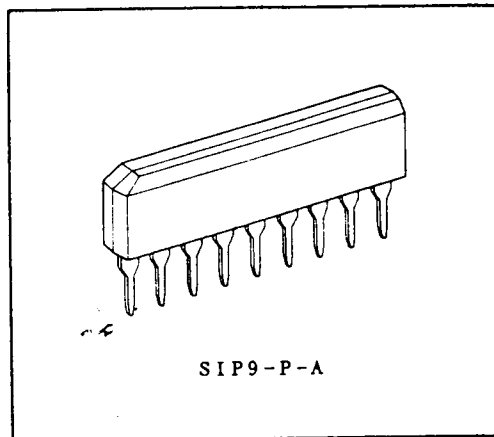

SIP9-P-A

Weight: 0.9g(Typ.)

MAXIMUM RATINGS ($T_a=25^{\circ}C$)

CHARACTERISTIC	SYMBOL	RATING	UNIT
Supply Voltage	V_{CC}	60	V
Relay Driver Output Current	I_{OUT}	130	mA
Power Dissipation	P_D	500	mW
Operating Temperature	T_{opr}	-20 ~ 75	$^{\circ}C$
Storage Temperature	T_{stg}	-55 ~ 150	$^{\circ}C$

ELECTRICAL CHARACTERISTICS ($V_{CC}=\pm 50V$, $T_a=25^{\circ}C$)

CHARACTERISTIC	SYMBOL	TEST CIR-CUIT	TEST CONDITION	MIN.	TYP.	MAX.	UNIT
Supply Current	$I_{CC ON}$	-	$V_1 IN=-5V$, $\pm V_{DC}=0V$, SW:OFF	-	54	-	mA
	$I_{CC OFF}$	-	$V_1 IN=0V$, $\pm V_{DC}=0V$, SW:OFF	1.5	2.4	4	
DC Detector Voltage	$+V_{DC}$	-	Note 1	0.9	1.1	1.3	V
	$-V_{DC}$	-	Note 1	-0.9	-1.1	-1.3	
Output Voltage	$V_{OUT(ON)}$	-	$V_1 IN=-5V$, $\pm V_{DC}=0V$, SW:OFF	-	1	2	V
	$V_{OUT(OFF)}$	-	$V_1 IN=0V$, $\pm V_{DC}=0V$, SW:OFF	-	50	-	
Muting Time at Power ON	M.T ($V_{CC ON}$)	-	Note 2	-	4	-	sec
Muting Time with Load Shorted	M.T	-	Note 3	-	3.5	-	sec
Pin 8 Entering Current	I_8	-	-	2	8	-	μA
Pin 9 Terminal Voltage	V_9	-	-	-	3.1	-	V
Pin 1 Terminal Voltage	V_1	-	-	-	0.75	-	V
Pin 5 Terminal Voltage	V_5	-	-	-	-0.75	-	V

MAXIMUM INTO OR OUT CURRENT

CHARACTERISTIC	SYMBOL	RATING	UNIT
Pin 1 Current	I_1	± 1.0	mA
Pin 2 Current	I_2	± 1.0	mA
Pin 3 Current	I_3	± 1.0	mA
Pin 5 Current	I_5	-6.0	mA
Pin 7 Current	I_7	1.0	mA
Pin 9 Current	I_9	5.0	mA

EQUIVALENT CIRCUIT

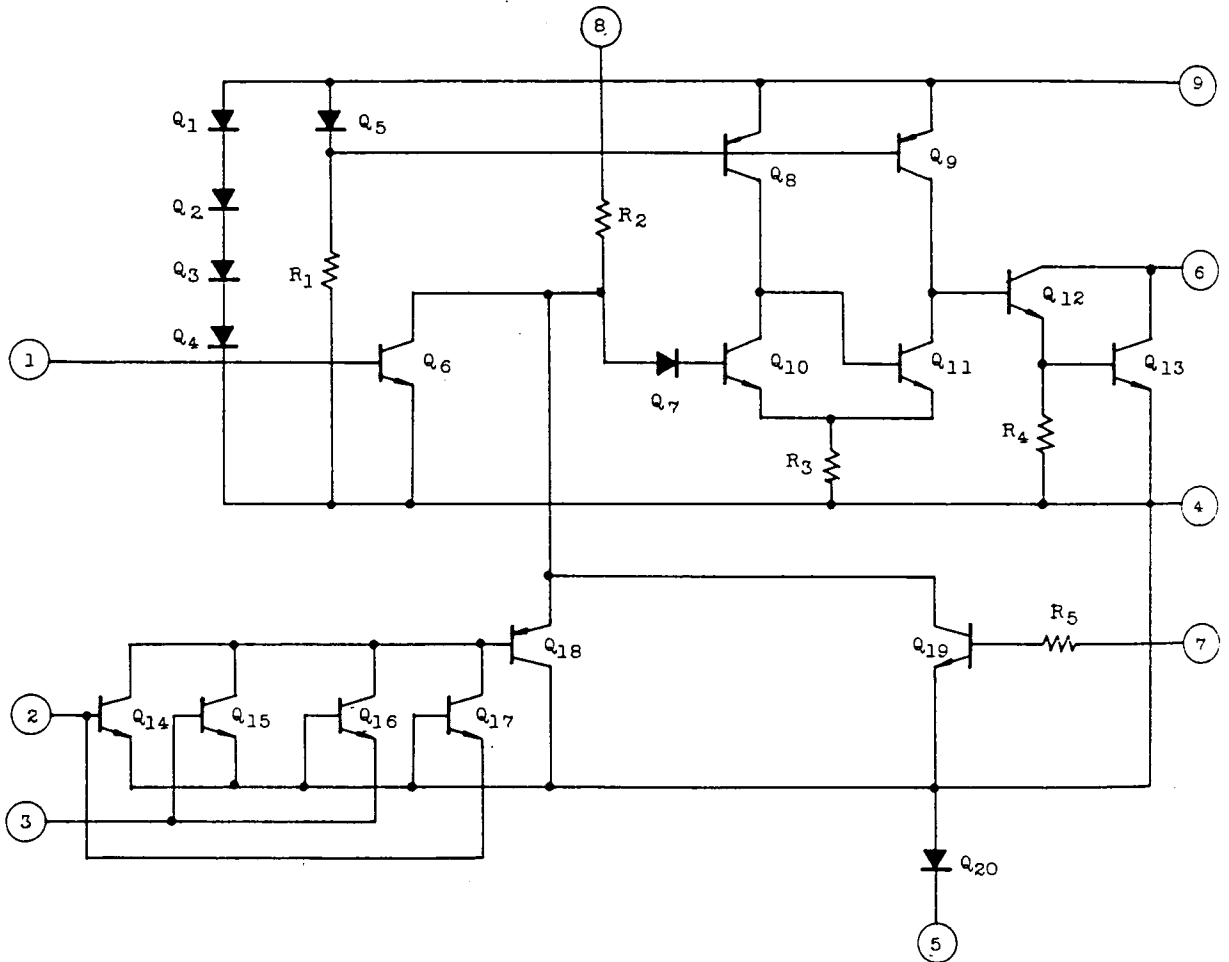

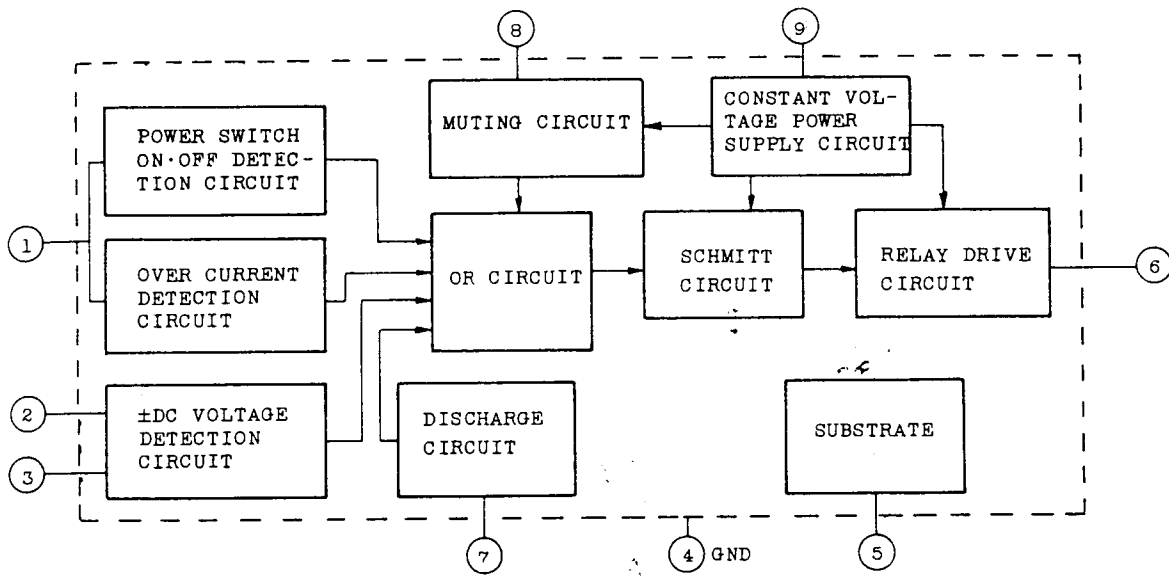

TEST CIRCUIT

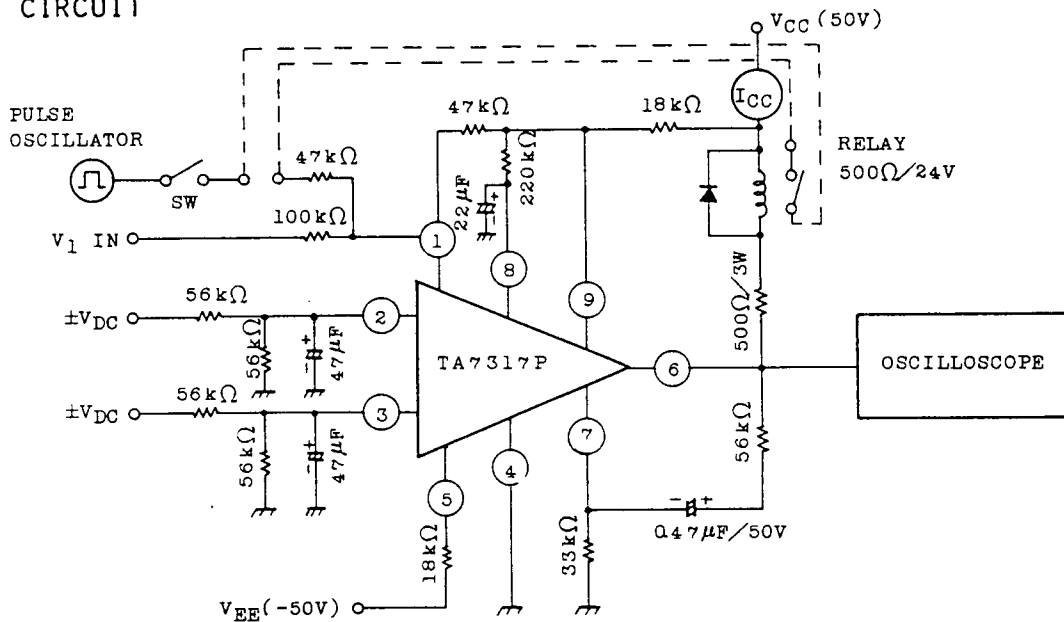

- (Note) 1. The value of $\pm V_{DC}$ at the time when the relay is turned from ON to OFF in the condition of $V_1 IN = -5V$ and SW-OFF.
2. The time required for the relay being turned from OFF to ON at $+V_{CC}$ ON in the condition of $V_1 IN = -5V$, $\pm V_{DC} = 0V$, and SW-OFF.
3. The duration of the relay being able to keep OFF when SW is turned ON in the condition of $V_1 IN = -5V$ and $\pm V_{DC} = 0V$. At that time input pulse is 3ms, -3V.

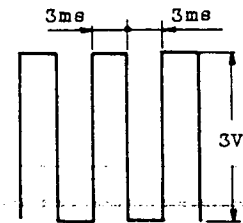

This datasheet has been downloaded from:

www.DatasheetCatalog.com

Datasheets for electronic components.