

추가 예정

BH Solution Confidential		
Title <Title>		
Size A3	Document Number <Doc>	Rev <Rev Code>
Date: Friday, August 27, 2004	Sheet 1	of 1

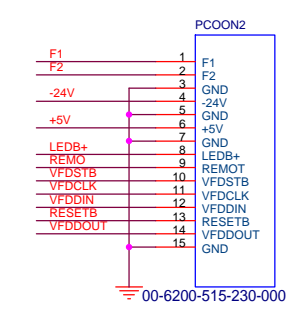

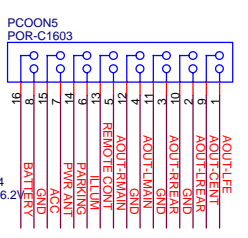
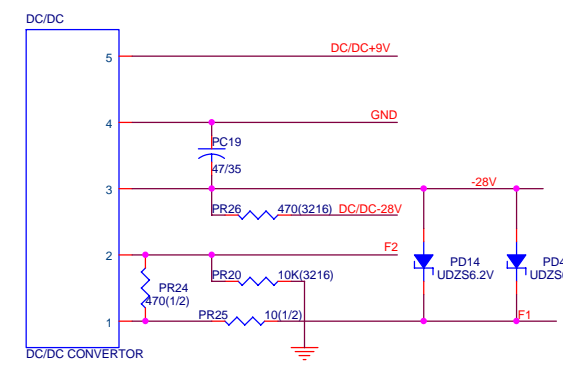
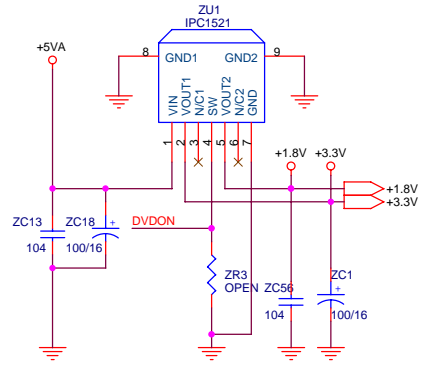
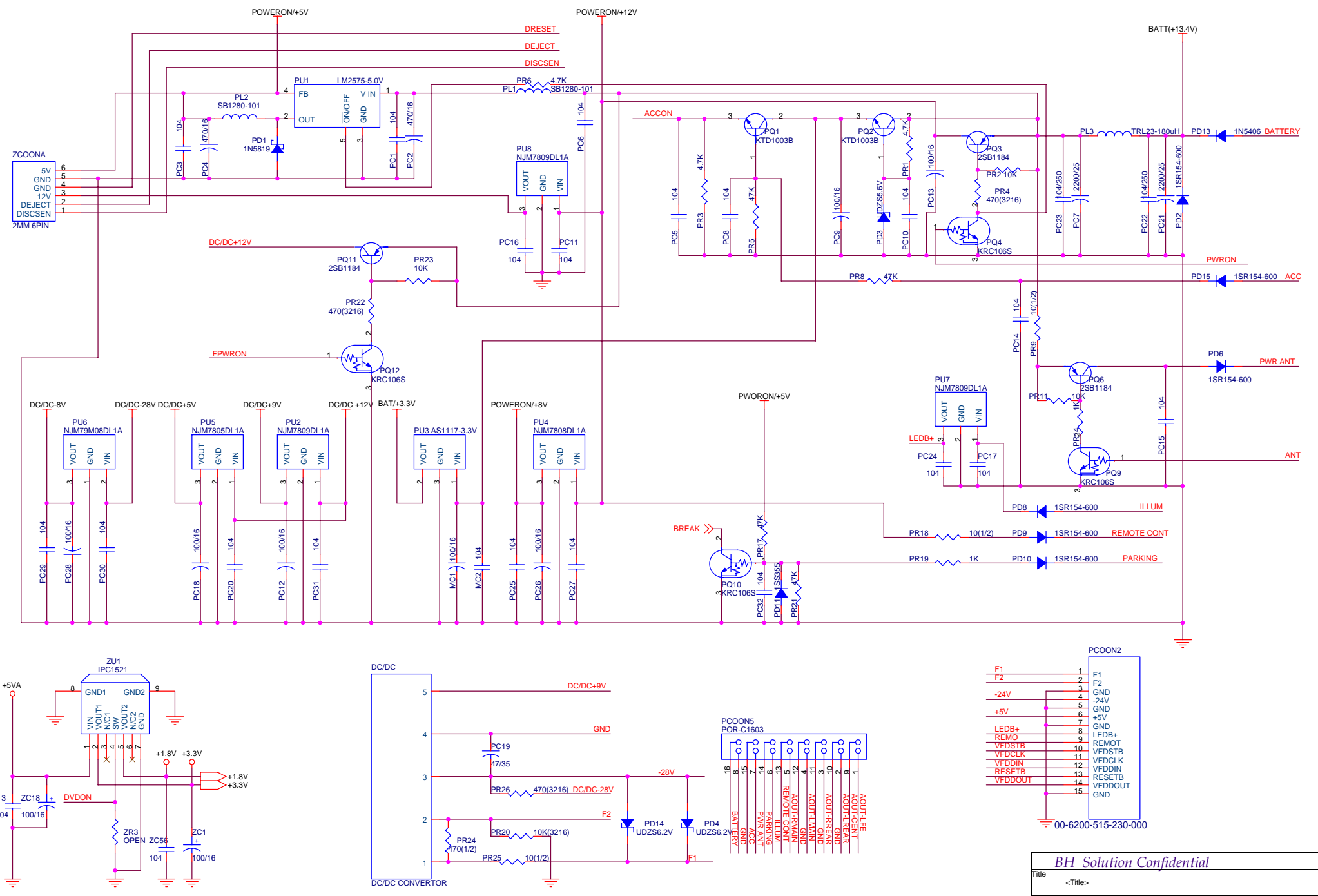
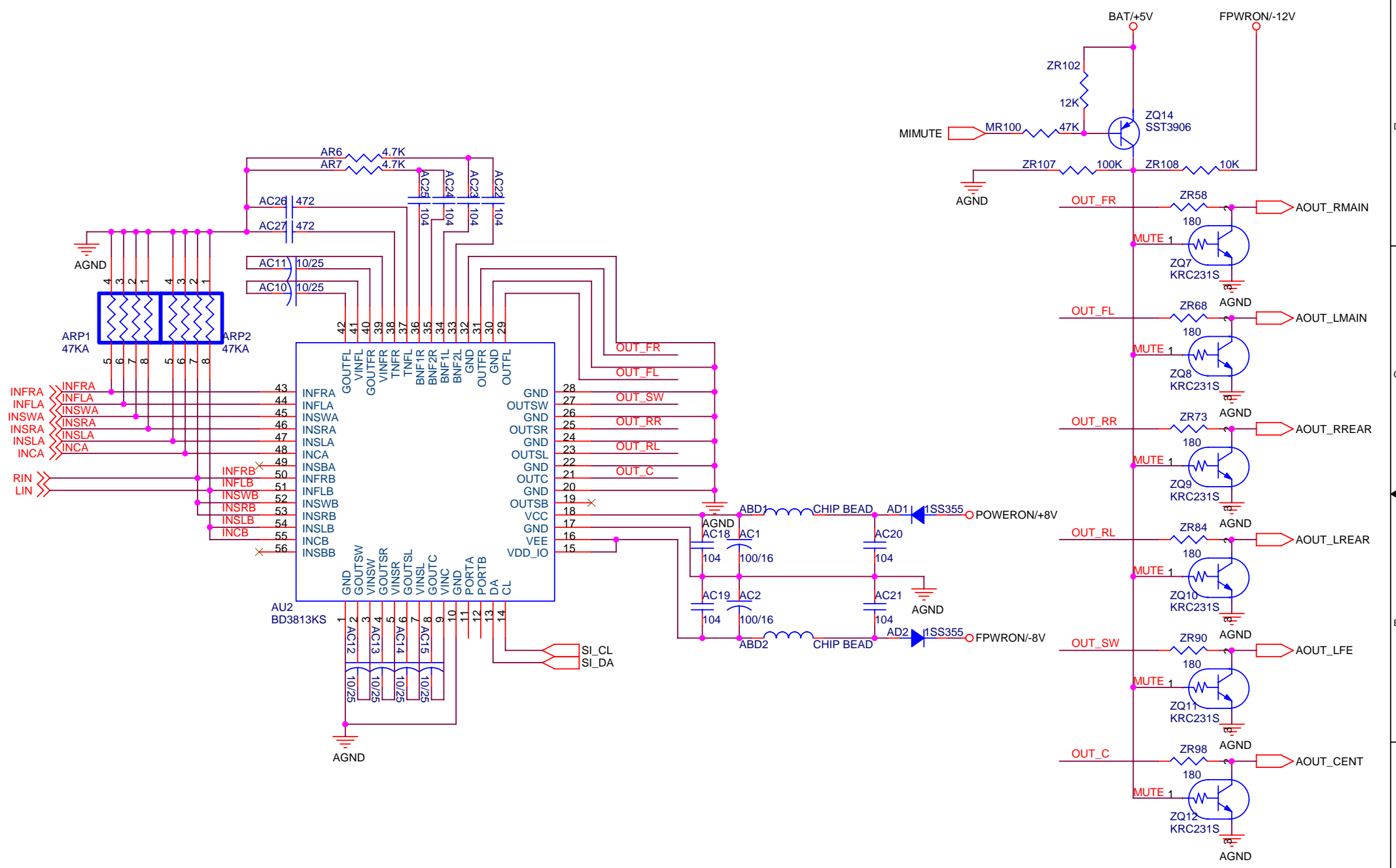

Title			<Title>
Size	Document Number	Rev	
A4	<Doc>	<RevCode>	
Date:	Friday, August 27, 2004	Sheet	1 of 1

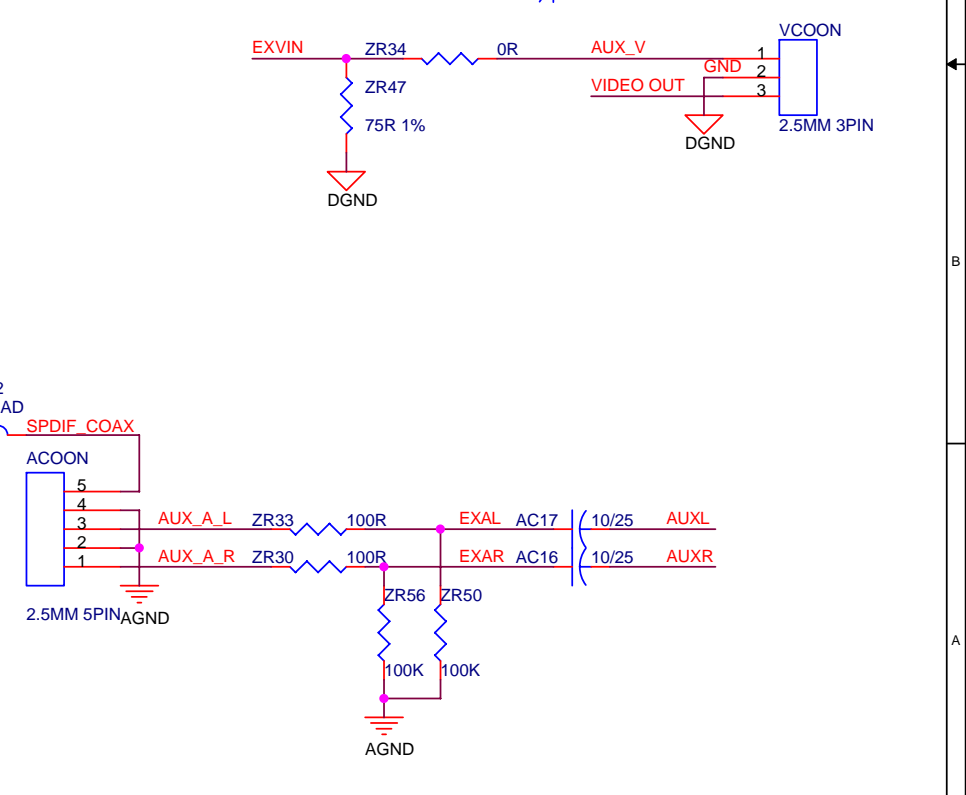
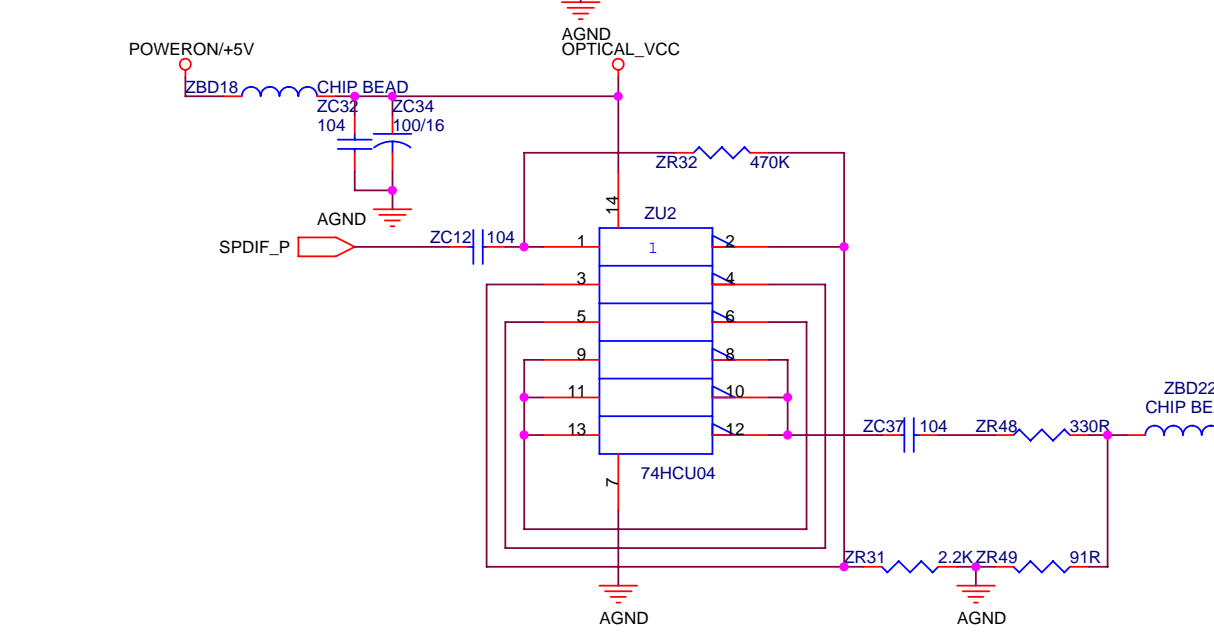
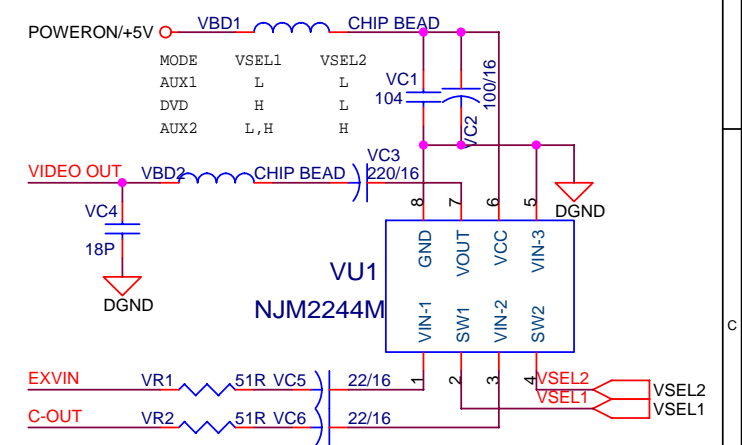
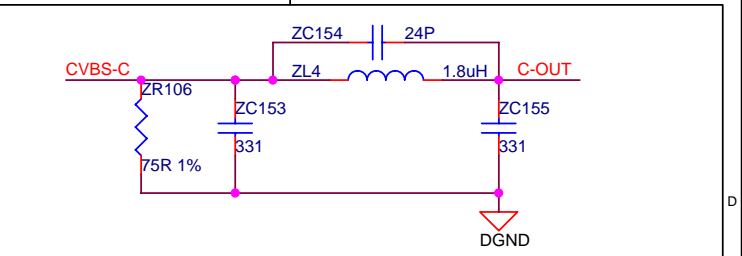
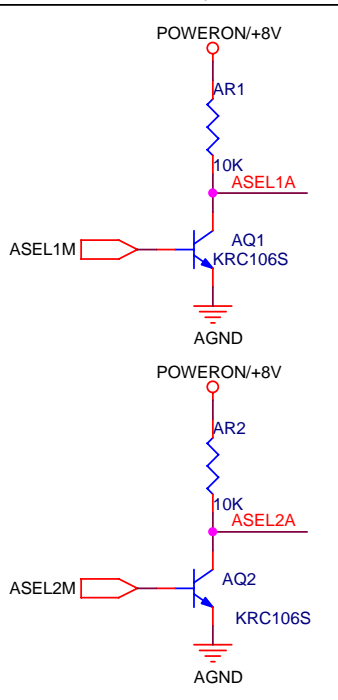
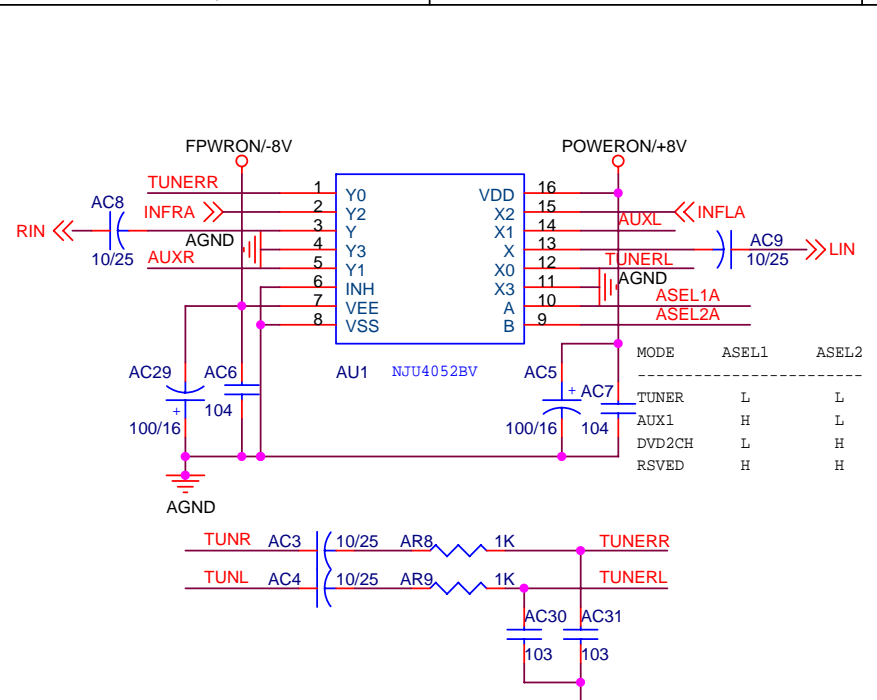

Title <Title>		
Size A4	Document Number <Doc>	Rev <RevCode>
Date: Friday, August 27, 2004	Sheet 1	of 1

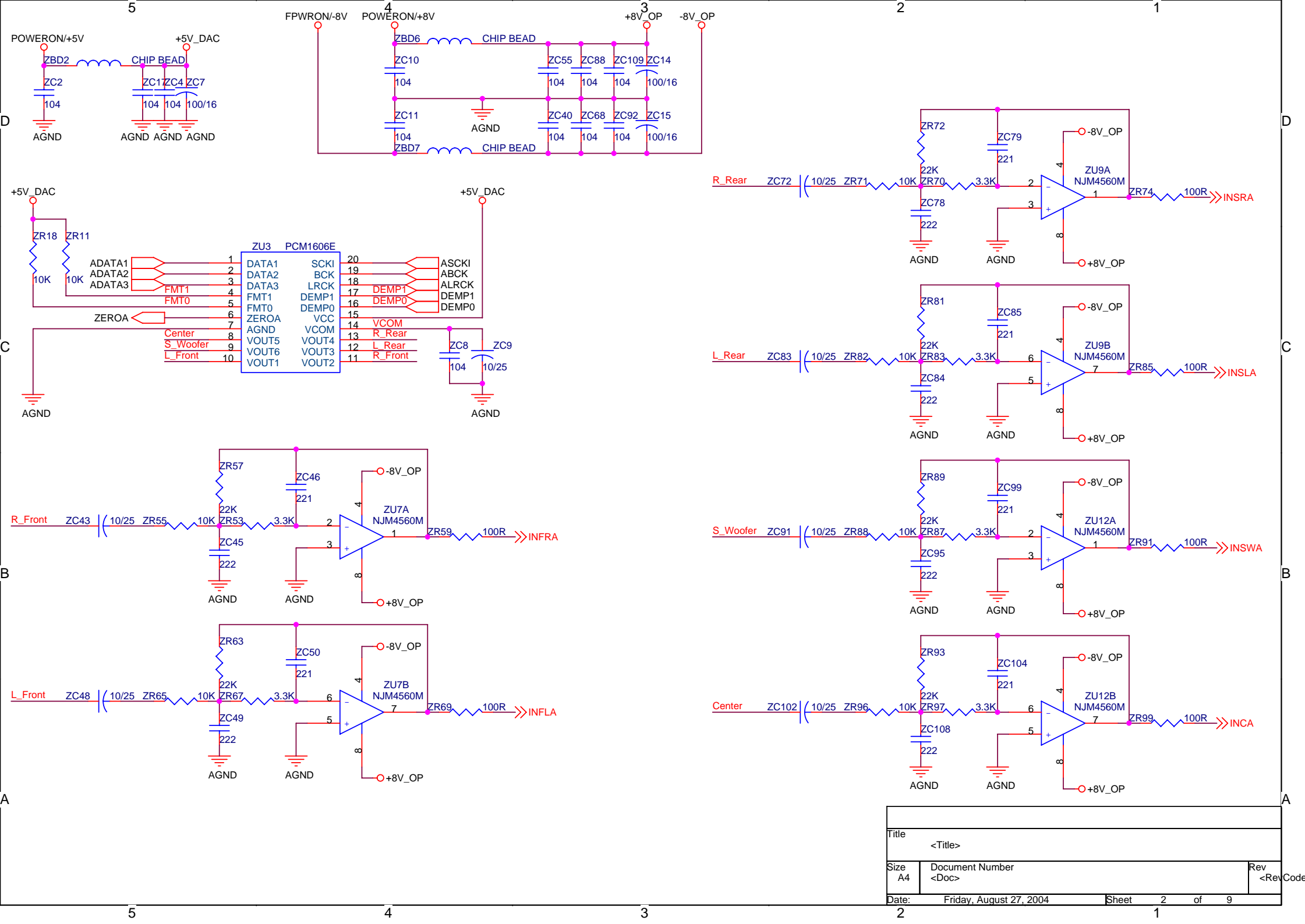

Title		
<Title>		
Size	Document Number	Rev
A4	<Doc>	<Rev Code>
Date:	Friday, August 27, 2004	Sheet 2 of 9

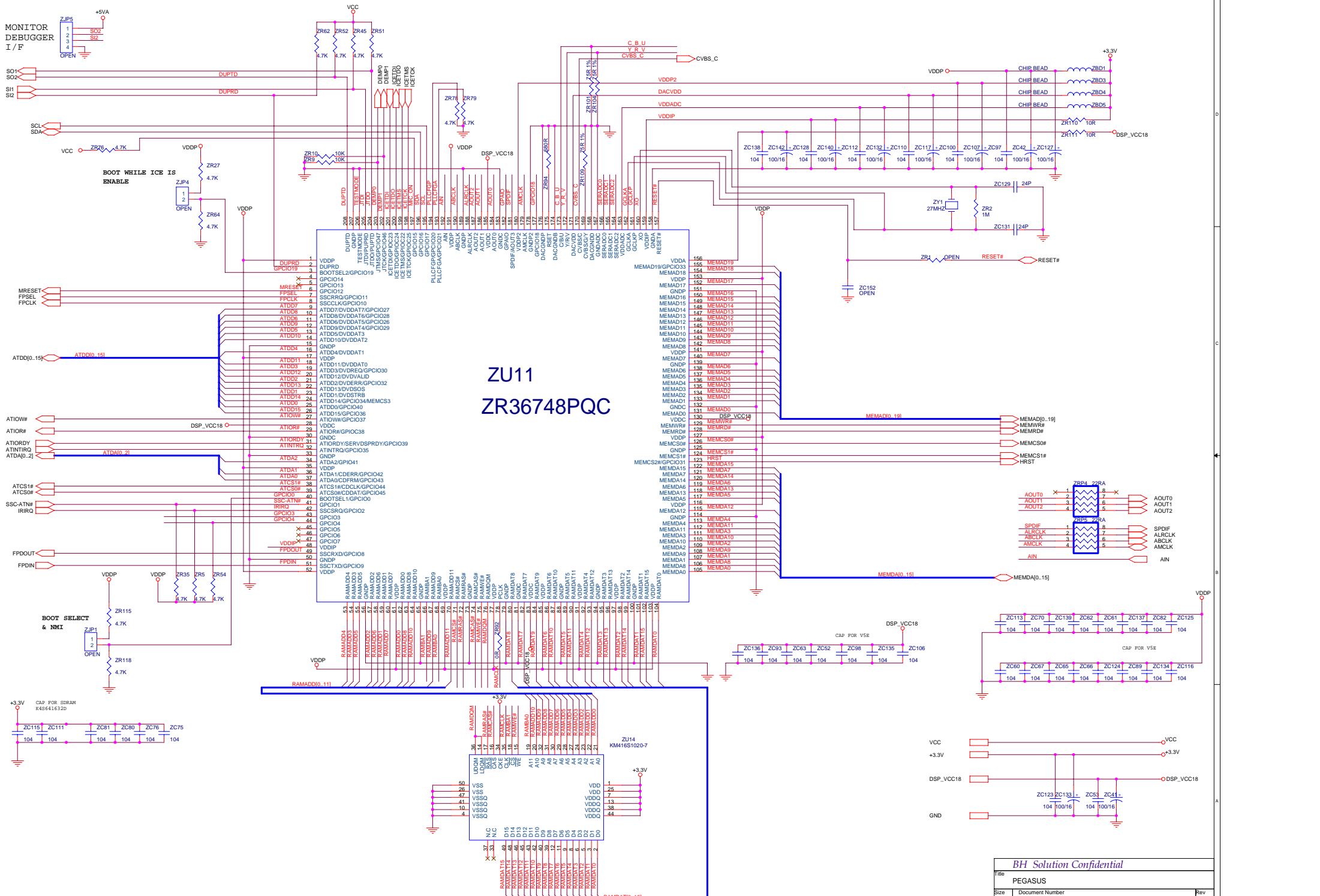

ZU11
ZR36748PQC

BH Solution Confidential

File	PEGASUS		Rev
Size	Document Number	VADDIS 5E	
Date	Friday, August 27, 2004	Sheet	4 of 7

