

# surround-sound subwoofer



## Part 3 (final)

After the detailed descriptions of the passive and active versions of the subwoofer in the previous two instalments, this third and final part deals with the complete construction. If the enclosure has already been built on the basis of Figure 5, only the printed-circuit boards need to be completed and built into the enclosure together with the drive unit.

The circuits shown in Figures 10 and 11 (Part 2), including the power supply for the cross-over filter in Figure 10, are intended to be built on the three printed-circuit boards shown in Figure 12. The three sections shown in the illustration are easily separated from one another by cutting or snapping off along the indicated lines. The power supply for the power amplifier will be described later in this instalment.

Building the filter board is straightforward, as one would expect with only three ICs, a handful of resistors, and some capacitors on a good-sized board. Make sure to fit the six wire bridges first. Rotary switch  $S_1$  may be mounted directly on to the board. Connect the two leds and switch  $S_2$  to the board via short lengths of stranded circuit wire (7/029).

The  $\pm 15$  V power supply for the filter does not take much more space than a box of matches. Since the filter draws only a modest cur-

rent, the mains transformer can be kept small (1.5 VA). The voltage regulators need not be cooled. Connect terminals '+', '0' and '-' to the corresponding terminals on the filter board via short lengths of stranded circuit wire. The mains voltage from the central mains entry is connected to the supply via terminal block  $K_1$ .

Populating the power amplifier

### Parts list:

#### FILTER

#### Resistors:

- $R_1, R_2 = 470 \text{ k}\Omega$
- $R_3, R_4 = 22 \text{ k}\Omega$
- $R_5 = 18 \text{ k}\Omega$
- $R_6, R_{11} = 15 \text{ k}\Omega$
- $R_7 = 820 \Omega$
- $R_8 = 1 \text{ k}\Omega$
- $R_9, R_{37} = 2.7 \text{ k}\Omega$
- $R_{10} = 8.2 \text{ k}\Omega$
- $R_{12}, R_{38} = 6.8 \text{ k}\Omega$
- $R_{13}, R_{17}, R_{21} = 6.65 \text{ k}\Omega, 1\%$
- $R_{14}, R_{18}, R_{22} = 5.36 \text{ k}\Omega, 1\%$
- $R_{15}, R_{19}, R_{23} = 4.42 \text{ k}\Omega$

board is straightforward, but a few aspects need to be watched. Firstly, transistors  $T_1$ – $T_3$  must be fitted at the track side of the board. These devices, together with  $T_4$ – $T_7$ , must be screwed to one and the same heat sink, in each and every case with the aid of insulating washers and bushes. To ensure maximum heat conduction, apply heat conducting paste to both sides of the washers for the IGBTs.

Secondly, as described in the previous instalment, the collectors of  $T_4$ – $T_7$  provide the output current in unison. To ensure that the transfer resistances are kept small and at the same time that the board does not become unduly warm, the connection between the collectors and the output relay is rather unusual. Immediately adjacent to the collector terminal is an additional hole on the board into which a solder pin is to be inserted (at the track side). The four pins must be interconnected by heavy-duty single-strand copper wire ( $\geq 1.5 \text{ mm}^2$ ) or

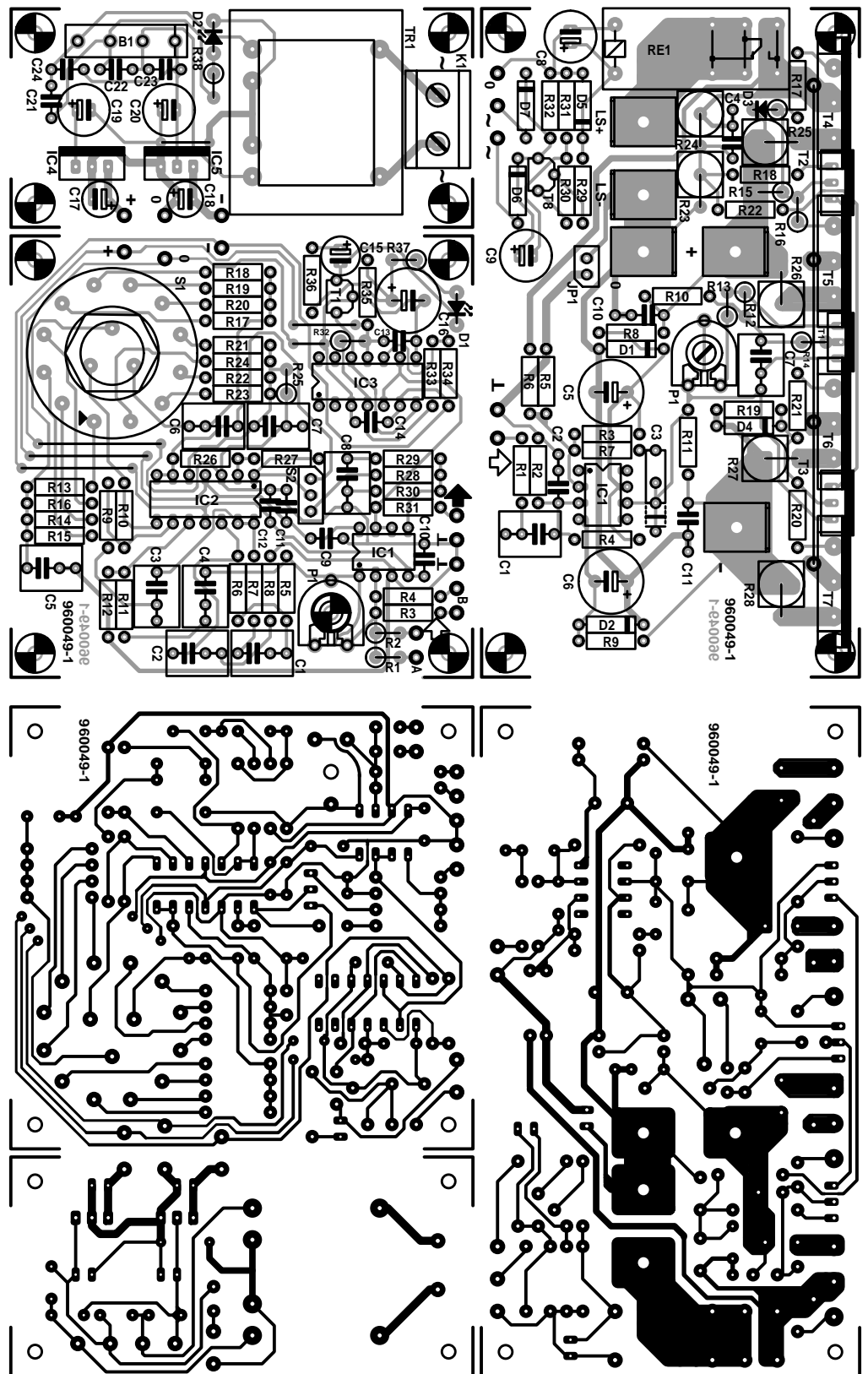

**Figure 12.** Because of the relative simplicity of the circuits, the amplifier and filter can be accommodated on one board; it is, however, advisable to separate the boards.

$R_{16}, R_{20}, R_{24} = 3.83 \text{ k}\Omega$   
 $R_{25} = 10 \text{ M}\Omega$   
 $R_{26}, R_{27} = 2.2 \text{ k}\Omega$   
 $R_{28} = 10 \text{ k}\Omega$   
 $R_{29} = 4.7 \text{ k}\Omega$   
 $R_{30} = 1 \text{ M}\Omega$   
 $R_{31}, R_{35} = 100 \Omega$   
 $R_{32}, R_{34} = 14.0 \text{ k}\Omega, 1\%$   
 $R_{33} = 2.00 \text{ k}\Omega, 1\%$   
 $R_{36} = 15 \Omega$   
 $P_1 = 47 \text{ k}\Omega$  preset potentiometer

#### Capacitors:

$C_1, C_3, C_6 = 2.2 \mu\text{F}$ , metallized polyester, pitch 5 mm  
 $C_2, C_9$ – $C_{14} = 100 \text{ nF}$

$C_4 = 470 \text{ nF}$ , metallized polyester, pitch 5 mm  
 $C_5 = 820 \text{ nF}$ , pitch  $\leq 7.5 \text{ mm}$   
 $C_7 = 120 \text{ nF}$   
 $C_8 = 680 \text{ nF}$   
 $C_{15} = 47 \mu\text{F}$ , 25 V, radial  
 $C_{16} = 470 \mu\text{F}$ , 25 V, radial  
 $C_{17}, C_{18} = 10 \mu\text{F}$ , 63 V, radial  
 $C_{19}, C_{20} = 220 \mu\text{F}$ , 25 V, radial  
 $C_{21}$ – $C_{24} = 47 \text{ nF}$ , ceramic

#### Semiconductors:

$D_1, D_2 = \text{LED}$ , low current  
 $B_1 = \text{B80C1500}$   
 $T_1 = \text{BC640}$

#### Integrated circuits:

$\text{IC}_1 = \text{NE5532}$   
 $\text{IC}_2 = \text{TL084}$   
 $\text{IC}_3 = \text{LM319}$   
 $\text{IC}_4 = 7815$   
 $\text{IC}_5 = 7915$

#### Miscellaneous:

$K_1 = 2$ -way terminal block, pitch 7.5 mm  
 $S_1 = \text{rotary switch}$ , 3-pole, 4-position, for board mounting  
 $S_2 = \text{single-pole change-over switch}$   
 $\text{Tr}_1 = \text{mains transformer}$ ,  $2 \times 15 \text{ V}$ , 1.5 VA  
 PCB Order no. 960049

## Parts list:

### AMPLIFIER

#### Resistors:

$R_1, R_5, R_{13} = 1\text{ k}\Omega$   
 $R_2, R_6 = 31.6\text{ k}\Omega, 1\%$   
 $R_3, R_4 = 8.2\text{ M}\Omega$  (see text)  
 $R_7 = 100\text{ k}\Omega$   
 $R_8, R_9 = 3.3\text{ k}\Omega, 0.5\text{ W}$   
 $R_{10}, R_{11} = 22\text{ k}\Omega$   
 $R_{12} = 3.3\text{ k}\Omega$   
 $R_{14} = 68\ \Omega$   
 $R_{15}, R_{19} = 220\ \Omega$   
 $R_{16}, R_{17}, R_{20}, R_{21} = 100\ \Omega$   
 $R_{18}, R_{22} = 22\ \Omega$   
 $R_{23} = 220\ \Omega, 5\text{ W}$   
 $R_{24} = 680\ \Omega, 5\text{ W}$   
 $R_{25}\text{--}R_{28} = 0.22\ \Omega, 5\text{ W}$   
 $R_{29} = 390\ \Omega$   
 $R_{30}, R_{31} = 47\text{ k}\Omega$   
 $R_{32} = 5.6\text{ k}\Omega$

$P_1 = 2.5\text{ k}\Omega$  preset potentiometer

#### Capacitors:

$C_1 = 270\text{ nF}$   
 $C_2 = 3.3\text{ nF}$   
 $C_3 = 22\ \mu\text{F}, 160\text{ V}, \text{polyester}$   
 $C_4 = 1\text{ nF}$   
 $C_5, C_6 = 220\ \mu\text{F}, 63\text{ V}, \text{radial}$   
 $C_7 = 2.2\ \mu\text{F}, \text{metallized polyester},$   
pitch 5 mm  
 $C_8 = 47\ \mu\text{F}, 50\text{ V}, \text{radial}$   
 $C_9 = 100\ \mu\text{F}, 40\text{ V}, \text{radial}$   
 $C_{10}, C_{11} = 100\text{ nF}$

#### Semiconductors:

$D_1, D_2 = 18\text{ V}, 1.3\text{ W}$  zener  
 $D_3, D_4 = 10\text{ V}, 1.3\text{ W}$  zener  
 $D_5\text{--}D_7 = 1\text{N}4004$   
 $T_1 = \text{BD}139$   
 $T_2 = \text{MJE}15030$  (Motorola)  
 $T_3 = \text{MJE}15031$  (Motorola)

$T_4, T_5 = \text{GT}20\text{D}201$  (Toshiba)  
 $T_6, T_7 = \text{GT}20\text{D}101$  (Toshiba)  
 $T_8 = \text{BC}640$

#### Integrated circuits:

$\text{IC}_1 = \text{AD}847\text{JN}$  (Analog Devices)

#### Miscellaneous:

$\text{JP}_1 = 2\text{-way}$  contact row and jumper, or wire bridge  
 $\text{Re}_1 = \text{relay}, 16\text{ A}, 24\text{ V}, 875\ \Omega$  (e.g., Siemens V23056-A0105-A101)  
 $\text{LS}_1 = \text{drive unit}$ , see text  
5 off flatcable (car-type) connectors with screw fitting  
1 off heat sink for  $T_1\text{--}T_7$ ,  $<0.55\text{ K W}^{-1}$ , e.g. SK47/100 SA (Fischer, available from Dau Ltd 01243 553 031)  
Insulating kits (washers; bushes) for  $T_1\text{--}T_7$   
PCB as for filter (see text)

13

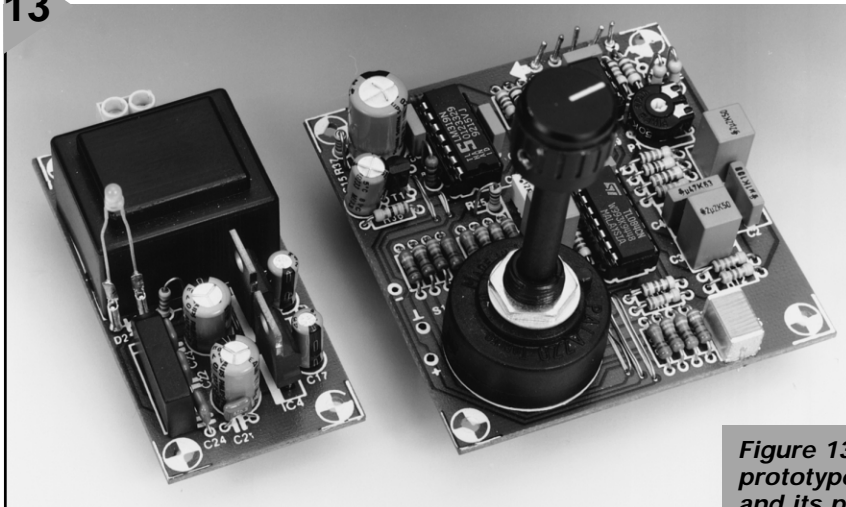

Figure 13. Completed prototype of the filter and its power supply.

clockwise.

Figures 13 and 14 show the completed prototype boards. Moreover, Figure 15 shows the underside of the power amplifier module, which gives a good view of  $T_1, T_2$  and  $T_3$ , the flatcable connectors for the supply lines and the loudspeaker connections, and the voltage rail that links the collectors of  $T_4\text{--}T_7$ . Note that this rail in the prototype consists of a folded strip of copper plate.

## AMPLIFIER POWER SUPPLY AND CALIBRATION

The power amplifier needs a symmetrical supply of  $\pm 49\text{ V}$ . The design of the supply may be simple, but it should ensure the provision of sufficient current. The design shown in Figure 16 is advised, since a transformer of  $2 \times 35\text{ V}$  at  $300\text{ VA}$ , a  $35\text{-A}$  bridge rectifier and four  $10\,000\ \mu\text{F}, 63\text{ V}$

a narrow strip of thin copper plate. It hardly needs emphasizing that thorough soldering of these parallel links is a prime requirement.

Furthermore, in order to ensure that the copper tracks for the supply lines and loudspeaker connections are not longer than strictly necessary, they are not taken to the edge of the board as is usual. Instead, the relevant solder pads are at the centre of the board and have been designed to allow flatcable (car-type) sockets to be screwed to them, preferably at the track side. Solder tags may be used, but these are nowhere near as robust as car connectors, which must, therefore, be preferred.

Three final remarks. (1) When populating the amplifier board, do not (yet) fit resistors  $R_3$  and  $R_4$ ; why

will be discussed shortly.

(2) Wire bridge  $\text{JP}_1$  provides the necessary link between the negative power supply line and earth; it should, however, not be fitted if such a link is already present in the power supply itself. (3) Turn preset potentiometer  $P_1$  fully anti-

14

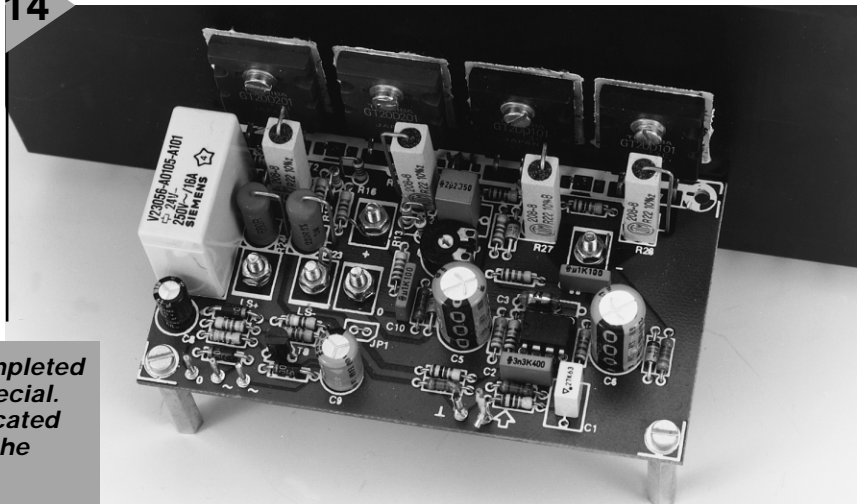

Figure 14. The top view of the completed amplifier board shows nothing special. The four output transistors are located together and well insulated from the heat sink.

electrolytic capacitors are fully up to the required task. The series resistors, in conjunction with the electrolytic capacitors, effectively decouple the supply lines to the amplifier.

As shown in Figure 16, the power-on delay circuit for the loudspeaker is supplied directly from the secondary windings of the mains transformer. If desired, a mains switch-on delay circuit, similar to that described on page 19 of our September 1995 issue, may be included at the primary side of the mains transformer.

Thoroughly check the amplifier board before commencing with the calibration. Provisionally connect the power supply and check that the potential across zener diodes  $D_1$  and  $D_2$  is about 18 V. If this is so, the setting of  $IC_1$  is correct and it may be assumed that the remainder of the amplifier is also all right.

Reverting to  $R_3$  and  $R_4$ : these resistors are intended to compensate the bias current of  $IC_1$  to ensure that there is no direct voltage at the amplifier output. Check this by measuring the voltage,  $U_C$ , at pin 3 of  $IC_1$  with a high-impedance voltmeter (multimeter) set to a millivolt range. The value of the resistors is calculated by

formula gives a value of the compensating resistors of  $8.2\text{ M}\Omega$  as specified in Figure 11. Note that the current levels may differ appreciably from one AD847 to another.

Set the quiescent current, which should be 100 mA through each of the output transistors. This is done by connecting a voltmeter or multimeter set to the 100 mV range across one of resistors  $R_{25}$ - $R_{28}$  and gently turning  $P_1$  clockwise until the meter reads 22 mV. Leave the amplifier on for about an hour and measure the voltage again; adjust  $P_1$  as required. Finally, check that the voltage drop across the other three resistors is the same.

### FINALLY ...

The construction of the wooden loudspeaker enclosure has already been described in Part 1. It is now time to select a metal case for the filter, amplifier and amplifier power supply. Note that it is important that the heat sink of the power amplifier remains on the outside so that it is in cooling ambient air.

It is best to mount the filter on spacers directly at the back of the front panel of the case so that ro-

## Different drive unit?

Although in the previous instalments reference has been made to a number of drive units, the preferred one remains the Monacor, since it gives excellent performance and offers very good cost-to-quality ratio. However, as mentioned in Part 2, even this otherwise excellent unit suffers from a deficiency. Although this deficiency is not serious, some readers may, none the less, be interested to know that we have found yet another drive unit that is suitable for the subwoofer. Finding alternative drive units is not easy since their parameters tend to differ to such an extent that changes to the dimensions of the enclosure and to the bass reflex tuning are often required. The alternative is the Type 30WD300 from Vifa. This is also a 300 mm woofer that fits

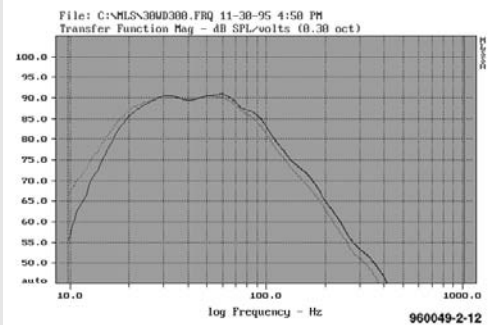

readily into the enclosure described in Part 1 and which can use the same filter as the other drive units. The characteristics in the illustration show that there are some differences between it and the Monacor unit, but that these are of not much consequence. The solid curve refers to the Vifa unit, and the dashed one to the Monacor unit.

The 30WD300 produces no spurious sounds and has an excellent overall performance. Unfortunately, like the Radio Shack and Parts Express units, it does not have a double voice coil, which makes it unsuitable for use in the passive version of the subwoofer. Used in the active version, it has a small benefit in that, because of its higher impedance, it requires a lower current from the power amplifier. This in turn means that the mains transformer may be a (less expensive) 225 VA type (and the fuse rating can be reduced to 1 A). On the other hand, the Vifa unit is dearer than the Monacor unit, so the choice is yours.

15

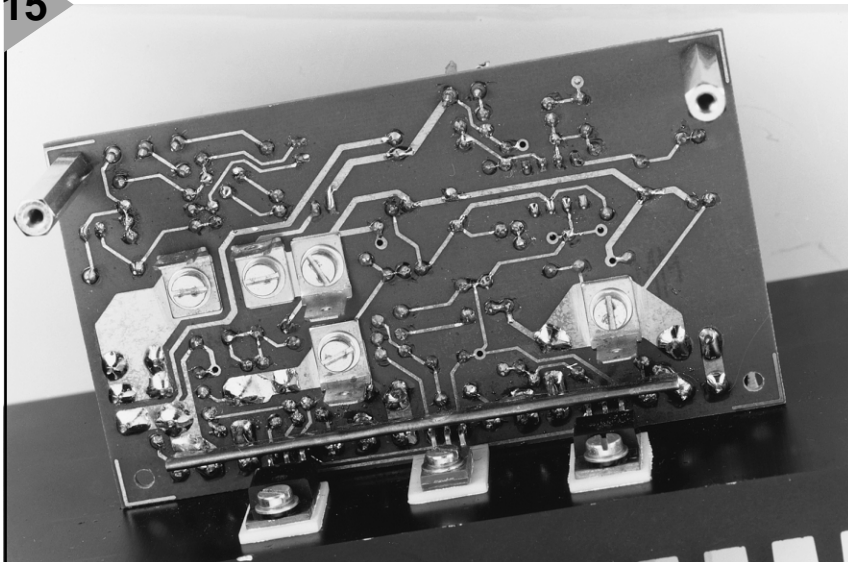

**Figure 15. The underside of the completed amplifier board shows  $T_1$ ,  $T_2$  and  $T_3$ , as well as the flatpack (car-type) connectors. The collectors of  $T_4$ - $T_7$  are interconnected with the aid of solder pins and a narrow strip of thin copper plate.**

$$R_3 = R_4 = (18/U_C) \times 31.6 \times 10^3. [\Omega]$$

In the prototype, the bias current through  $R_2$  is  $2.2\ \mu\text{A}$ , which results in a voltage at the non-inverting input of  $IC_1$  of 70 mV. Substituting this in the foregoing

tary switch  $S_1$  is readily accessible. Phase selector  $S_2$ , overdrive indicator  $D_1$  and on/off indicator  $D_2$  must also be mounted on the front panel. Drill a small hole in the relevant position to make the subwoofer's sound level

control  $P_1$  accessible for adjustment. It is, of course, possible to use a standard potentiometer for  $P_1$ , mount this on the front panel, and connect it to the board with two short lengths of stranded circuit wire.

Construction of the amplifier power supply should not present undue difficulties, but it should be robust. The transformer may be

screwed to the bottom of the case and the remainder on a small sheet of prototyping board. The connections between the secondary windings of the transformer, the bridge rectifier, the capacitors and resistors should be in heavy-duty, single-strand copper wire. The negative supply line shown bold in Figure 16 must be kept as short as possible. It is best to take the capacitor terminals and the centre tap of the transformer to a common point (star connection). The bridge rectifier must be mounted on a small heat sink or be screwed directly to the bottom of the case.

As far as the interconnections are concerned, those between the filter supply board and the filter board have already been discussed, as have the operating controls of the filter. Connect the high-level and line-level input pins to a couple of audio sockets via single screened audio cable. The output of the filter should be taken also via single screened audio cable to the input of the power amplifier (if the length of this cable is only a few centimetres, stranded circuit wire may be used instead of screened cable).

16

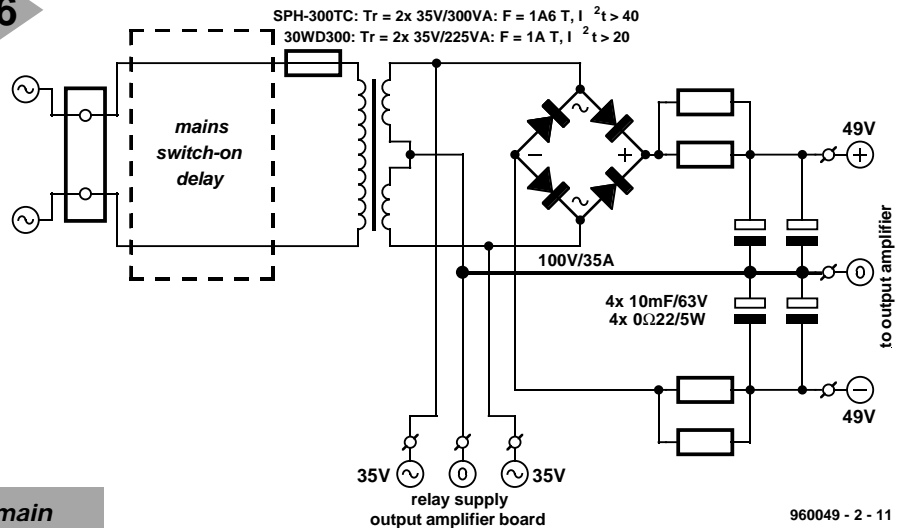

**Figure 16. The main requirement of the amplifier power supply is the ability to deliver sufficient current.**

speaker (with the two voice coils connected in parallel) via two lengths of the same cable to terminals '+LS' and '-LS' on the amplifier board.

Connect the primary of both mains transformers via heavy-duty, well-insulated cable to the mains entry at the rear of the case. Use a good-quality mains entry with integral fuse holder and on/off switch.

satellite or subwoofer systems. This is because such systems normally use small drive units that can just about handle 100–150 Hz, which means that the central bass unit must take over at that frequency. The present subwoofer is meant really as an addition to normal full-range loudspeaker systems, that is, compact to medium large loudspeaker enclosures that give a reasonable bass performance, but do not perform so well at the lower bass range. Position '70 Hz' will prove fine in use with most book-case-type loudspeakers, while with compact loudspeakers '60 Hz' will normally be the best value. Cross-over frequencies 40 Hz and 50 Hz are intended for combination with medium to large loudspeaker enclosures. The two lower frequencies, 30 Hz and 20 Hz, are usually best for use with electrostatic loudspeakers to give the 'thin' bass of these units rather more 'punch' at the lower end.

If your stereo loudspeakers are rather small, we can imagine that you will find the cross-over frequency chosen for the prototype rather low and would prefer to use the standard frequency for satellite/subwoofer systems. This is possible by altering the values of resistors  $R_{13}$ – $R_{24}$  as shown in Table 1 for frequencies 80 Hz, 90 Hz, 100 Hz and 100 Hz. These alterations do not affect the amplifier or the loudspeaker. [960049]

### Alteration of range of $S_1$

Cross-over frequency	Values of resistors (k $\Omega$ )			
	$R_{13}, R_{17}, R_{21}$	$R_{14}, R_{18}, R_{22}$	$R_{15}, R_{19}, R_{23}$	$R_{16}, R_{20}, R_{24}$
80 Hz	3.32			
90 Hz		2.94		
100 Hz			2.67	
110 Hz				2.43

The connections that need most attention are those between amplifier and amplifier power supply, and between amplifier and loudspeaker. The amplifier delivers an appreciable power output, so that the connections must be able to handle fairly large currents, while the transfer resistances must be kept to a minimum. It is, therefore, recommended to use cable with a cross-sectional diameter of  $\geq 2.5 \text{ mm}^2$ . Connect the amplifier power supply via three lengths of this cable, preferably terminated into car-type flat connectors to terminals '+', '0', and '-' on the amplifier board. Connect the loud-

### WHICH CROSS-OVER FREQUENCY?

The setting of  $P_1$  and  $S_1$  can be found empirically only: there are no definite rules, since it is really a question of personal preference. Knowing the lower frequency limit of the existing loudspeaker system, either through personal measurement or from manufacturers' data, is a help, however, since the cross-over frequency of the subwoofer can then be chosen close to this limit.

The cross-over frequency chosen in the prototype is different from that found in many popular