

**SERIAL ACCESS SPI BUS 8K (1024 x 8) EEPROM**

PRELIMINARY DATA

- 100,000 ERASE/WRITE CYCLES
- 10 YEARS DATA RETENTION
- SINGLE 4.5V to 5.5V SUPPLY VOLTAGE
- SPI BUS COMPATIBLE SERIAL INTERFACE
- 2 MHz CLOCK RATE MAX
- BLOCK WRITE PROTECTION
- STATUS REGISTER
- 16 BYTE PAGE MODE
- WRITE PROTECT
- SELF-TIMED PROGRAMMING CYCLE
- E.S.D.PROTECTION GREATER than 4000V
- SUPPORTS POSITIVE CLOCK SPI MODES

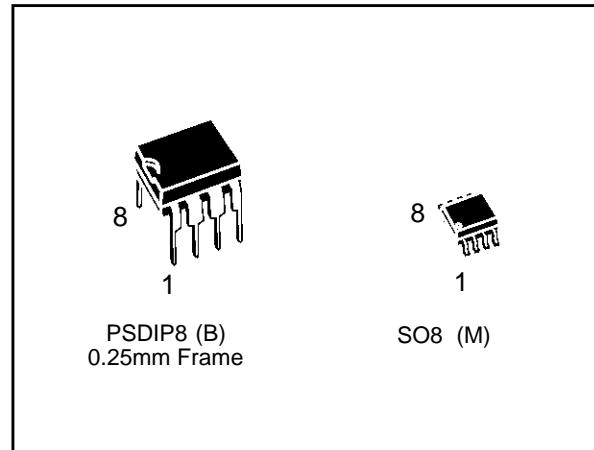

**DESCRIPTION**

The ST95080 is an 8K bit Electrically Erasable Programmable Memory (EEPROM) fabricated with SGS-THOMSON's High Endurance Single Polysilicon CMOS technology. The memory is accessed by a simple SPI bus compatible serial interface. The bus signals are a serial clock input (C), a serial data input (D) and a serial data output (Q).

**Table 1. Signal Names**

C	Serial Clock
D	Serial Data Input
Q	Serial Data Output
$\bar{S}$	Chip Select
$\bar{W}$	Write Protect
$\overline{HOLD}$	Hold
V <sub>CC</sub>	Supply Voltage
V <sub>SS</sub>	Ground

**Figure 1. Logic Diagram**

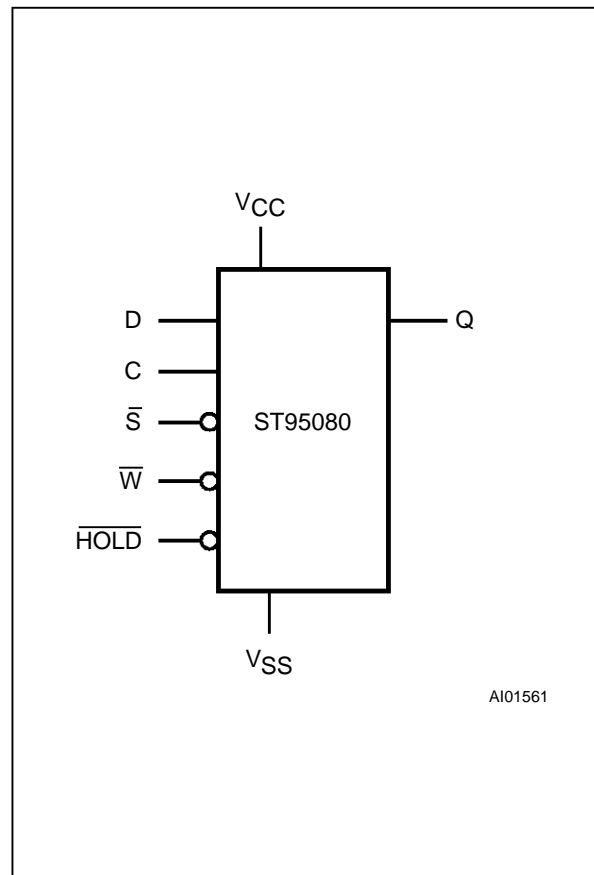

Figure 2A. DIP Pin Connections

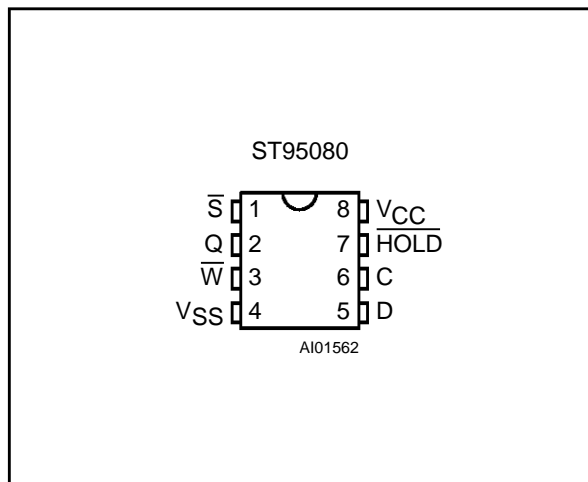

Figure 2B. SO Pin Connections

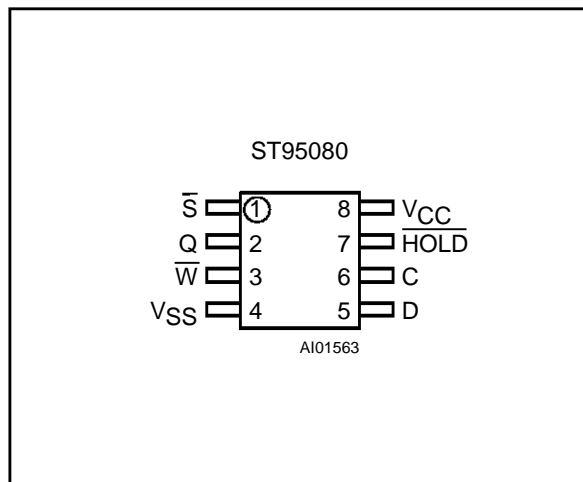

Table 2. Absolute Maximum Ratings (1)

Symbol	Parameter	Value	Unit
$T_A$	Ambient Operating Temperature: grade 1 grade 6	0 to 70 -40 to 85	°C
$T_{STG}$	Storage Temperature	-65 to 150	°C
$T_{LEAD}$	Lead Temperature, Soldering (SO8 package) (PSDIP8 package)	40 sec 10 sec	215 260 °C
$V_O$	Output Voltage	-0.3 to $V_{CC} + 0.6$	V
$V_I$	Input Voltage with respect to Ground	-0.3 to 6.5	V
$V_{CC}$	Supply Voltage	-0.3 to 6.5	V
$V_{ESD}$	Electrostatic Discharge Voltage (Human Body model) (2)	4000	V
	Electrostatic Discharge Voltage (Machine model) (3)	500	V

Notes: 1. Except for the rating "Operating Temperature Range", stresses above those listed in the Table "Absolute Maximum Ratings" may cause permanent damage to the device. These are stress ratings only and operation of the device at these or any other conditions above those indicated in the Operating sections of this specification is not implied. Exposure to Absolute Maximum Rating conditions for extended periods may affect device reliability. Refer also to the SGS-THOMSON SURE Program and other relevant quality documents.

2. MIL-STD-883C, 3015.7 (100pF, 1500Ω)

3. EIAJIC-121 (Condition C) (200pF, 0Ω)

DESCRIPTION (cont'd)

The device connected to the bus is selected when the chip select input ( $\bar{S}$ ) goes low. Communications with the chip can be interrupted with a hold input ( $\overline{HOLD}$ ). The write operation is disabled by a write protect input ( $\bar{W}$ ).

Data is clocked in during the low to high transition of clock C, data is clocked out during the high to low transition of clock C.

SIGNALS DESCRIPTION

**Serial Output (Q).** The output pin is used to transfer data serially out of the ST95080. Data is shifted out on the falling edge of the serial clock.

**Serial Input (D).** The input pin is used to transfer data serially into the device. It receives instructions, addresses, and the data to be written. Input is latched on the rising edge of the serial clock.

Figure 3. Data and Clock Timing

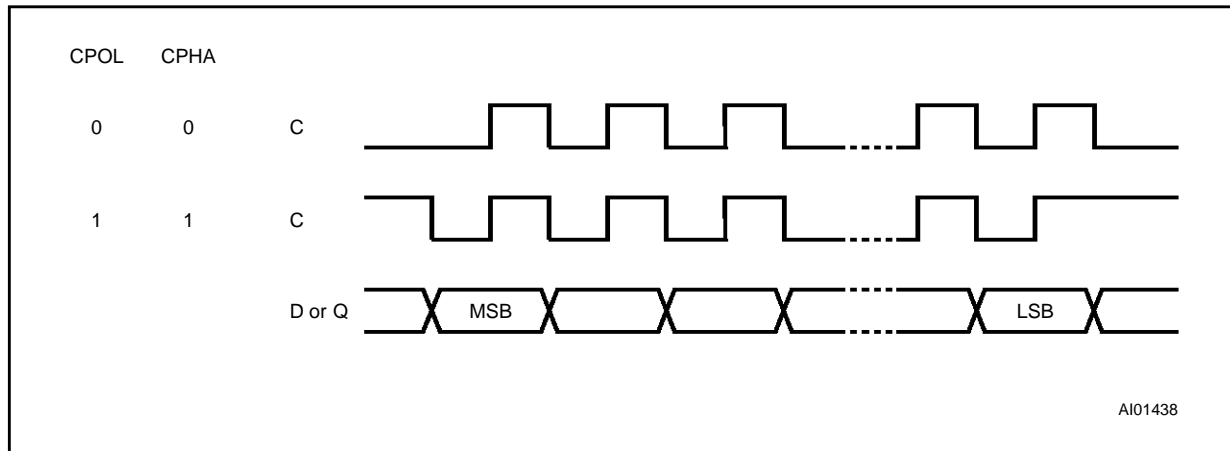
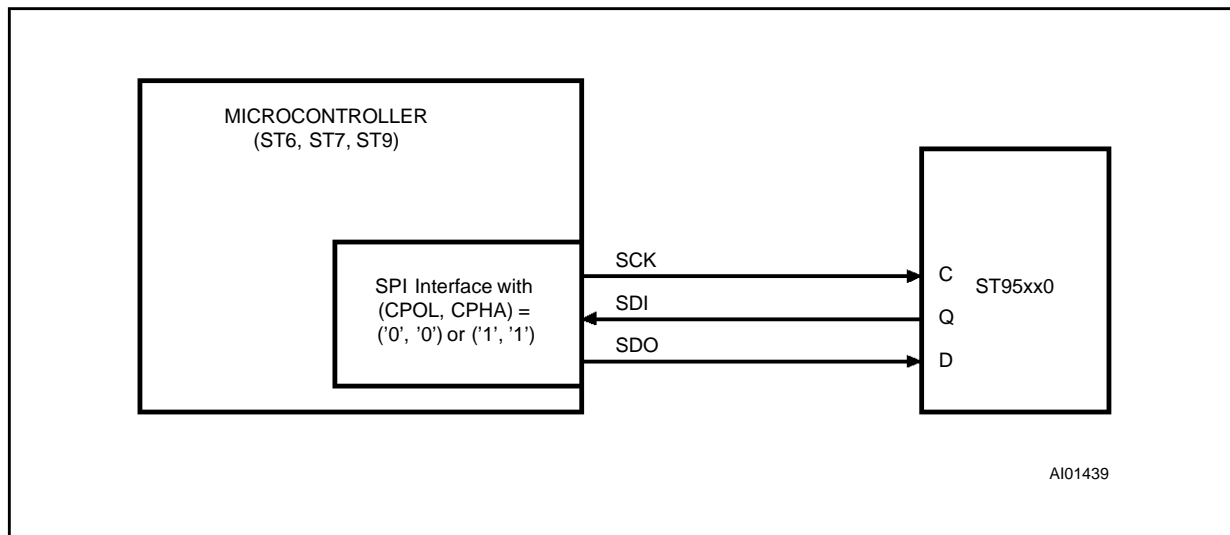

Figure 4. Microcontroller and SPI Interface Set-up



**Serial Clock (C).** The serial clock provides the timing of the serial interface. Instructions, addresses, or data present at the input pin are latched on the rising edge of the clock input, while data on the Q pin changes after the falling edge of the clock input.

**Chip Select ( $\bar{S}$ ).** When  $\bar{S}$  is high, the ST95080 is deselected and the D output pin is at high impedance and, unless an internal write operation is underway the ST95080 will be in the standby power mode.  $\bar{S}$  low enables the ST95080, placing it in the active power mode. It should be noted that after

power-on, a high to low transition on  $\bar{S}$  is required prior to the start of any operation.

**Write Protect ( $\bar{W}$ ).** This pin is for hardware write protection. When  $\bar{W}$  is low, writes to the ST95080 memory are disabled but any other operations stay enabled. When  $\bar{W}$  is high, all writes operations are available.  $\bar{W}$  going low at any time before the last bit D0 of the data stream will reset the write enable latch and prevent programming. No action on  $\bar{W}$  or on the write enable latch can interrupt a write cycle which has commenced.

**Hold ( $\overline{HOLD}$ ).** The  $\overline{HOLD}$  pin is used to pause serial communications with a ST95080 without re-setting the serial sequence. To take the Hold condition into account, the product must be selected ( $\overline{S} = 0$ ). Then the Hold state is validated by a high to low transition on  $\overline{HOLD}$  when C is low. To resume the communications,  $\overline{HOLD}$  is brought high while C is low. During the Hold condition D, Q, and C are at a high impedance state.

When the ST95080 is under the Hold condition, it is possible to deselect the device. However, the serial communications will remain paused after a reselect, and the chip will be reset.

The ST95080 can be driven by a microcontroller with its SPI peripheral running in either of the two following modes: (CPOL, CPHA) = ('0', '0') or (CPOL, CPHA) = ('1', '1').

For these two modes, input data is latched in by the low to high transition of clock C, and output data is available from the high to low transition of Clock (C).

The difference between (CPOL, CPHA) = (0, 0) and (CPOL, CPHA) = (1, 1) is the stand-by polarity: C remains at '0' for (CPOL, CPHA) = (0, 0) and C remains at '1' for (CPOL, CPHA) = (1, 1) when there is no data transfer.

**OPERATIONS**

All instructions, addresses and data are shifted in and out of the chip MSB first. Data input (D) is sampled on the first rising edge of clock (C) after the chip select ( $\overline{S}$ ) goes low. Prior to any operation, a one-byte instruction code must be entered in the chip. This code is entered via the data input (D), and latched on the rising edge of the clock input (C). To enter an instruction code, the product must have been previously selected ( $\overline{S} = \text{low}$ ). Table 3 shows the instruction set and format for device

operation. If an invalid instruction is sent (one not contained in Table 3), the chip is automatically deselected. For operations that read or write data in the memory array, bit 3 and 4 of the instruction are the MSB of the address, otherwise, it is a don't care.

**Write Enable (WREN) and Write Disable (WRDI)**

The ST95080 contains a write enable latch. This latch must be set prior to every WRITE or WRSR operation. The WREN instruction will set the latch and the WRDI instruction will reset the latch. The latch is reset under the following conditions:

- $\overline{W}$  pin is low
- Power on
- WRDI instruction executed
- WRSR instruction executed
- WRITE instruction executed

As soon as the WREN or WRDI instruction is received by the ST95080, the circuit executes the instruction and enters a wait mode until it is deselected.

**Read Status Register (RDSR)**

The RDSR instruction provides access to the status register. The status register may be read at any time, even during a write to the memory operation. As soon as the 8th bit of the status register is read out, the ST95080 enters a wait mode (data on D is not decoded, Q is in Hi-Z) until it is deselected.

The status register format is as follows:

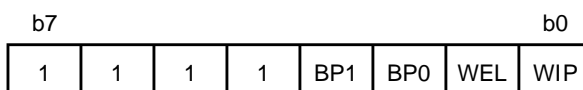

BP1, BP0: Read and write bits  
 WEL, WIP: Read only bits.  
 b7 to b4: Read only bits.

**Table 3. Instruction Set**

Instruction	Description	Instruction Format
WREN	Set Write Enable Latch	000X X110
WRDI	Reset Write Enable Latch	000X X100
RDSR	Read Status Register	000X X101
WRSR	Write Status Register	000X X001
READ	Read Data from Memory Array	000A A011
WRITE	Write Data to Memory Array	000A A010

**Notes:** A = 1, Upper page selected  
 A = 0, Lower page selected  
 X = Don't care

Figure 5. Block Diagram

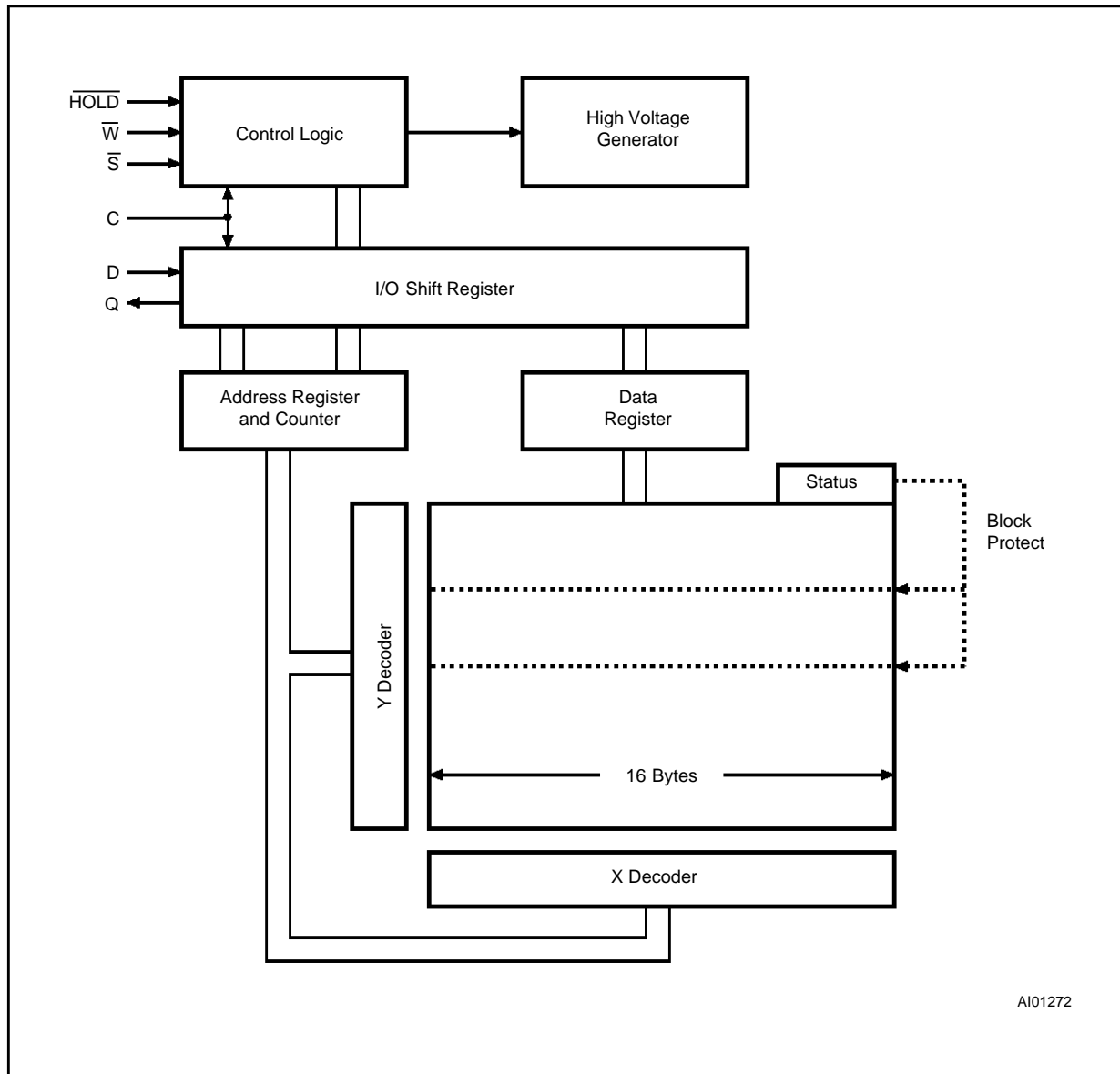

During a write to the memory operation to the memory array, all bits BP1, BP0, WEL, WIP are valid and can be read. During a write to the status register, only the bits WEL and WIP are valid and can be read. The values of BP1 and BP0 read at that time correspond to the previous contents of the status register.

The Write-In-Process (WIP) read-only bit indicates whether the ST95080 is busy with a write opera-

tion. When set to a '1' a write is in progress, when set to a '0' no write is in progress.

The Write Enable Latch (WEL) read-only bit indicates the status of the write enable latch. When set to a '1' the latch is set, when set to a '0' the latch is reset. The Block Protect (BP0 and BP1) bits indicate the extent of the protection employed. These bits are set by the user issuing the WRSR instruction. These bits are non-volatile.

Figure 6. Read Operation Sequence

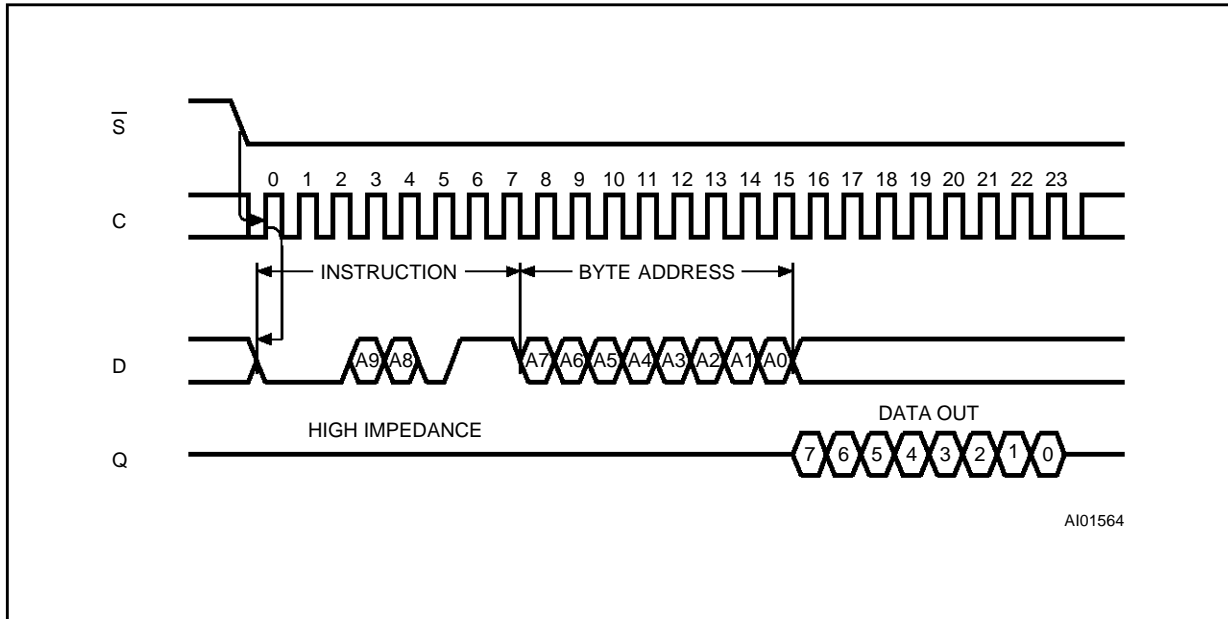

Table 4. Write Protected Block Size

Status Register Bits		Array Addresses Protected	Protected Block
BP1	BP0		
0	0	none	none
0	1	300h - 3FFh	Upper quarter
1	0	200h - 3FFh	Upper half
1	1	000h - 3FFh	Whole memory

**Write Status Register (WRSR)**

The WRSR instruction allows the user to select the size of protected memory. The ST95080 is divided into four 2048 bit blocks. The user may read the blocks but will be unable to write within the protected blocks. The blocks and respective WRSR control bits are shown in Table 4.

When the WRSR instruction and the 8 bits of the Status Register are latched-in, the internal write cycle is then triggered by the rising edge of  $\bar{S}$ .

This rising edge of  $\bar{S}$  must appear no later than the 16th clock cycle of the WRSR instruction of the Status Register content (it must not appear a 17th clock pulse before the rising edge of  $\bar{S}$ ), otherwise the internal write sequence is not performed.

**Read Operation**

The chip is first selected by putting  $\bar{S}$  low. The serial one byte read instruction is followed by a one byte address (A7-A0), each bit being latched-in during the rising edge of the clock (C). Bit 3 and 4 of the read instruction contains address bit A9 and A8 (most significant address bit, see Table 3). Then the data stored in the memory at the selected address is shifted out on the Q output pin; each bit being shifted out during the falling edge of the clock (C). The data stored in the memory at the next address can be read in sequence by continuing to provide clock pulses. The byte address is automatically incremented to the next higher address after each byte of data is shifted out. When the highest address is reached, the address counter rolls over to 0h allowing the read cycle to be continued indefinitely. The read operation is terminated by deselecting the chip. The chip can be deselected at any time during data output. Any read attempt during a write cycle will be rejected and will deselect the chip.

Figure 7. Write Enable Latch Sequence

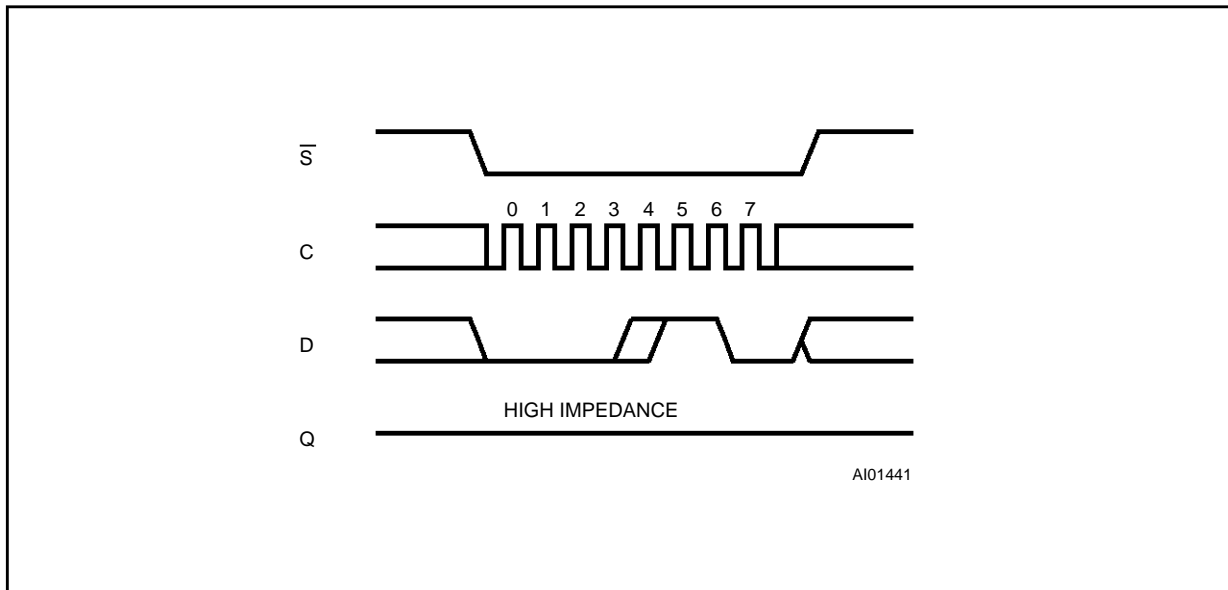

Figure 8. Byte Write Operation Sequence

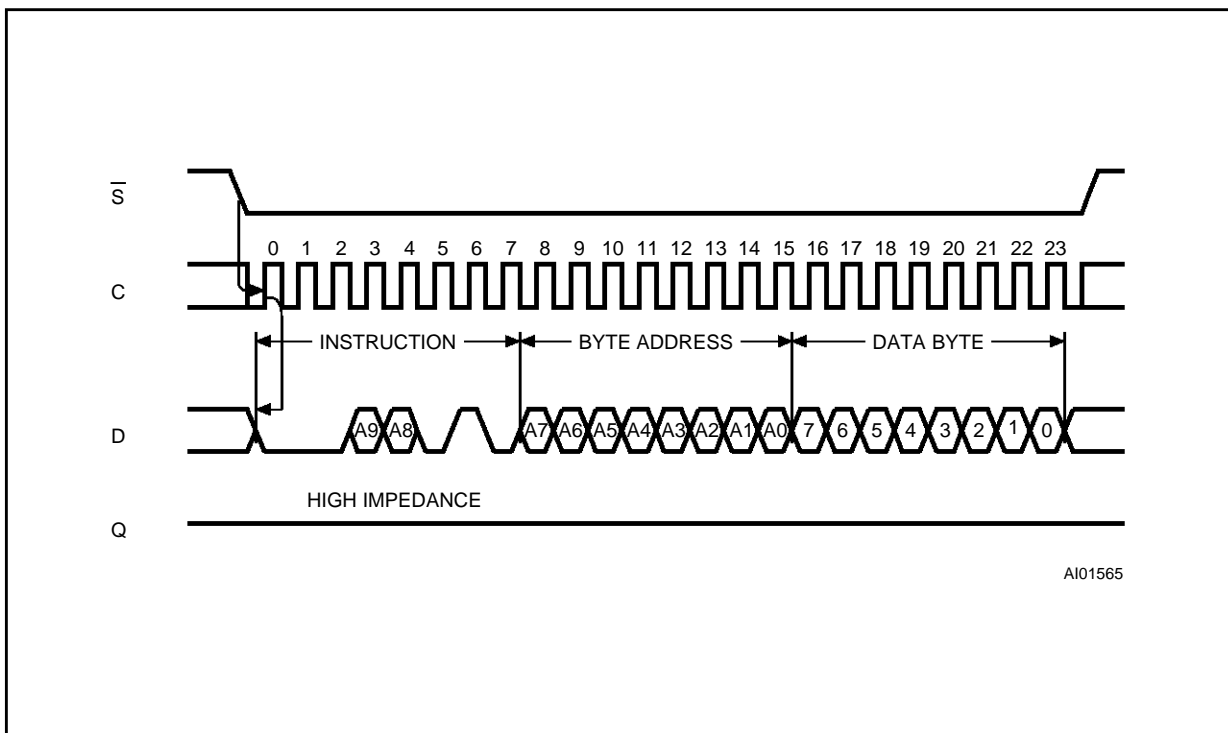

Figure 9. Page Write Operation Sequence

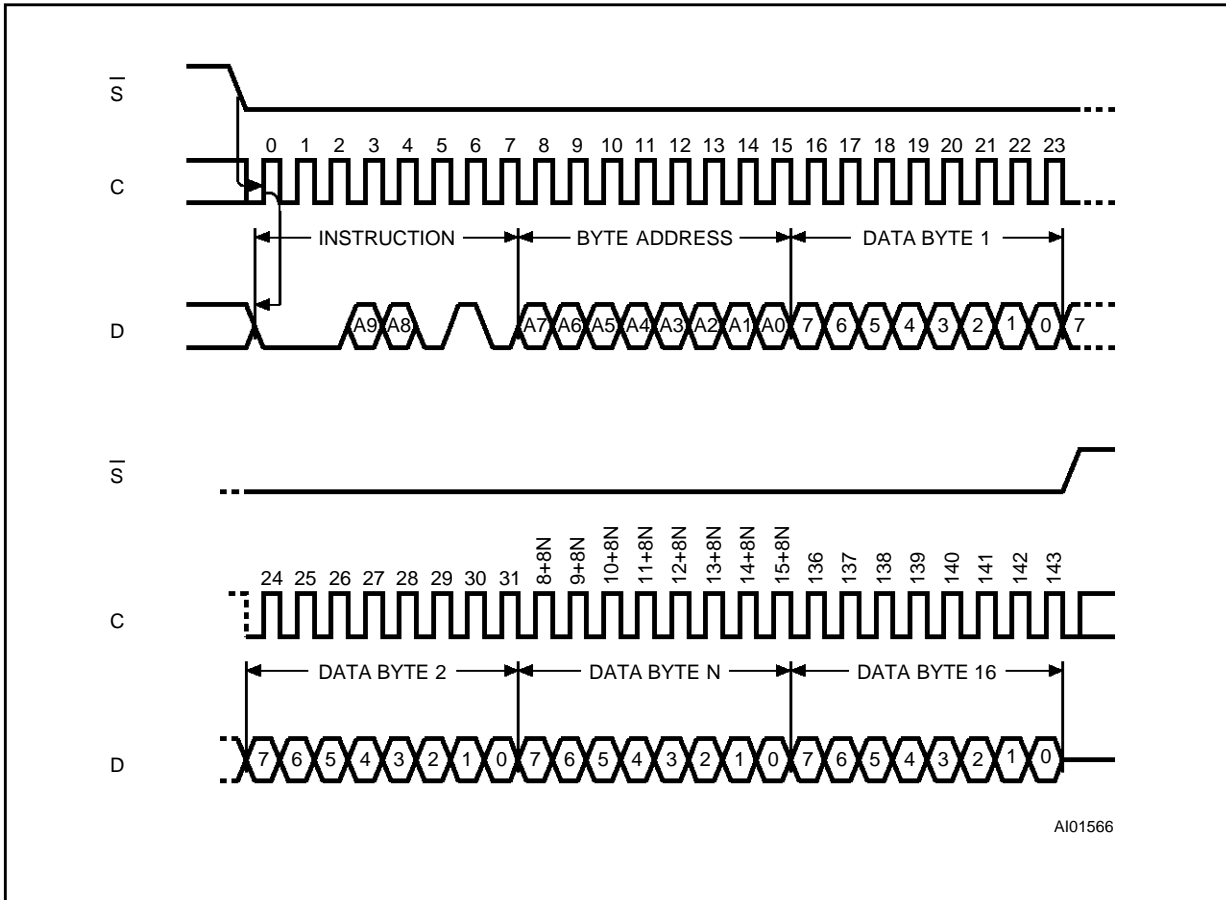

Figure 10. RDSR: Read Status Register Sequence

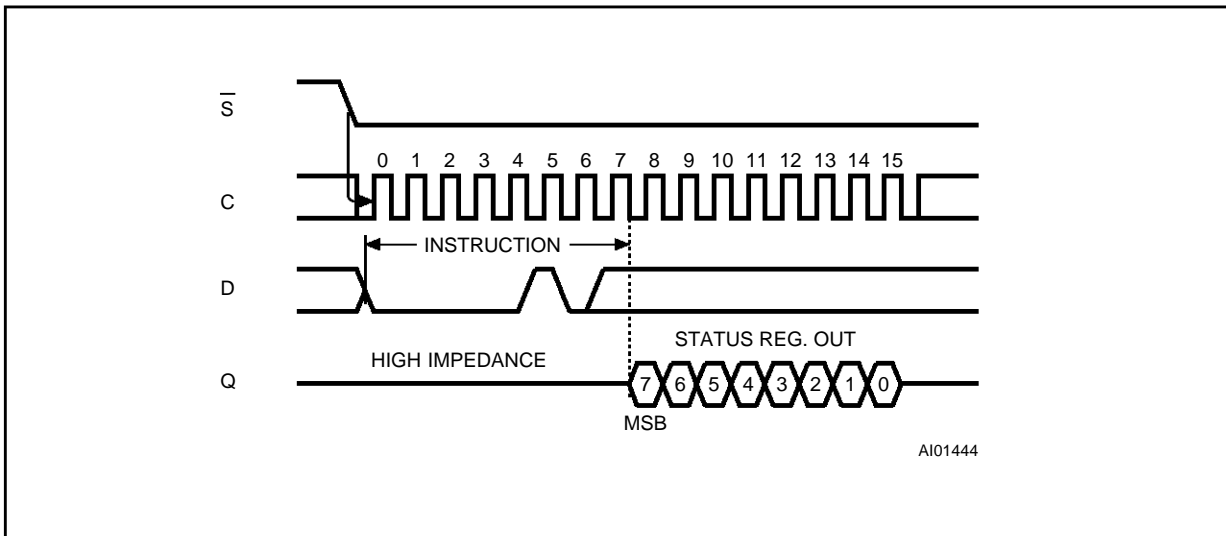
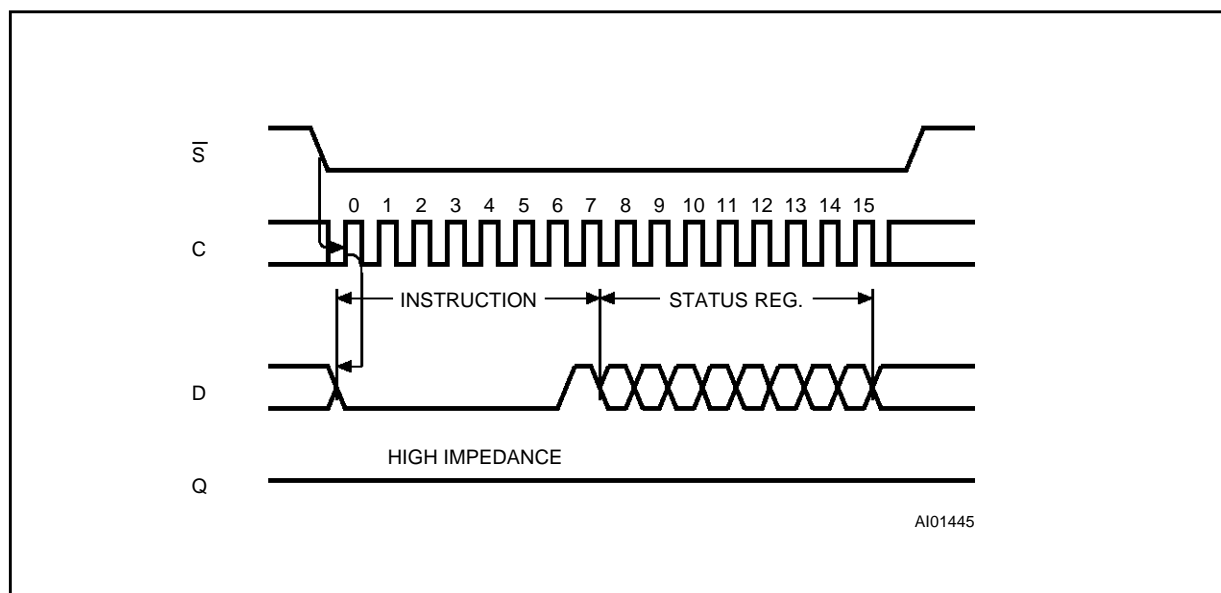



Figure 11. WRSR: Write Status Register Sequence



### Byte Write Operation

Prior to any write attempt, the write enable latch must be set by issuing the WREN instruction. First the device is selected ( $\bar{S}$  = low) and a serial WREN instruction byte is issued. Then the product is deselected by taking  $\bar{S}$  high. After the WREN instruction byte is sent, the ST95080 will set the write enable latch and then remain in standby until it is deselected. Then the write state is entered by selecting the chip, issuing two bytes of instruction and address, and one byte of data.

Chip Select ( $\bar{S}$ ) must remain low for the entire duration of the operation. The product must be deselected just after the eighth bit of data has been latched in. If not, the write process is cancelled. As soon as the product is deselected, the self-timed write cycle is initiated. While the write is in progress, the status register may be read to check BP1, BP0, WEL and WIP. WIP is high during the self-timed write cycle. When the cycle is completed, the write enable latch is reset.

### Page Write Operation

A maximum of 16 bytes of data may be written during one non-volatile write cycle. All 16 bytes

must reside on the same page. The page write mode is the same as the byte write mode except that instead of deselecting the device after the first byte of data, up to 15 additional bytes can be shifted in prior to deselecting the chip. A page address begins with address xxxx 0000 and ends with xxxx 1111. If the address counter reaches xxxx 1111 and the clock continues, the counter will roll over to the first address of the page (xxxx 0000) and overwrite any previously written data. The programming cycle will only start if the  $\bar{S}$  transition occurs just after the eighth bit of data of a word is received.

### POWER ON STATE

After a Power up the ST95080 is in the following state:

- The device is in the low power standby state.
- The chip is deselected.
- The chip is not in hold condition.
- The write enable latch is reset.
- BP1 and BP0 are unchanged (non-volatile bits).

Figure 12. EEPROM and SPI Bus

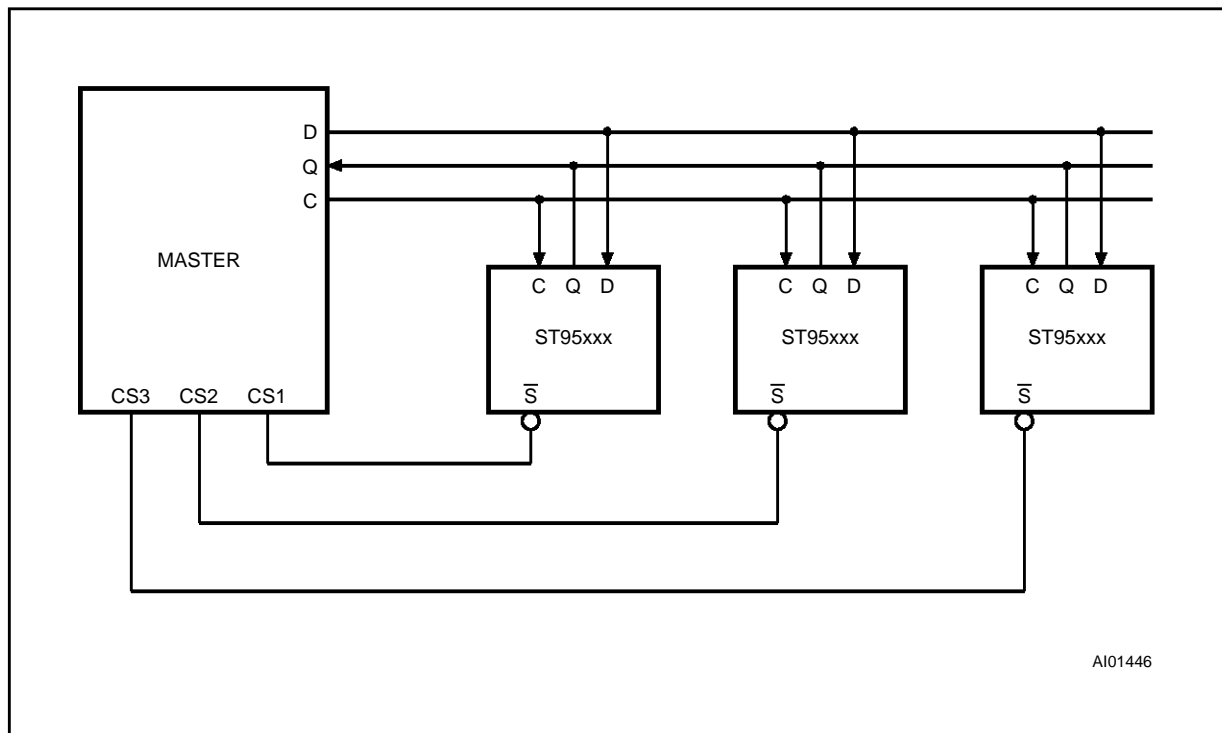
**DATA PROTECTION AND PROTOCOL SAFETY**

- All inputs are protected against noise, see Table 5.
- Non valid  $\overline{CS}$  and  $\overline{HOLD}$  transitions are not taken into account.
- $\overline{CS}$  must come high at the proper clock count in order to start a non-volatile write cycle (in the memory array or in the cycle status register), that is the Chip Select  $\overline{CS}$  must rise during the clock pulse following the introduction of a multiple of 8 bits.
- Access to the memory array during non-volatile programming cycle is ignored; however, the programming cycle continues.

- After any of the operations WREN, WRDI, RDSR is completed, the chip enters a wait state and waits for a deselect.
- The write enable latch is reset upon power-up.
- The write enable latch is reset when  $\overline{W}$  is brought low.

**INITIAL DELIVERY STATE**

The device is delivered with the memory array in a fully erased state (all data set at all "1's" or FFh). The block protect bits are initialized to 00.

**Table 5. Input Parameters** <sup>(1)</sup> ( $T_A = 25\text{ }^\circ\text{C}$ ,  $f = 2\text{ MHz}$ )

Symbol	Parameter	Min	Max	Unit
$C_{IN}$	Input Capacitance (D)		8	pF
$C_{IN}$	Input Capacitance (other pins)		6	pF
$t_{LPF}$	Input Signal Pulse Width Filtered Out		10	ns

**Note:** 1. Sampled only, not 100% tested.

**Table 6. DC Characteristics**

( $T_A = 0\text{ to }70\text{ }^\circ\text{C}$  or  $-40\text{ to }85\text{ }^\circ\text{C}$ ;  $V_{CC} = 4.5\text{V to }5.5\text{V}$ )

Symbol	Parameter	Test Condition	Min	Max	Unit
$I_{LI}$	Input Leakage Current			2	$\mu\text{A}$
$I_{LO}$	Output Leakage Current			$\pm 2$	$\mu\text{A}$
$I_{CC}$	$V_{CC}$ Supply Current (Active)	$C = 0.1 V_{CC}/0.9 V_{CC}$ , @ 2 MHz, Q = Open		2	mA
$I_{CC1}$	$V_{CC}$ Supply Current (Standby)	$\bar{S} = V_{CC}$ , $V_{IN} = V_{SS}$ or $V_{CC}$		50	$\mu\text{A}$
$V_{IL}$	Input Low Voltage		-0.3	$0.3 V_{CC}$	V
$V_{IH}$	Input High Voltage		$0.7 V_{CC}$	$V_{CC} + 1$	V
$V_{OL}^{(1)}$	Output Low Voltage	$I_{OL} = 2\text{mA}$		0.4	V
$V_{OH}^{(1)}$	Output High Voltage	$I_{OH} = -2\text{mA}$	$V_{CC} - 0.6$		V

**Note:** 1. The device meets output requirements for both TTL and CMOS standards.

### AC MEASUREMENT CONDITIONS

Input Rise and Fall Times	$\leq 50\text{ns}$
Input Pulse Voltages	$0.2V_{CC}$ to $0.8V_{CC}$
Input and Output Timing Reference Voltages	$0.3V_{CC}$ to $0.7V_{CC}$
Output Load	$C_L = 100\text{pF}$

Note that Output Hi-Z is defined as the point where data is no longer driven.

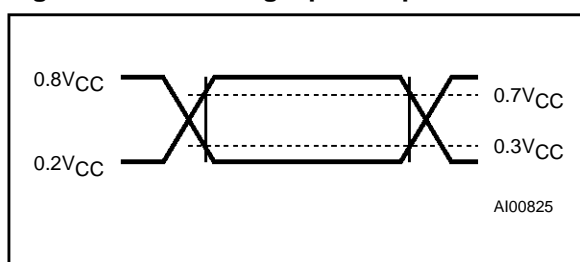
**Figure 13. AC Testing Input Output Waveforms**

**Table 7. AC Characteristics**(T<sub>A</sub> = 0 to 70°C or -40 to 85°C; V<sub>CC</sub> = 4.5V to 5.5V)

Symbol	Alt	Parameter	Test Condition	Min	Max	Unit
f <sub>C</sub>	f <sub>C</sub>	Clock Frequency		D.C.	2	MHz
t <sub>SLCH</sub>	t <sub>CSS</sub>	$\overline{S}$ Active Setup Time (relative to the rising edge of C)		100		ns
t <sub>CHSL</sub>		$\overline{S}$ Not Active Hold Time (relative to the rising edge of C)		100		ns
t <sub>CH</sub> <sup>(1)</sup>	t <sub>CLH</sub>	Clock High Time		150		ns
t <sub>CL</sub> <sup>(1)</sup>	t <sub>CLL</sub>	Clock Low Time		200		ns
t <sub>CLCH</sub>	t <sub>RC</sub>	Clock Rise Time			1	μs
t <sub>CHCL</sub>	t <sub>FC</sub>	Clock Fall Time			1	μs
t <sub>DVCH</sub>	t <sub>DSU</sub>	Data In Setup Time		50		ns
t <sub>CHDX</sub>	t <sub>DH</sub>	Data In Hold Time		50		ns
t <sub>DLDH</sub>	t <sub>RI</sub>	Data In Rise Time			1	μs
t <sub>DHDL</sub>	t <sub>FI</sub>	Data In Fall Time			1	μs
t <sub>HHCH</sub>	t <sub>HSU</sub>	$\overline{HOLD}$ Setup Time		100		ns
t <sub>HLCH</sub>		Clock Low Hold Time after $\overline{HOLD}$ Active		100		ns
t <sub>CLHL</sub>	t <sub>HH</sub>	$\overline{HOLD}$ Hold Time		80		ns
t <sub>CLHH</sub>		Clock Low Set-up Time before $\overline{HOLD}$ Inactive		100		ns
t <sub>CHSH</sub>		$\overline{S}$ Active Hold Time (relative to the rising edge of C)		200		ns
t <sub>SHCH</sub>		$\overline{S}$ Not Active Setup Time (relative to the rising edge of C)		100		ns
t <sub>SHSL</sub>	t <sub>CSH</sub>	$\overline{S}$ Deselect Time		200		ns
t <sub>SHQZ</sub>	t <sub>DIS</sub>	Output Disable Time			150	ns
t <sub>CLQV</sub>	t <sub>V</sub>	Clock Low to Output Valid			190	ns
t <sub>CLQX</sub>	t <sub>HO</sub>	Output Hold Time		0		ns
t <sub>QLQH</sub> <sup>(2)</sup>	t <sub>RO</sub>	Output Rise Time			100	ns
t <sub>QHQL</sub> <sup>(2)</sup>	t <sub>FO</sub>	Output Fall Time			100	ns
t <sub>HHQX</sub>	t <sub>LZ</sub>	$\overline{HOLD}$ High to Output Low-Z			100	ns
t <sub>HLQZ</sub>	t <sub>HZ</sub>	$\overline{HOLD}$ Low to Output High-Z			200	ns
t <sub>W</sub>	t <sub>WP</sub>	Write Cycle Time			10	ms

Notes: 1. t<sub>CH</sub> + t<sub>CL</sub> ≤ 1/f<sub>C</sub>

2. Value guaranteed by characterization, not 100% tested in production.

Figure 14. Serial Input Timing

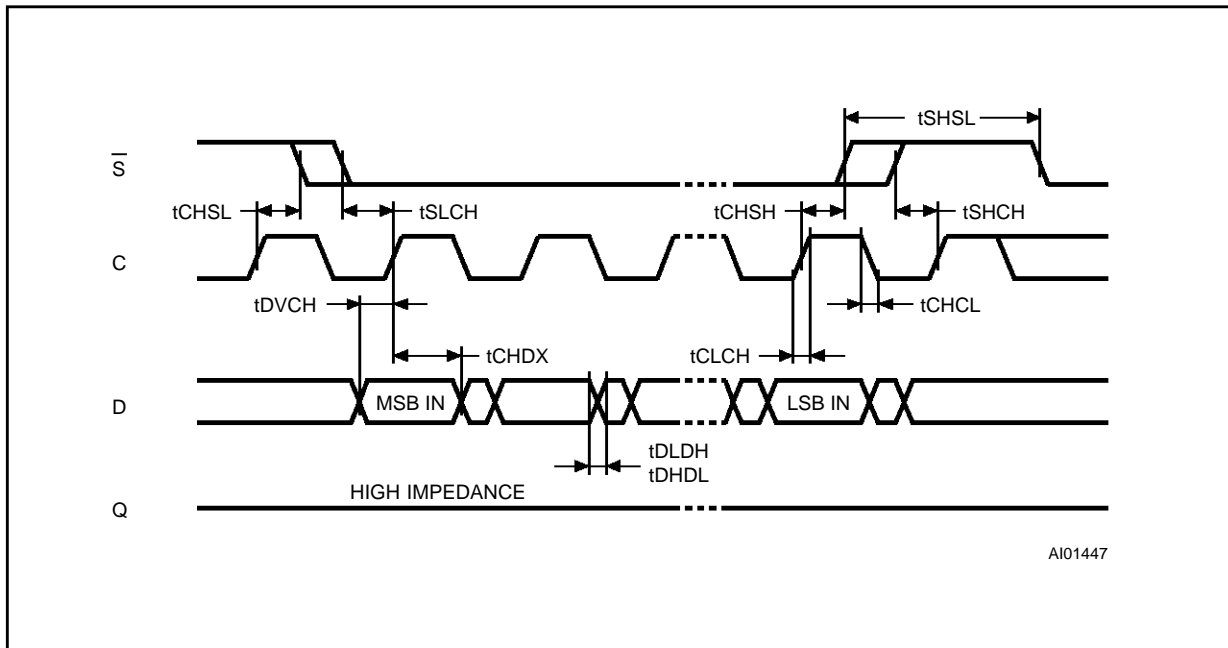

Figure 15. Hold Timing

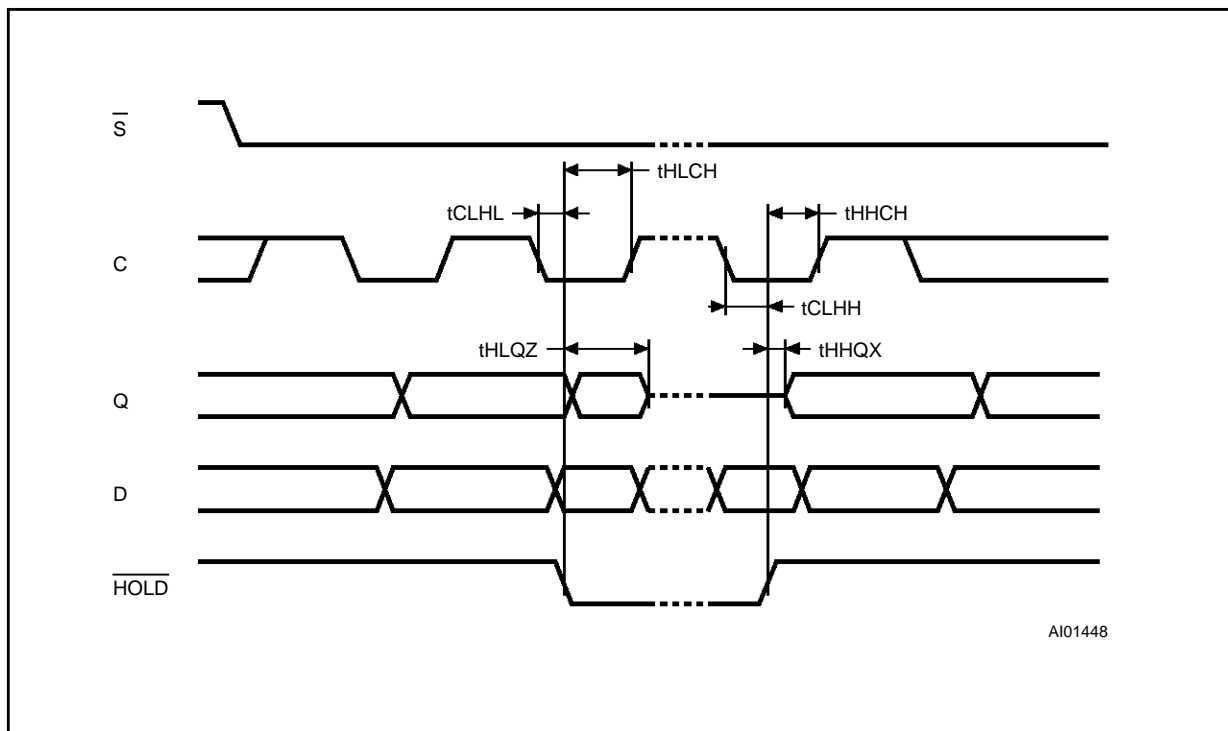
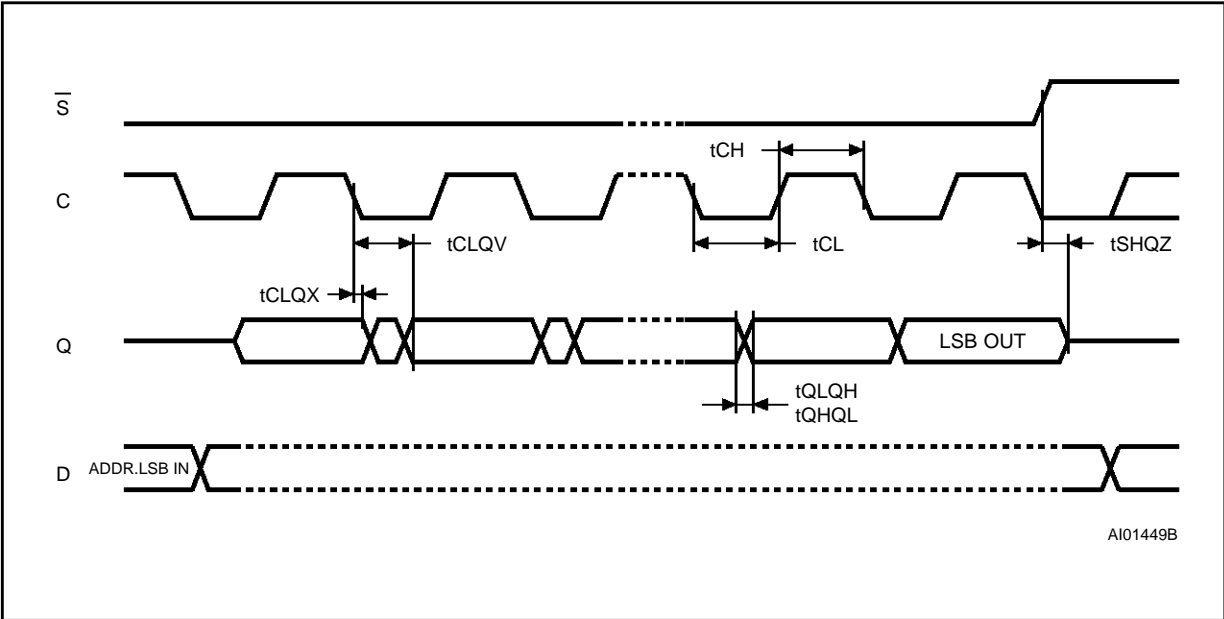
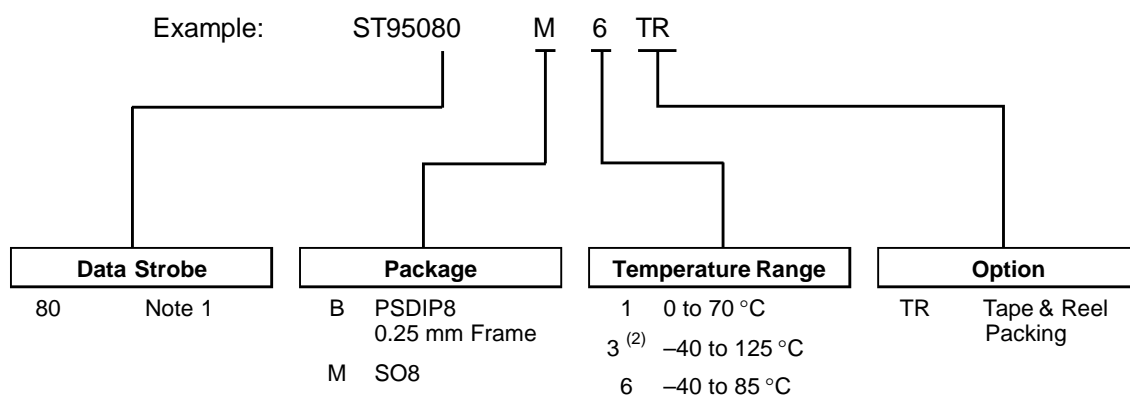

Figure 16. Output Timing



## ORDERING INFORMATION SCHEME



**Notes:** 1. Data In is strobed on rising edge of the clock (C) and Data Out is synchronized from the falling edge of the clock.  
2. Temperature range on special request only.

For a list of available options (Package, Temperature Range, etc...) refer to the current Memory Shortform catalogue.

For further information on any aspect of this device, please contact the SGS-THOMSON Sales Office nearest to you.

**PSDIP8 - 8 pin Plastic Skinny DIP, 0.25mm lead frame**

Symb	mm			inches		
	Typ	Min	Max	Typ	Min	Max
A		3.90	5.90		0.154	0.232
A1		0.49	–		0.019	–
A2		3.30	5.30		0.130	0.209
B		0.36	0.56		0.014	0.022
B1		1.15	1.65		0.045	0.065
C		0.20	0.36		0.008	0.014
D		9.20	9.90		0.362	0.390
E	7.62	–	–	0.300	–	–
E1		6.00	6.70		0.236	0.264
e1	2.54	–	–	0.100	–	–
eA		7.80	–		0.307	–
eB			10.00			0.394
L		3.00	3.80		0.118	0.150
N		8			8	
CP			0.10			0.004

PSDIP8

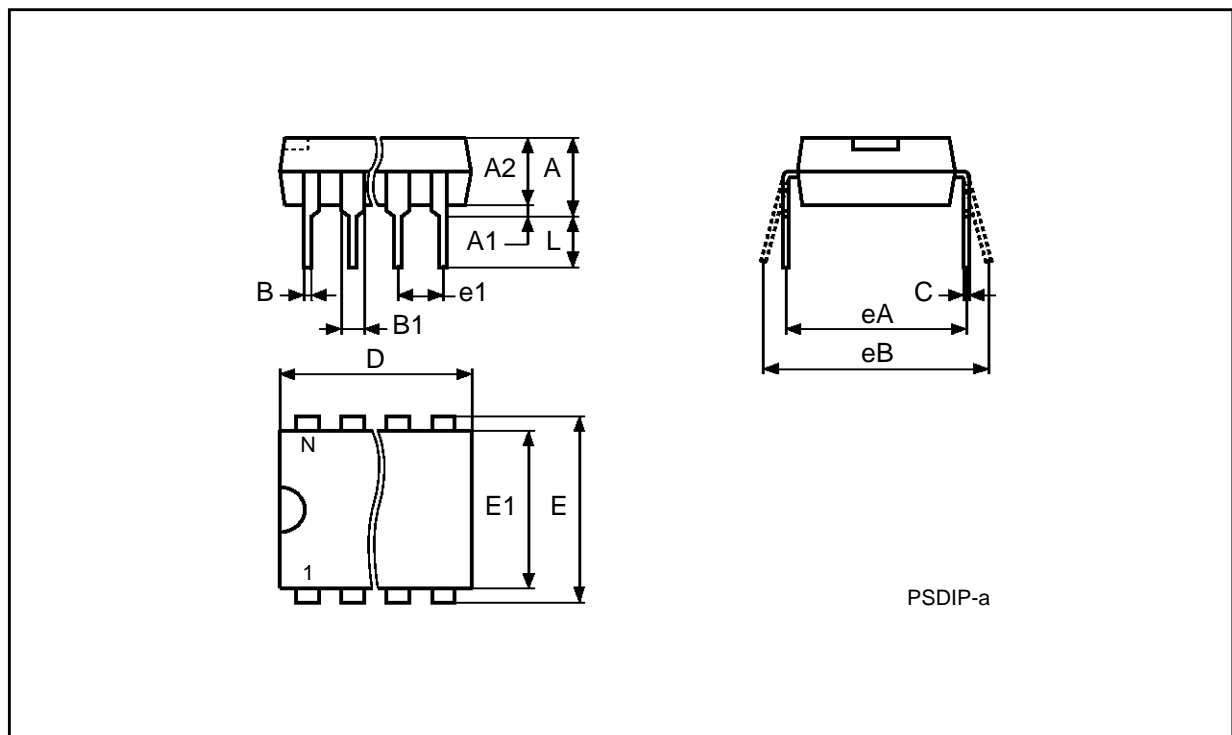

Drawing is not to scale



### SO8 - 8 lead Plastic Small Outline, 150 mils body width

Symb	mm			inches		
	Typ	Min	Max	Typ	Min	Max
A		1.35	1.75		0.053	0.069
A1		0.10	0.25		0.004	0.010
B		0.33	0.51		0.013	0.020
C		0.19	0.25		0.007	0.010
D		4.80	5.00		0.189	0.197
E		3.80	4.00		0.150	0.157
e	1.27	–	–	0.050	–	–
H		5.80	6.20		0.228	0.244
h		0.25	0.50		0.010	0.020
L		0.40	0.90		0.016	0.035
$\alpha$		0°	8°		0°	8°
N	8			8		
CP			0.10			0.004

SO8

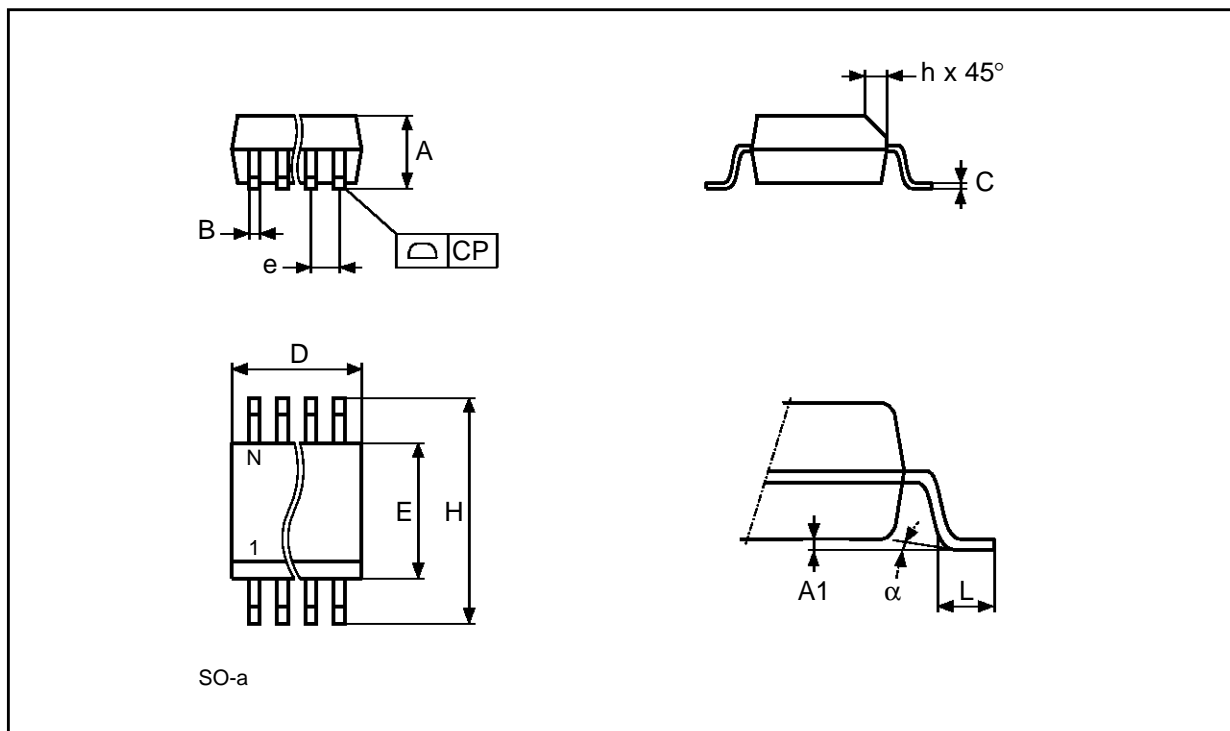

Drawing is not to scale

Information furnished is believed to be accurate and reliable. However, SGS-THOMSON Microelectronics assumes no responsibility for the consequences of use of such information nor for any infringement of patents or other rights of third parties which may result from its use. No license is granted by implication or otherwise under any patent or patent rights of SGS-THOMSON Microelectronics. Specifications mentioned in this publication are subject to change without notice. This publication supersedes and replaces all information previously supplied. SGS-THOMSON Microelectronics products are not authorized for use as critical components in life support devices or systems without express written approval of SGS-THOMSON Microelectronics.

© 1995 SGS-THOMSON Microelectronics - All Rights Reserved

SGS-THOMSON Microelectronics GROUP OF COMPANIES  
Australia - Brazil - China - France - Germany - Hong Kong - Italy - Japan - Korea - Malaysia - Malta - Morocco - The Netherlands -  
Singapore - Spain - Sweden - Switzerland - Taiwan - Thailand - United Kingdom - U.S.A.