

# DATA SHEET

## **TEA1102; TEA1102T; TEA1102TS**

Fast charge ICs for NiCd, NiMH,  
SLA and Lilon

Preliminary specification  
Supersedes data of 1997 Oct 09  
File under Integrated Circuits, IC03

1999 Jan 27

## Fast charge ICs for NiCd, NiMH, SLA and Lilon

## TEA1102; TEA1102T; TEA1102TS

### FEATURES

- Safe and fast charging of Nickel Cadmium (NiCd), Nickel Metal Hydride (NiMH), Lithium Ion (Lilon), and Sealed Lead Acid (SLA) batteries
- Three charge states for NiCd or NiMH; fast, top-off and trickle or voltage regulation (optional)
- Two charge states for Lilon or SLA; current and voltage limited
- Adjustable fast charge current [0.5CA to 5CA nominal (CA = Capacity Amperes)]
- DC top-off and pulsating trickle charge current (NiCd and NiMH)
- Temperature dependent  $\Delta T/\Delta t$  battery full detection
- Automatic switch-over to accurate peak voltage detection ( $-1/4\%$ ) if no NTC is applied
- Possibility to use both  $\Delta T/\Delta t$  and peak voltage detection as main fast charge termination
- Support of inhibit during all charging states
- Manual refresh with regulated adjustable discharge current (NiCd and NiMH)
- Voltage regulation in the event of no battery
- Support of battery voltage based charge indication and buzzer signalling at battery insertion, end of refresh and at full detection
- Single, dual and separate LED outputs for indication of charge status state
- Minimum and maximum temperature protection
- Time-out protection
- Short-circuit battery voltage protection
- Can be applied with few low-cost external components.

### GENERAL DESCRIPTION

The TEA1102x are fast charge ICs which are able fast charge NiCd and NiMH, SLA and Lilon batteries.

The main fast charge termination for NiCd and NiMH batteries are  $\Delta T/\Delta t$  and peak voltage detection, both of which are well proven techniques. The TEA1102x automatically switches over from  $\Delta T/\Delta t$  to peak voltage detection if the thermistor fails or is not present. The  $\Delta T/\Delta t$  detection sensitivity is temperature dependent, thus avoiding false charge termination. Three charge states can be distinguished; fast, top-off and trickle.

Charging Lilon and SLA batteries is completely different. When the batteries reach their maximum voltage (adjustable), the TEA1102x switches over from current regulation to voltage regulation. After a defined time period, which is dependent on battery capacity and charge current, charge is terminated. Due to small self discharge rates of Lilon and SLA batteries, trickle charge can be omitted.

Several LEDs, as well as a buzzer, can be connected to the TEA1102x for indicating battery insertion, charge states, battery full condition and protection mode.

The TEA1102x are contained in a 20-pin package and are manufactured in a BiCMOS process, essentially for integrating the complex mix of requirements in a single chip solution. Only a few external low cost components are required in order to build a state of the art charger.

### ORDERING INFORMATION

TYPE NUMBER	PACKAGE		
	NAME	DESCRIPTION	VERSION
TEA1102	DIP20	plastic dual in-line package; 20 leads (300 mil)	SOT 146-1
TEA1102T	SO20	plastic small outline package; 20 leads; body width 7.5 mm	SOT163-1
TEA1102TS	SSOP20	plastic shrink small outline package; 20 leads; body width 5.3 mm	SOT339-1

Fast charge ICs for NiCd, NiMH, SLA and  
LilonTEA1102; TEA1102T;  
TEA1102TS

## QUICK REFERENCE DATA

SYMBOL	PARAMETER	CONDITIONS	MIN.	TYP.	MAX.	UNIT
$V_P$	supply voltage		5.5	–	11.5	V
$I_P$	supply current	outputs off	–	4	–	mA
$\Delta V_{NTC}/V_{NTC}$	temperature rate dependent ( $\Delta T/\Delta t$ ) detection level	$V_{NTC} = 2 \text{ V};$ $T_j = 0 \text{ to } 50 \text{ }^\circ\text{C}$	–	–0.25	–	%
$\Delta V_{bat}/V_{bat}$	voltage peak detection level with respect to top value	$V_{bat} = 2 \text{ V};$ $T_j = 0 \text{ to } 50 \text{ }^\circ\text{C}$	–	–0.25	–	%
$I_{Vbat}$	input current battery monitor	$V_{bat} = 0.3 \text{ to } 1.9 \text{ V}$	–	1	–	nA
$V_{bat(l)}$	voltage at pin 19 for detecting low battery voltage		–	0.30	–	V
$I_{IB}$	battery charge current	fast charge	10	–	100	$\mu\text{A}$
		top-off mode	–	3	–	$\mu\text{A}$
$I_{IB(max)}$	maximum battery charge current	voltage regulation full NiCd and NiMH battery	–	10	–	$\mu\text{A}$
$I_{IB(Lmax)}$	maximum load current	no battery	–	40	–	$\mu\text{A}$
$f_{osc}$	oscillator frequency		10	–	200	kHz
$V_{reg}$	regulating voltage	Lilon	–	1.37	–	V
		SLA	–	1.63	–	V
		NiCd and NiMH (pin $V_{stb}$ open-circuit)	–	1.325 or $V_{stb}$	–	V
		open battery	–	1.9	–	V

Fast charge ICs for NiCd, NiMH, SLA and  
Lilon

TEA1102; TEA1102T;  
TEA1102TS

BLOCK DIAGRAM

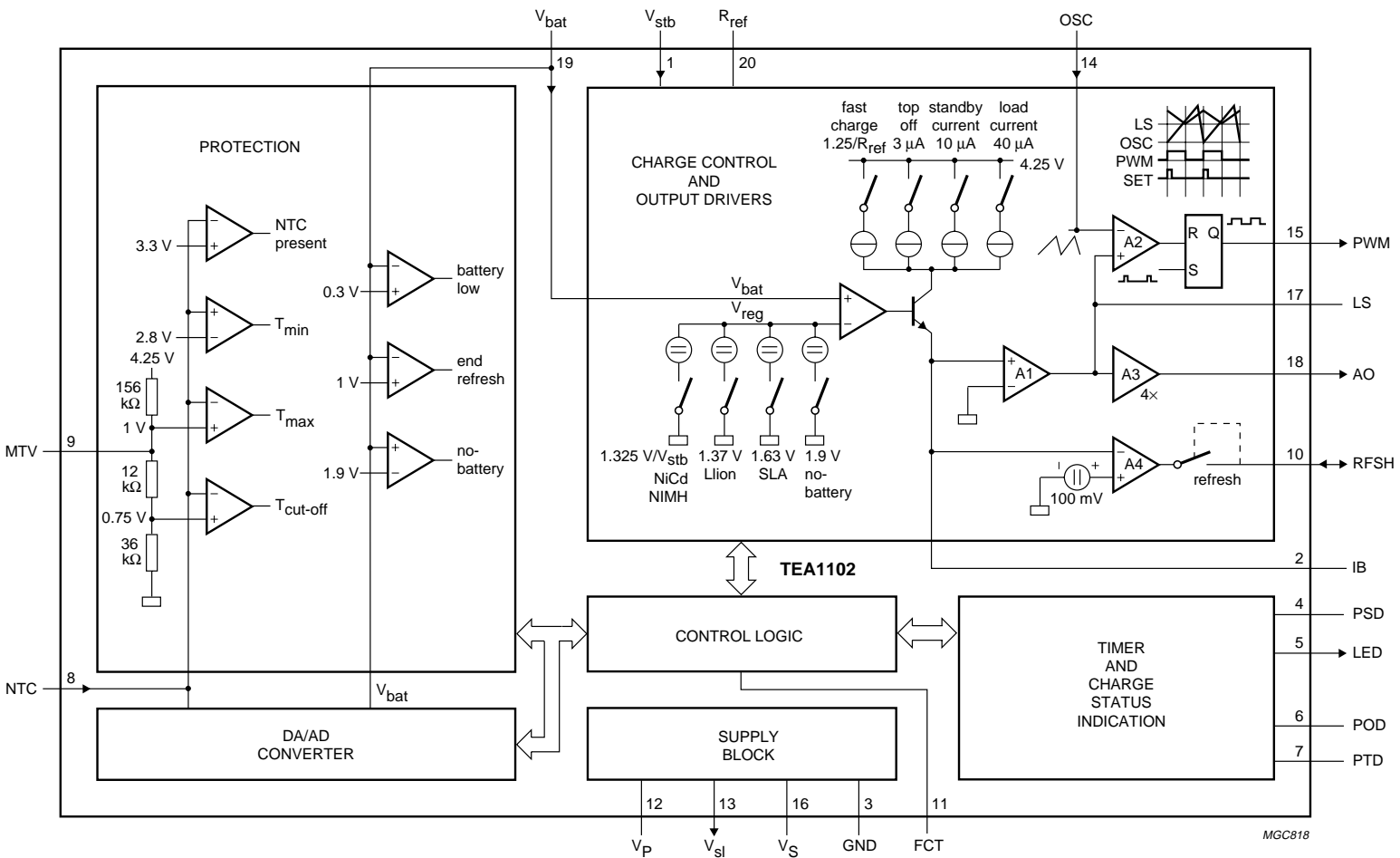

Fig.1 Block diagram.

Fast charge ICs for NiCd, NiMH, SLA and Lilon

TEA1102; TEA1102T;  
TEA1102TS

**PINNING**

SYMBOL	PIN	DESCRIPTION
V <sub>stb</sub>	1	standby regulation voltage input (NiCd and NiMH)
IB	2	charge current setting
GND	3	ground
PSD	4	program pin sample divider
LED	5	LED output
POD	6	program pin oscillator divider
PTD	7	program pin time-out divider
NTC	8	temperature sensing input
MTV	9	maximum temperature voltage
RFSH	10	refresh input/output
FCT	11	fast charge termination and battery chemistry identification
V <sub>P</sub>	12	positive supply voltage
V <sub>sl</sub>	13	switched reference voltage output
OSC	14	oscillator input
PWM	15	pulse width modulator output
V <sub>S</sub>	16	stabilized reference voltage
LS	17	loop stability pin
AO	18	analog output
V <sub>bat</sub>	19	single-cell battery voltage input
R <sub>ref</sub>	20	reference resistor pin

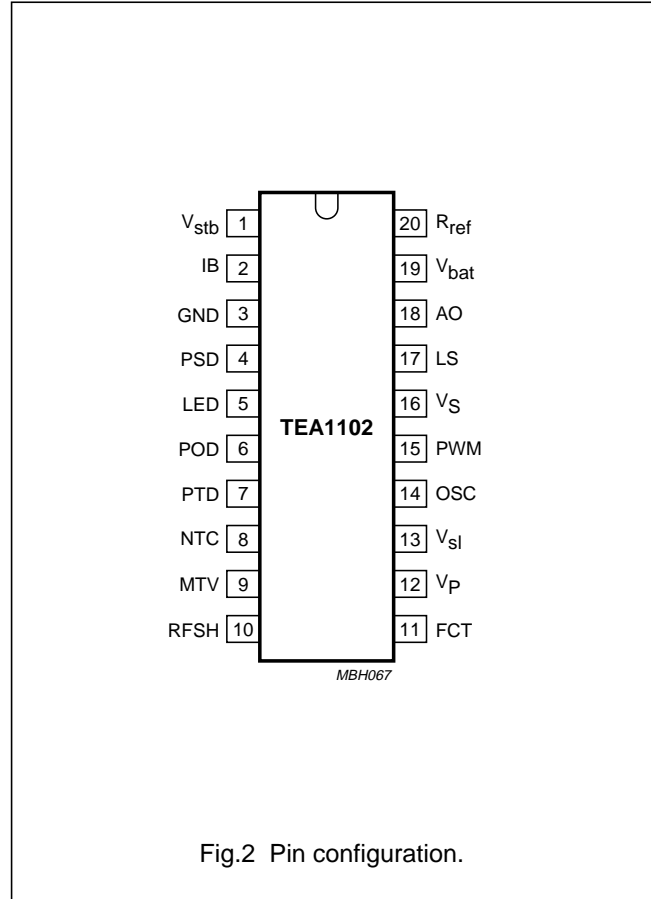

Fig.2 Pin configuration.

## Fast charge ICs for NiCd, NiMH, SLA and Lilon

## TEA1102; TEA1102T; TEA1102TS

### INTRODUCTION

All battery types are initially fast charged with an adjustable high current. Fast charge termination depends upon the battery type. With NiCd and NiMH batteries the main fast charge termination will be the  $\Delta T/\Delta t$  (temperature detection) and/or peak voltage detection and with SLA and Lilon batteries when the battery voltage reaches 2.45 or 4.1 V respectively.

The fast charge period is followed by a top-off period for NiCd and NiMH batteries and by a fill-up period for SLA and Lilon batteries. During the top-off period the NiCd and NiMH batteries are charged to maximum capacity by reduced adjustable charge current.

During the fill-up period the SLA and Lilon batteries are charged to maximum capacity by a constant voltage and a gradually decreasing current. The fill-up and top-off period ends after time-out or one hour respectively.

After the fill-up or top-off period, the TEA1102x switches over to the standby mode. For NiCd and NiMH batteries either the voltage regulation or trickle charge mode can be selected. The voltage regulation mode is selected when the battery includes a fixed load. Trickle charge prevents a discharge of the battery over a long period of time. For SLA and Lilon batteries the charge current is disabled during standby. The fast charge mode is entered again when the battery voltage reaches 1.5 V (SLA) or 3 V (Lilon).

### Charging principles

#### CHARGING NiCd/NiMH BATTERIES

Fast charging of the battery begins when the power supply voltage is applied and at battery insertion.

During fast charge of NiCd and NiMH batteries, the battery temperature and voltage are monitored. Outside the initialized temperature and voltage window, the system switches over to the top-off charge current.

The TEA1102x supports detection of fully charged NiCd and NiMH batteries by either of the following criteria:

- $\Delta T/\Delta t$
- Voltage peak detection.

If the system is programmed with  $\Delta T/\Delta t$  and  $V_{\text{peak}}$  or  $\Delta T/\Delta t$  or  $V_{\text{peak}}$  as the main fast charge termination, it automatically switches to voltage peak detection if the battery pack is not provided with a temperature sensing input (NTC). In this way both packages, with and without temperature sensor, can be used randomly independent of the applied full detection method. Besides  $\Delta T/\Delta t$  and/or

voltage peak detection, fast charging is also protected by temperature cut-off and time-out.

To avoid false fast charge termination by peak voltage detection or  $\Delta T/\Delta t$ , full detection is disabled during a short hold-off period at the start of a fast charge session. After fast charge termination, the battery is extra charged by a top-off period. During this period of approximately one hour, the charge current is lowered thus allowing the battery to be charged to nearly 100% before the system switches over to standby.

After the battery has been charged to nearly 100% by the top-off period, discharge of the battery (caused by a load or by the self-discharge) can be avoided by voltage regulation or by trickle charge.

If batteries are charged in combination with a load, the TEA1102x can be programmed to apply voltage regulation during the standby mode. In this way, discharge of the battery caused by self-discharge or by an eventual load is avoided. The regulating voltage is adjustable to the voltage characteristic of the battery. For battery safety the charge current is limited and the temperature is monitored during voltage regulation. If a trickle charge is applied, the self-discharge of the battery will be compensated by a pulsating charge current.

To avoid the so called 'memory effect' in NiCd batteries, a refresh can be manually activated. The discharge current is regulated by the IC in combination with an external power transistor. After discharging the battery to 1 V per cell, the system automatically switches over to fast charge.

#### CHARGING LiION/SLA BATTERIES

Charging these types of batteries differs considerably from charging NiCd and NiMH batteries. The batteries will be charged with a charge current of 0.15 CA if their cell voltage is below the minimum voltage of 0.9 V for Lilon or 0.45 V for SLA. With batteries in good condition the battery voltage will rise above 0.9 V in a short period of time. When the batteries are short-circuited the voltage will not rise above 0.9 V within one hour and the system will change over to cut-off, which means that the output drivers AO and PWM are fixed to zero and that battery charge can only be started again after a power-on reset. If the battery voltage of a good condition battery is above the minimum level of 0.9 V the battery will be charged with the programmed fast charge current.

If Lilon or SLA batteries are used, 'full' is detected when the battery voltage reaches 4.1 and 2.45 V respectively. At this point the TEA1102x switches from current regulation to voltage regulation (fill-up mode).

## Fast charge ICs for NiCd, NiMH, SLA and Lilon

## TEA1102; TEA1102T; TEA1102TS

After the 'fill-up' period the charge current is not regulated, which means that the output drivers AO and PWM are fixed to zero. When the battery voltage becomes less than 3 V for Lilon and 1.5 V for SLA, the IC enters the fast charge mode again.

### FUNCTIONAL DESCRIPTION

#### Control logic

The main function of the control logic is to support the communication between several blocks. It also controls the charge method, initialization and battery full detection. The block diagram of the TEA1102x is illustrated in Fig.1.

#### Conditioning charge method and initializations

At system switch-on, or at battery insertion, the control logic sets the initialization mode in the timer block. After the initialization time the timer program pins can be used to indicate the charging state using several LEDs. The charge method is defined at the same time by the following methods:

- If the FCT pin is 0 or 1.25 V, indicating that SLA or Lilon batteries have to be charged, the battery will be charged by limit current and limit voltage regulation. Without identification (FCT pin floating), the system will charge the battery according to the charge characteristic of NiCd and NiMH batteries.

- The standby charge method (NiCd and NiMH), trickle charge or voltage regulation, is defined by the input pin  $V_{stb}$ . By biasing this voltage with a set voltage, the output voltage will be regulated to the  $V_{stb}$  set voltage. If this pin is connected to  $V_S$ , or no NTC is connected the system applies trickle charge.

If pin RFSH is connected to ground by depressing the switch, the TEA1102x discharges the battery via an external transistor connected to pin RFSH. The discharge current is regulated with respect to the external (charge) sense resistor ( $R_{sense}$ ). End-of-discharge is reached when the battery is discharged to 1 V per cell. Refreshing the battery can only be activated during charging of NiCd and NiMH batteries. When charging Lilon and SLA batteries, discharge before charge is disabled.

The inhibit mode has the main priority. This mode is activated when the  $V_{stb}$  input pin is connected to ground. Inhibit can be activated at any charge/discharge state, whereby the output control signals will be zero, all LEDs will be disabled and the charger timings will be set on hold. Table 1 gives an operational summary.

**Table 1** Functionality of program pins

FUNCTION	FCT	NTC	RFSH	$V_{stb}$
Inhibit	X <sup>(1)</sup>	X <sup>(1)</sup>	X <sup>(1)</sup>	low
Lilon and SLA detection	low	X <sup>(1)</sup>	X <sup>(1)</sup>	X <sup>(1)</sup>
Refresh (NiCd and NiMH)	not low <sup>(2)</sup>	X <sup>(1)</sup>	low	not low
$\Delta T/\Delta t$ detection	floating	note 3	not low	not low
$\Delta T/\Delta t$ and voltage peak detection	high	note 3	not low	not low
Voltage peak detection	not low	note 4	not low	not low
Trickle charge at standby	not low	X <sup>(1)</sup>	not low	high
	not low	note 4	not low	not low
Voltage regulation at standby	not low	note 3	not low	floating <sup>(5)</sup>

#### Notes

1. Where X = don't care.
2. Not low means floating or high.
3. The NTC voltage has been to be less than 3.3 V, which indicates the presence of an NTC.
4. The NTC voltage is outside the window for NTC detection.
5.  $V_{stb}$  has to be floating or set to a battery regulating voltage in accordance with the specification.

## Fast charge ICs for NiCd, NiMH, SLA and Lilon

## TEA1102; TEA1102T; TEA1102TS

### Supply block

The supply block delivers the following outputs:

- A power-on reset pulse to reset all digital circuitry at battery insertion or supply switch-on. After a general reset the system will start fast charging the battery.
- A 4.25 V stabilized voltage source ( $V_S$ ) is externally available. This source can be used to set the thermistor biasing, to initialize the programs, to supply the external circuitry for battery voltage based charge indication and to supply other external circuitry.
- A 4.25 V bias voltage ( $V_{SI}$ ) is available for use for more indication LEDs. This output pin will be zero during the initialization period at start-up, thus avoiding any interference of the extra LEDs when initializing.

### Charge control

The charge current is sensed via a low-ohmic resistor ( $R_{sense}$ ), see Fig.4. A positive voltage is created across resistor  $R_b$  by means of a current source  $I_{ref}$  which is set by  $R_{ref}$  in the event of fast charge and by an internal bias current source in the event of top-off and trickle charge ( $I_B$ ), see Fig.1. The positive node of  $R_b$  will be regulated to zero via error amplifier A1, which means that the voltage across  $R_b$  and  $R_{sense}$  will be the same. The fast charge current is defined by the following equation:

$$I_{fast} \times R_{sense} = R_b \times I_{ref} \quad (1)$$

The output of amplifier A1 is available at the loop stability pin LS, consequently the time constant of the current loop can be set. When  $V_{peak}$  (NiCd and NiMH) is applied, the current sensing for the battery voltage will be reduced, implying that the charge current will be regulated to zero during:

$$t_{sense} = 2^{10} \times POD \times t_{osc} \quad (2)$$

Actually battery voltage sensing takes place in the last oscillator cycle of this period.

To avoid modulation on the output voltage, the top-off charge current is DC regulated, defined by the following equation:

$$I_{top-off} \times R_{sense} = R_b \times 3 \times 10^{-6} \quad (3)$$

where:

$$t_{top-off} = 2^{27} \times TOD \times t_{osc} \quad (4)$$

The top-off charge current will be approximately 0.15 CA, which maximizes the charge in the battery under safe and slow charging conditions. The top-off charge period will be approximately one hour, so the battery will be extra

charged with approximately 0.15 Q. In this way the battery is fully charged before the system switches over to standby.

When pin 1 ( $V_{stb}$ ) is connected to  $V_S$ , or no NTC is connected the system compensates the (self) discharge of the battery by trickle charge. The trickle charge current will be pulsating, defined by the following equation:

$$I_{trickle} \times R_{sense} = R_b \times \frac{15}{16} \times 10^{-6} \quad (5)$$

During the non current periods at trickle charge the charge current is regulated to zero, so that the current for a load connected in series across the battery with the sense resistor will be supplied by the power supply and not by the battery.

If at pin 1 ( $V_{stb}$ ) a reference voltage is set in accordance with the specification, and no NTC is connected the charge mode will switch over from current to voltage regulation after top-off. The reference regulating voltage can be adjusted to the battery characteristic by external resistors connected to pin  $V_{stb}$ .

This reference voltage has to be selected in such a way that it equals the rest voltage of the battery. By using voltage regulation, the battery will not be discharged at a load occurrence. If the  $V_{stb}$  input pin is floating, the TEA1102x will apply voltage regulation at 1.325 V during the standby mode (NiCd and NiMH). The current during voltage regulation is limited to 0.5 CA. If the battery charge current is maximized to 0.5 CA for more than 2 hours charging will be stopped. Moreover, if the temperature exceeds  $T_{max}$ , charging will be stopped completely. As voltage regulation is referred to one cell, the voltage on the  $V_{bat}$  pin must be the battery voltage divided by the number of cells (NiCd and NiMH).

For Lilon or SLA batteries, the battery is extra charged after full detection by constant voltage regulation during a certain fill-up period. Lilon and SLA batteries have to identify themselves by an extra pin on the battery pack to ground, which is connected via a resistor to pin 11 (FCT). As the battery voltage sense ( $V_{bat}$ ) has to be normalized to a one cell voltage of NiCd and NiMH packages, the  $V_{bat}$  input pin will be regulated to 1.367 and 1.633 V during fill-up for Lilon and SLA respectively. In this way this system can accept a mixture of one Lilon, two SLA and three NiCd or NiMH packages.

After fill-up, charging of Lilon or SLA batteries is disabled. The battery charge is then fixed to zero, ensuring maximum life-cycle of the battery.

Because of a fixed zero charge current, the battery will be discharged if a load is applied.



## Fast charge ICs for NiCd, NiMH, SLA and Lilon

## TEA1102; TEA1102T; TEA1102TS

To ensure an eventual load during all charging states, the fast charge mode will be entered again if the battery voltage drops below 15 V for SLA or 3 V for Lilon.

When charging, the standby mode (Lilon and SLA) can only be entered after a certain period of time depending on time-out. The same applies for charging NiCd or NiMH batteries. To support full test of the TEA1102x at application, the standby mode is also entered when  $V_{bat} < V_{bat(l)}$  at fill-up or top-off respectively.

### Timer

The timing of the circuit is controlled by the oscillator frequency.

The timer block defines the maximum charging time by 'time-out'. At a fixed oscillator frequency, the time-out time can be adapted by the Programmable Time-out Divider (PTD) using the following equation.

$$t_{\text{time-out}} = 2^{26} \times \text{POD} \times \text{PTD} \times t_{\text{osc}} \quad (6)$$

The time-out timer is put on hold by low voltage, temperature protection and during the inhibit mode. The Programmable Oscillator Divider (POD) enables the oscillator frequency to be increased without affecting the sampling time and time-out. Raising the oscillator frequency will reduce the size of the inductive components that are used.

At fast charging, after battery insertion, after refresh or supply interruption, the full detector will be disabled for a period of time to allow a proper start with flat or inverse polarized batteries. This hold-off period is disabled at fast charging by raising pin  $V_{\text{stb}}$  to above  $\pm 5$  V (once). So for test options it is possible to slip the hold-off period. The hold-off time is defined by the following equation:

$$t_{\text{hold-off}} = 2^{-5} \times t_{\text{time-out}} \quad (7)$$

Table 2 gives an overview of the settings of timing and discharge/charge currents.

**Table 2** Timing and current formulae

SYMBOL	DESCRIPTION	FORMULAE
$t_{\text{osc}}$	timing	see Fig.3
$T_{\text{sampling}} (\Delta T/\Delta t)$	NTC voltage sampling frequency	$2^{17} \times \text{POD} \times \text{PSD} \times t_{\text{osc}}$
$T_{\text{sampling}} (V_{\text{peak}})$	battery voltage sampling frequency	$2^{16} \times \text{POD} \times t_{\text{osc}}$
$t_{\text{top-off}}$		$2^{27} \times \text{POD} \times t_{\text{osc}}$
$t_{\text{time-out}}$		$2^{26} \times \text{POD} \times \text{PTD} \times t_{\text{osc}}$
$t_{\text{hold-off}}$		$2^{-5} \times t_{\text{time-out}}$
$t_{\text{LED}}$	inhibit or protection	$2^{14} \times \text{POD} \times t_{\text{osc}}$
$t_{\text{sense}}$		$2^{10} \times \text{POD} \times t_{\text{osc}}$
$t_{\text{switch}}$		$2^{21} \times \text{POD} \times \text{PTD} \times t_{\text{osc}}$
$I_{\text{fast}}$	charge/discharge currents	$\frac{R_b}{R_{\text{sense}}} \times \frac{V_{\text{ref}}}{R_{\text{ref}}}$
$I_{\text{top-off}}$		$\frac{R_b}{R_{\text{sense}}} \times 3 \times 10^{-6}$
$I_{\text{trickle}}$		$\frac{R_b}{R_{\text{sense}}} \times \frac{15}{16} \times 10^{-6}$
$I_{\text{load-max}}$		$\frac{R_b}{R_{\text{sense}}} \times 40 \times 10^{-6}$
$I_{\text{RFSH}}$		$\frac{100 \text{ mV}}{R_{\text{sense}}}$

Fast charge ICs for NiCd, NiMH, SLA and Lilon

TEA1102; TEA1102T; TEA1102TS

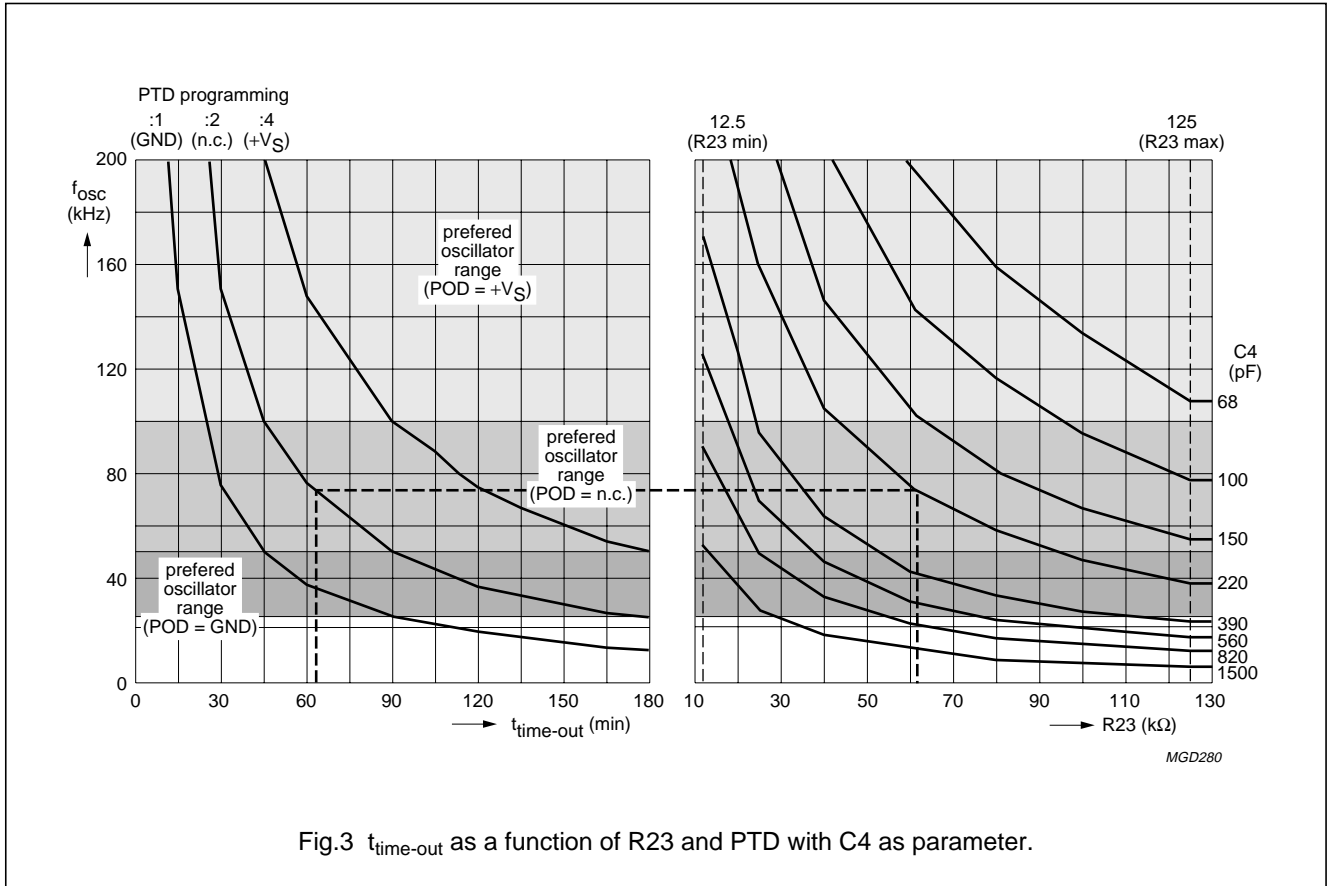

**LED indication**

With few external components, indication LEDs can be connected to the program pins and the LED pin of the TEA1102x. These program pins change their function from an input to an output pin after a short initialization time at system switch-on or battery insertion. Output pin V<sub>sl</sub> enables the external LEDs to be driven and avoids interaction with the programming of the dividers during the initialization period.

The applied LEDs indicate:

- Protection
- Refresh
- Fast charge
- 100%
- No-battery.

The LED output pin can also indicate the charging state by one single LED. The indication LED can be connected directly to the LED output. This single LED indicates:

- Fast charge (LED on)
- 100% or refresh (LED off)
- Protection or inhibit (LED floating).

The refresh can be indicated by an extra LED connected to pin 4 (PSD). A buzzer can also be driven from the TEA1102x to indicate battery insertion end of refresh or full battery.

**AD/DA converter**

When battery full is determined by peak voltage detection, the V<sub>bat</sub> voltage is sampled at a rate given by the following equation:

$$t_{\text{sampling}}(V_{\text{peak}}) = 2^{16} \times \text{POD} \times t_{\text{osc}} \tag{8}$$

The analog value of a V<sub>bat</sub> sample is then digitized and stored in a register. On the following sample, the digitized value is converted back to the analog value of V<sub>bat</sub> and compared with the 'new' V<sub>bat</sub> sample.

## Fast charge ICs for NiCd, NiMH, SLA and Lilon

## TEA1102; TEA1102T; TEA1102TS

At an increase of the battery voltage the 14-bit analog-to-digital convertor (ADC) is refreshed with this new value. Therefore, the digitized value always represents the maximum battery voltage. A decreased  $V_{\text{bat}}$  voltage is not stored, but is compared to the stored value.

Full is detected when the voltage decrease of  $V_{\text{bat}}$  is  $\frac{1}{4}\%$  of the stored peak battery value. To avoid interference due to the resistance of the battery contacts during battery voltage sensing, the charge current is regulated to zero during  $t = 2^{10} \times \text{POD} \times t_{\text{osc}}$ , via the regulation pins AO and PWM. At the last period, the  $V_{\text{bat}}$  voltage is sensed and stored in a sample-and-hold circuit. This approach ensures very accurate detection of the battery full condition (minus  $\frac{1}{4}\%$ ).

When battery full is determined by  $\Delta T/\Delta t$ , the voltage on the NTC pin is used as the input voltage to the AD/DA convertor. The sampling time at  $\Delta T/\Delta t$  sensing is given by the following equation:

$$t_{\text{sampling}}\left(\frac{\Delta T}{\Delta t}\right) = 2^{17} \times \text{POD} \times \text{PSD} \times t_{\text{osc}} \quad (9)$$

After this initialized sample time the new temperature voltage is compared to the preceding AD/DA voltage and the AD/DA is refreshed with this new value. A certain increase of the temperature is detected as full battery, depending on the initialization settings. The decision of full detection by  $\Delta T/\Delta t$  or  $V_{\text{peak}}$  is digitally filtered thus avoiding false battery full detection.

### Output drivers

The charge current regulation signal is available at two output pins, AO and PWM.

#### ANALOG OUTPUT

The analog control voltage output at pin 18 (AO) can be used to drive an opto-coupler in mains separated applications when an external resistor is connected between AO and the opto-coupler. The maximum current through the opto-coupler diode is 2 mA. The voltage gain of amplifier A2 is typical 11 dB (times 3.5). The DC voltage transfer is given by the following equation:

$$V_{\text{ao}} = 3.5 \times (V_{\text{LS}} - 1.35).$$

The AO output can be used for:

- Linear (DC) applications
- Not mains isolated SMPS with a separate controller
- Mains isolated SMPS, controlled by an opto-coupler.

#### PULSE WIDTH MODULATOR (PWM)

The LS voltage is compared internally with the oscillator voltage to deliver a pulse width modulated output at PWM (pin 15) to drive an output switching device in a SMPS converter application via a driver stage. The PWM output is latched to prevent multi-pulsing. The maximum duty factor is internally fixed to 79% (typ.). The PWM output can be used for synchronization and duty factor control of a primary SMPS via a pulse transformer.

# Fast charge ICs for NiCd, NiMH, SLA and Lilon

# TEA1102; TEA1102T; TEA1102TS

## LIMITING VALUES

In accordance with the Absolute Maximum Rating System (IEC 134); note 1.

SYMBOL	PARAMETER	CONDITIONS	MIN.	TYP.	MAX.	UNIT
<b>Voltages</b>						
$V_P$	positive supply voltage		-0.5	-	11.5	V
$V_{oLED}$	output voltage at pin 5		-0.5	-	15	V
$V_n$	voltage at pins PWM, LS and NTC		-0.5	-	+ $V_S$	V
$V_{IB}$	voltage at pin 2		-0.5	-	1.0	V
<b>Currents</b>						
$I_{VS}$	current at pin 16		-3	-	+0.01	mA
$I_{Vsl}$	current at pin 13		-1	-	+0.3	mA
$I_{oLED}$	output current at pin 5		-	-	12	mA
$I_{AO}$	output current at pin 18		-10	-	+0.05	mA
$I_{oPWM}$	output current at pin 15		-15	-	+14	mA
$I_{Rref}$	current at pin 20		-1	-	+0.01	mA
$I_P$	positive supply current	$T_j < 100\text{ °C}$	-	-	30	mA
$I_{P(stb)}$	supply standby current	$V_P = 4\text{ V}$	-	35	45	$\mu\text{A}$
<b>Dissipation</b>						
$P_{tot}$	total power dissipation	$T_{amb} = +85\text{ °C}$				
	SOT146-1		-	-	1.2	W
	SOT163-1		-	-	0.6	W
	SOT339-1		-	-	0.45	W
<b>Temperatures</b>						
$T_{amb}$	operating ambient temperature		-20	-	+85	$^{\circ}\text{C}$
$T_j$	junction temperature		-	-	+150	$^{\circ}\text{C}$
$T_{stg}$	storage temperature		-55	-	+150	$^{\circ}\text{C}$

## Note

- All voltages are measured with respect to ground; positive currents flow into the IC; all pins not mentioned in the voltage list are not allowed to be voltage driven. The voltage ratings are valid provided that other ratings are not violated; current ratings are valid provided that the power rating is not violated.

## QUALITY SPECIFICATION

General quality specification for integrated circuits: SNW-FQ-611E.

## Fast charge ICs for NiCd, NiMH, SLA and Lilon

TEA1102; TEA1102T;  
TEA1102TS**CHARACTERISTICS**

$V_P = 10\text{ V}$ ;  $T_{\text{amb}} = 25\text{ °C}$ ;  $R_{\text{ref}} = 62\text{ k}\Omega$ ; unless otherwise specified.

SYMBOL	PARAMETER	CONDITIONS	MIN.	TYP.	MAX.	UNIT
<b>Supplies; pins <math>V_P</math>, <math>V_S</math>, <math>R_{\text{ref}}</math> and <math>V_{\text{sl}}</math></b>						
$V_P$	supply voltage		5.5	–	11.5	V
$I_P$	supply current	outputs off; $V_P = 11.5\text{ V}$	–	4	6	mA
$I_{\text{stb}}$	standby current	$V_P = 4\text{ V}$	–	35	45	$\mu\text{A}$
$V_{\text{clamp}}$	clamping voltage (pin 12)	$I_{\text{clamp}} = 30\text{ mA}$	11.5	–	12.8	V
$V_{\text{start}}$	start voltage		6.1	6.4	6.7	V
$V_{\text{LSP}}$	low supply protection level		5.1	5.3	5.5	V
$V_S$	source voltage (stabilized)	$I_S = 2\text{ mA}$	4.14	4.25	4.36	V
$V_{\text{SL}}$	LED source voltage	$I_{\text{LED}} = 50\text{ }\mu\text{A}$	4.05	4.25	4.45	V
$V_{\text{ref}}$	reference voltage	$I_{\text{ref}} = 20\text{ }\mu\text{A}$ ; $V_P = 10\text{ V}$	1.21	1.25	1.29	V
$\text{TC}_{V_{\text{ref}}}$	temperature coefficient of the reference voltage	$T_{\text{amb}} = 0\text{ to }45\text{ °C}$ ; $I_{\text{ref}} = 20\text{ }\mu\text{A}$ ; $V_{\text{ref}} = 1.25\text{ V}$	0	$\pm 60$	$\pm 120$	ppm/K
$\Delta V_{\text{ref}}/\Delta V_P$	power supply rejection ratio of the reference voltage	$f = 100\text{ Hz}$ ; $V_P = 8\text{ V}$ ; $\Delta V_P = 2\text{ V (p-p)}$	–46	–	–	dB
$\Delta V_{\text{ref}}$	load rejection of source voltage	$\Delta I_S = 20\text{ mA}$ ; $V_P = 10\text{ V}$	–	–	5	mV
$I_{\text{Rref}}$	current range of reference resistor		10	–	100	$\mu\text{A}$
<b>Charge current regulation; pins IB and <math>R_{\text{ref}}</math></b>						
$I_{\text{B}}/I_{\text{ref}}$	fast charge ratio	$V_{\text{IB}} = 0$ $I_{\text{ref}} = 10\text{ }\mu\text{A}$ $I_{\text{ref}} = 100\text{ }\mu\text{A}$	0.93 0.93	1.03 1.0	1.13 1.07	
$V_{\text{thIB}}$	threshold voltage at pin IB	$T_{\text{amb}} = 25\text{ °C}$	–2	–	+2	mV
		$T_{\text{amb}} = 0\text{ to }45\text{ °C}$	–3	–	+3	mV
$I_{\text{IB}}$	charge current	top-off mode; $V_{\text{IB}} = 0$	2.6	3.2	3.8	$\mu\text{A}$
$I_{\text{B(max)}}$	maximum charge current	voltage regulation full NiCd/NiMH battery; $V_{\text{IB}} = 0$	9	10.5	12	$\mu\text{A}$
$I_{\text{B(Lmax)}}$	maximum load current	open battery; $V_{\text{IB}} = 0$	34	42	50	$\mu\text{A}$
$I_{\text{B(LI)}}$	input leakage current	currentless mode	–	–	170	nA
<b>Refresh; pin RFSH</b>						
$V_{\text{Rsense}}$	sense resistor voltage	$I_{\text{refresh}} = V_{\text{IB}}/R_{\text{sense}}$ ; refresh mode; $I_{\text{refresh}} = 18\text{ mA}$	75	100	125	mV
$V_{\text{RFSH}}$	refresh voltage for programming start of refresh	NiCd/NiMH	0	–	250	mV
$V_{\text{bat}}$	voltage at pin $V_{\text{bat}}$ for detecting end of refresh	NiCd/NiMH	0.96	1.0	1.04	V
$I_{\text{source(max)}}$	maximum source current	$V_{\text{IB}} = 75\text{ mV}$ ; $V_P = 10\text{ V}$ ; $V_{\text{RFSH}} = 2.7\text{ V}$ ; $T_{\text{amb}} = 25\text{ °C}$	1.4	2	2.6	mA

Fast charge ICs for NiCd, NiMH, SLA and  
LilonTEA1102; TEA1102T;  
TEA1102TS

SYMBOL	PARAMETER	CONDITIONS	MIN.	TYP.	MAX.	UNIT
$V_{RFSH(max)}$	maximum refresh voltage	$I_{RFSH} = 1 \text{ mA}$	2.7	–	–	V
$V_{RFSH(off)}$	voltage at pin RFSH when refresh is off		700	770	840	mV
<b>Temperature related inputs; pins NTC and MTV</b>						
$V_{NTCh}$	input voltage at pin NTC for detecting high temperature	pin MTV open-circuit	0.9	1	1.1	V
		MTV setting	0.95MTV	MTV	1.05MTV	V
$V_{NTCh(hy)}$	hysteresis of $V_{NTCh}$		–	80	–	mV
$V_{NTCl}$	input voltage at pin NTC, detecting low temperature		2.7	2.8	2.9	V
$V_{NTCl(hy)}$	hysteresis of $V_{NTCl}$		–	75	–	mV
$V_{NTC(co)}$	input voltage at pin NTC for detecting temperature cut-off		0.7MTV	0.75MTV	0.8MTV	V
$V_{NTC(bat)}$	maximum input voltage at pin NTC for detecting battery with NTC		3.22	3.3	3.38	V
$I_{NTC}$	input current at pin NTC	$V_{NTC} = 2 \text{ V}$	–5	–	+5	$\mu\text{A}$
$V_{MTV}$	voltage level at pin MTV	default (open-circuit)	0.95	1	1.05	V
			0.5	–	2.5	V
$\Delta V_{NTC}/V_{NTC}$	$\Delta T/\Delta t$ detection level	$V_{NTC} = 2 \text{ V}; T_j = 0 \text{ to } 50 \text{ }^\circ\text{C}$	–	–0.25	–	%
<b>Voltage regulation</b>						
$V_{reg}$	regulation voltage	Lilon; $I_{ref} = 20 \mu\text{A}$	1.34	1.37	1.40	V
		SLA; $I_{ref} = 20 \mu\text{A}$	1.59	1.63	1.67	V
		NiCd and NiMH; pin $V_{stb}$ open-circuit	1.30	1.325	1.35	V
		NiCd and NiMH; $V_{stb} = 1.5 \text{ V}$	$0.99V_{stb}$	$V_{stb}$	$1.01V_{stb}$	V
		open battery	1.86	1.9	1.94	V
$TC_{Vreg}$	temperature coefficient of regulation voltage	$V_{reg} = 1.37 \text{ V}; T_{amb} = 0 \text{ to } 45 \text{ }^\circ\text{C}$	0	$\pm 60$	$\pm 120$	ppm/K
$g_m$	transconductance of amplifier A3	$V_{bat} = 1.9 \text{ V};$ no battery mode	–	2.0	–	$\text{mA/V}$
<b>Program pin <math>V_{stb}</math></b>						
$V_{stb}$	open voltage at pin $V_{stb}$		1.30	1.325	1.35	V
$V_{stb(im)}$	voltage at pin $V_{stb}$ for programming inhibit mode		0	–	0.8	V
$V_{stb(st)}$	voltage at pin $V_{stb}$ for programming voltage regulation at standby	NiCd and NiMH	1.0	–	2.2	V
$V_{stb(tc)}$	voltage at pin $V_{stb}$ for programming trickle charge at standby	NiCd and NiMH	2.6	–	$V_S$	V

Fast charge ICs for NiCd, NiMH, SLA and  
LilonTEA1102; TEA1102T;  
TEA1102TS

SYMBOL	PARAMETER	CONDITIONS	MIN.	TYP.	MAX.	UNIT
<b>Program pins; PSD, POD and PTD</b>						
V <sub>4,6,7</sub>	voltage level at pins PSD, POD or PTD	default (open-circuit)	1.9	2.1	2.3	V
V <sub>4,6,7(1)</sub>	voltage level at pins PSD, POD or PTD for programming the divider = 1		0	–	1.2	V
V <sub>4,6,7(2)</sub>	voltage level at pins PSD, POD or PTD for programming the divider = 2		1.6	–	2.5	V
V <sub>4,6,7(4)</sub>	voltage level at pins PSD, POD or PTD for programming the divider = 4		3.1	–	V <sub>S</sub>	V
I <sub>PODsink</sub>	protection current for multi-LED indication	V <sub>POD</sub> = 1.5 V	8	10	12	mA
I <sub>PTDsink</sub>	full battery current for multi-LED indication	V <sub>PTD</sub> = 1.5 V	8	10	12	mA
I <sub>PSDsink</sub>	refresh current for multi-LED indication	V <sub>PSD</sub> = 1.5 V	8	10	12	mA
I <sub>LI</sub>	input leakage current	V <sub>POD</sub> = 4.25 V; V <sub>PTD</sub> = 4.25 V; V <sub>PSD</sub> = 4.25 V	0	–	50	μA
<b>Program pin FCT</b>						
V <sub>FCT(SLA)</sub>	voltage level for detecting an SLA battery		0	–	0.7	V
V <sub>FCT(Lilon)</sub>	voltage level for detecting a Lilon battery		0.9	–	1.6	V
V <sub>FCT(or)</sub>	voltage level for programming ΔT/Δt or V <sub>peak</sub> as fast charge termination	NiCd and NiMH	2.0	–	3.3	V
V <sub>FCT(and)</sub>	voltage level for programming ΔT/Δt and V <sub>peak</sub> as fast charge termination	NiCd and NiMH	3.7	–	V <sub>S</sub>	V
V <sub>FCT</sub>	voltage level at pin FCT	default (open-circuit)	2.3	2.6	2.9	V
<b>Program pin LED</b>						
V <sub>LED(m)</sub>	output voltage level for programming multi-LED indication		0	–	2.5	V
V <sub>LED(s)</sub>	output voltage level for programming single LED indication		3.1	–	V <sub>P</sub>	V
I <sub>sink(max)</sub>	maximum sink current	V <sub>LED</sub> = 1.5 V	8	10	12	mA
I <sub>LI(LED)</sub>	input leakage current	V <sub>LED</sub> = 10 V	0	–	70	μA
		V <sub>LED</sub> = 0.6 V	0	–	5	μA
V <sub>O(max)</sub>	maximum output voltage		–	–	15	V

Fast charge ICs for NiCd, NiMH, SLA and  
LilonTEA1102; TEA1102T;  
TEA1102TS

SYMBOL	PARAMETER	CONDITIONS	MIN.	TYP.	MAX.	UNIT
<b>Output drivers; AO, LS and PWM</b>						
$I_{AO(source)}$	analog output source current	$V_{AO} = 3\text{ V (p-p)}$ ; $V_{LS} = 2.8\text{ V}$	-9	-	0	mA
$I_{AO(sink)}$	analog output sink current	$V_{AO} = 3\text{ V (p-p)}$ ; $V_{LS} = 1.2\text{ V}$	50	-	-	$\mu\text{A}$
$g_{m1}$	transconductance of amplifier A1	$V_{IB} = 50\text{ mV}$	-	250	-	$\mu\text{A/V}$
$G_{v1,2}$	voltage gain of amplifiers A1 and A2	$V_{AO} = 3\text{ V (p-p)}$	-	72	-	dB
$G_{v2}$	voltage gain of amplifier A2	$V_{AO} = 2\text{ V (p-p)}$	-	11	-	dB
$I_{LS(source)}$	maximum source current (pin LS)	$V_{LS} = 2.25\text{ V}$	-25	-21	-16	$\mu\text{A}$
$I_{LS(sink)}$	maximum sink current (pin LS)	$V_{LS} = 2.25\text{ V}$	16	21	25	$\mu\text{A}$
$I_{OH(PWM)}$	HIGH level output current	$V_{PWM} = 3\text{ V}$	-19	-15	-11	mA
$I_{OL(PWM)}$	LOW level output current	$V_{PWM} = 0.7\text{ V}$	10	14	18	mA
$\delta_{PWM}$	maximum duty factor		-	79	-	%
<b>Battery monitor; <math>V_{bat}</math></b>						
$I_{V_{bat}}$	battery monitor input current	$V_{bat} = 1.85\text{ V}$	-	1	-	nA
$V_{bat}$	voltage range of $V_{peak}$ detection		0.3	-	2	V
$\Delta V_{bat}/V_{bat}$	$V_{peak}$ detection level with respect to top level	$V_{bat} = 1.85\text{ V}$ ; $T_j = 0\text{ to }50\text{ }^\circ\text{C}$	-	-0.25	-	%
$\Delta V_{bat}$	voltage resolution for $V_{peak}$		-	0.6	-	mV
<b>Protections; <math>V_{bat}</math></b>						
$V_{bat(l)}$	maximum voltage at pin $V_{bat}$ for detecting low battery voltage		0.25	0.30	0.35	V
<b>Oscillator; pin OSC</b>						
$V_{osc(H)}$	HIGH level oscillator switching voltage		-	2.5	-	V
$V_{osc(L)}$	LOW level oscillator switching voltage		-	1.5	-	V
$f_{osc(min)}$	minimum oscillator frequency	$R_{ref} = 125\text{ k}\Omega$ ; $C_{osc} = 400\text{ pF}$	20.9	23	25.1	kHz
$f_{osc(max)}$	maximum oscillator frequency	$R_{ref} = 12.5\text{ k}\Omega$ ; $C_{osc} = 400\text{ pF}$	158	174	190	kHz



Fast charge ICs for NiCd, NiMH, SLA and Lilon

TEA1102, TEA1102T, TEA1102TS

APPLICATION INFORMATION

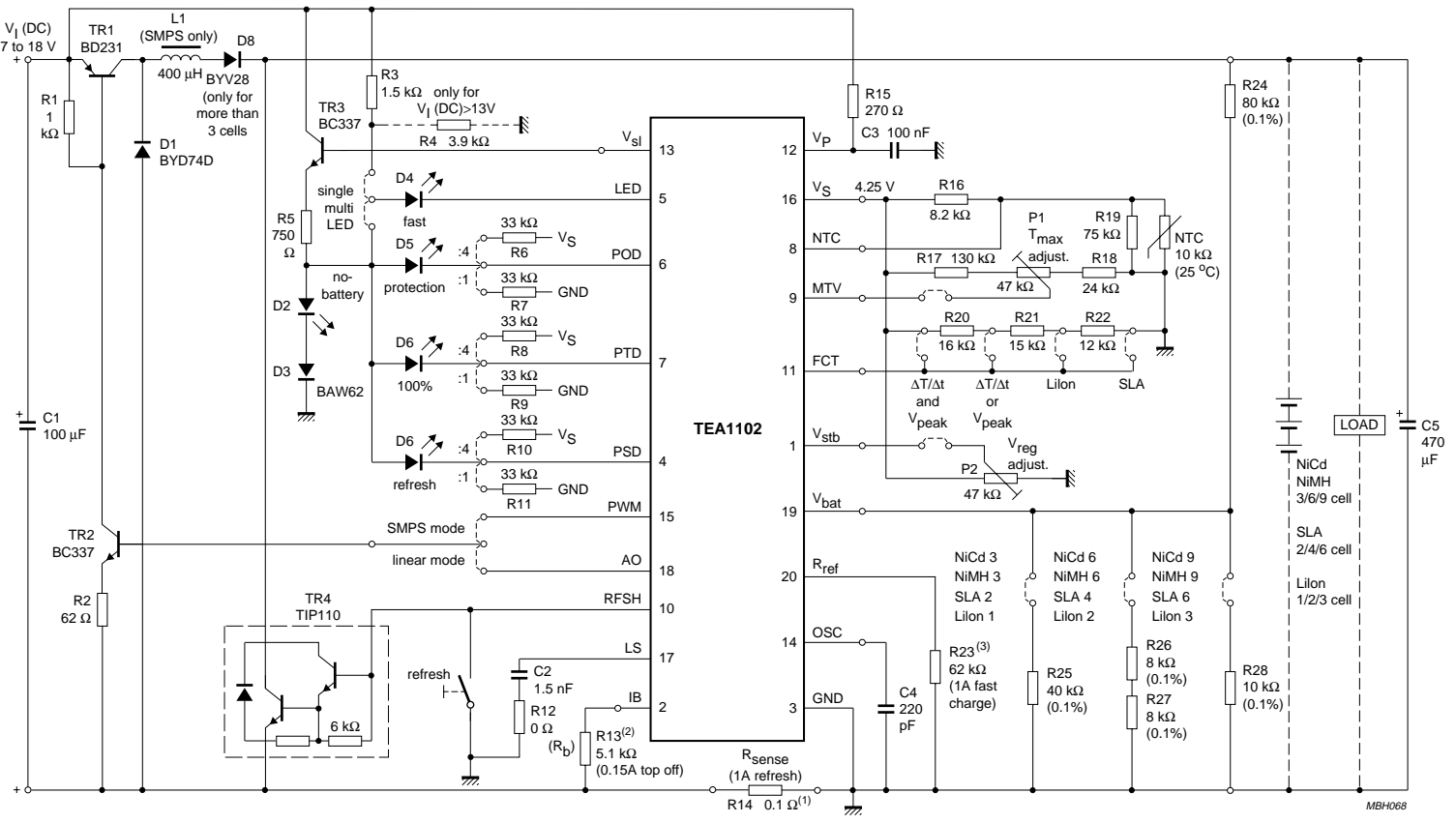

- (1)  $R_{14} = \frac{100 \text{ mV}}{I_{\text{refresh}}}$  or  $R_{14} = \frac{100 \text{ mV}}{I_{\text{fast-charge}}}$  if not applicable.
- (2)  $R_{13} = \frac{R_{14} \times I_{\text{top-off}}}{3 \mu\text{A}}$
- (3)  $R_{23} = \frac{1.25 \times R_{13}}{R_{14} \times I_{\text{fast-charge}}}$

Fig.4 Basic test board diagram.

Fast charge ICs for NiCd, NiMH, SLA and Lilon

TEA1102; TEA1102T;  
TEA1102TS

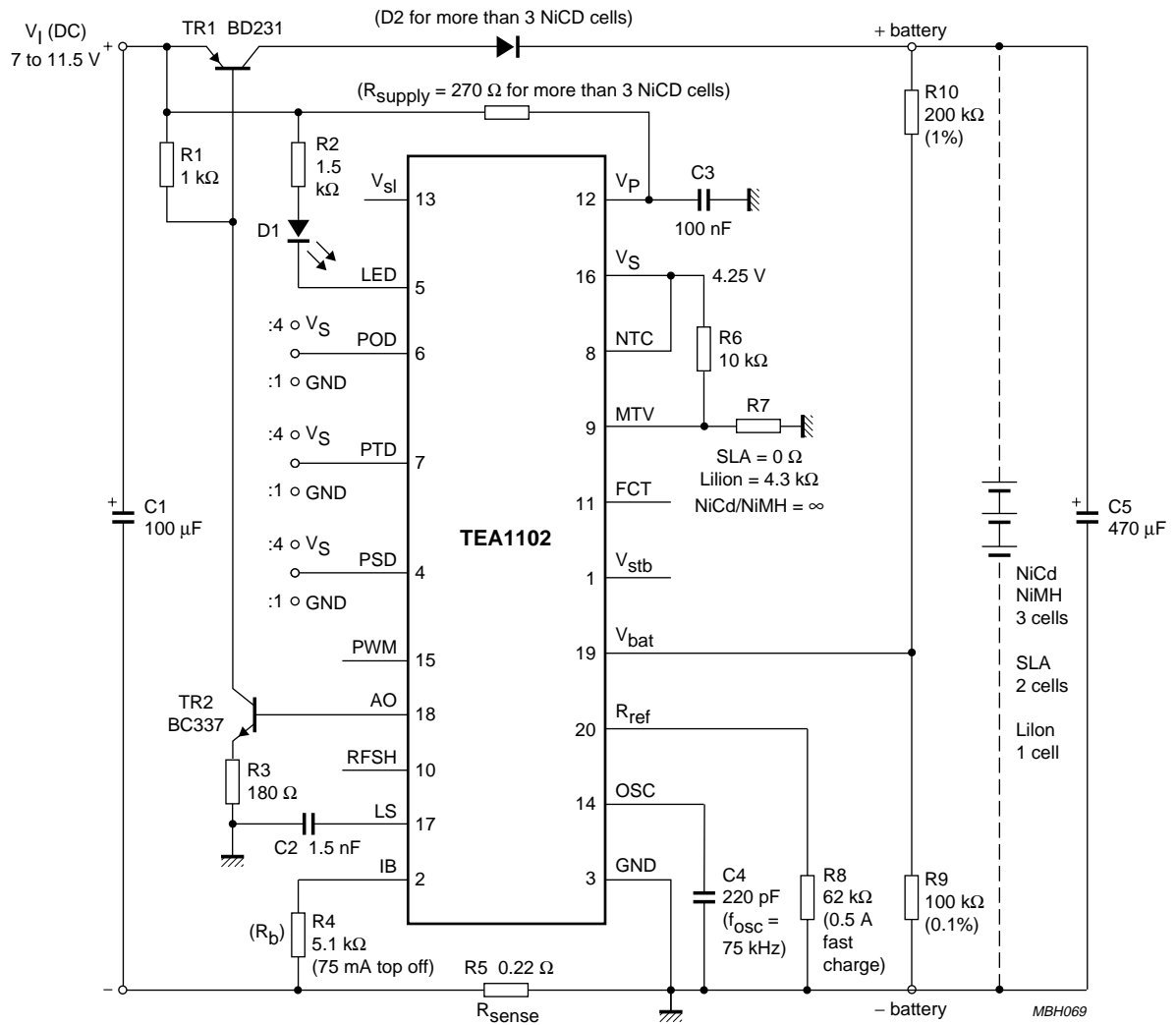
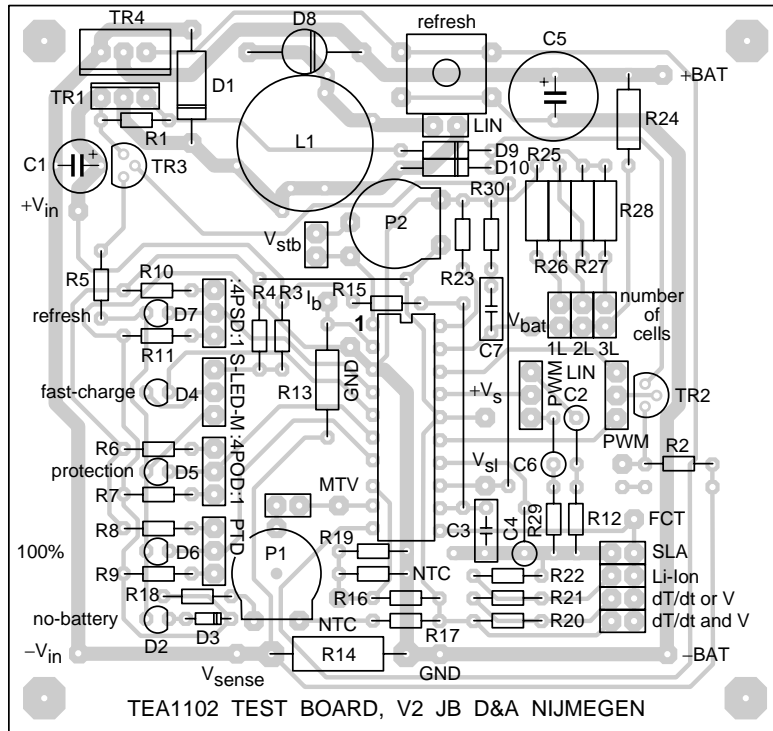

Fig.5 Linear application diagram.

Fast charge ICs for NiCd, NiMH, SLA and Lilon

TEA1102; TEA1102T; TEA1102TS



MBH073

Fig.6 Component side of printed-circuit board (test board).

Fast charge ICs for NiCd, NiMH, SLA and Lilon

TEA1102; TEA1102T;  
TEA1102TS

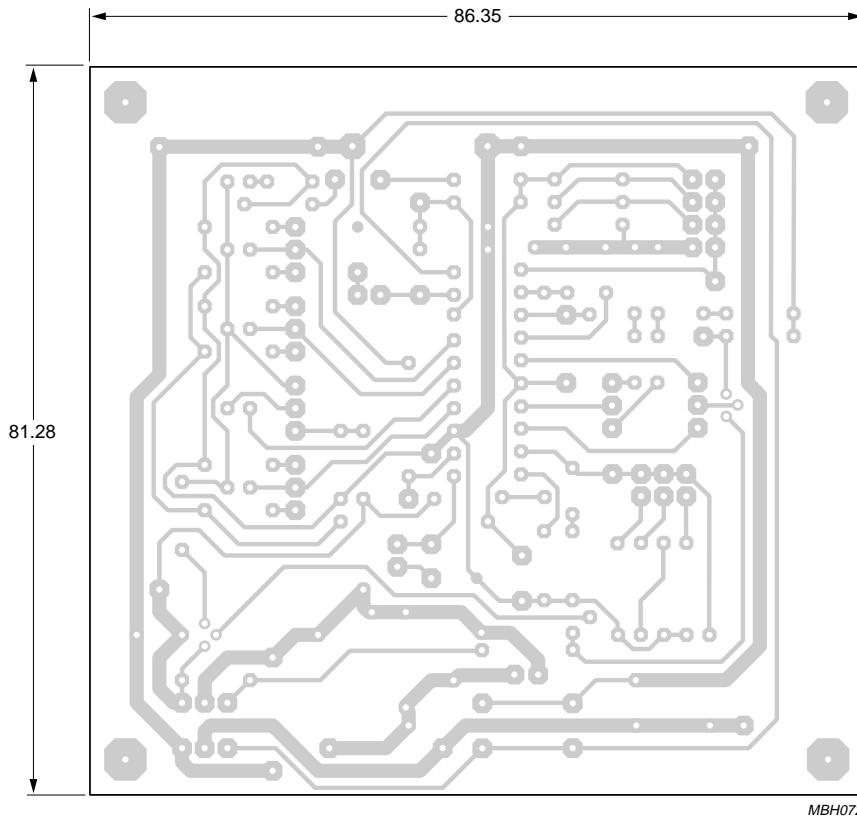

MBH072

Dimensions in mm.

Fig.7 Track side of printed-circuit board (test board).

Fast charge ICs for NiCd, NiMH, SLA and Lilon

TEA1102; TEA1102T;  
TEA1102TS

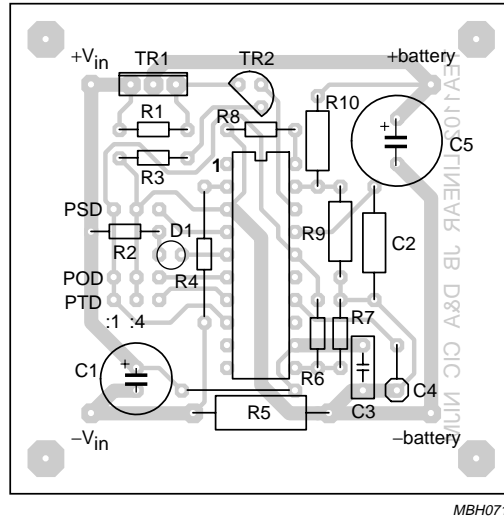

Fig.8 Component side of printed-circuit board (linear application) scale 1 : 1.

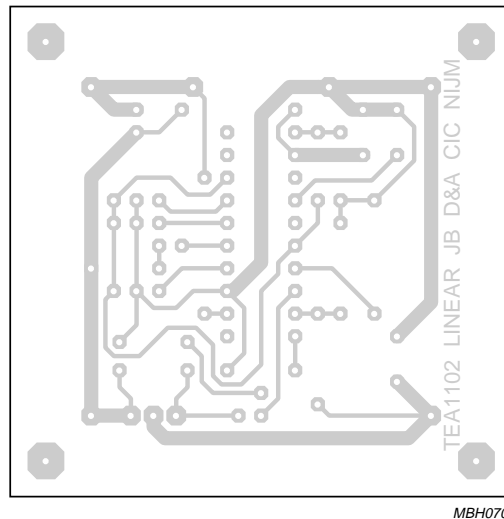

Fig.9 Track side of printed-circuit board (linear application) scale 1 : 1.

Fast charge ICs for NiCd, NiMH, SLA and Lilon

TEA1102; TEA1102T;  
TEA1102TS

PACKAGE OUTLINES

DIP20: plastic dual in-line package; 20 leads (300 mil)

SOT146-1

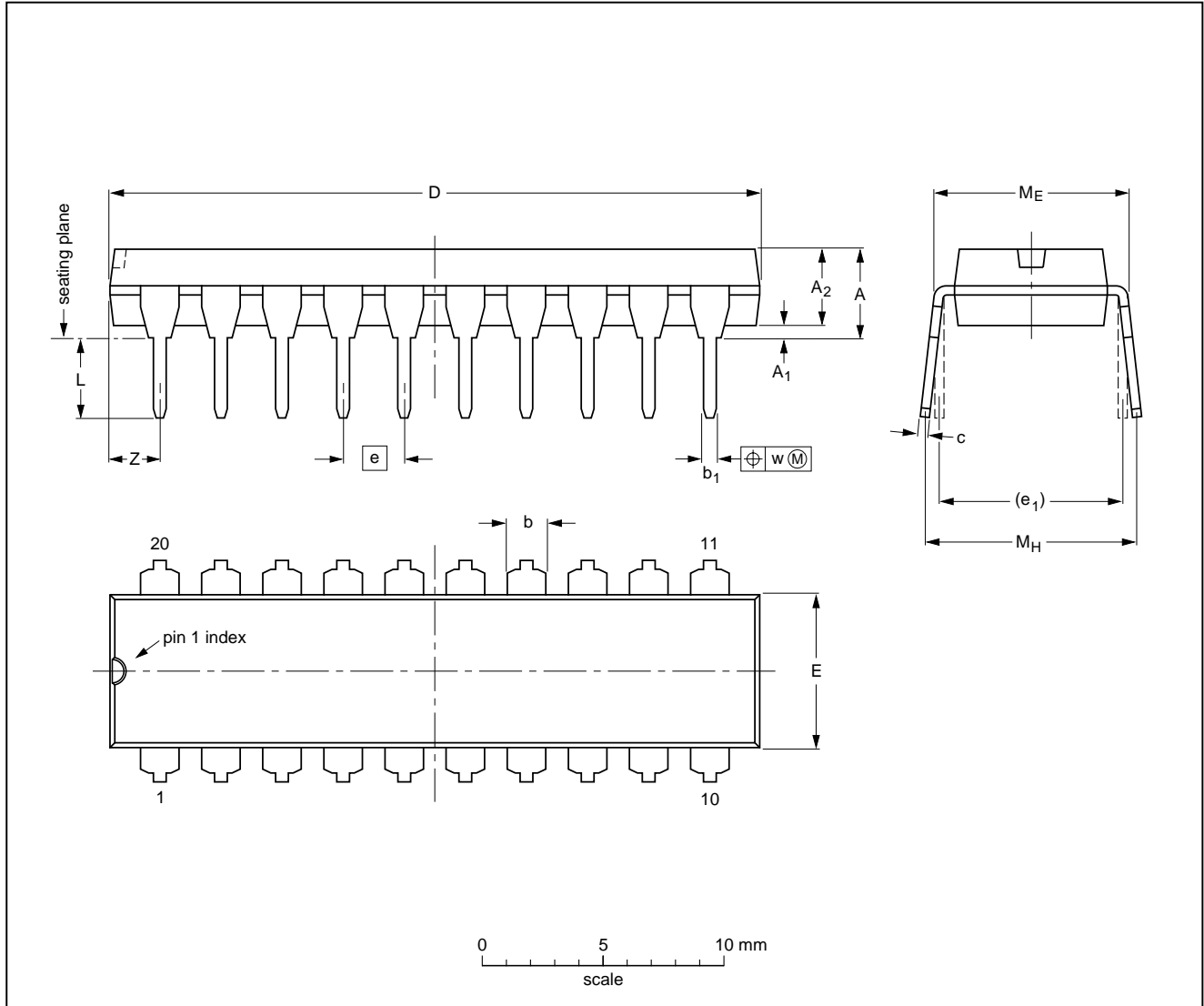

DIMENSIONS (inch dimensions are derived from the original mm dimensions)

UNIT	A max.	A <sub>1</sub> min.	A <sub>2</sub> max.	b	b <sub>1</sub>	c	D <sup>(1)</sup>	E <sup>(1)</sup>	e	e <sub>1</sub>	L	M <sub>E</sub>	M <sub>H</sub>	w	Z <sup>(1)</sup> max.
mm	4.2	0.51	3.2	1.73 1.30	0.53 0.38	0.36 0.23	26.92 26.54	6.40 6.22	2.54	7.62	3.60 3.05	8.25 7.80	10.0 8.3	0.254	2.0
inches	0.17	0.020	0.13	0.068 0.051	0.021 0.015	0.014 0.009	1.060 1.045	0.25 0.24	0.10	0.30	0.14 0.12	0.32 0.31	0.39 0.33	0.01	0.078

Note

1. Plastic or metal protrusions of 0.25 mm maximum per side are not included.

OUTLINE VERSION	REFERENCES				EUROPEAN PROJECTION	ISSUE DATE
	IEC	JEDEC	EIAJ			
SOT146-1			SC603			92-11-17 95-05-24

Fast charge ICs for NiCd, NiMH, SLA and Lilon

TEA1102; TEA1102T;  
TEA1102TS

SO20: plastic small outline package; 20 leads; body width 7.5 mm

SOT163-1

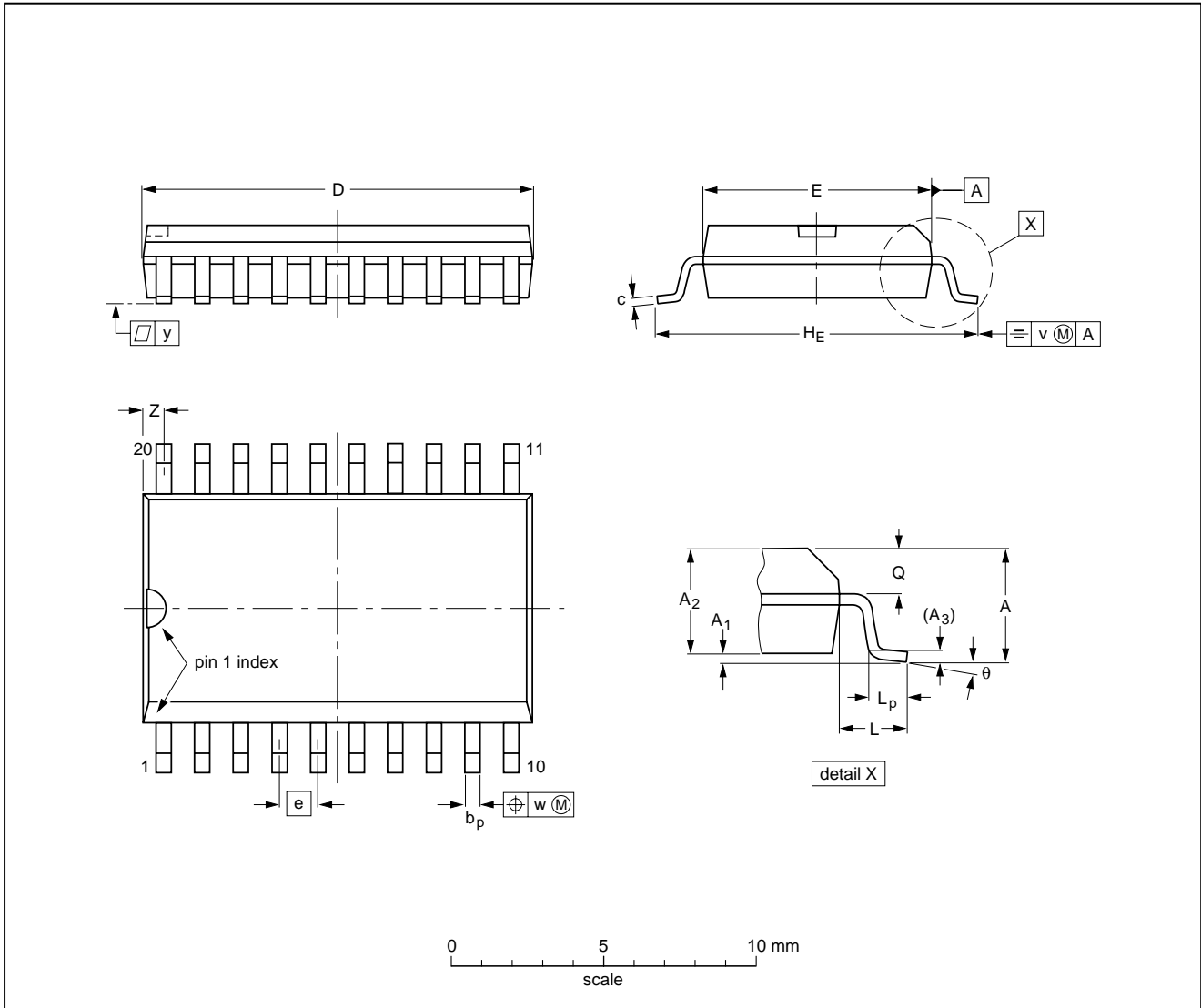

**DIMENSIONS (inch dimensions are derived from the original mm dimensions)**

UNIT	A max.	A <sub>1</sub>	A <sub>2</sub>	A <sub>3</sub>	b <sub>p</sub>	c	D <sup>(1)</sup>	E <sup>(1)</sup>	e	H <sub>E</sub>	L	L <sub>p</sub>	Q	v	w	y	Z <sup>(1)</sup>	θ
mm	2.65	0.30 0.10	2.45 2.25	0.25	0.49 0.36	0.32 0.23	13.0 12.6	7.6 7.4	1.27	10.65 10.00	1.4	1.1 0.4	1.1 1.0	0.25	0.25	0.1	0.9 0.4	8° 0°
inches	0.10	0.012 0.004	0.096 0.089	0.01	0.019 0.014	0.013 0.009	0.51 0.49	0.30 0.29	0.050	0.419 0.394	0.055	0.043 0.016	0.043 0.039	0.01	0.01	0.004	0.035 0.016	

**Note**

1. Plastic or metal protrusions of 0.15 mm maximum per side are not included.

OUTLINE VERSION	REFERENCES				EUROPEAN PROJECTION	ISSUE DATE
	IEC	JEDEC	EIAJ			
SOT163-1	075E04	MS-013AC				95-01-24 97-05-22

Fast charge ICs for NiCd, NiMH, SLA and Lilon

TEA1102; TEA1102T;  
TEA1102TS

SSOP20: plastic shrink small outline package; 20 leads; body width 5.3 mm

SOT339-1

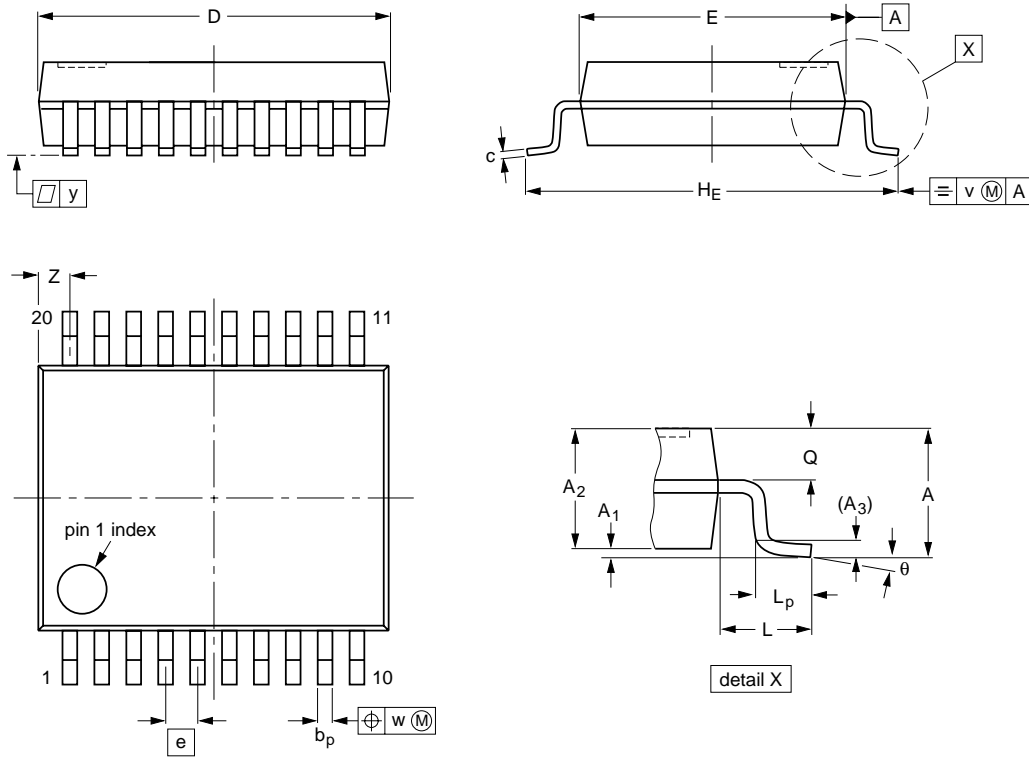

DIMENSIONS (mm are the original dimensions)

UNIT	A max.	A <sub>1</sub>	A <sub>2</sub>	A <sub>3</sub>	b <sub>p</sub>	c	D <sup>(1)</sup>	E <sup>(1)</sup>	e	H <sub>E</sub>	L	L <sub>p</sub>	Q	v	w	y	Z <sup>(1)</sup>	θ
mm	2.0	0.21 0.05	1.80 1.65	0.25	0.38 0.25	0.20 0.09	7.4 7.0	5.4 5.2	0.65	7.9 7.6	1.25	1.03 0.63	0.9 0.7	0.2	0.13	0.1	0.9 0.5	8° 0°

Note

1. Plastic or metal protrusions of 0.20 mm maximum per side are not included.

OUTLINE VERSION	REFERENCES				EUROPEAN PROJECTION	ISSUE DATE
	IEC	JEDEC	EIAJ			
SOT339-1		MO-150AE				93-09-08 95-02-04



## Fast charge ICs for NiCd, NiMH, SLA and Lilon

## TEA1102; TEA1102T; TEA1102TS

### SOLDERING

#### Introduction

This text gives a very brief insight to a complex technology. A more in-depth account of soldering ICs can be found in our "Data Handbook IC26; Integrated Circuit Packages" (document order number 9398 652 90011).

There is no soldering method that is ideal for all IC packages. Wave soldering is often preferred when through-hole and surface mount components are mixed on one printed-circuit board. However, wave soldering is not always suitable for surface mount ICs, or for printed-circuit boards with high population densities. In these situations reflow soldering is often used.

#### Through-hole mount packages

##### SOLDERING BY DIPPING OR BY SOLDER WAVE

The maximum permissible temperature of the solder is 260 °C; solder at this temperature must not be in contact with the joints for more than 5 seconds. The total contact time of successive solder waves must not exceed 5 seconds.

The device may be mounted up to the seating plane, but the temperature of the plastic body must not exceed the specified maximum storage temperature ( $T_{stg(max)}$ ). If the printed-circuit board has been pre-heated, forced cooling may be necessary immediately after soldering to keep the temperature within the permissible limit.

##### MANUAL SOLDERING

Apply the soldering iron (24 V or less) to the lead(s) of the package, either below the seating plane or not more than 2 mm above it. If the temperature of the soldering iron bit is less than 300 °C it may remain in contact for up to 10 seconds. If the bit temperature is between 300 and 400 °C, contact may be up to 5 seconds.

#### Surface mount packages

##### REFLOW SOLDERING

Reflow soldering requires solder paste (a suspension of fine solder particles, flux and binding agent) to be applied to the printed-circuit board by screen printing, stencilling or pressure-syringe dispensing before package placement.

Several methods exist for reflowing; for example, infrared/convection heating in a conveyor type oven. Throughput times (preheating, soldering and cooling) vary between 100 and 200 seconds depending on heating method.

Typical reflow peak temperatures range from 215 to 250 °C. The top-surface temperature of the packages should preferably be kept below 230 °C.

##### WAVE SOLDERING

Conventional single wave soldering is not recommended for surface mount devices (SMDs) or printed-circuit boards with a high component density, as solder bridging and non-wetting can present major problems.

To overcome these problems the double-wave soldering method was specifically developed.

If wave soldering is used the following conditions must be observed for optimal results:

- Use a double-wave soldering method comprising a turbulent wave with high upward pressure followed by a smooth laminar wave.
- For packages with leads on two sides and a pitch (e):
  - larger than or equal to 1.27 mm, the footprint longitudinal axis is **preferred** to be parallel to the transport direction of the printed-circuit board;
  - smaller than 1.27 mm, the footprint longitudinal axis **must** be parallel to the transport direction of the printed-circuit board.

The footprint must incorporate solder thieves at the downstream end.

- For packages with leads on four sides, the footprint must be placed at a 45° angle to the transport direction of the printed-circuit board. The footprint must incorporate solder thieves downstream and at the side corners.

During placement and before soldering, the package must be fixed with a droplet of adhesive. The adhesive can be applied by screen printing, pin transfer or syringe dispensing. The package can be soldered after the adhesive is cured.

Typical dwell time is 4 seconds at 250 °C.

A mildly-activated flux will eliminate the need for removal of corrosive residues in most applications.

##### MANUAL SOLDERING

Fix the component by first soldering two diagonally-opposite end leads. Use a low voltage (24 V or less) soldering iron applied to the flat part of the lead. Contact time must be limited to 10 seconds at up to 300 °C.

When using a dedicated tool, all other leads can be soldered in one operation within 2 to 5 seconds between 270 and 320 °C.

# Fast charge ICs for NiCd, NiMH, SLA and Lilon

# TEA1102; TEA1102T; TEA1102TS

## Suitability of IC packages for wave, reflow and dipping soldering methods

MOUNTING	PACKAGE	SOLDERING METHOD		
		WAVE	REFLOW <sup>(1)</sup>	DIPPING
Through-hole mount	DBS, DIP, HDIP, SDIP, SIL	suitable <sup>(2)</sup>	–	suitable
Surface mount	HLQFP, HSQFP, HSOP, SMS	not suitable <sup>(3)</sup>	suitable	–
	PLCC <sup>(4)</sup> , SO	suitable	suitable	–
	LQFP, QFP, TQFP	not recommended <sup>(4)(5)</sup>	suitable	–
	SQFP	not suitable	suitable	–
	SSOP, TSSOP, VSO	not recommended <sup>(6)</sup>	suitable	–

### Notes

- All surface mount (SMD) packages are moisture sensitive. Depending upon the moisture content, the maximum temperature (with respect to time) and body size of the package, there is a risk that internal or external package cracks may occur due to vaporization of the moisture in them (the so called popcorn effect). For details, refer to the Drypack information in the "Data Handbook IC26; Integrated Circuit Packages; Section: Packing Methods".
- For SDIP packages, the longitudinal axis must be parallel to the transport direction of the printed-circuit board.
- These packages are not suitable for wave soldering as a solder joint between the printed-circuit board and heatsink (at bottom version) can not be achieved, and as solder may stick to the heatsink (on top version).
- If wave soldering is considered, then the package must be placed at a 45° angle to the solder wave direction. The package footprint must incorporate solder thieves downstream and at the side corners.
- Wave soldering is only suitable for LQFP, QFP and TQFP packages with a pitch (e) equal to or larger than 0.8 mm; it is definitely not suitable for packages with a pitch (e) equal to or smaller than 0.65 mm.
- Wave soldering is only suitable for SSOP and TSSOP packages with a pitch (e) equal to or larger than 0.65 mm; it is definitely not suitable for packages with a pitch (e) equal to or smaller than 0.5 mm.

### DEFINITIONS

Data sheet status	
Objective specification	This data sheet contains target or goal specifications for product development.
Preliminary specification	This data sheet contains preliminary data; supplementary data may be published later.
Product specification	This data sheet contains final product specifications.
Limiting values	
Limiting values given are in accordance with the Absolute Maximum Rating System (IEC 134). Stress above one or more of the limiting values may cause permanent damage to the device. These are stress ratings only and operation of the device at these or at any other conditions above those given in the Characteristics sections of the specification is not implied. Exposure to limiting values for extended periods may affect device reliability.	
Application information	
Where application information is given, it is advisory and does not form part of the specification.	

### LIFE SUPPORT APPLICATIONS

These products are not designed for use in life support appliances, devices, or systems where malfunction of these products can reasonably be expected to result in personal injury. Philips customers using or selling these products for use in such applications do so at their own risk and agree to fully indemnify Philips for any damages resulting from such improper use or sale.

---

Fast charge ICs for NiCd, NiMH, SLA and  
Lilon

TEA1102; TEA1102T;  
TEA1102TS

---

**NOTES**

# Philips Semiconductors – a worldwide company

**Argentina:** see South America

**Australia:** 34 Waterloo Road, NORTH RYDE, NSW 2113,  
Tel. +61 2 9805 4455, Fax. +61 2 9805 4466

**Austria:** Computerstr. 6, A-1101 WIEN, P.O. Box 213,  
Tel. +43 1 60 101 1248, Fax. +43 1 60 101 1210

**Belarus:** Hotel Minsk Business Center, Bld. 3, r. 1211, Volodarski Str. 6,  
220050 MINSK, Tel. +375 172 20 0733, Fax. +375 172 20 0773

**Belgium:** see The Netherlands

**Brazil:** see South America

**Bulgaria:** Philips Bulgaria Ltd., Energoproject, 15th floor,  
51 James Bourchier Blvd., 1407 SOFIA,  
Tel. +359 2 68 9211, Fax. +359 2 68 9102

**Canada:** PHILIPS SEMICONDUCTORS/COMPONENTS,  
Tel. +1 800 234 7381, Fax. +1 800 943 0087

**China/Hong Kong:** 501 Hong Kong Industrial Technology Centre,  
72 Tat Chee Avenue, Kowloon Tong, HONG KONG,  
Tel. +852 2319 7888, Fax. +852 2319 7700

**Colombia:** see South America

**Czech Republic:** see Austria

**Denmark:** Sydhavnsgade 23, 1780 COPENHAGEN V,  
Tel. +45 33 29 3333, Fax. +45 33 29 3905

**Finland:** Sinikalliontie 3, FIN-02630 ESPOO,  
Tel. +358 9 615 800, Fax. +358 9 6158 0920

**France:** 51 Rue Carnot, BP317, 92156 SURESNES Cedex,  
Tel. +33 1 4099 6161, Fax. +33 1 4099 6427

**Germany:** Hammerbrookstraße 69, D-20097 HAMBURG,  
Tel. +49 40 2353 60, Fax. +49 40 2353 6300

**Greece:** No. 15, 25th March Street, GR 17778 TAVROS/ATHENS,  
Tel. +30 1 489 4339/4239, Fax. +30 1 481 4240

**Hungary:** see Austria

**India:** Philips INDIA Ltd, Band Box Building, 2nd floor,  
254-D, Dr. Annie Besant Road, Worli, MUMBAI 400 025,  
Tel. +91 22 493 8541, Fax. +91 22 493 0966

**Indonesia:** PT Philips Development Corporation, Semiconductors Division,  
Gedung Philips, Jl. Buncit Raya Kav.99-100, JAKARTA 12510,  
Tel. +62 21 794 0040 ext. 2501, Fax. +62 21 794 0080

**Ireland:** Newstead, Clonskeagh, DUBLIN 14,  
Tel. +353 1 7640 000, Fax. +353 1 7640 200

**Israel:** RAPAC Electronics, 7 Kehilat Saloniki St, PO Box 18053,  
TEL AVIV 61180, Tel. +972 3 645 0444, Fax. +972 3 649 1007

**Italy:** PHILIPS SEMICONDUCTORS, Piazza IV Novembre 3,  
20124 MILANO, Tel. +39 2 6752 2531, Fax. +39 2 6752 2557

**Japan:** Philips Bldg 13-37, Kohnan 2-chome, Minato-ku,  
TOKYO 108-8507, Tel. +81 3 3740 5130, Fax. +81 3 3740 5077

**Korea:** Philips House, 260-199 Itaewon-dong, Yongsan-ku, SEOUL,  
Tel. +82 2 709 1412, Fax. +82 2 709 1415

**Malaysia:** No. 76 Jalan Universiti, 46200 PETALING JAYA, SELANGOR,  
Tel. +60 3 750 5214, Fax. +60 3 757 4880

**Mexico:** 5900 Gateway East, Suite 200, EL PASO, TEXAS 79905,  
Tel. +9-5 800 234 7381, Fax +9-5 800 943 0087

**Middle East:** see Italy

**Netherlands:** Postbus 90050, 5600 PB EINDHOVEN, Bldg. VB,  
Tel. +31 40 27 82785, Fax. +31 40 27 88399

**New Zealand:** 2 Wagener Place, C.P.O. Box 1041, AUCKLAND,  
Tel. +64 9 849 4160, Fax. +64 9 849 7811

**Norway:** Box 1, Manglerud 0612, OSLO,  
Tel. +47 22 74 8000, Fax. +47 22 74 8341

**Pakistan:** see Singapore

**Philippines:** Philips Semiconductors Philippines Inc.,  
106 Valero St. Salcedo Village, P.O. Box 2108 MCC, MAKATI,  
Metro MANILA, Tel. +63 2 816 6380, Fax. +63 2 817 3474

**Poland:** Ul. Lukiska 10, PL 04-123 WARSZAWA,  
Tel. +48 22 612 2831, Fax. +48 22 612 2327

**Portugal:** see Spain

**Romania:** see Italy

**Russia:** Philips Russia, Ul. Usatcheva 35A, 119048 MOSCOW,  
Tel. +7 095 755 6918, Fax. +7 095 755 6919

**Singapore:** Lorong 1, Toa Payoh, SINGAPORE 319762,  
Tel. +65 350 2538, Fax. +65 251 6500

**Slovakia:** see Austria

**Slovenia:** see Italy

**South Africa:** S.A. PHILIPS Pty Ltd., 195-215 Main Road Martindale,  
2092 JOHANNESBURG, P.O. Box 7430 Johannesburg 2000,  
Tel. +27 11 470 5911, Fax. +27 11 470 5494

**South America:** Al. Vicente Pinzon, 173, 6th floor,  
04547-130 SÃO PAULO, SP, Brazil,  
Tel. +55 11 821 2333, Fax. +55 11 821 2382

**Spain:** Balmes 22, 08007 BARCELONA,  
Tel. +34 93 301 6312, Fax. +34 93 301 4107

**Sweden:** Kottbygatan 7, Akalla, S-16485 STOCKHOLM,  
Tel. +46 8 5985 2000, Fax. +46 8 5985 2745

**Switzerland:** Allmendstrasse 140, CH-8027 ZÜRICH,  
Tel. +41 1 488 2741 Fax. +41 1 488 3263

**Taiwan:** Philips Semiconductors, 6F, No. 96, Chien Kuo N. Rd., Sec. 1,  
TAIPEI, Taiwan Tel. +886 2 2134 2865, Fax. +886 2 2134 2874

**Thailand:** PHILIPS ELECTRONICS (THAILAND) Ltd.,  
209/2 Sanpavuth-Bangna Road Prakanong, BANGKOK 10260,  
Tel. +66 2 745 4090, Fax. +66 2 398 0793

**Turkey:** Talatpasa Cad. No. 5, 80640 GÜLTEPE/ISTANBUL,  
Tel. +90 212 279 2770, Fax. +90 212 282 6707

**Ukraine:** PHILIPS UKRAINE, 4 Patrice Lumumba str., Building B, Floor 7,  
252042 KIEV, Tel. +380 44 264 2776, Fax. +380 44 268 0461

**United Kingdom:** Philips Semiconductors Ltd., 276 Bath Road, Hayes,  
MIDDLESEX UB3 5BX, Tel. +44 181 730 5000, Fax. +44 181 754 8421

**United States:** 811 East Arques Avenue, SUNNYVALE, CA 94088-3409,  
Tel. +1 800 234 7381, Fax. +1 800 943 0087

**Uruguay:** see South America

**Vietnam:** see Singapore

**Yugoslavia:** PHILIPS, Trg N. Pasica 5/v, 11000 BEOGRAD,  
Tel. +381 11 62 5344, Fax. +381 11 63 5777

**For all other countries apply to:** Philips Semiconductors,  
International Marketing & Sales Communications, Building BE-p, P.O. Box 218,  
5600 MD EINDHOVEN, The Netherlands, Fax. +31 40 27 24825

**Internet:** <http://www.semiconductors.philips.com>

© Philips Electronics N.V. 1999

SCA61

All rights are reserved. Reproduction in whole or in part is prohibited without the prior written consent of the copyright owner.

The information presented in this document does not form part of any quotation or contract, is believed to be accurate and reliable and may be changed without notice. No liability will be accepted by the publisher for any consequence of its use. Publication thereof does not convey nor imply any license under patent- or other industrial or intellectual property rights.

Printed in The Netherlands

465002/750/04/pp28

Date of release: 1999 Jan 27

Document order number: 9397 750 04793

*Let's make things better.*

**Philips**  
Semiconductors



**PHILIPS**

This datasheet has been download from:

[www.datasheetcatalog.com](http://www.datasheetcatalog.com)

Datasheets for electronics components.