

Stepping Motors

M42SP-7

OUTLINE

Standard type motor "M42SP-7" which belongs to the outer diameter 42mm model series. Despite 7.5° of step angle, and excitation method that are all in common with "M42SP-5", its body has been reduced to 15.7mm in thickness. This type is the most suited to any compact electronic apparatuses.



FEATURES

1. High output torque.
2. Superior running quietness and stability.
3. Step angle : 7.5°.
4. Excellent responsiveness acquired.

USES

Printers, multifunction machines, copy machines, FAX, and such.

SPECIFICATIONS

tems	M42SP-7	
Rated Voltage	DC 12V	DC 24V
Working Voltage	DC 10.8-13.2V	DC 21.6-26.4V
Rated Current/Phase	259mA	173mA
No. of Phase	4 Phase	4 Phase
Coil DC Resistance	50Ω/phase±7%	150Ω/phase±7%
Step Angle	7.5°/step	7.5°/step
Excitation Method	2-2 Phase excitation (Unipolar driving)	
Insulation Class	Class E insulation	Class E insulation
Holding Torque	49.0mN·m	52.9mN·m
Pull-out Torque	23.5mN·m/200pps	33.3mN·m/200pps
Pull-in Torque	19.6mN·m/200pps	29.4mN·m/200pps
Max. Pull-out Pulse Rate	600pps	650pps
Max. Pull-in Pulse Rate	420pps	430pps

CHARACTERISTICS

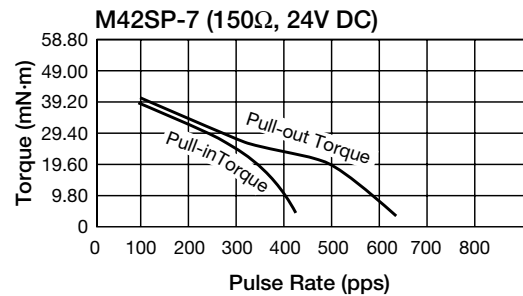
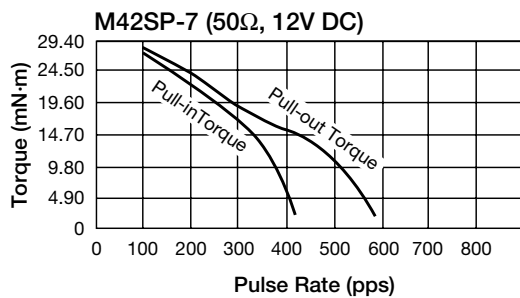

DIMENSIONS

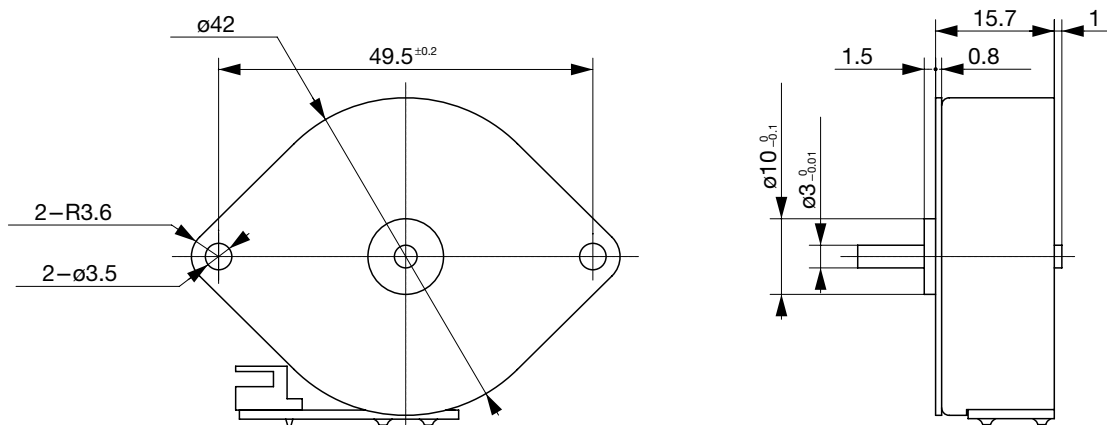

Unit : mm, General tolerance : ±0.5