

Descriptions

- General purpose application
- Switching application

Features

- Large collector current
- Low collector saturation voltage
- Complementary pair with STN2907A

Ordering Information

Type NO.	Marking	Package Code
STN2222A	STN2222A	TO-92

Outline Dimensions

unit : mm

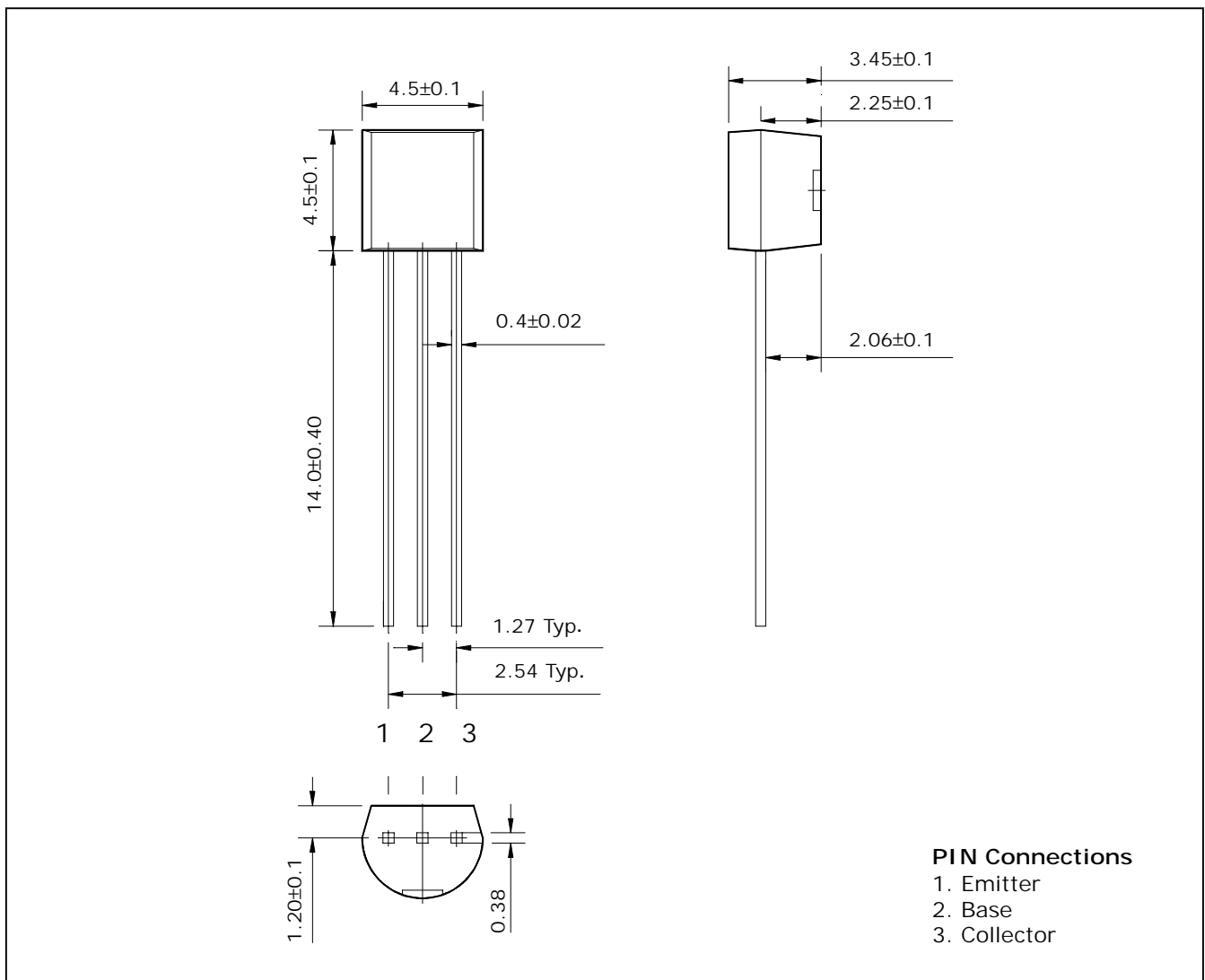

Absolute maximum ratings**T_a=25°C**

Characteristic	Symbol	Ratings	Unit
Collector-Base voltage	V _{CBO}	75	V
Collector-Emitter voltage	V _{CEO}	40	V
Emitter-base voltage	V _{EBO}	5	V
Collector current	I _C	600	mA
Collector dissipation	P _C	625	mW
Junction temperature	T _J	150	°C
Storage temperature	T _{stg}	-55 ~ 150	°C

Electrical Characteristics**T_a=25°C**

Characteristic	Symbol	Test Condition	Min.	Typ.	Max.	Unit
Collector-Base breakdown voltage	BV _{CBO}	I _C =10μA, I _E =0	75	-	-	V
Collector-Emitter breakdown voltage	BV _{CEO}	I _C =10mA, I _B =0	40	-	-	V
Emitter-Base breakdown voltage	BV _{EBO}	I _E =10μA, I _C =0	5	-	-	V
Collector cut-off current	I _{CBO}	V _{CB} =60V, I _E =0	-	-	10	nA
DC current gain	h _{FE}	V _{CE} =10V, I _C =10mA	75	-	-	-
Collector-Emitter saturation voltage	V _{CE(sat)}	I _C =150mA, I _B =15mA	-	-	0.5	V
Transistor frequency	f _T	V _{CE} =20V, I _C =20mA	250	-	-	MHz
Collector output capacitance	C _{ob}	V _{CB} =10V, I _E =0, f=1MHz	-	6.0	-	pF

Electrical Characteristic Curves

Fig. 1 P_C-T_a

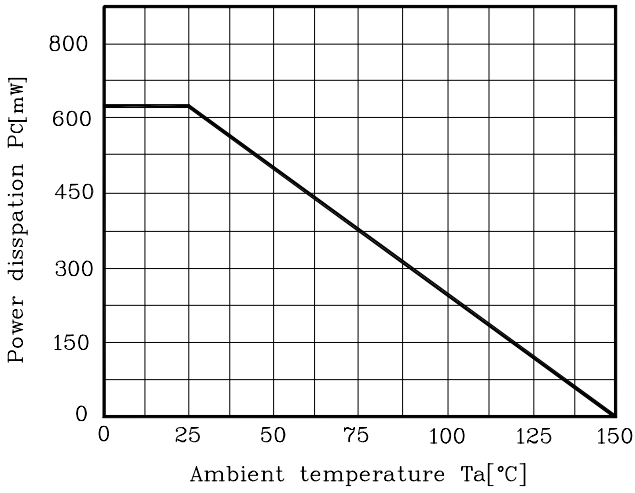

Fig. 2 I_C-V_{BE}

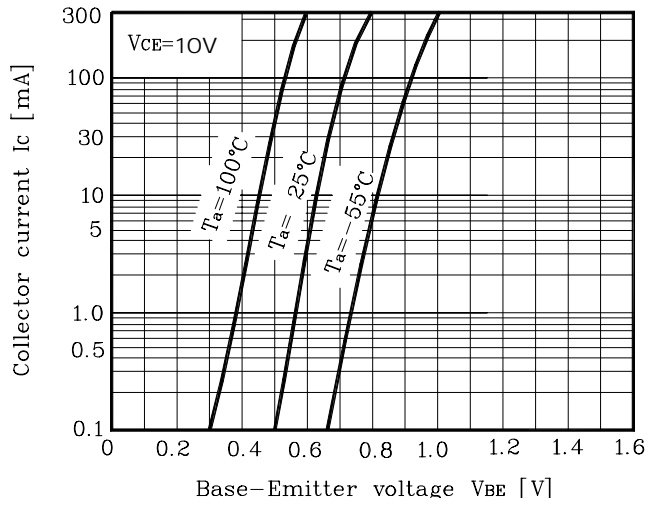

Fig. 3 I_C-V_{CE}

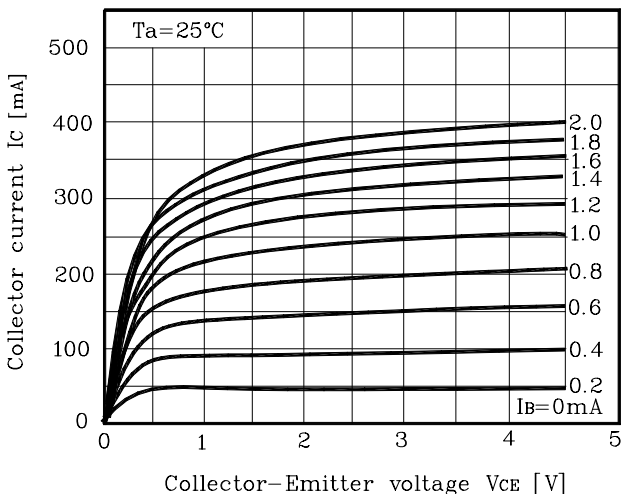

Fig. 4 $V_{CE(sat)}-I_C$

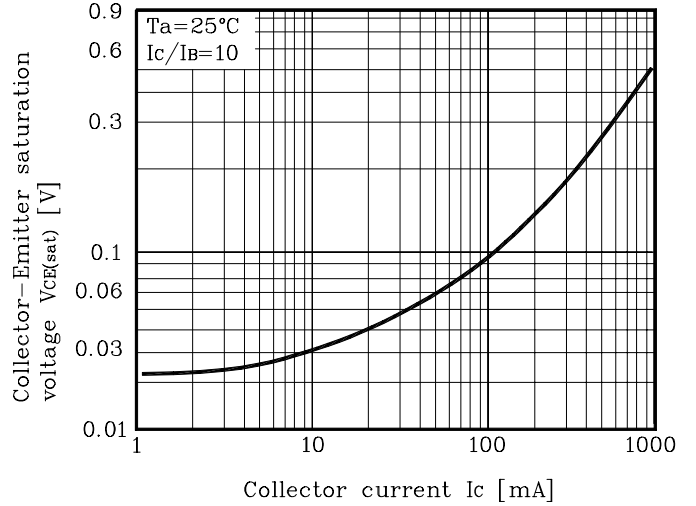

Fig. 5 $h_{FE}-I_C$

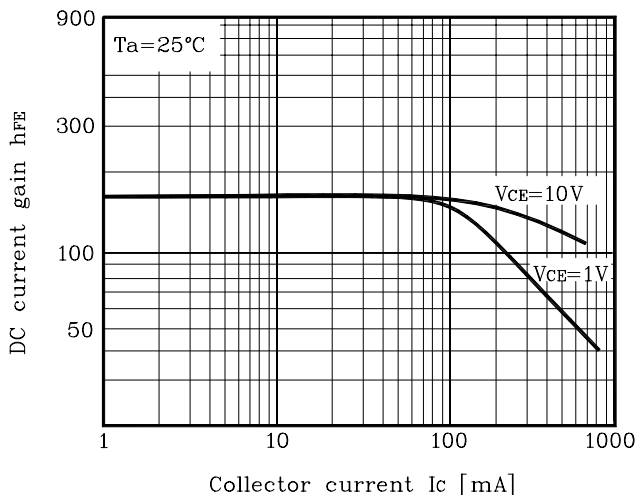

Fig. 6 $h_{FE}-I_C$

