

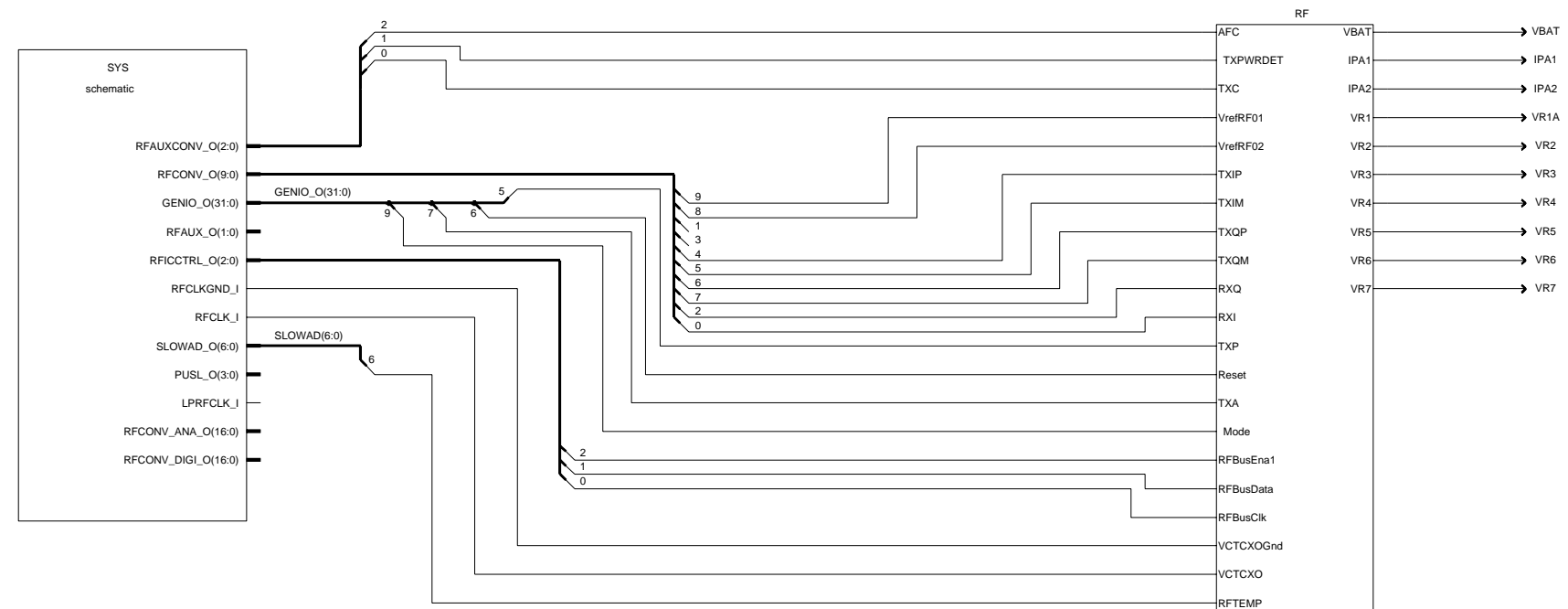

RM-37 Top Level

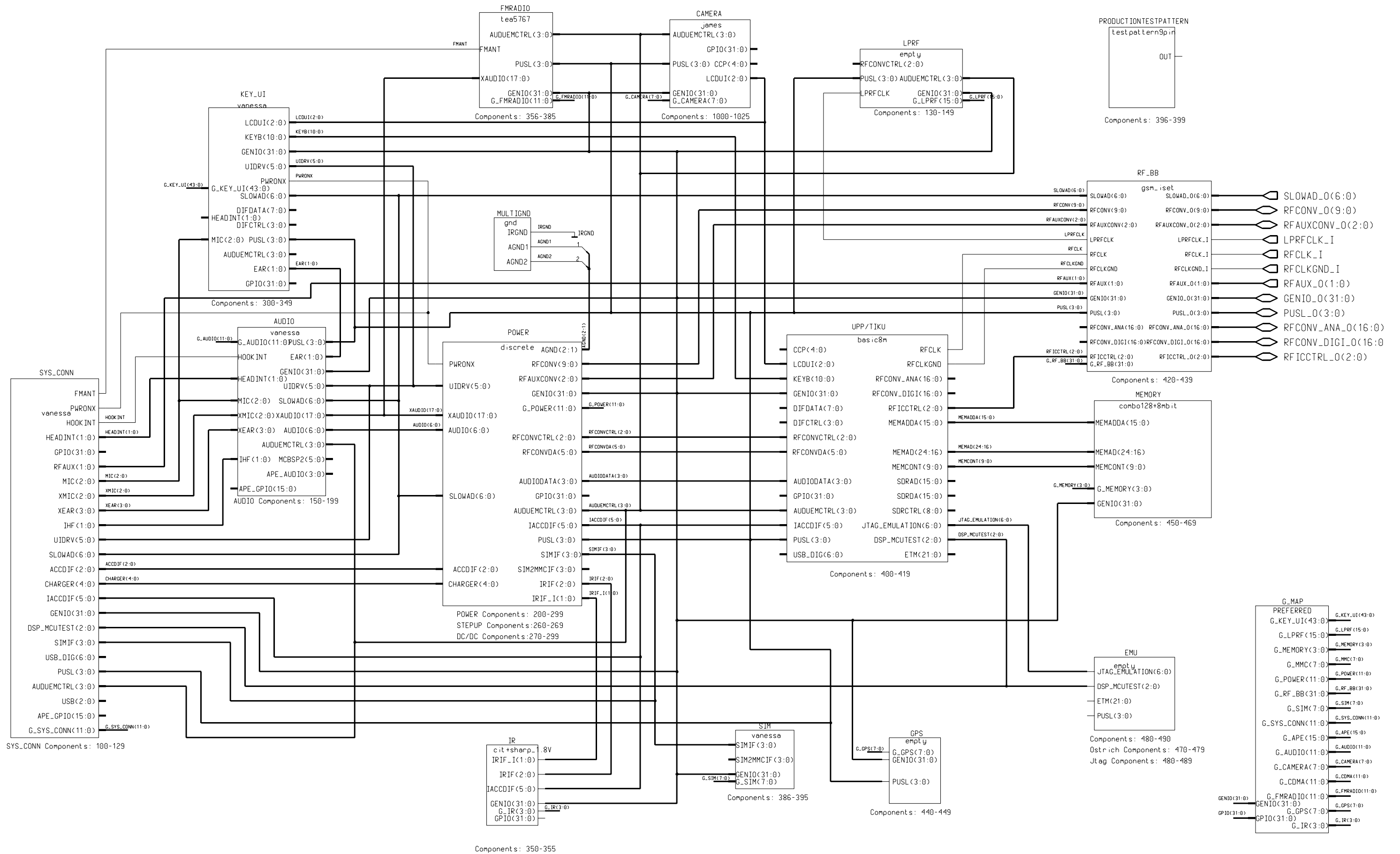

DCT4 Common BB



GENIO and GPIO Connection Block

GENIO(31:0) 

GPIO(31:0) 

 G_APE(15:0)

 G_AUDIO(11:0)

 G_CAMERA(7:0)

 G_CDMA(11:0)

 G_FMRADIO(11:0)

 G_GPS(7:0)

 G_IR(3:0)

 G_KEY_UI(43:0)

 G_LPRF(15:0)

 G_MEMORY(3:0)

 G_MMC(7:0)

 G_POWER(11:0)

 G_RF_BB(31:0)



 G_SIM(7:0)

 G_SYS_CONN(11:0)

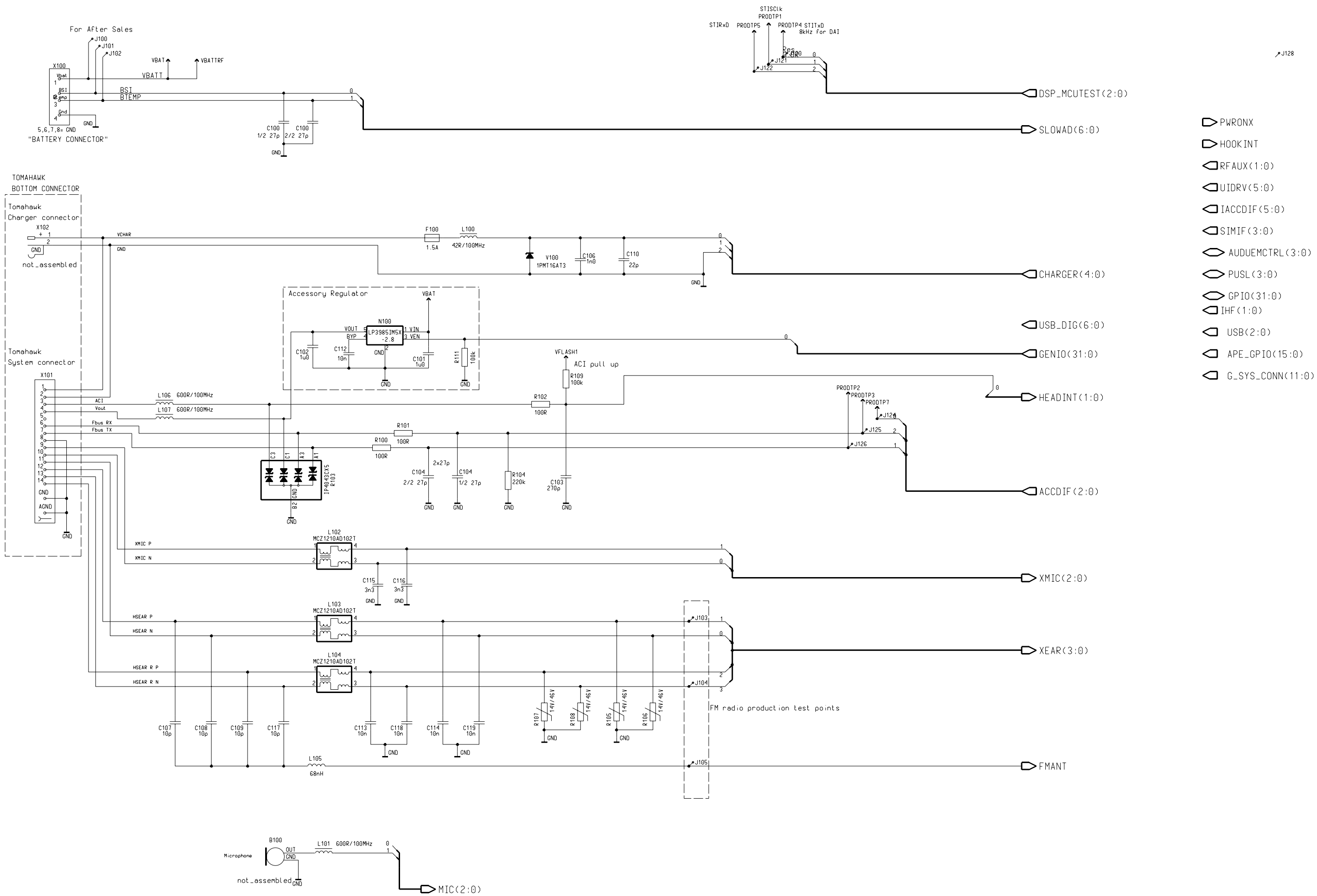
System Connector



UI

MIC(2:0) 
 PUSL(3:0) 

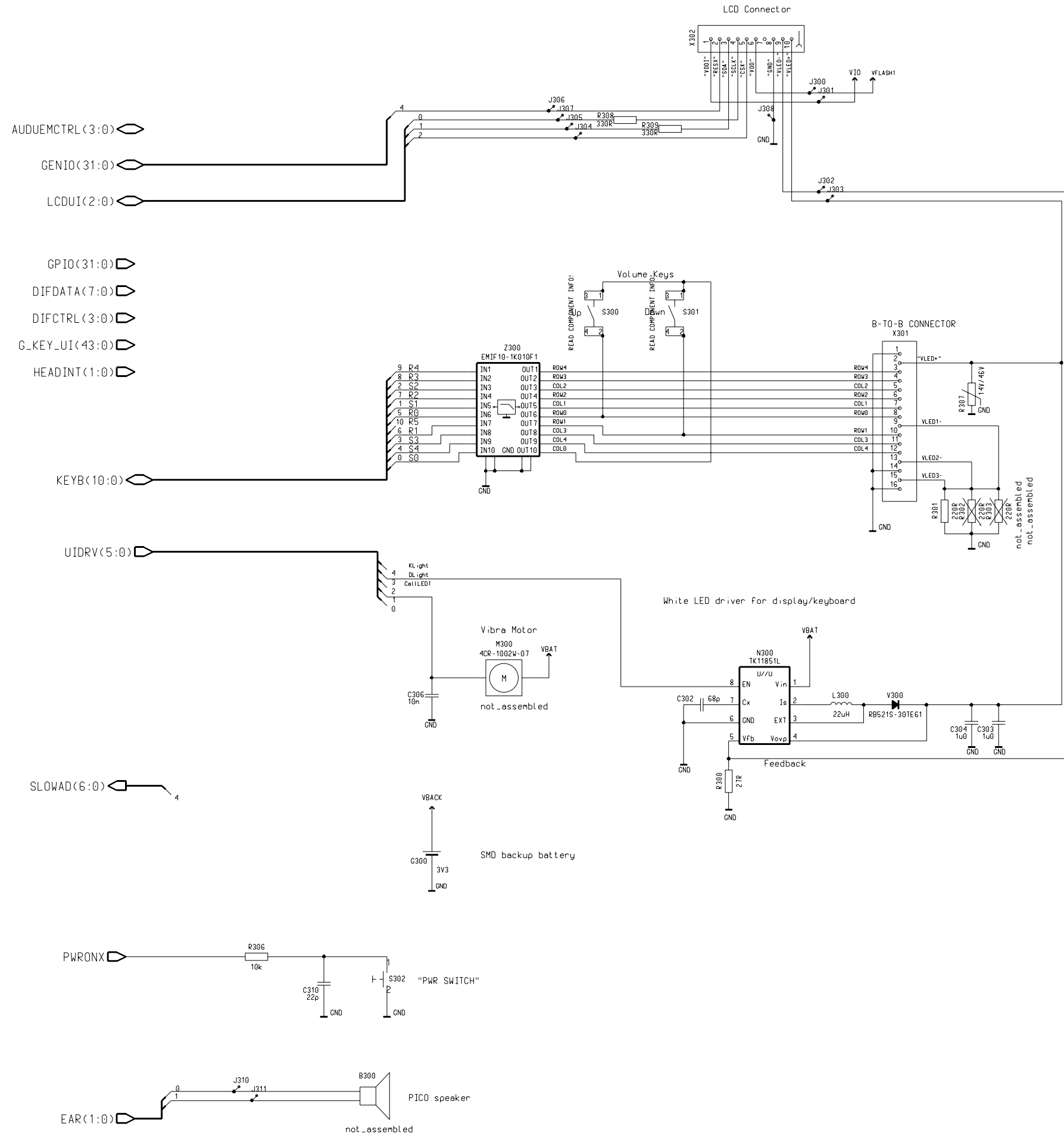

SIM Reader

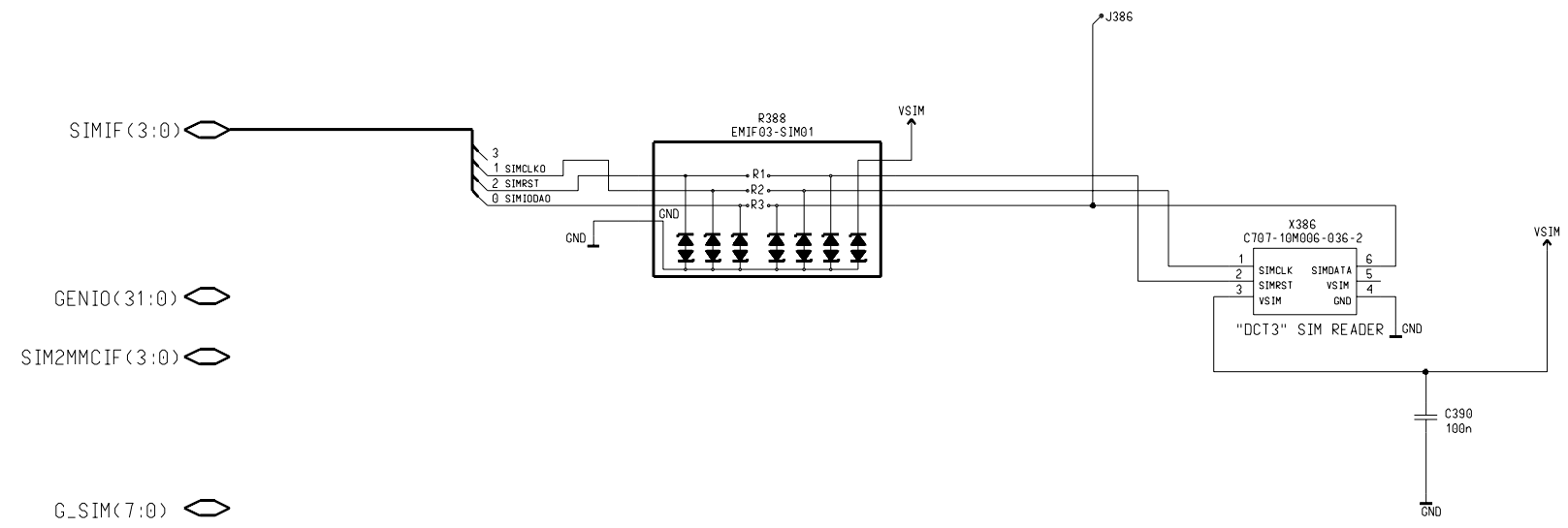

Discrete Power Management

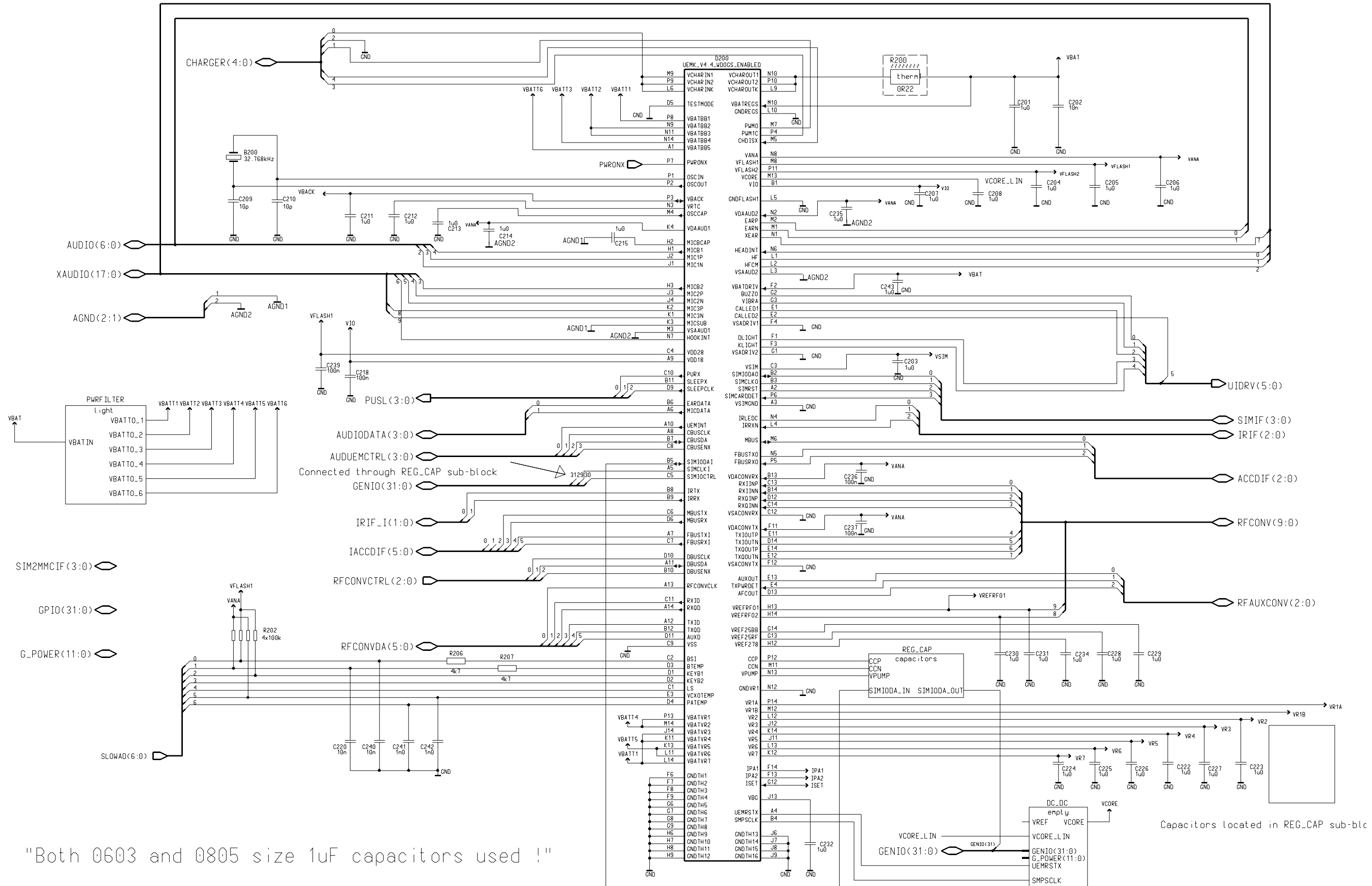

"Both 0603 and 0805 size 1uF capacitors used !"

Used refs in REG_CAP: C238, C200, C219, C233, C221 and R205

Capacitors located in REG_CAP sub-bloc

Light Filtering

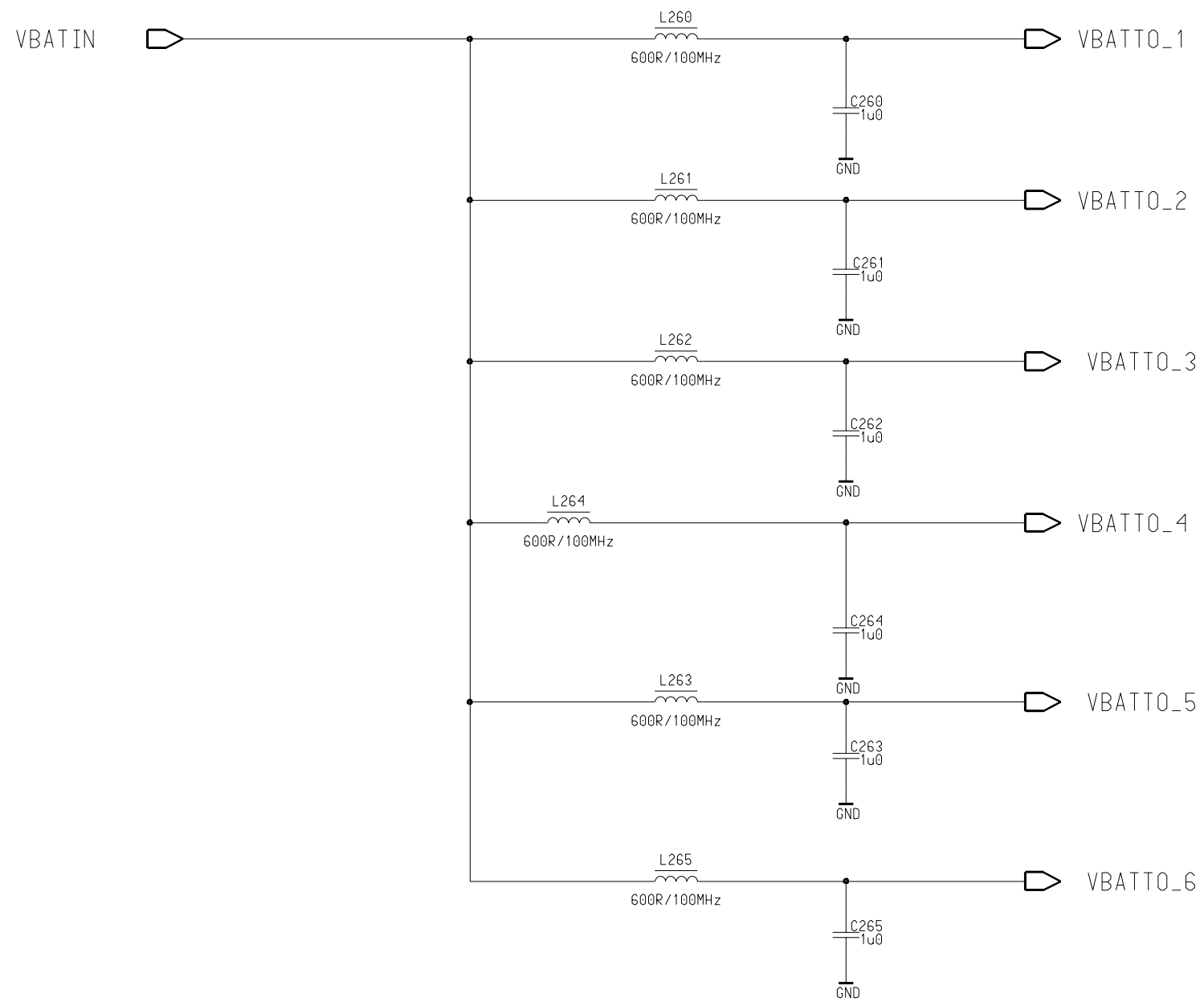



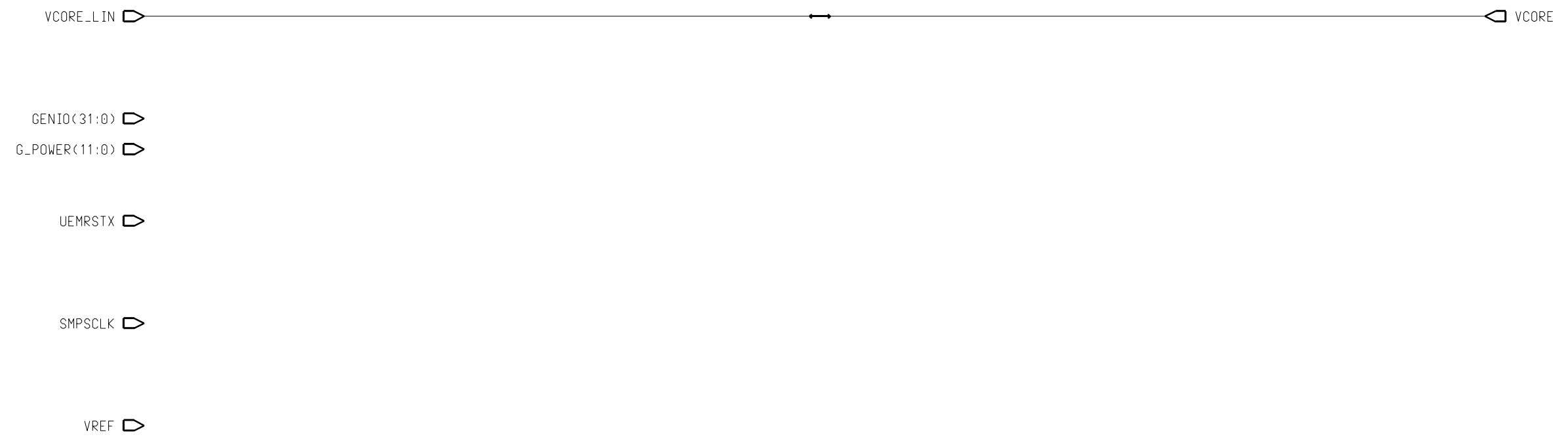

DC/DC Converter

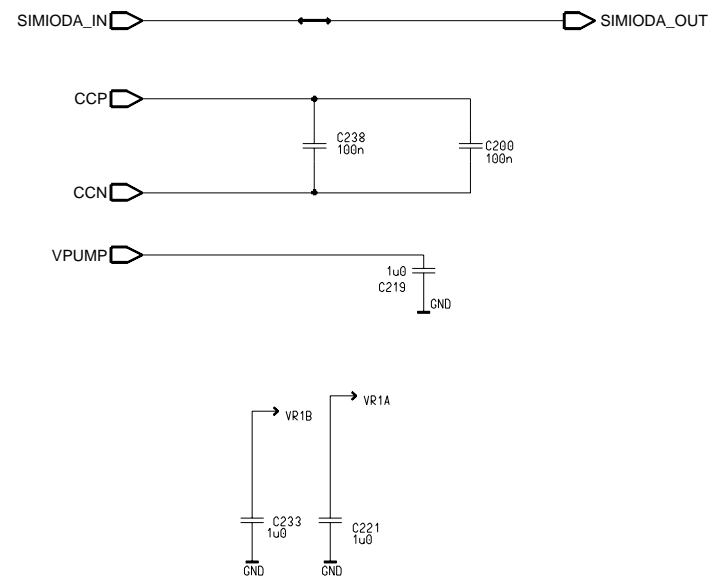

Old Power Discrete



Camera

- GPIO(31:0) 
- AUDUEMCTRL(3:0) 
- CCP(4:0) 
- PUSL(3:0) 

G_CAMERA(7:0) 

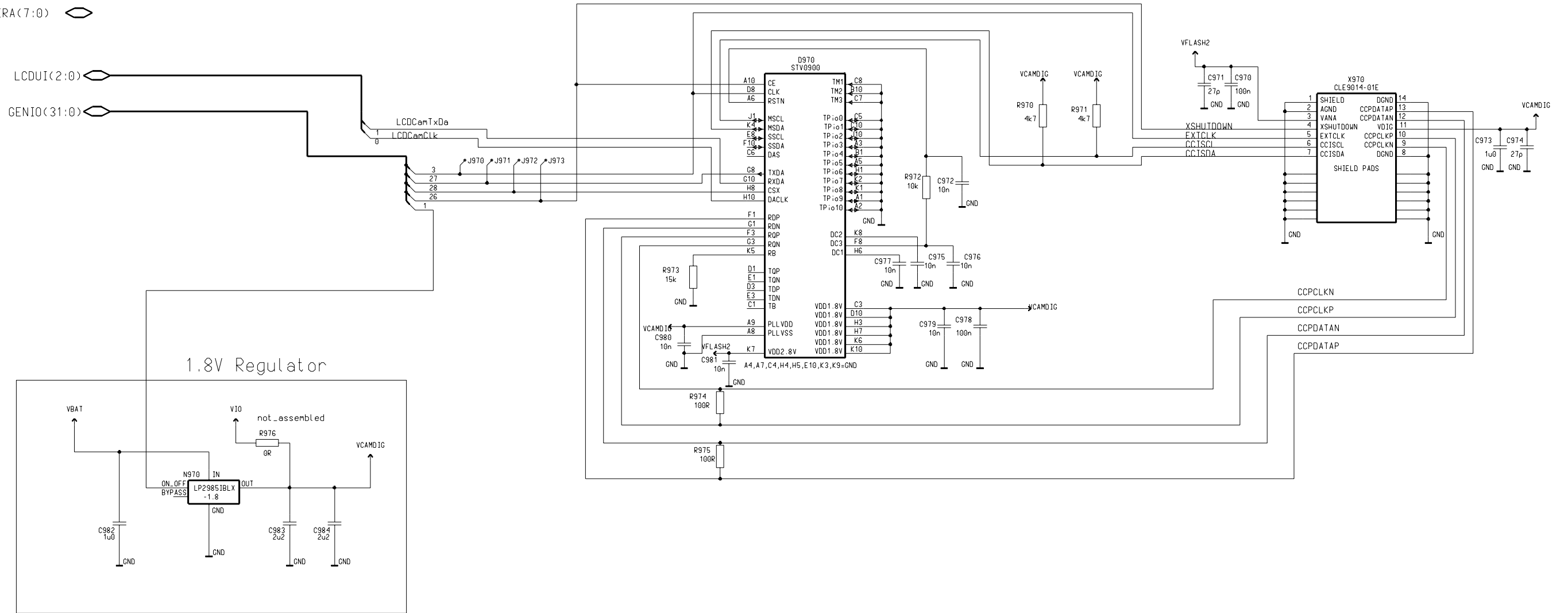

UPP 8M Implementation

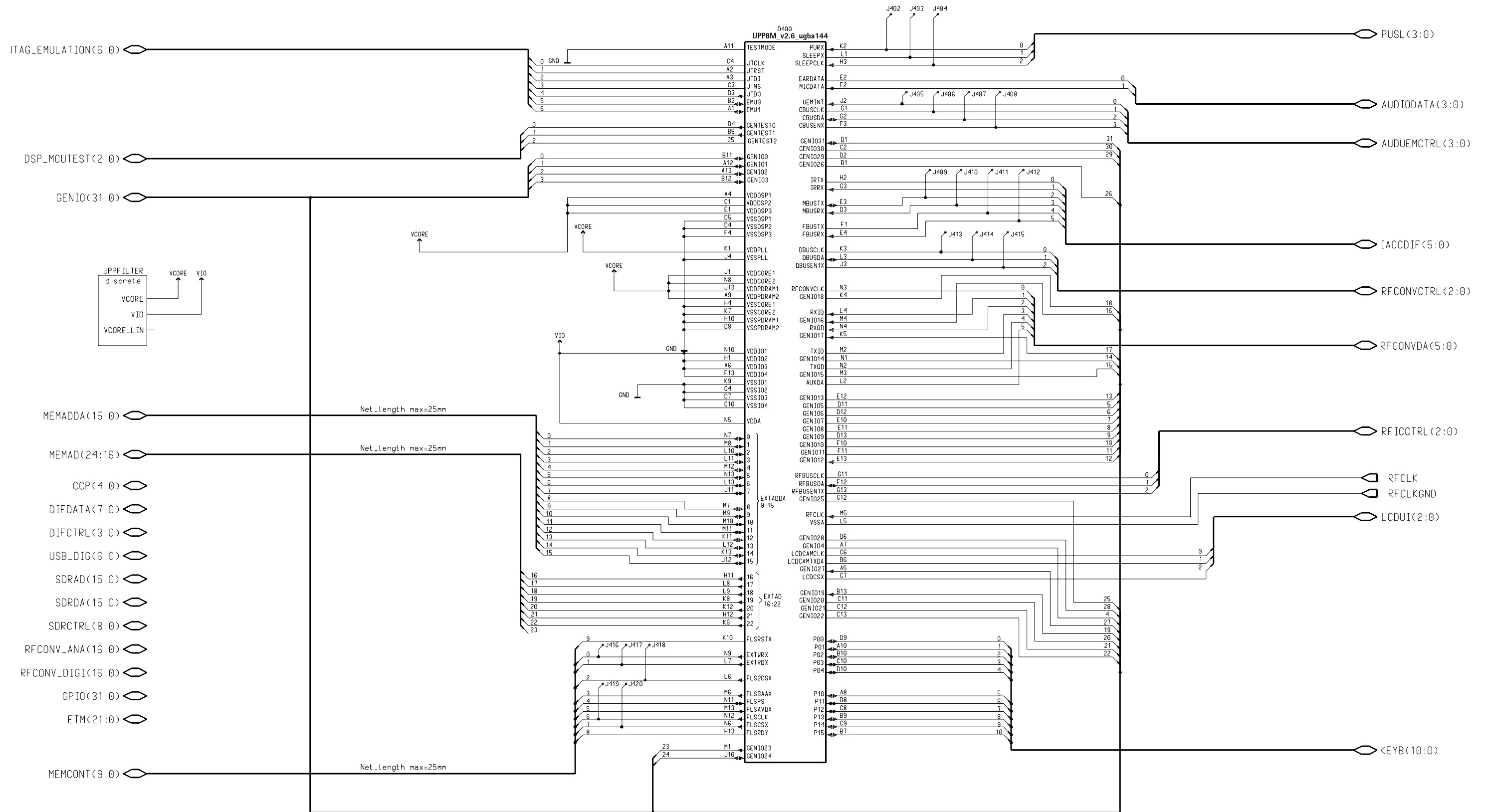

Decoupling Capacitors for UPP

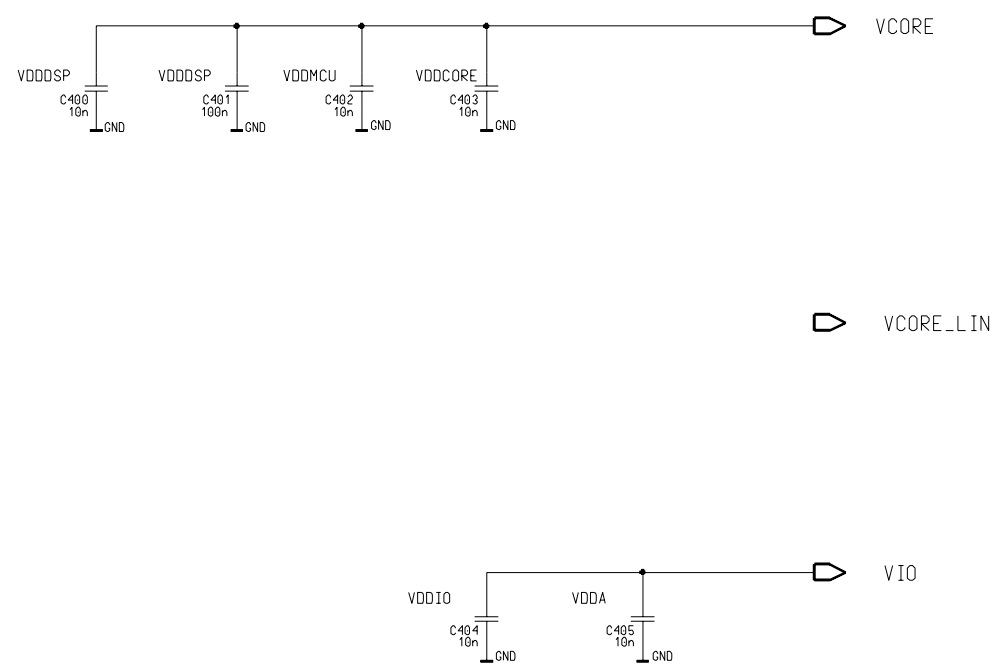

Combo Memory

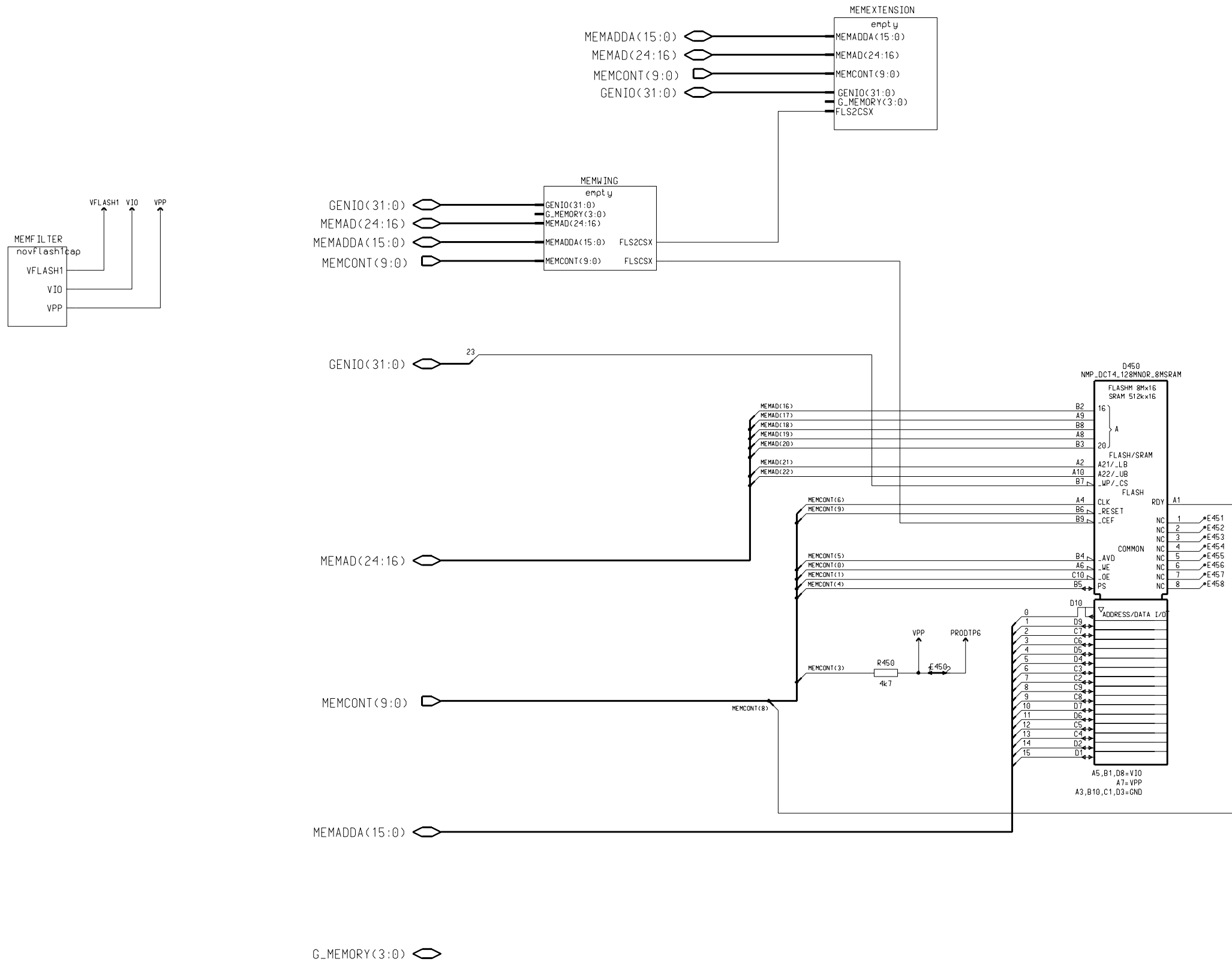

Memory Without VFLASH1

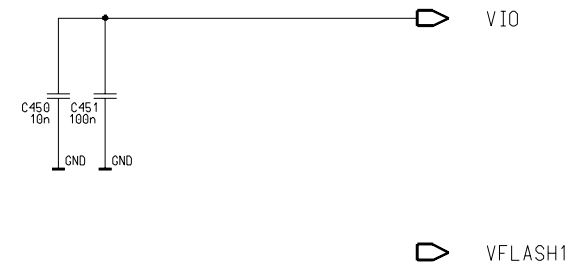

FM Radio

FMCLK = GENIO(24)

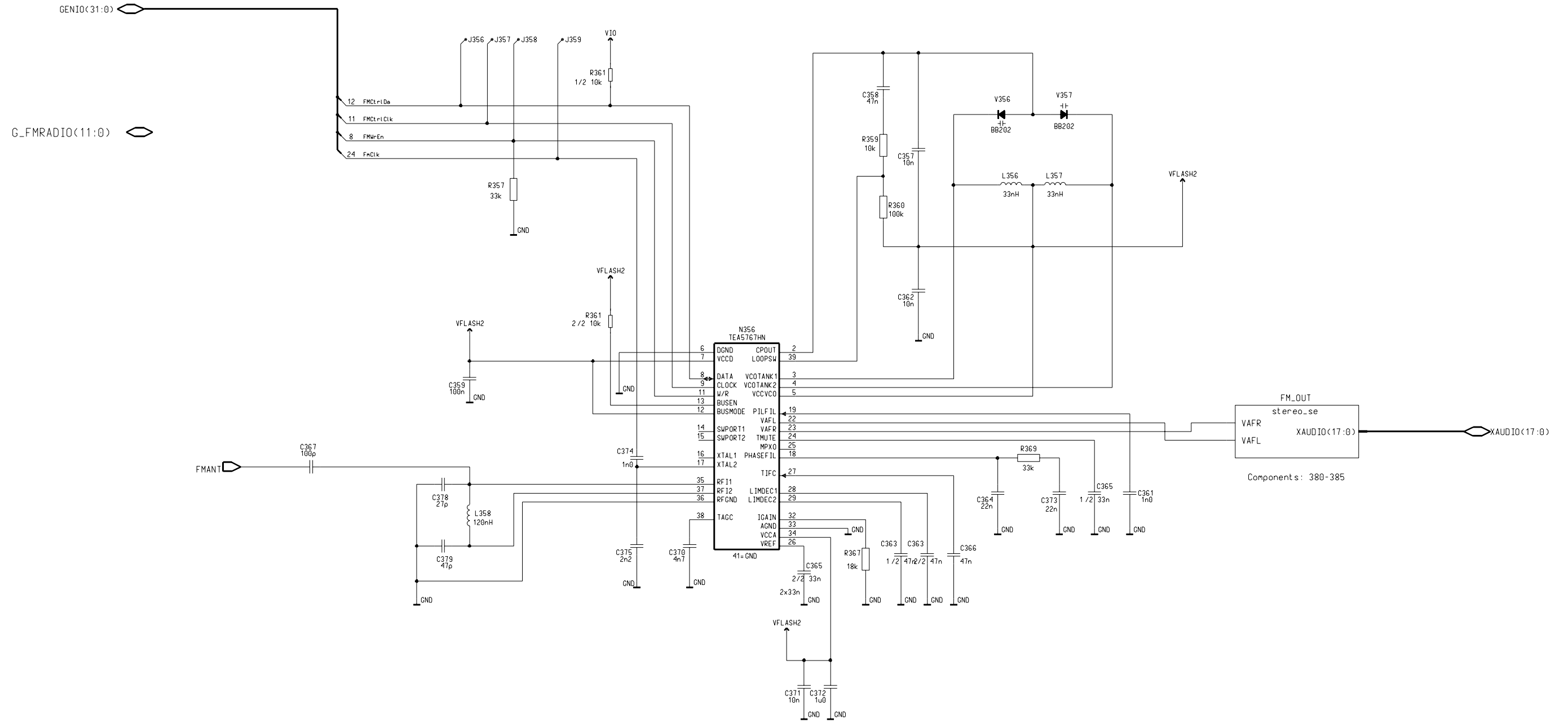

AUDJEMCTRL(3:0)

PUSL(3:0)

Notice:
 C374 (1n0) and C375 (2n2) are configured for 32kHz reference clock
 If reference clock is 6.5MHz, use C374 (3p9) and C375 (10p)

FM Radio Out

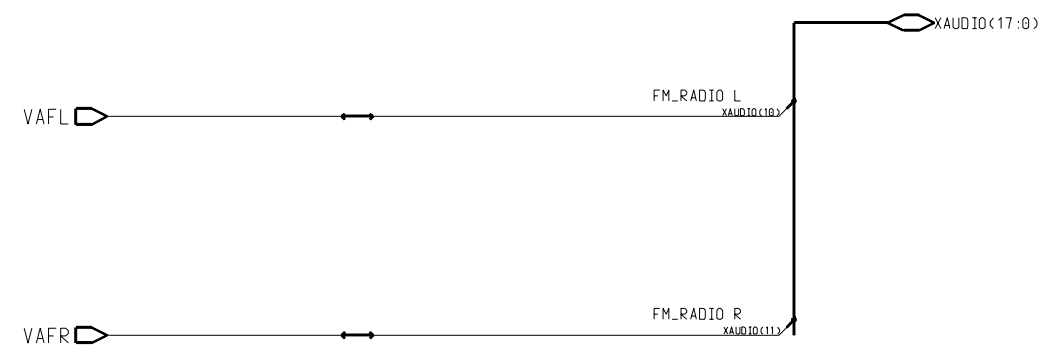

Test Pattern

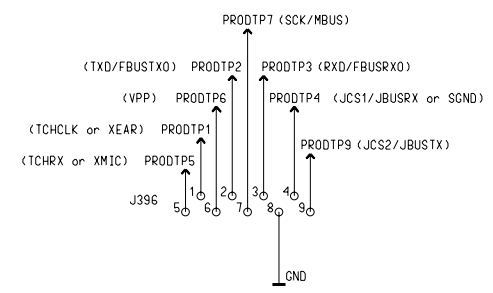

OUT

RF BB Interface

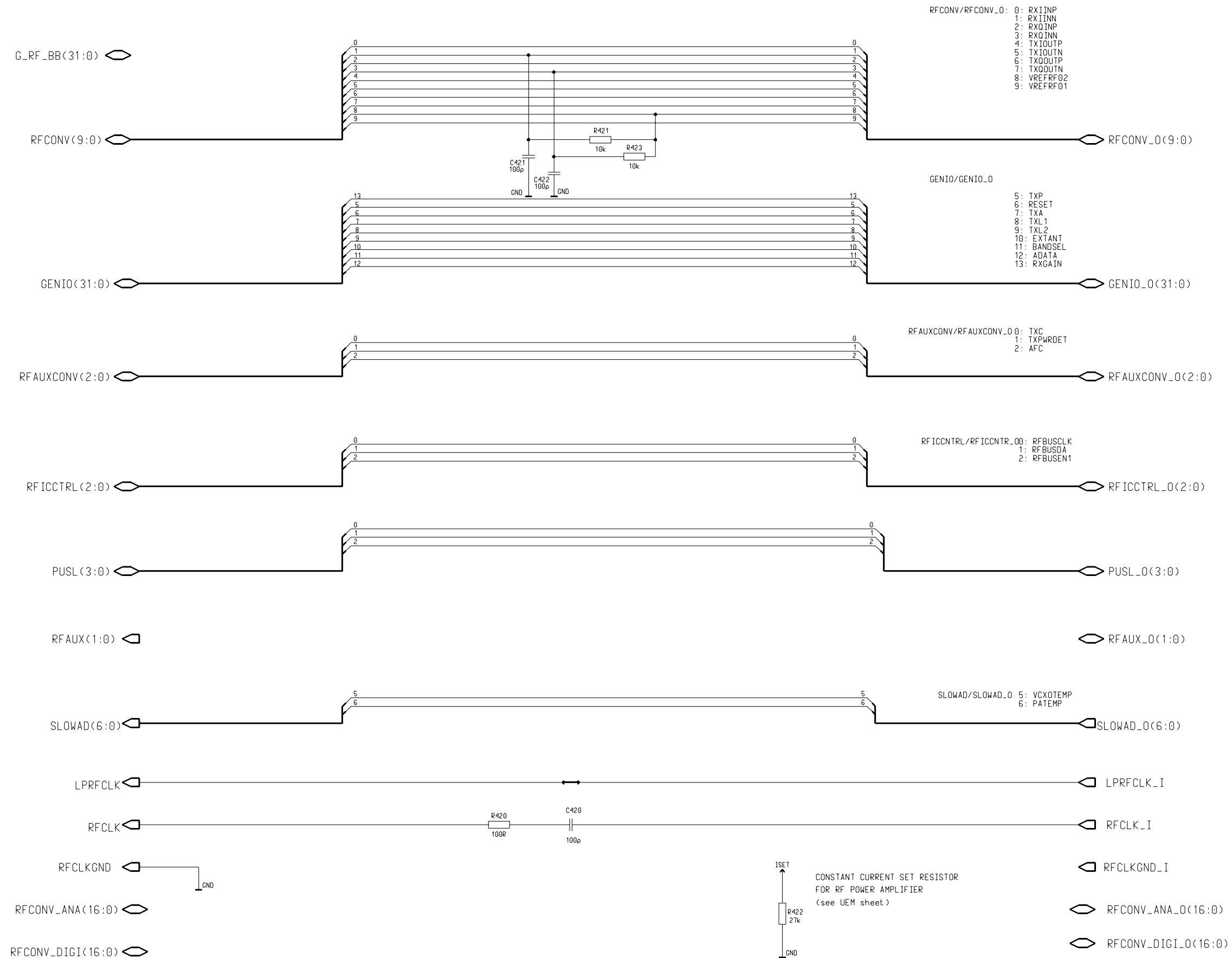

IPA1 AND IPA2 ARE USED IN RF, THE TOLERANCE OF R422 IS 1% (0402, 1430873)

Audio

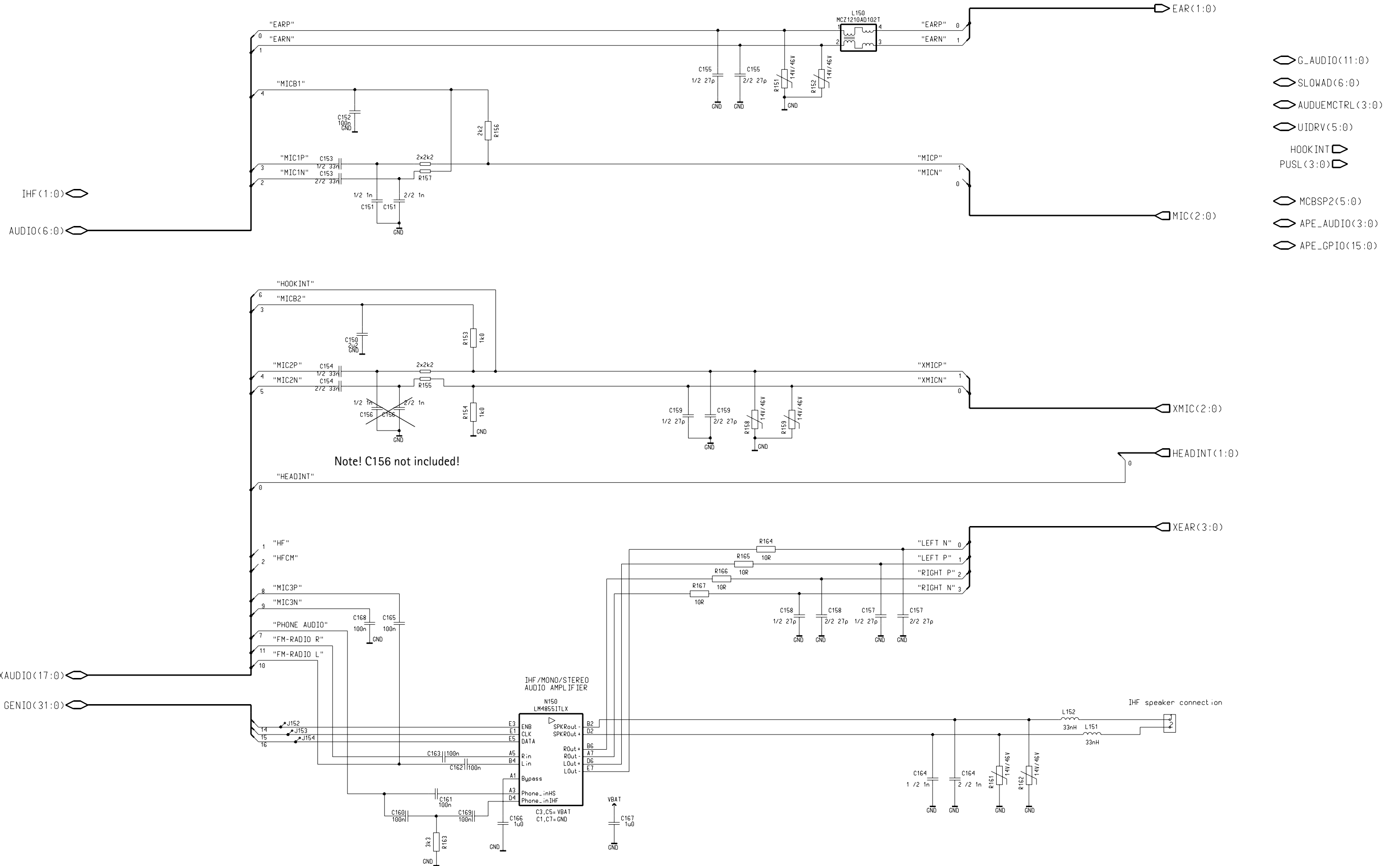

Multi GND

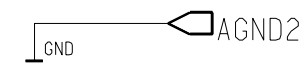
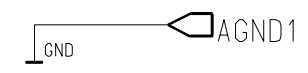
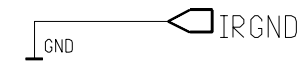

IR Module

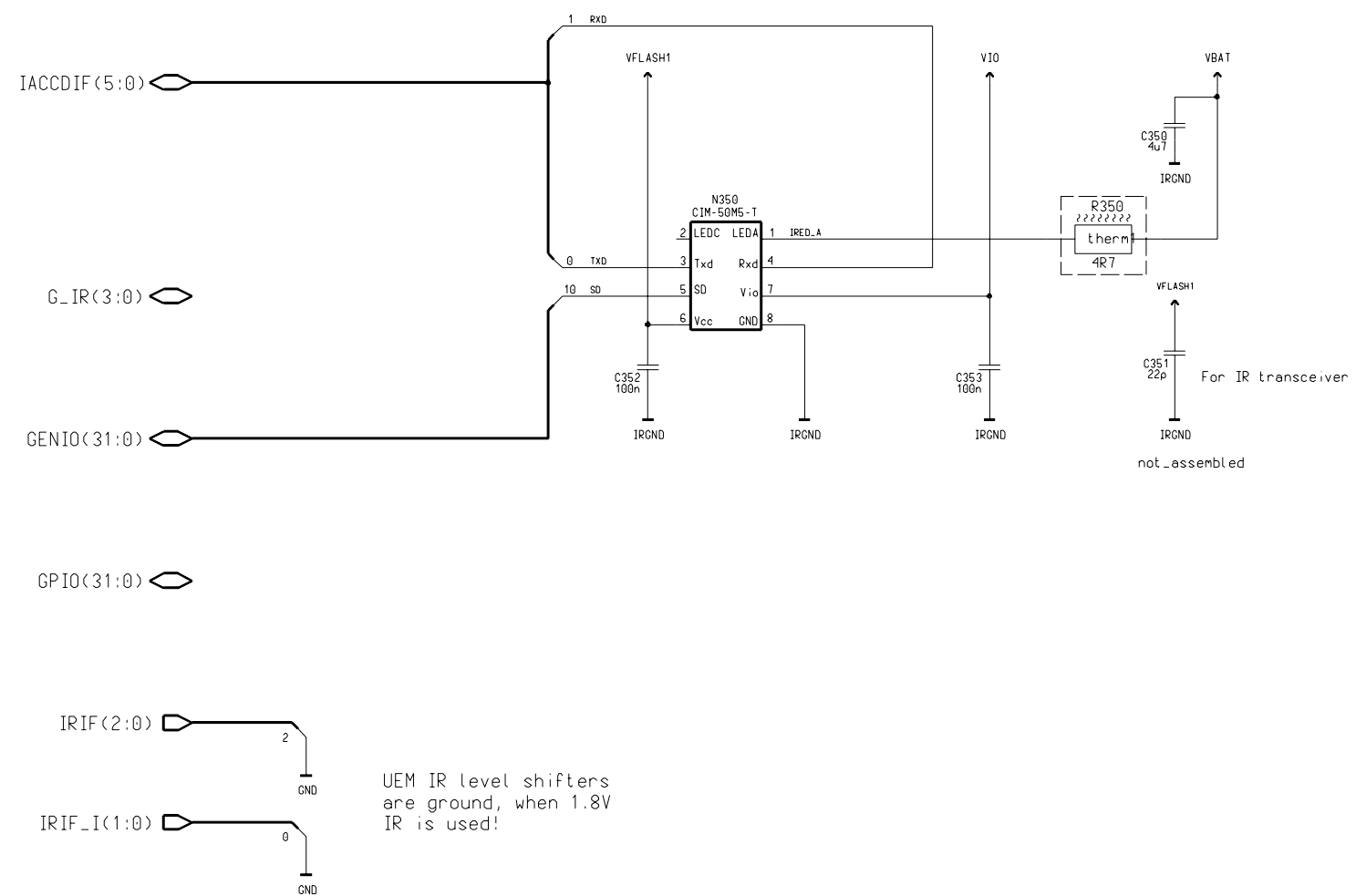

Used referenses

- C 350 - 353
- N 350
- R 350

RF

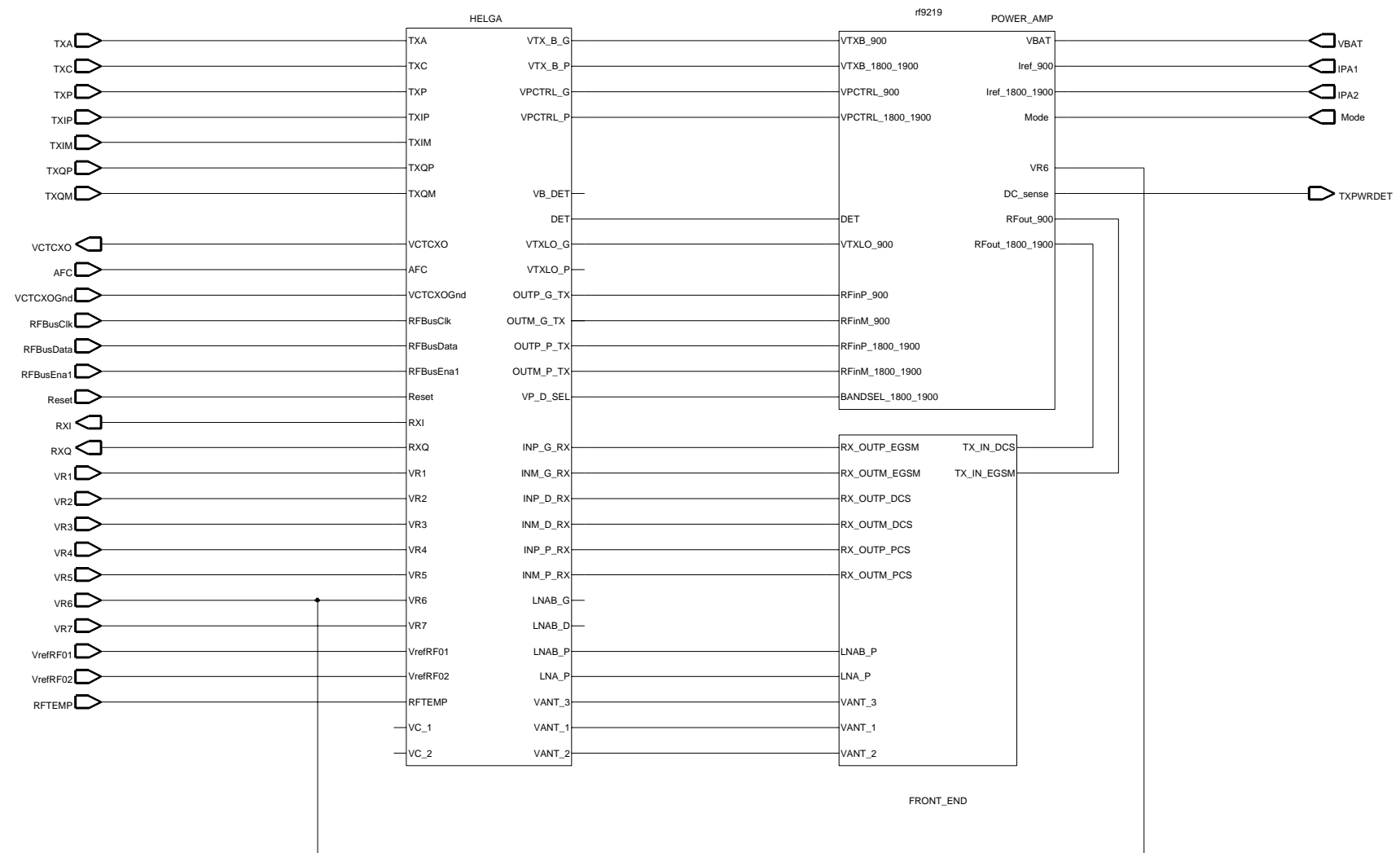

RF Shields and Vias

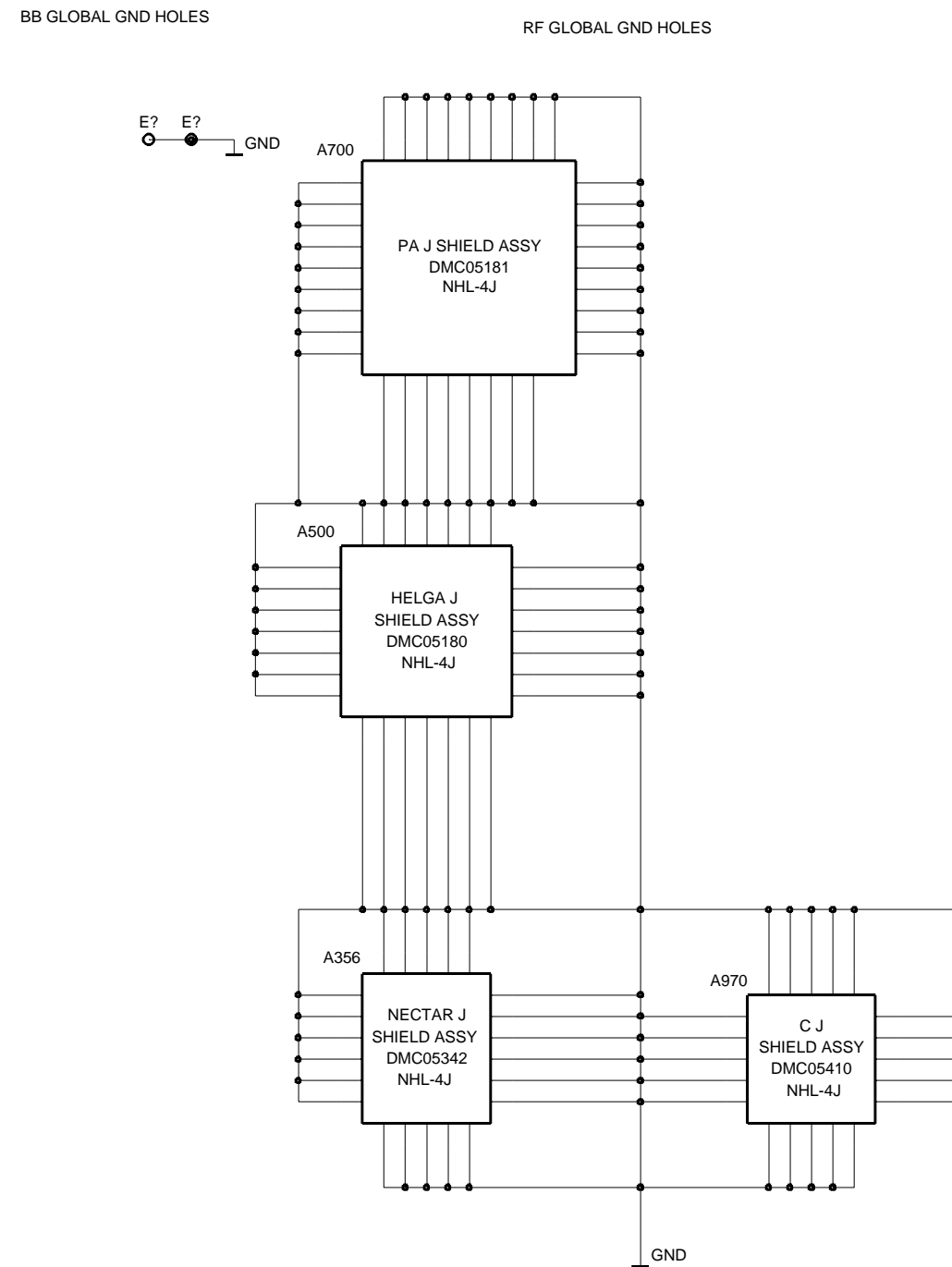

Power Amplifier and Detection

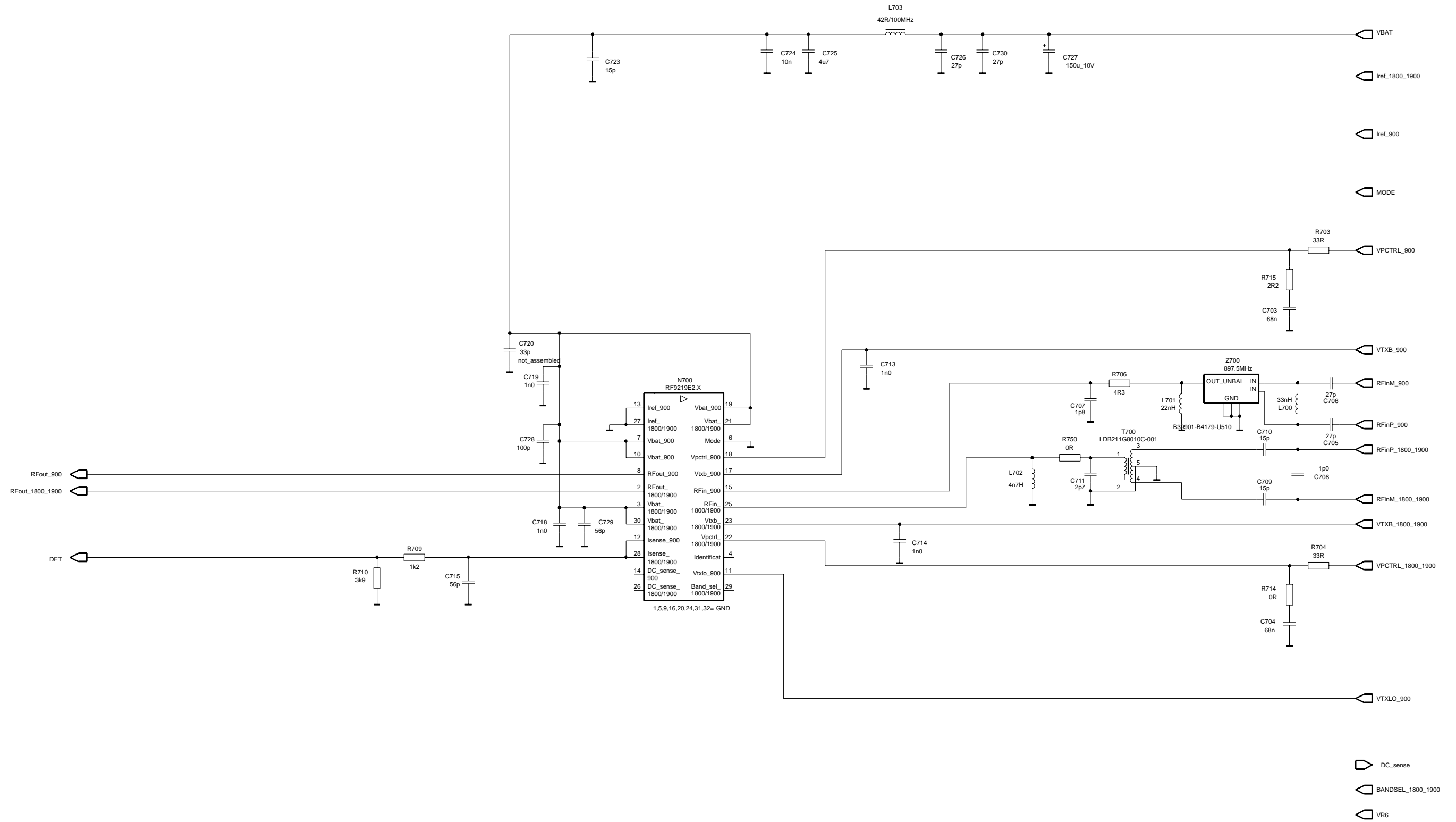

Last references:

C729

R715

L704

HELGA

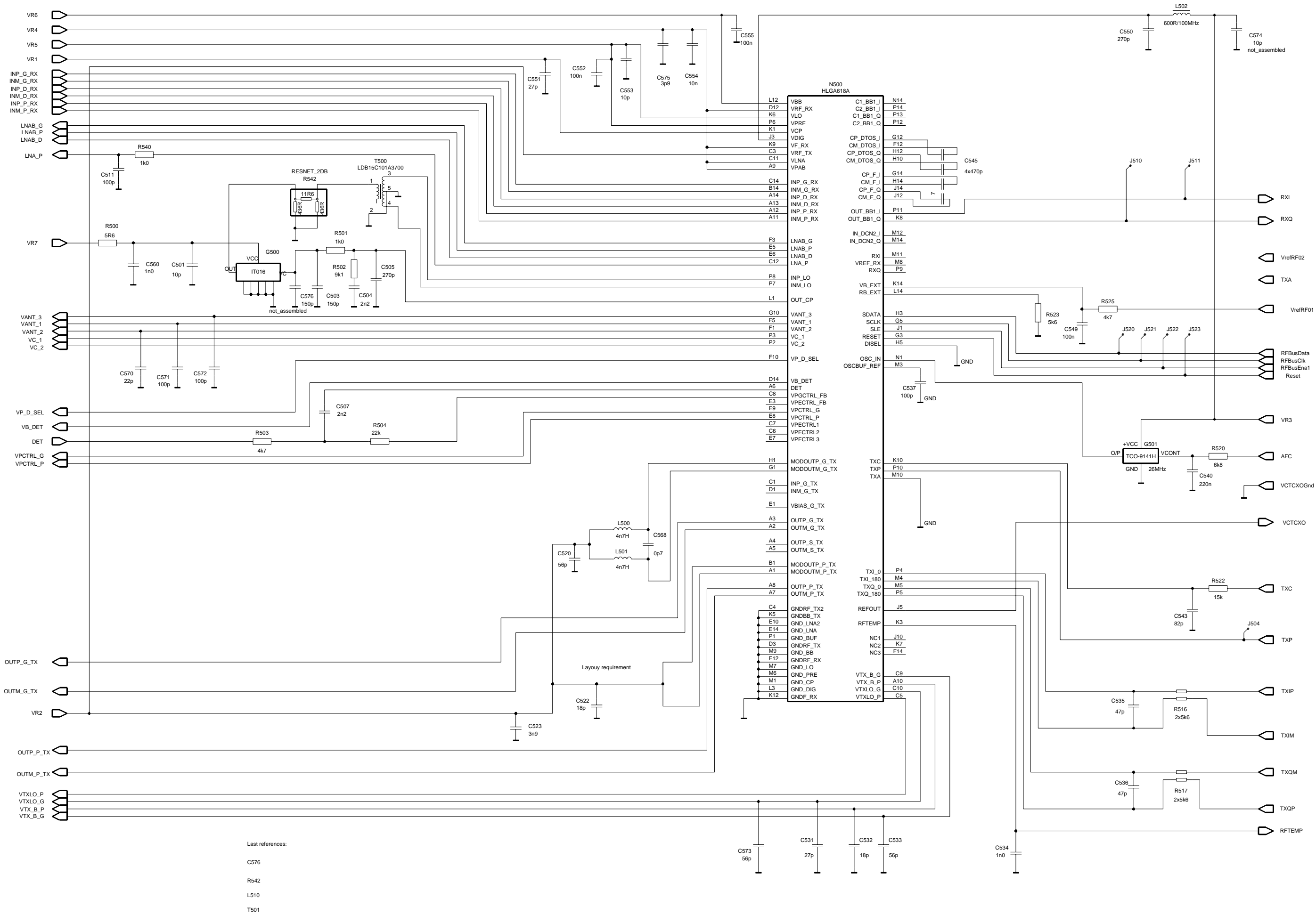

Last references:
 C576
 R542
 L510
 T501

RX Front End and Antenna Switch

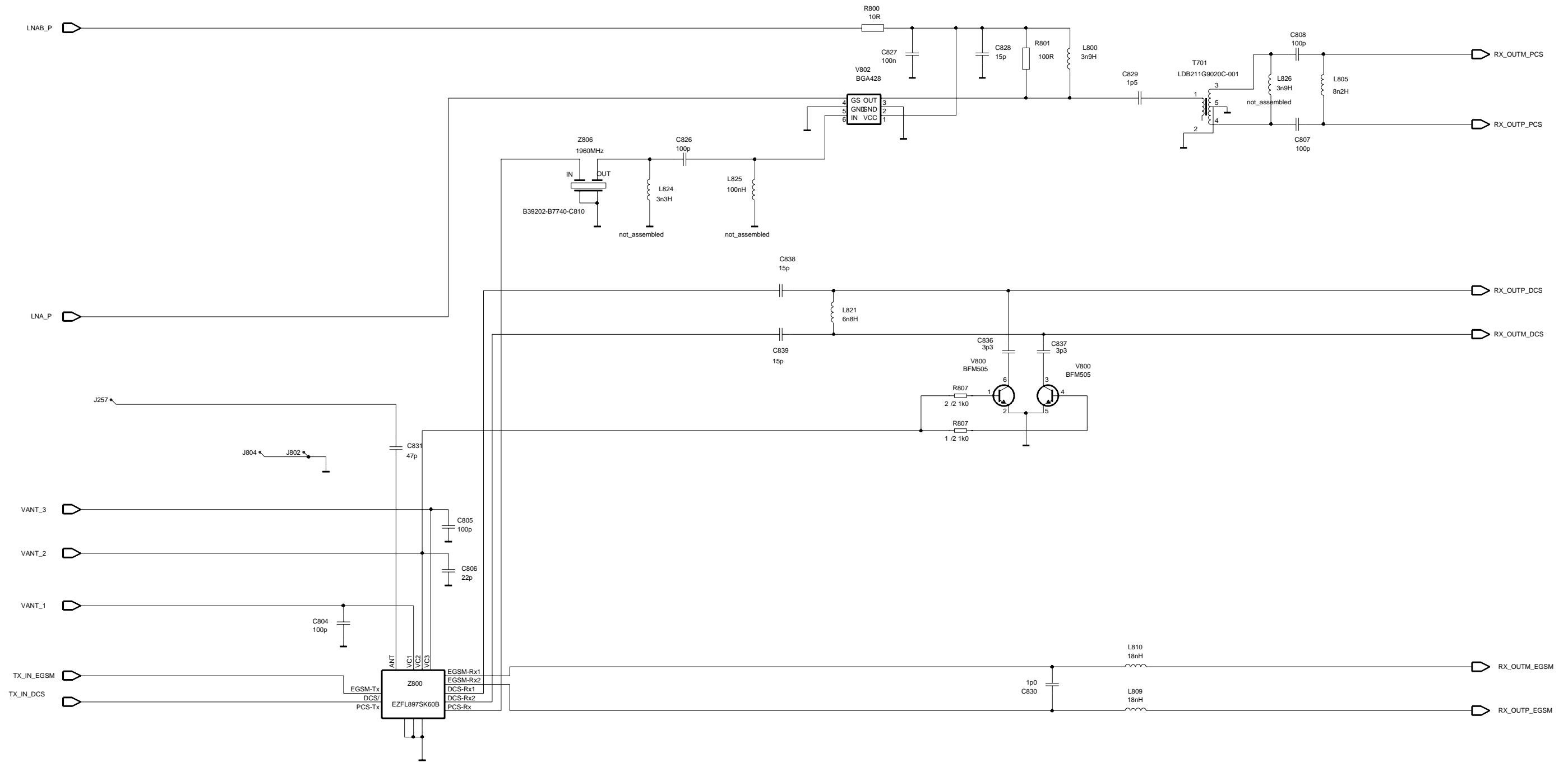

Last references:

C835

R807

L825

Assembly Values Diagram Bottom

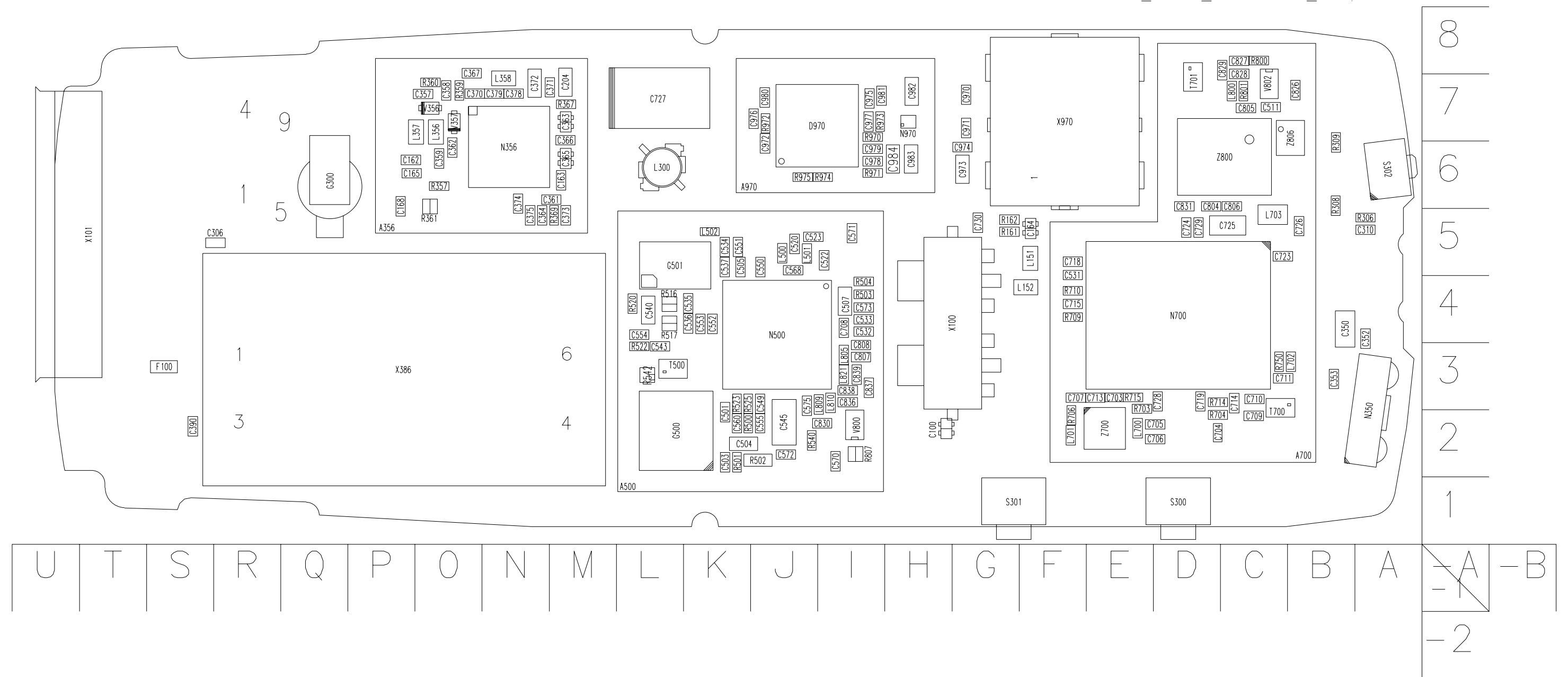

Assembly Values Diagram Top

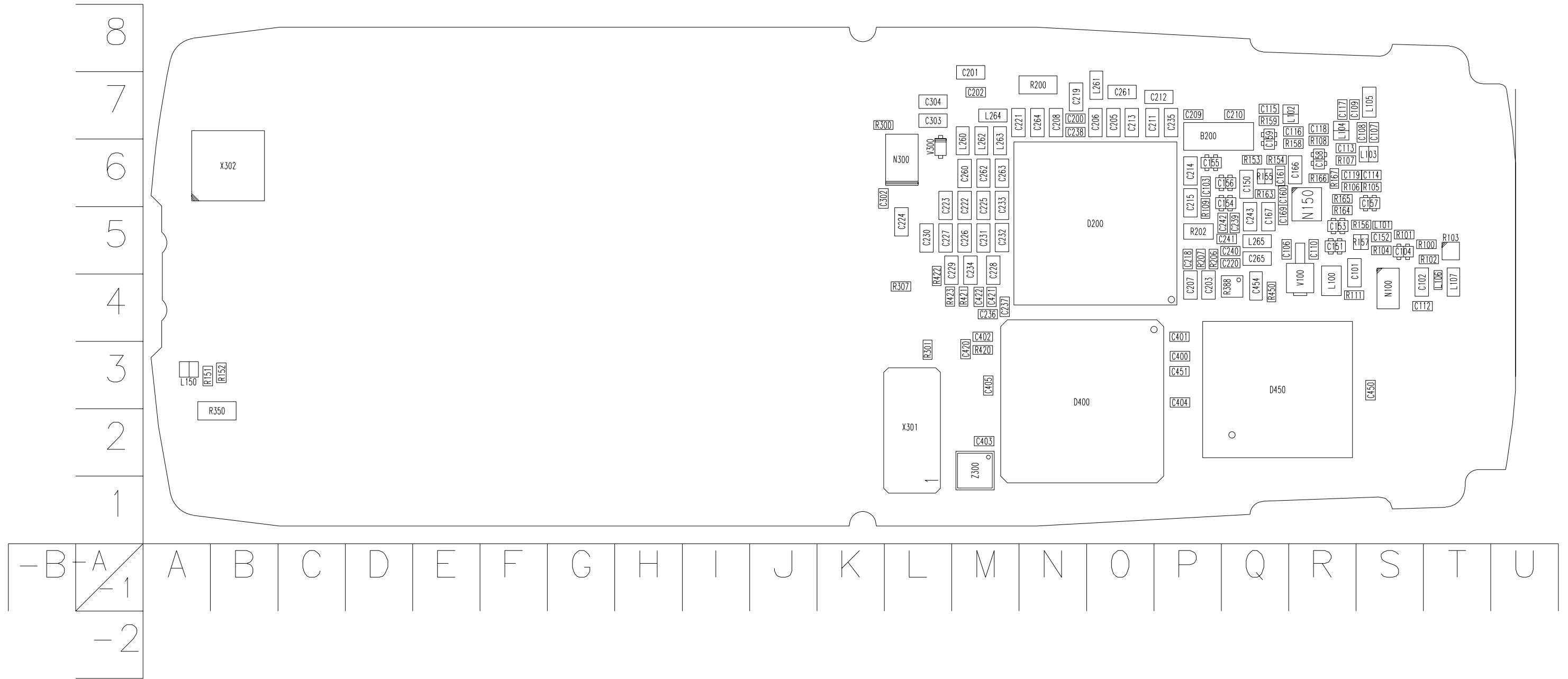

[This page intentionally blank]