

Telephone:
Fax:
VAT Registration No.:

Name:		Manufacturer:	Seat
Address:		Model:	Cordoba
		Year:	1993
		Registration:	
Tel - Private:		Mileage:	
Tel - Business:		Job number:	

X88	AC connector
31	Battery -
30	Battery +
S57	Closed throttle position (CTP) switch
B54	Crankshaft position (CKP) sensor
X1	Data link connector (DLC)
A35	Engine control module (ECM)
B24	Engine coolant temperature (ECT) sensor
Y104	Evaporative emission (EVAP) canister purge valve
M12	Fuel pump
K20	Fuel pump relay
F	Fuse
B72	Heated oxygen sensor (HO2S)
Y56	Idle speed control (ISC) actuator
A52	Ignition amplifier
T1	Ignition coil
15	Ignition switch - ignition ON
A162	Immobilizer control module
Y3	Injector
A5	Instrument panel - MIL light
A75	Instrumentation control module
B25	Intake air temperature (IAT) sensor
R9	Intake manifold heater
K23	Intake manifold heater relay
B72	Oxygen sensor (O2S)
B147	Throttle position (TP) sensor
A57	Transmission control module (TCM)

Manufacturer: Seat
Engine code: ABS
Tuned for: R-Cat

Model: Cordoba (93-99) 1,8
Output: 66 (90) 5500
Year: 1993-99

© Autodata Limited 2004
2009. 07. 02.
V5.373- ***Autodata***

B33	Vehicle speed sensor (VSS)
P9	Vehicle speedometer

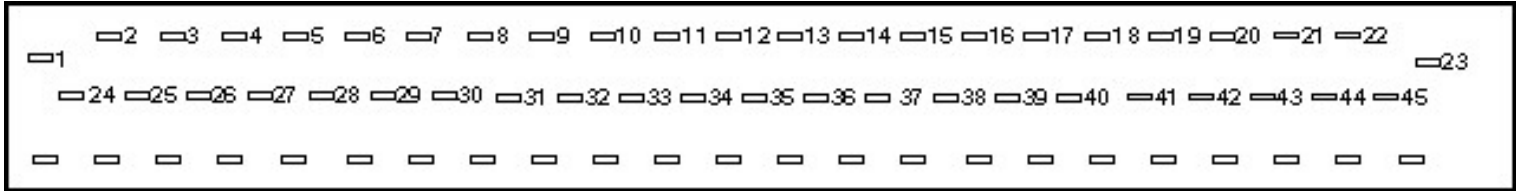

AD81645

bl = blue	br = brown	el = cream	ge = yellow
gn = green	gr = grey	nf = neutral	og = orange
rs = pink	rt = red	sw = black	vi = violet
ws = white	hbl = light blue	hgn = light green	rbr = maroon
x = braided cable	y = high tension	z = non-cable connection	

NOTE: In certain diagrams (Citroen, Peugeot & Renault), colour codes are replaced by numbers which are used to identify a particular cable and not the colour. In this instance, the cables will be numbered at each end close to the harness connector.

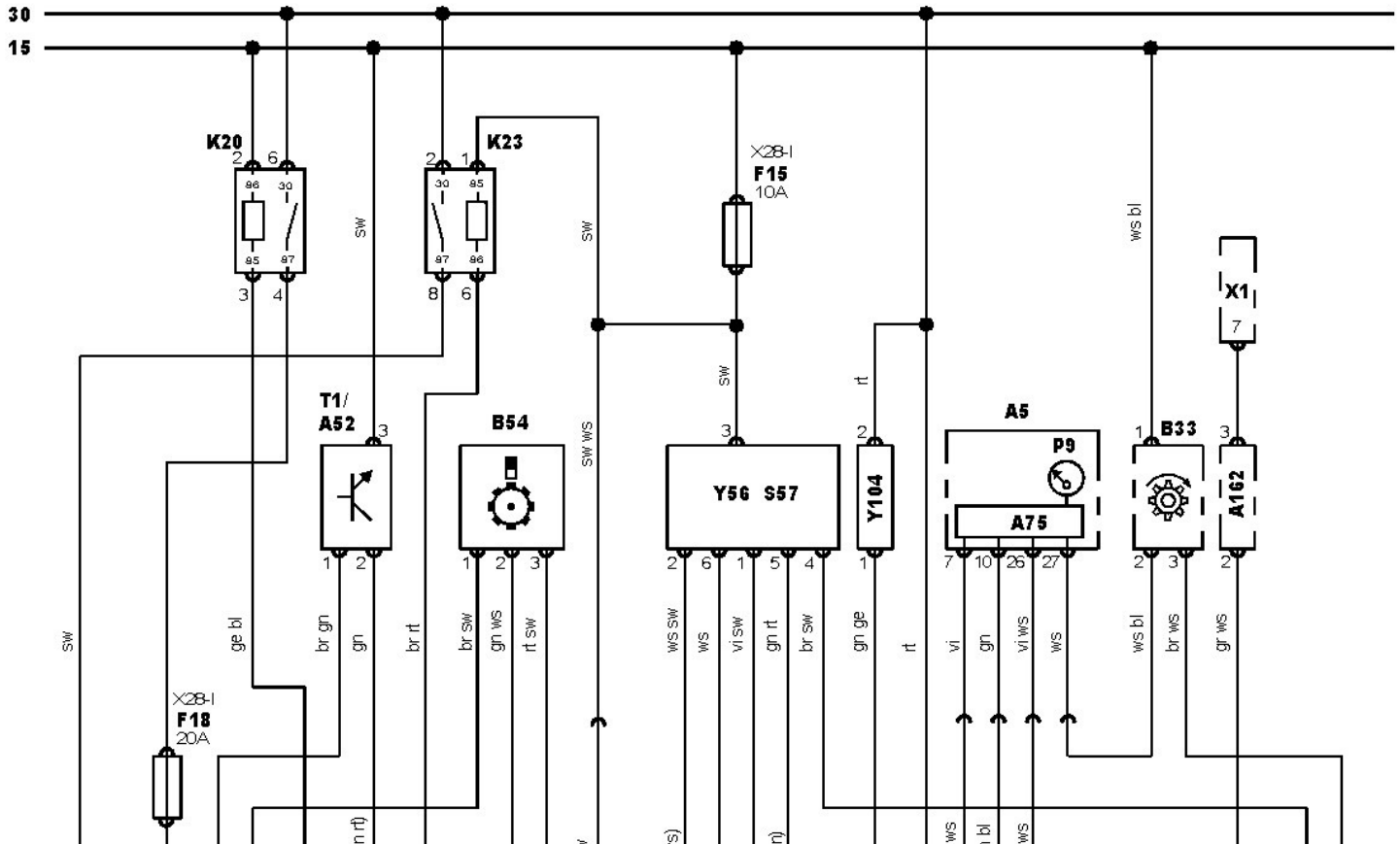

Manufacturer: Seat
 Engine code: ABS
 Tuned for: R-Cat

Model: Cordoba (93-99) 1,8
 Output: 66 (90) 5500
 Year: 1993-99

© Autodata Limited 2004

2009. 07. 02.

V5.373-

/Autodata

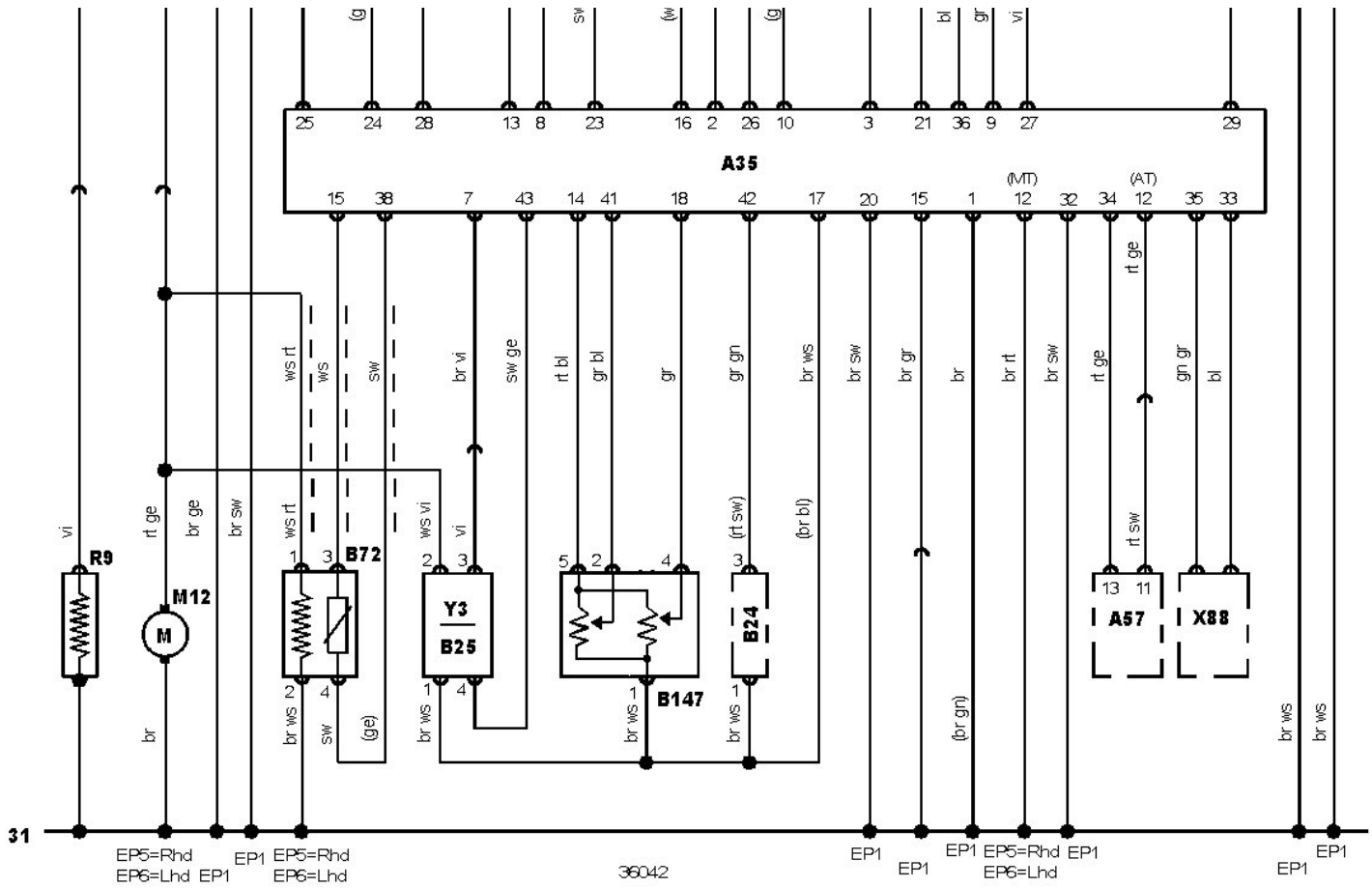

Manufacturer: Seat
 Engine code: ABS
 Tuned for: R-Cat

Model: Cordoba (93-99) 1,8
 Output: 66 (90) 5500
 Year: 1993-99

© Autodata Limited 2004
 2009. 07. 02.
 V5.373-
/Autodata