

XC6206 Series



Low ESR Cap. Compatible Positive Voltage Regulators

- ◆ CMOS Low Power Consumption
- ◆ Dropout Voltage : 160mV @ 100mA
: 400mV @ 200mA
- ◆ Output Current : More Than 250mA (5.0V type)
- ◆ Highly Accurate : $\pm 2\%$
- ◆ Output Voltage Range : 1.2V ~ 5.0V
- ◆ Low ESR Capacitor Compatible

GENERAL DESCRIPTION

The XC6206 series are highly precise, low power consumption, high voltage, positive voltage regulators manufactured using CMOS and laser trimming technologies. The series provides large currents with a significantly small dropout voltage.

The XC6206 consists of a current limiter circuit, a driver transistor, a precision reference voltage and an error correction circuit.

The series is compatible with low ESR ceramic capacitors. The current limiter's foldback circuit also operates as a short protect for the output current limiter and the output pin. Output voltage can be set internally by laser trimming technologies. It is selectable in 100mV increments within a range of 1.2V to 5.0V.

SOT-23, SOT-89, TO-92 and USP-6B packages are available.

TYPICAL APPLICATION CIRCUIT

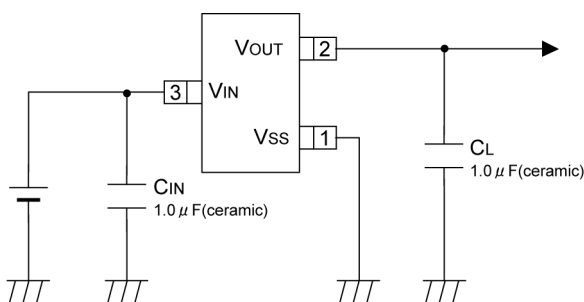

APPLICATIONS

- Battery powered equipment
- Reference voltage sources
- Cameras, video cameras
- Portable AV systems
- Mobile phones
- Portable games

FEATURES

- Maximum Output Current** : 250mA (5.0V type)
- Dropout Voltage** : 160mV @ I_{OUT}=100mA (5.0V type)
- Maximum Operating Voltage** : 6.0V
- Output Voltage Range** : 1.2V ~ 5.0V (100mV steps)
- Highly Accurate** : $\pm 2\%$
($\pm 30\text{mV}$ @ V_{OUT} < 1.5V)
($\pm 1\%$ @ V_{OUT} $\geq 2.0\text{V}$)
- Low Power Consumption** : 1.0 μA (TYP.)
- Operational Temperature Range** : -40°C ~ 85°C
- Ultra Small Package** : SOT-23, SOT-89, TO-92
USP-6B
- Low ESR Capacitor** : Ceramic capacitor compatible

TYPICAL PERFORMANCE CHARACTERISTICS

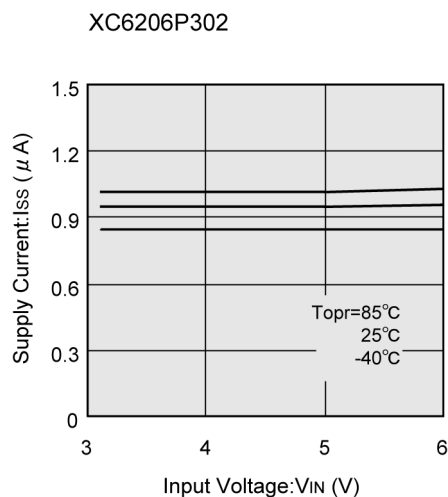

PIN CONFIGURATION

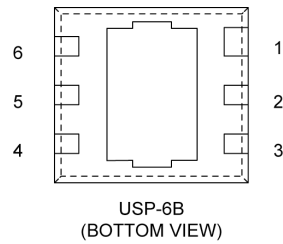
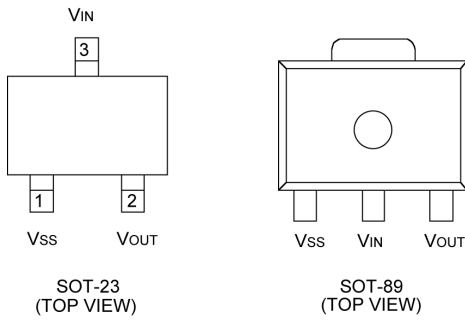

*The dissipation pad for the USP-6B package should be solder-plated in recommended mount pattern and metal masking so as to enhance mounting strength and heat release. If the pad needs to be connected to other pins, it should be connected to the VIN pin.

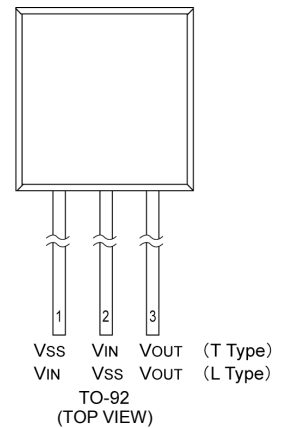

PIN ASSIGNMENT

PIN NUMBER				PIN NAME	FUNCTIONS
SOT-23	SOT-89/TO-92 (T)	USP-6B	TO-92 (L)		
1	1	2	2	VSS	Ground
3	2	4	1	VIN	Power Input
2	3	6	3	VOUT	Output
-	-	1, 3, 5	-	NC	No Connection

PRODUCT CLASSIFICATION

Ordering Information

XC6206P ①②③④⑤

DESIGNATOR	DESCRIPTION	SYMBOL	DESCRIPTION
①②	Output Voltage	12~50	: e.g. VOUT: 3.0V→①= 3, ② = 0
③	Accuracy	2	: Within $\pm 2\%$ (within $\pm 30\text{mV}$ when $V_{\text{OUT}} < 1.5\text{V}$)
		1 *	: Within $\pm 1\%$
④	Package	M	: SOT-23
		P	: SOT-89
		D	: USP-6B
		T	: TO-92 (Standard)
		L	: TO-92 (Custom pin configuration)
⑤	Device Orientation	R	: Embossed tape, standard feed
		L	: Embossed tape, reverse feed
		H	: Page type (TO-92)
		B	: Bag (TO-92)

* $\pm 1\%$ accuracy can be set at $V_{\text{OUT}(T)} \geq 2.0\text{V}$.

PACKAGING INFORMATION

● SOT-23

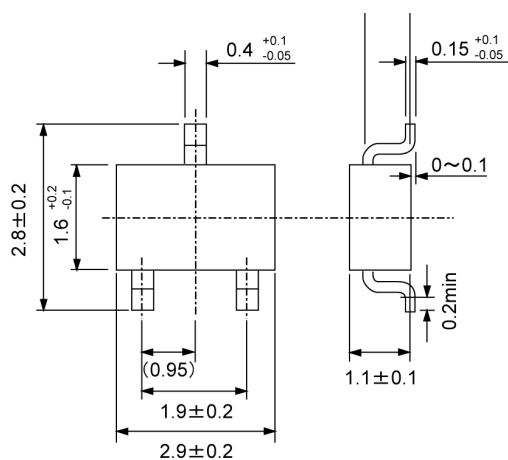

● SOT-89

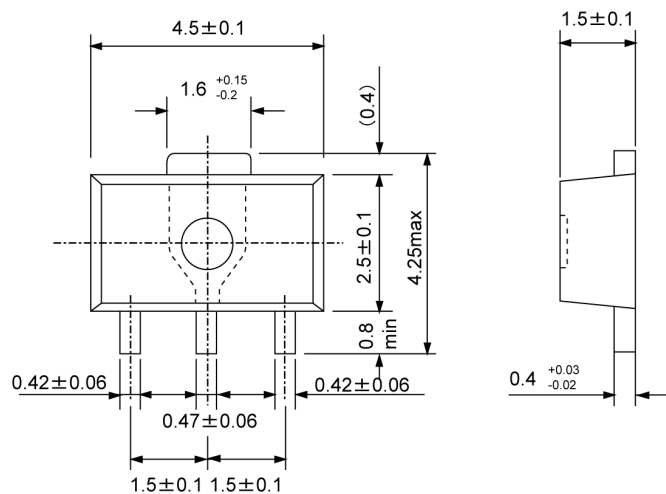

● USP-6B

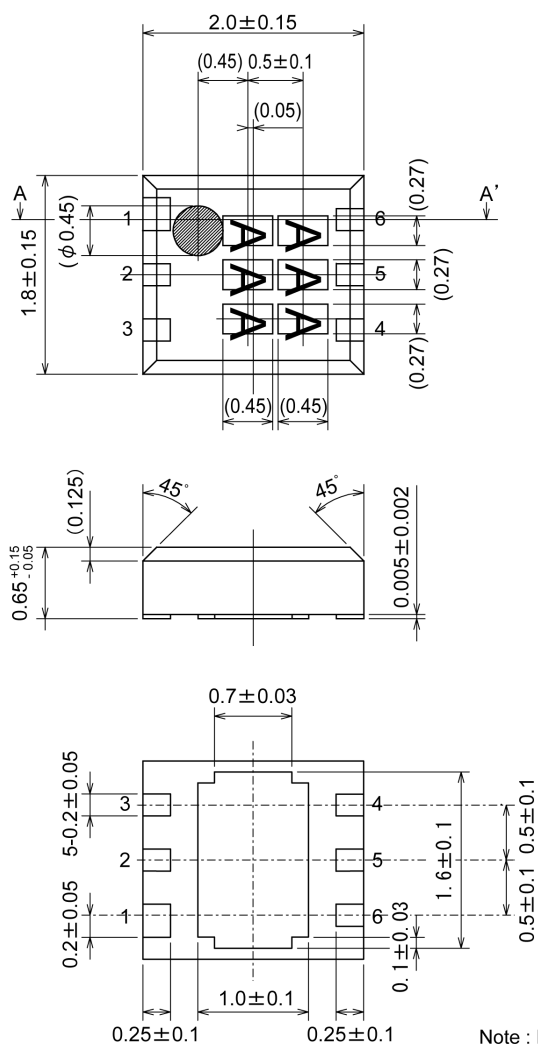

● TO-92

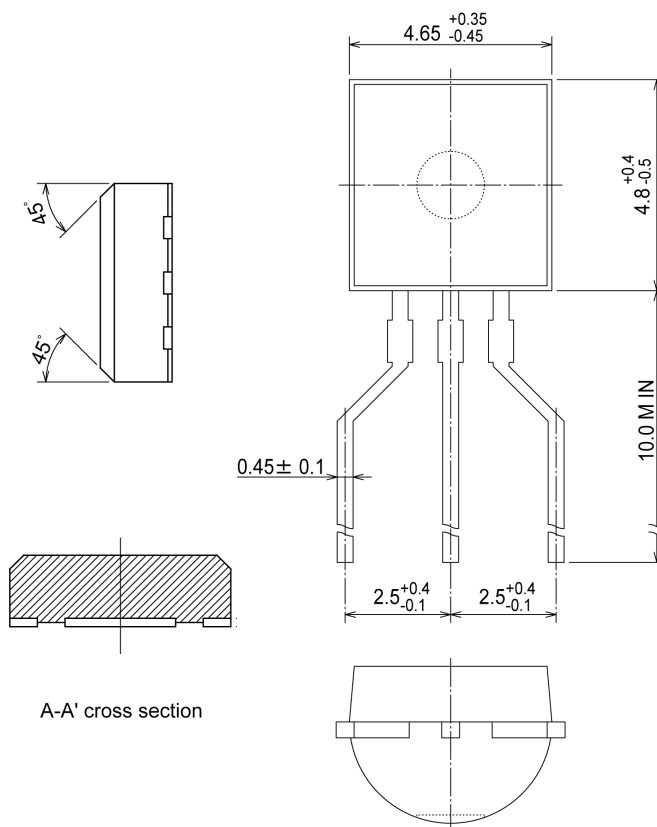

A-A' cross section

Note : Pin 1 is larger than the other pins.

MARKING RULE

● SOT-23 & SOT-89

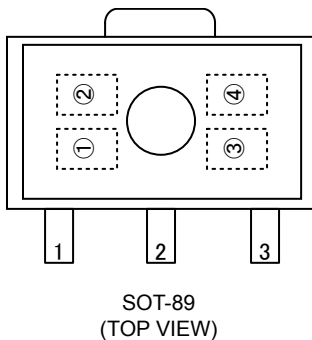
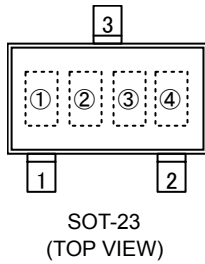

① Represents product series

MARK	PRODUCT SERIES
6	XC6206Pxxxxx

② Represents three pins regulator

MARK		PRODUCT SERIES
VOLTAGE: 0.1 ~ 3.0V	VOLTAGE: 3.1 ~ 6.0V	
5	6	XC6206Pxxxxx

③ Represents output voltage

MARK	OUTPUT VOLTAGE (V)		MARK	OUTPUT VOLTAGE (V)	
0	-	3.1	F	1.6	4.6
1	-	3.2	H	1.7	4.7
2	-	3.3	K	1.8	4.8
3	-	3.4	L	1.9	4.9
4	-	3.5	M	2.0	5.0
5	-	3.6	N	2.1	-
6	-	3.7	P	2.2	-
7	-	3.8	R	2.3	-
8	-	3.9	S	2.4	-
9	-	4.0	T	2.5	-
A	-	4.1	U	2.6	-
B	1.2	4.2	V	2.7	-
C	1.3	4.3	X	2.8	-
D	1.4	4.4	Y	2.9	-
E	1.5	4.5	Z	3.0	-

- ④ Represents production lot number
0 to 9, A to Z, reversed character of 0 to 9 and A to Z repeated.
(G, I, J, O, Q, W excepted)

● USP-6B

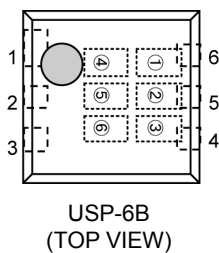

①② Represents product series

MARK		PRODUCT SERIES
①	②	
0	6	XC6206PxxxDx

③ Represents three pins regulator

MARK	TYPE	PRODUCT SERIES
P	Three pins regulator	XC6206PxxxDx

④⑤ Represents output voltage

MARK		OUTPUT VOLTAGE (V)	PRODUCT SERIES
①	②		
3	3	3.3	XC6206P33xDx
5	0	5.0	XC6206P50xDx

- ⑥ Represents production lot number
0 to 9, A to Z reversed (G, I, J, O, Q, W excepted)
* No character inversion used.

MARKING RULE (Continued)

TO-92

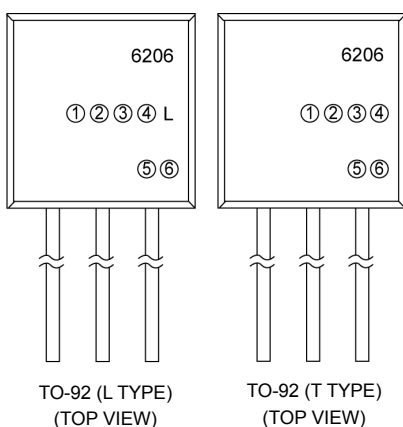

① Represents type of regulator

MARK	PRODUCT NAME
P	XC6206Pxxxxx

②③ Represents output voltage

MARK		VOLTAGE (V)	PRODUCT NAME
②	③		
3	3	3.3	XC6206P33xxx
5	0	3.3	XC6206P50xxx

④ Represents output voltage accuracy

MARK	OUTPUT VOLTAGE ACCURACY	PRODUCT NAME
1	within $\pm 1\%$	XC6206Pxx1xx
2	within $\pm 2\%$	XC6206Pxx2xx

⑤ Represents least significant digit of production year

MARK	PRODUCTION YEAR
3	2003
4	2004

⑥ Represents production lot number

0 to 9, A to Z repeated (G, I, J, O, Q, W excepted)

Note: No character inversion used.

BLOCK DIAGRAM

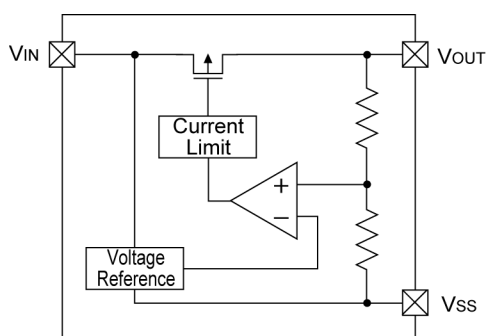

XC6206 Series

■ ABSOLUTE MAXIMUM RATINGS

Ta=25°C

PARAMETER		SYMBOL	RATINGS	UNITS
Input Voltage		V _{IN}	7.0	V
Output Current		I _{OUT}	500 *	mA
Output Voltage		V _{OUT}	V _{SS} - 0.3 ~ V _{IN} + 0.3	V
Power Dissipation	SOT-23	Pd	250	mW
	SOT-89		500	
	USP-6B		100	
	TO-92		300	
Operating Temperature Range		Topr	- 40 ~ + 85	°C
Storage Temperature Range		Tstg	- 55 ~ + 125	°C

* I_{OUT}=Pd / (V_{IN}-V_{OUT})

■ ELECTRICAL CHARACTERISTICS

●XC6206 series

Ta=25°C

PARAMETER	SYMBOL	CONDITIONS	MIN.	TYP.	MAX.	UNITS	CIRCUIT
Output Voltage (*7)	V _{OUT(E)}	I _{OUT} =30mA	x 0.98	V _{OUT(T)} E-1	x 1.02	V	①
Maximum Output Current	I _{OUTMAX}		-	-	E-2	mA	①
Load Regulation	ΔV _{OUT}	V _{OUT(T)} >1.8V, 1mA ≤ I _{OUT} ≤ 100mA V _{OUT(T)} ≤ 1.8V, 1mA ≤ I _{OUT} ≤ 50mA	-	-	E-3	mV	①
Dropout Voltage	V _{dif1}	I _{OUT} =30mA	-	E-4		mV	①
	V _{dif2}	V _{OUT(T)} >1.8V: I _{OUT} =100mA V _{OUT(T)} ≤ 1.8V: I _{OUT} =60mA	-	E-5		mV	
Supply Current	I _{DD}	V _{CE} =V _{IN}	-	1.0	3.0	μA	②
Line Regulation	$\frac{\Delta V_{OUT}}{\Delta V_{IN} \cdot V_{OUT}}$	V _{OUT(T)} <4.5V: V _{OUT(T)} +1.0V ≤ V _{IN} ≤ 6.0V V _{OUT(T)} ≥ 4.5V: 5.5V ≤ V _{IN} ≤ 6.0V I _{OUT} =30mA	-	0.05	0.25	%/V	①
Input Voltage	V _{IN}		1.8	-	6.0	V	-
Output Voltage Temperature Characteristics	$\frac{\Delta V_{OUT}}{\Delta T_{opr}} \cdot \frac{V_{OUT}}{V_{OUT}}$	I _{OUT} =30mA -40°C ≤ Topr ≤ 85°C	-	±100	-	ppm/ °C	①
Short Circuit Current	I _{short}	V _{IN} =V _{OUT} +1.5V, V _{OUT} =V _{SS}	-	E-6	-	mA	①

NOTE:

- * 1 : V_{OUT(T)} = Specified output voltage
- * 2 : V_{OUT(E)} = Effective output voltage (ie. The output voltage when "V_{OUT(T)}+1.0V" is provided at the V_{IN} pin while maintaining a certain I_{OUT} value.)
- * 3 : V_{dif} = {V_{IN} 1^(*) + V_{OUT} 1^(*)}
- * 4 : V_{OUT1} = A voltage equal to 98% of the output voltage whenever an amply stabilized I_{OUT} {V_{OUT(T)} + 1.0V} is input.
- * 5 : V_{IN} 1 = The input voltage when V_{OUT1} appears as input voltage is gradually decreased.
- * 6 : Unless otherwise stated, V_{IN} = V_{OUT(T)} + 1.0V
- * 7 : When V_{OUT(T)} ≥ 1.5V, accuracy is ±2%.
When V_{OUT(T)} < 1.5V, accuracy is MIN.: V_{OUT(T)} - 30mV / MAX.: V_{OUT(T)} + 30mV
+1% accuracy (MIN.: V_{OUT(T)} x 0.99 / MAX.: V_{OUT(T)} x 1.01) is set at V_{OUT(T)} ≥ 2.0V

■ ELECTRICAL CHARACTERISTICS (Continued)

● Electrical Characteristics Chart

PARAMETER SETTING VOLTAGE	E-1				E-2	E-3	E-4		E-5		E-6					
	OUTPUT VOLTAGE				MAX. OUTPUT CURRENT	LOAD REGULATION	DROPOUT VOLTAGE 1		DROPOUT VOLTAGE 2		SHORT CURRENT					
	2% ACCURACY		1% ACCURACY				Vdif1	Vdif2								
V _{OUT(T)}	V _{OUT(E)} (V)		V _{OUT(E)} (V)		I _{OUTMAX} (mA)	ΔV _{OUT}	Vdif1		Vdif2		I _{short}					
	MIN.	MAX.	MIN.	MAX.	MIN.	MAX.	TYP.	MAX.	TYP.	MAX.	TYP.					
1.2	1.170	1.230			60	40	460	760	700	960	180					
1.3	1.270	1.330					400	650								
1.4	1.370	1.430					350	590								
1.5	1.470	1.530				80	45	300	510	580	860	155				
1.6	1.568	1.632						250	450							
1.7	1.666	1.734						200	410							
1.8	1.764	1.836						150	390							
1.9	1.862	1.938			120	50	100	370	350	710	130					
2.0	1.960	2.040	1.980	2.020												
2.1	2.058	2.042	2.079	2.121												
2.2	2.156	2.244	2.178	2.222												
2.3	2.254	2.346	2.277	2.323												
2.4	2.352	2.448	2.376	2.424	150	55	75	350	250	680	100					
2.5	2.450	2.550	2.475	2.525												
2.6	2.548	2.652	2.574	2.626												
2.7	2.646	2.754	2.673	2.727												
2.8	2.744	2.856	2.772	2.828												
2.9	2.842	2.958	2.871	2.929												
3.0	2.940	3.060	2.970	3.030								200	60	60	320	200
3.1	3.038	3.162	3.069	3.131												
3.2	3.136	3.264	3.168	3.232												
3.3	3.234	3.366	3.267	3.333												
3.4	3.332	3.468	3.366	3.434												
3.5	3.430	3.570	3.465	3.535	70	75	350	250	680	100						
3.6	3.528	3.672	3.564	3.636												
3.7	3.626	3.774	3.663	3.737												
3.8	3.724	3.876	3.762	3.838												
3.9	3.822	3.978	3.861	3.939							250		70			
4.0	3.920	4.080	3.960	4.040												
4.1	4.018	4.182	4.059	4.141												
4.2	4.116	4.284	4.158	4.242												
4.3	4.214	4.386	4.257	4.343	75	75	320	200	630	100						
4.4	4.312	4.488	4.356	4.444												
4.5	4.410	4.590	4.455	4.545												
4.6	4.508	4.692	4.554	4.646												
4.7	4.606	4.794	4.653	4.747								80	50	290	175	600
4.8	4.704	4.896	4.752	4.848												
4.9	4.802	4.998	4.851	4.949												
5.0	4.900	5.100	4.950	5.050												

■ TEST CIRCUITS

Circuit ①

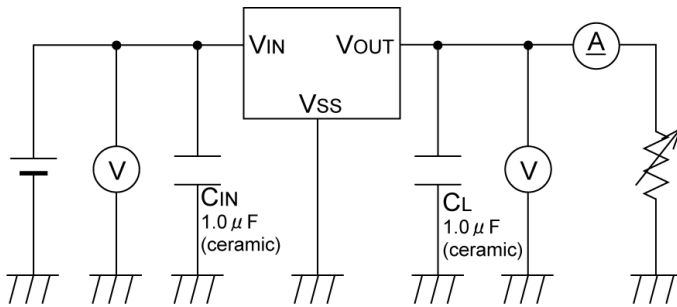

Circuit ②

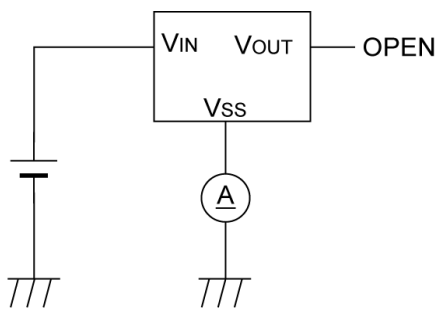

TYPICAL PERFORMANCE CHARACTERISTICS

(1) Output Voltage vs. Output Current

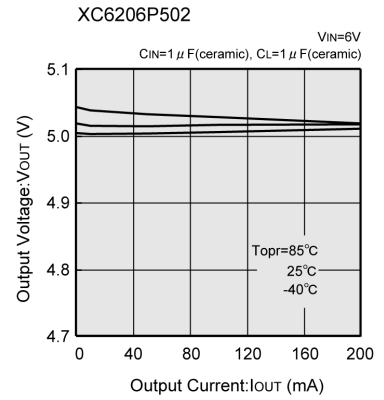
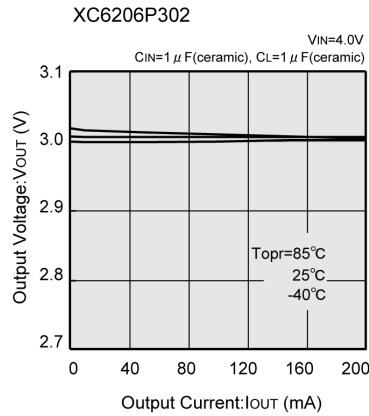
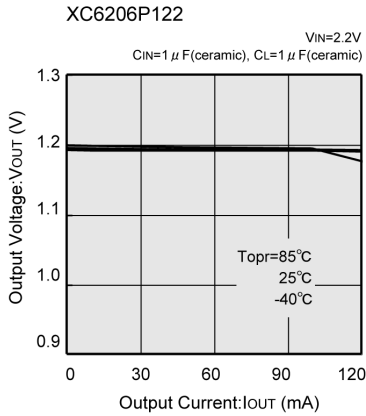

(2) Current Limit

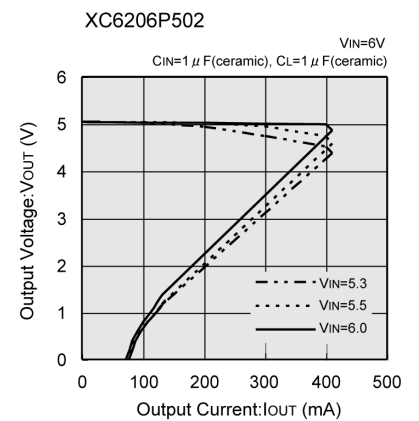
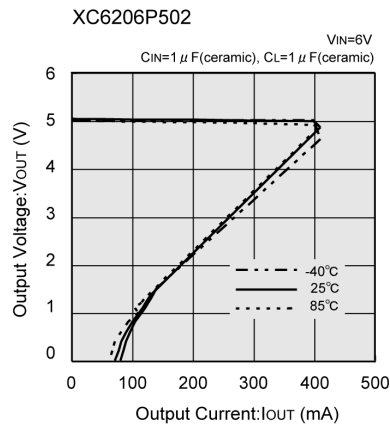
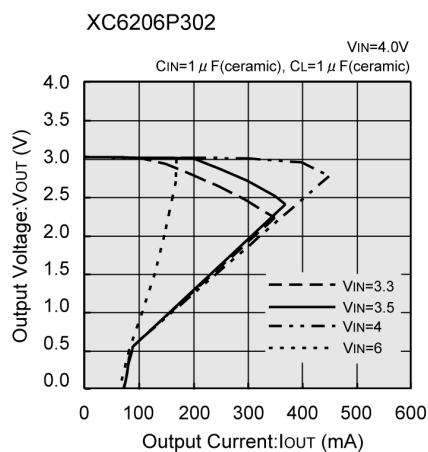
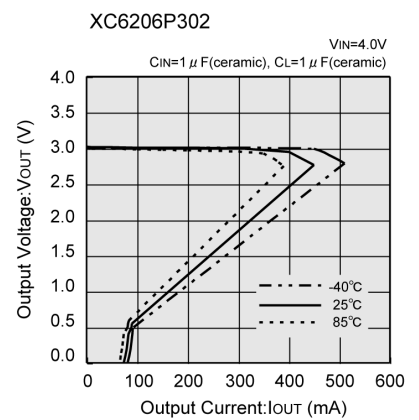
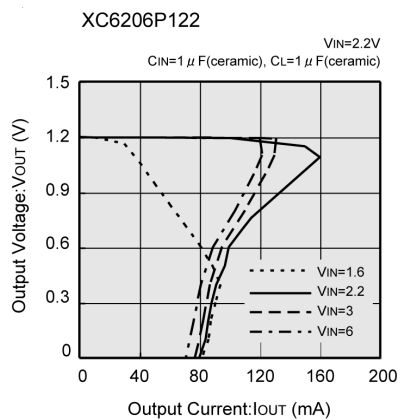
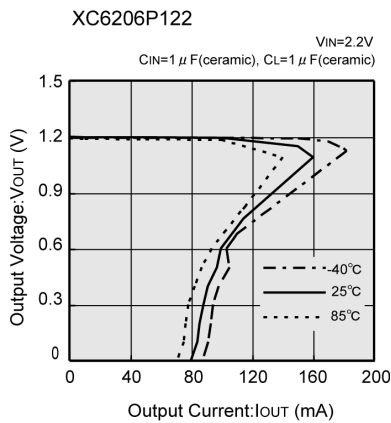

TYPICAL PERFORMANCE CHARACTERISTICS (Continued)

(3) Output Voltage vs. Input Voltage

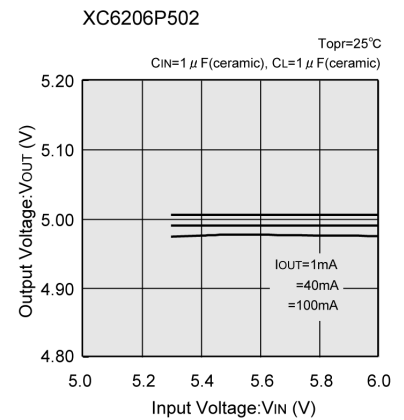
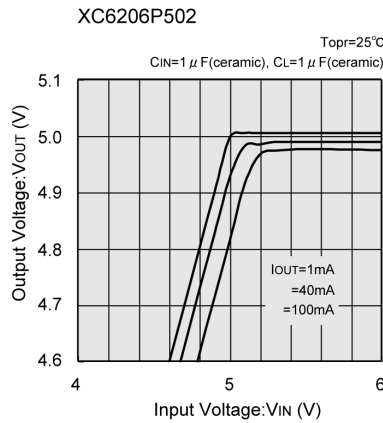
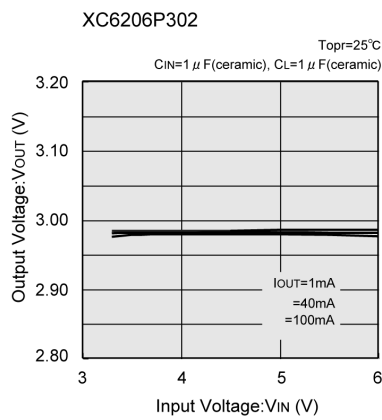
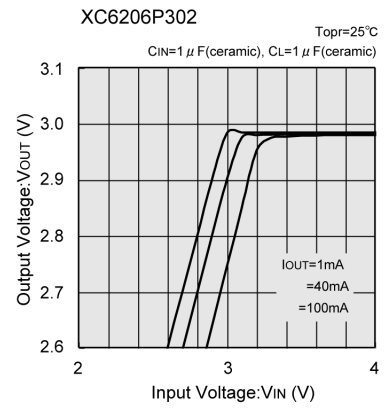
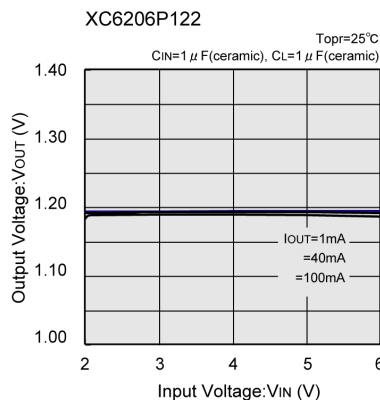
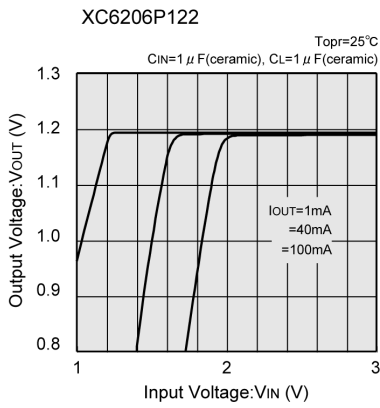

(4) Dropout Voltage vs. Output Current

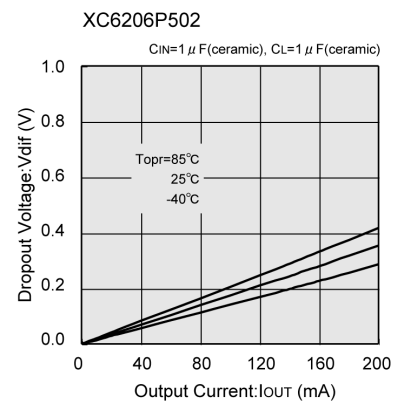
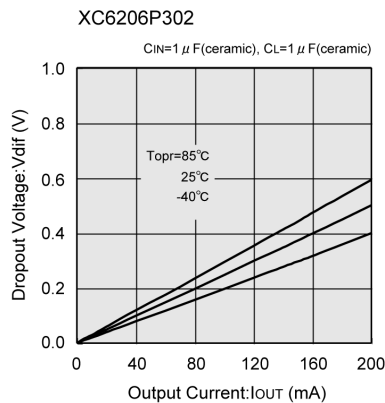
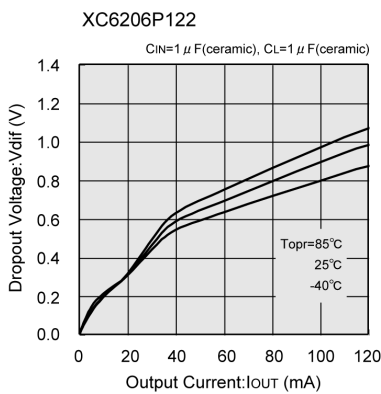

■ TYPICAL PERFORMANCE CHARACTERISTICS (Continued)

(5) Supply Current vs. Input Voltage

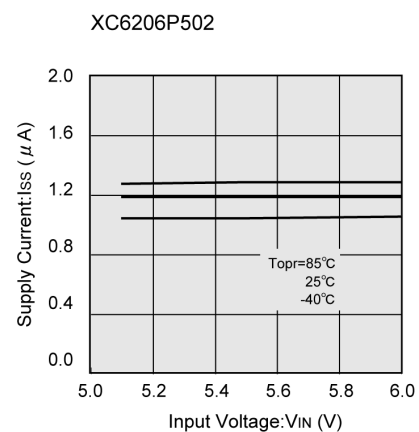
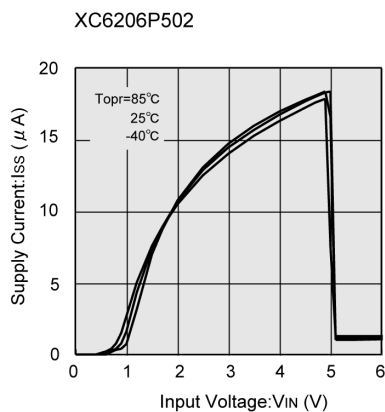
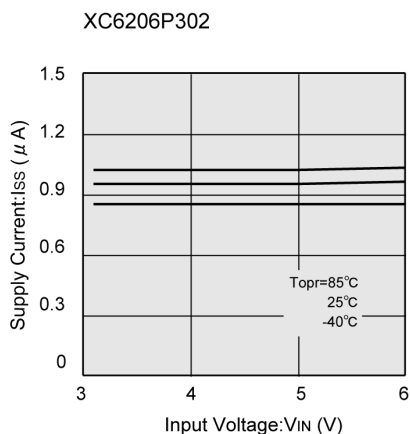
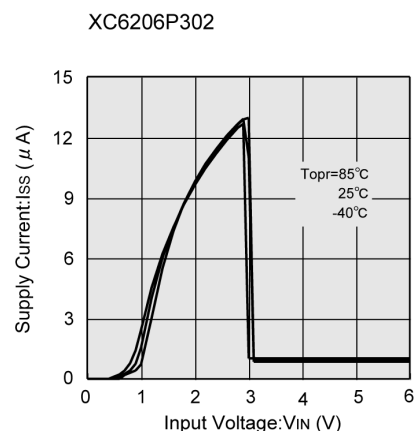
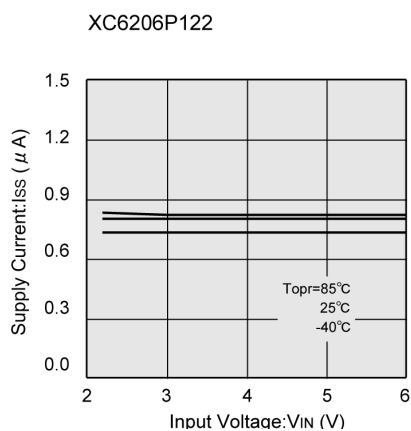
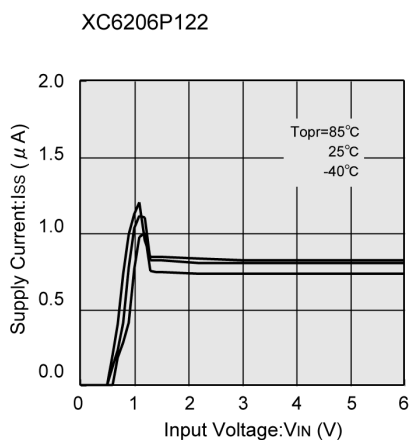

(6) Output Voltage vs. Ambient Temperature

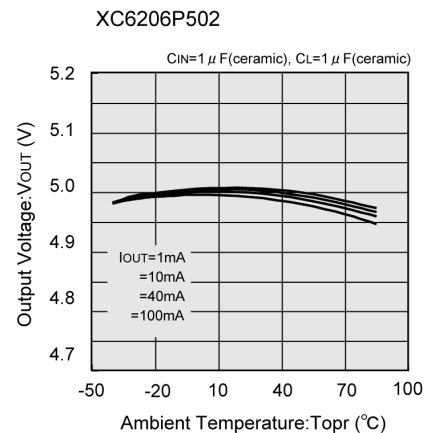
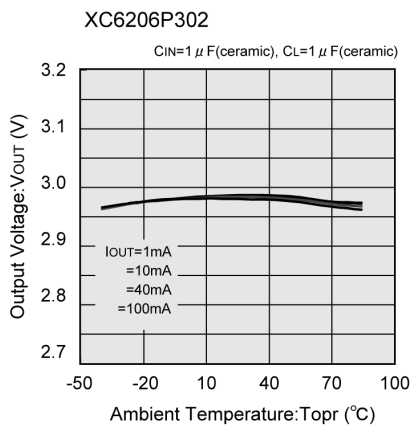
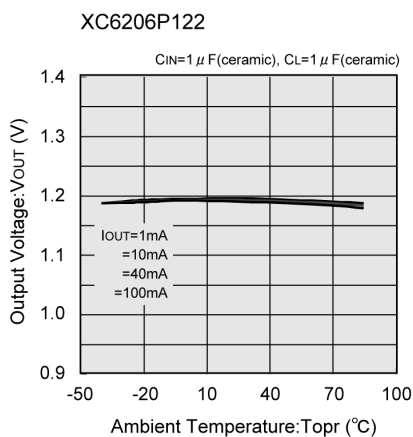

TYPICAL PERFORMANCE CHARACTERISTICS (Continued)

(7) Output Voltage vs. Ambient Temperature

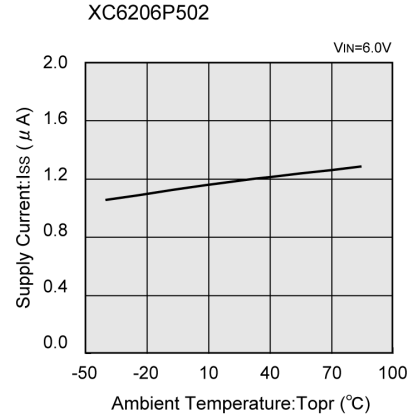
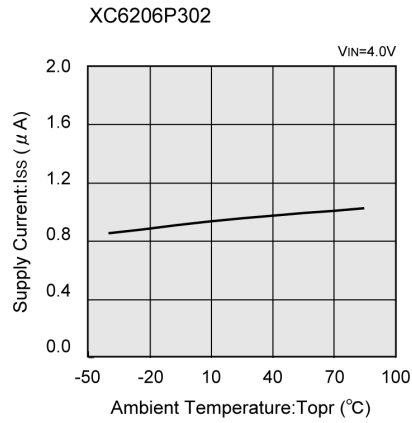
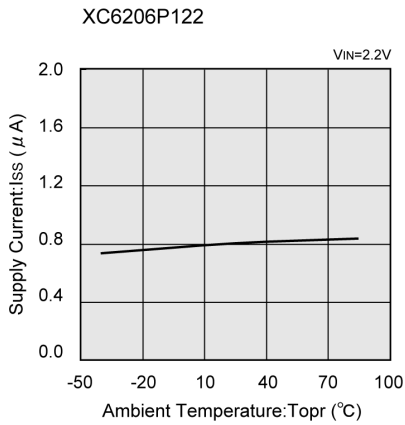

(8) Input Transient Response 1

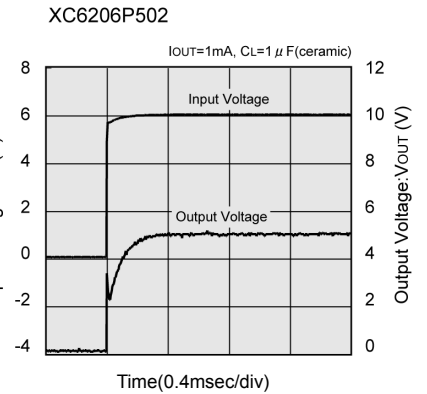
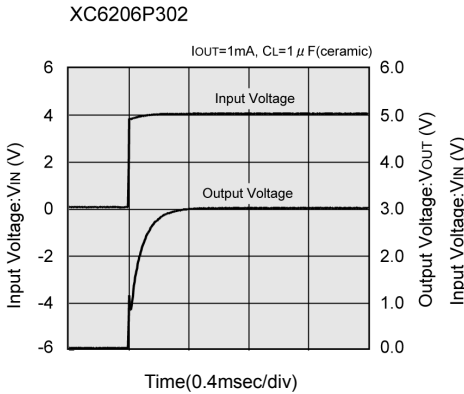
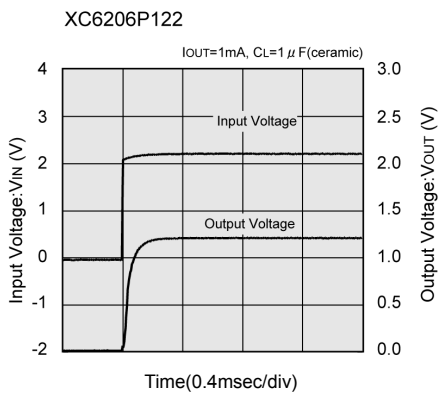
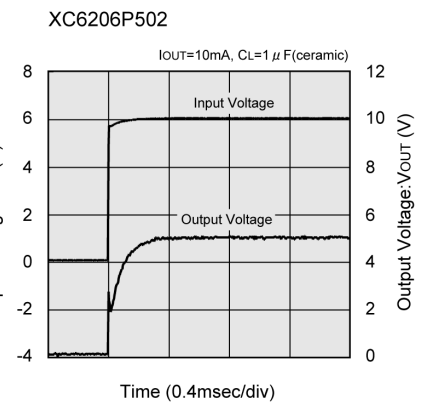
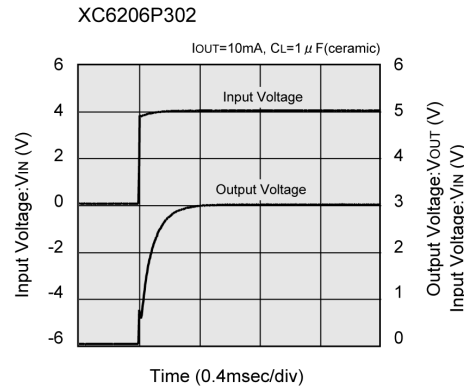
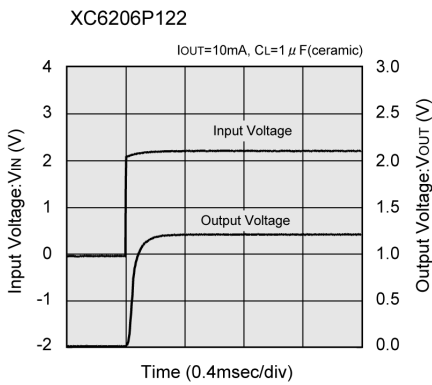

■ TYPICAL PERFORMANCE CHARACTERISTICS (Continued)

(9) Input Transient Response 2

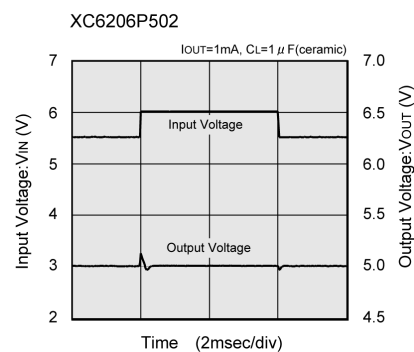
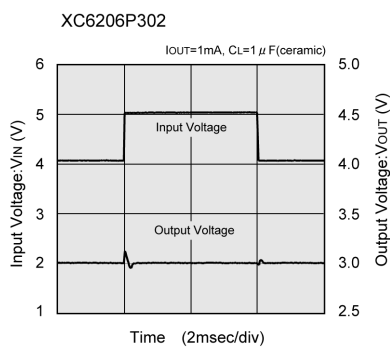
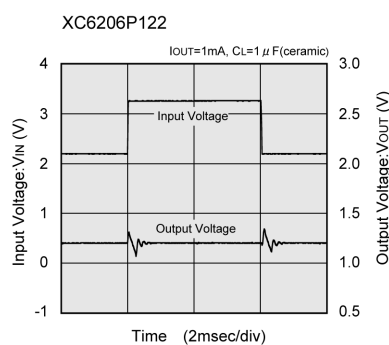
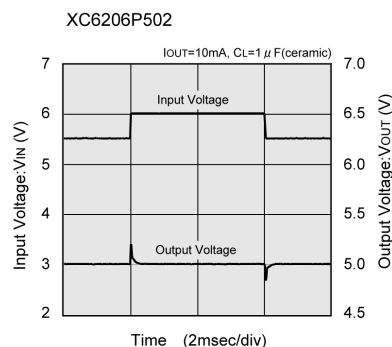
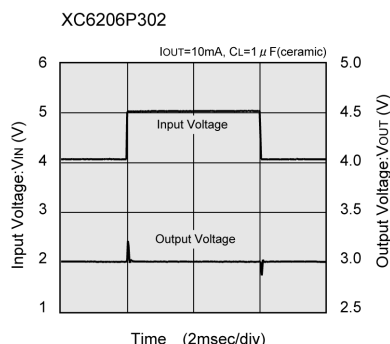
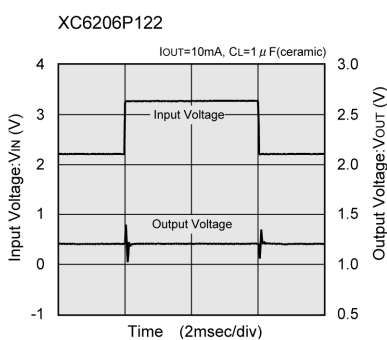

(10) Load Transient Response

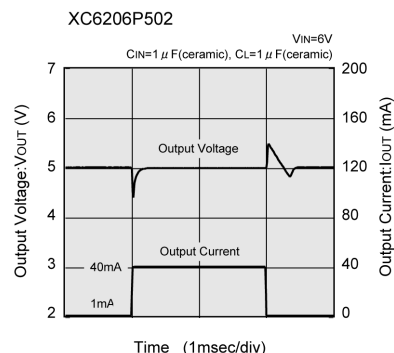
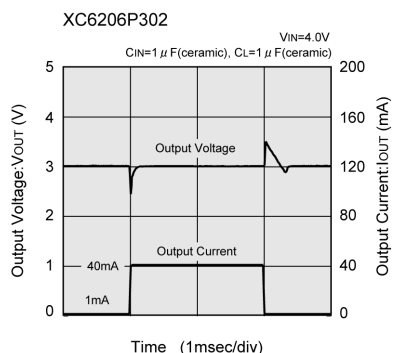
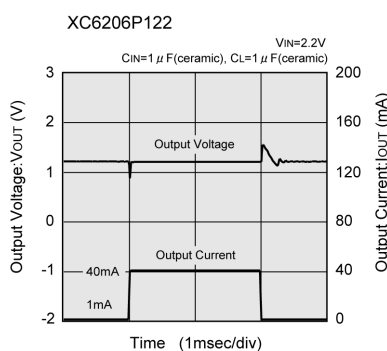

■ TYPICAL PERFORMANCE CHARACTERISTICS (Continued)

(11) Ripple Rejection Rate

