

EUROPEAN STANDARD

NORME EUROPÉENNE

EUROPÄISCHE NORM

FINAL DRAFT
prEN 50310

December 2004

ICS 33.100;35.020;91.140.50

Will supersede EN 50310:2000

English version

Application of equipotential bonding and earthing in buildings with information technology equipment

Application de liaison équipotentielle et de la mise à la terre dans les locaux avec équipement de technologie de l'information

Anwendung von Maßnahmen für Erdung und Potentialausgleich in Gebäuden mit Einrichtungen der Informationstechnik

This draft European Standard is submitted to CENELEC members for Unique Acceptance Procedure.
Deadline for CENELEC: 2005-06-10

It has been drawn up by Technical Committee CENELEC TC 215.

If this draft becomes a European Standard, CENELEC members are bound to comply with the CEN/CENELEC Internal Regulations which stipulate the conditions for giving this European Standard the status of a national standard without any alteration.

This draft European Standard was established by CENELEC in three official versions (English, French, German). A version in any other language made by translation under the responsibility of a CENELEC member into its own language and notified to the Central Secretariat has the same status as the official versions.

CENELEC members are the national electrotechnical committees of Austria, Belgium, Cyprus, Czech Republic, Denmark, Estonia, Finland, France, Germany, Greece, Hungary, Iceland, Ireland, Italy, Latvia, Lithuania, Luxembourg, Malta, Netherlands, Norway, Poland, Portugal, Slovakia, Slovenia, Spain, Sweden, Switzerland and United Kingdom.

Warning : This document is not a European Standard. It is distributed for review and comments. It is subject to change without notice and shall not be referred to as a European Standard.

CENELEC

European Committee for Electrotechnical Standardization
Comité Européen de Normalisation Electrotechnique
Europäisches Komitee für Elektrotechnische Normung

Central Secretariat: rue de Stassart 35, B - 1050 Brussels

Foreword

The first edition of this European Standard has been prepared by CENELEC/TC 215/WG 4, which was composed of experts of both CENELEC/TC 215 and ETSI/TC EE/WG EE 2 (former ETSI/STC EE 2). The second edition of this European Standard has been prepared by CENELEC/TC 215/WG 2. It is submitted to the Unique Acceptance Procedure.

This European Standard will supersede EN 50310:2000.

The following dates are proposed:

- | | | |
|--|-------|--|
| - latest date by which the existence of the EN has to be announced at national level | (doa) | dor + 6 months |
| - latest date by which the EN has to be implemented at national level by publication of an identical national standard or by endorsement | (dop) | dor + 12 months |
| - latest date by which the national standards conflicting with the EN have to be withdrawn | (dow) | dor + 36 months
(to be confirmed or modified when voting) |

This standard has been produced within the framework of the following considerations:

- a) With the ongoing growth of the liberalised telecommunication market, the increasing advent of private telecommunication network operators, and the flourishing use of networking computers, the amount of Information Technology equipment installed in buildings and the complexity of these Information Technology installations are permanently growing.
- b) Information Technology equipment is generally installed either as stand alone equipment (e. g. personal or network computers, small PBXs), or held in racks, cabinets or other mechanical structures (e. g. switching systems, transmission systems, mobile base stations).
- c) The existing ITU-T and ITU-R recommendations in such matters do not ensure the required standardisation at the equipment level.
- d) CENELEC/SC 64B „*Electrical installations of buildings: Protection against thermal effects*“ had decided during their meeting in November 1997 not to harmonize IEC 60364-5-548:1996 „*Electrical installations of buildings – Part 5: Selection and erection of electrical equipment – Section 548: Earthing arrangements and equipotential bonding for information technology installations*“.
- e) This European Standard shall give guidance to Network operators, equipment providers and building owners to agree on a standardised bonding configuration that facilitates:
 - compliance of the Information Technology Equipment installation with functional requirements including Electromagnetic Compatibility (EMC) aspects of emission and immunity;
 - compatible building installation and equipment provisions;
 - installation of new equipment in buildings as well as expansion or replacement of installations in existing buildings with equipment coming from different suppliers;
 - a structured installation practice;
 - simple maintenance rules;
 - contracting on a common basis;
 - harmonisation in development, manufacturing, installation and operation.

Content

Introduction	4
1 Scope	6
2 Normative references	6
3 Definitions, abbreviations and symbols	7
3.1 Definitions	7
3.2 Abbreviations	10
3.3 Symbols	11
4 General requirements	11
4.1 Safety from electrical hazards.....	11
4.2 Signal reference	11
4.3 Electromagnetic compatibility (EMC).....	11
5 Requirements on bonding networks	11
5.1 Bonding configurations.....	11
5.2 Common bonding network (CBN) within a building	12
5.3 Bonding network (BN) within an information technology system.....	13
5.4 Merging of common bonding network (CBN) and meshed bonding network (MESH-BN).....	13
5.5 Bonding and routing aspects of cabling within and between bonding networks.....	13
5.6 Indication of equipotential bonding conductors.....	16
6 Requirements for electricity distribution system	16
6.1 DC distribution system of secondary supply	16
6.2 DC distribution system of tertiary supply.....	16
6.3 AC distribution system and bonding of the protective conductor.....	16
6.4 AC distribution system from tertiary power supply.....	17
Annex A (normative) Special national conditions	22
Annex B (informative) Rationale about common bonding network (CBN) co-ordination ...	22
Annex C (informative) Rationale for the integration of DC distribution systems into the merging of common bonding network (CBN) and meshed bonding network (MESH-BN)	23
Bibliography	24

Introduction

This standard addresses earthing and bonding of information technology equipment in buildings in relation to safety, functional and electromagnetic performance, taking into account that the draft does not specify another earthing and bonding system but selects out of the existing ones (specified in HD 384 series together with IEC 60364-5-548) the best suitable system to information technology needs (CBN, MESH-BN, TN-S system).

Information regarding the general principles on earthing for (small) telecommunication installations in buildings has been published in Recommendation ITU-T K.31.

Depending on the degree of complexity and the size of the information technology installation, different levels of earthing and bonding are required. Starting from basic requirements on earthing and bonding this standard defines the refinements necessary to operate information technology equipment. The underlined concepts of this standard are in harmony with EN 300253. Therefore large information technology installations in buildings, which may require special care to avoid damage or upset from electromagnetic sources can make use of the bonding configurations and earthing techniques of EN 300253.

The specifications of EN 50310 are intended to provide optimum earthing and bonding conditions for buildings, where information technology installations are to be operated. EN 50310 should be applied at least in the case of newly constructed buildings and whenever possible in existing buildings (e. g. on the occasion of refurbishment). EN 50174-2 details the considerations for satisfactory installation and operation of information technology cabling within the environment of a building operating a low-voltage electricity distribution system (up to AC 1000 V rms). EN 50174-2 therefore refers, among others, to the requirements of EN 50310. For the relationship of EN 50310 and European standards on information technology cabling and their usage see Table 1.

Table 1 - Relationship between EN 50310 and European Standards dealing with information technology cabling

Building design phase	Cabling design phase	Planning phase	Implementation phase	Operation phase
<p>EN 50310</p> <p>5.2: Common bonding network (CBN) within a building</p> <p>6.3: AC distribution system and bonding of the protective conductor (TN-S)</p>	<p>Series EN 50173</p> <p>or (and)</p> <p>EN 50098-1</p> <p>or (and)</p> <p>EN 50098-2</p> <p>or (and)</p> <p>Other application standards</p>	<p>EN 50174-1</p> <p>4: Specification considerations</p> <p>5: Quality assurance</p> <p>7: Cabling administration</p> <p>and</p> <p>EN 50174-2</p> <p>4: Safety requirements</p> <p>5: General installation practices for metallic and optical fibre cabling</p> <p>6: Additional installation practice for metallic cabling</p> <p>7: Additional installation practice for optical fibre cabling</p> <p>and</p> <p>EN 50174-3</p> <p>and</p> <p>(for equipotential bonding)</p> <p>EN 50310</p> <p>5.2: Common bonding network (CBN) within a building</p> <p>6.3: AC distribution system and bonding of the protective conductor (TN-S)</p>	<p>EN 50174-1</p> <p>6: Documentation</p> <p>7: Cabling administration</p> <p>and</p> <p>EN 50174-2</p> <p>4: Safety requirements</p> <p>5: General installation practices for metallic and optical fibre cabling</p> <p>6: Additional installation practice for metallic cabling</p> <p>7: Additional installation practice for optical fibre cabling</p> <p>and</p> <p>EN 50174-3</p> <p>and</p> <p>(for equipotential bonding)</p> <p>EN 50310</p> <p>5.2: Common bonding network (CBN) within a building</p> <p>6.3: AC distribution system and bonding of the protective conductor (TN-S)</p> <p>and</p> <p>EN 50346</p> <p>4: General requirements</p> <p>5: Test parameters for balanced cabling</p> <p>6: Test parameters for optical fibre cabling</p>	<p>EN 50174-1</p> <p>5: Quality assurance</p> <p>7: Cabling administration</p> <p>8: Repair and maintenance</p>

1 Scope

1.1 This European Standard applies to the equipotential bonding inside buildings in which information technology equipment is going to be installed. It contributes to the standardisation of information technology equipment and co-ordinates with the pre-requirements of the generic installation conditions as outlined in IEC 60364-5-548 to achieve the following targets:

- a) safety from electrical hazards;
- b) reliable signal reference within the entire information technology installation;
- c) satisfactory electromagnetic performance of the entire information technology installation.

1.2 A defined bonding configuration down to the equipment level – independent of the equipment supplier – is intended to facilitate

- the installation, operation and maintenance of information technology installations in buildings;
- the interworking between different information technology equipment (interconnected by metallic links).

The specification of information technology equipment and of the pre-requirements of installation are subject to agreement of the parties (e. g. the equipment supplier and the purchaser or building owner).

1.3 This standard applies to buildings with information technology equipment or in which the installation of information technology equipment is intended. It provides additional information for architects of buildings and for designers and installers of electrical installations of buildings on some installation concepts that limit electromagnetic influences. Basic considerations are given here to mitigate such influences that may result in disturbance. This standard does not apply to buildings which may be subject to a harsh electromagnetic environment, or rooms containing the generation, transmission or termination of voltages over AC 1000 V. This standard does not address the specific requirements for telecommunication centres; these are specified in EN 300253.

2 Normative references

The following referenced documents are indispensable for the application of this document. For dated references, only the edition cited applies. For undated references, the latest edition of the referenced document (including any amendments) applies.

EN 41003, *Particular safety requirements for equipment to be connected to telecommunication networks*

EN 50083 (series), *Cable networks for television signals, sound signals and interactive services* 1), 2)

EN 50174-2, *Information technology – Cabling installation – Part 2: Installation planning and practices inside buildings*

EN 60079-14, *Electrical apparatus for explosive gas atmospheres – Part 14: Electrical installations in hazardous areas (other than mines) IEC 60079-14:2002)*

EN 60446, *Basic and safety principles for man-machine interface, marking and identification - Identification of conductors by colours or numerals (IEC 60446:1999)*

EN 60950-1, *Information technology equipment – Safety – Part 1: General requirements (IEC 60950-1:2001, modified)*

1) Antenna systems are included in the scope of the EN 50083 series.

2) EN 50083 series will be gradually transformed into EN 60728 series.

EN 61140, *Protection against electric shock – Common aspects for installation and equipment (IEC 61140:2001)*

EN 300253, *Environmental Engineering (EE) – Earthing and bonding configuration inside telecommunication centres*

HD 384.3 S2, *Electrical installations of buildings – Part 3: Assessment of general characteristics of installations (IEC 60364-3:1993, modified)*

HD 384.4.41 S2, *Electrical installations of buildings – Part 4: Protection for safety – Chapter 41: Protection against electric shock (IEC 60364-4-41:1992, modified)*

HD 384.5.54 S1 ³⁾, *Electrical installations of buildings – Part 5: Selection and erection of electrical equipment – Chapter 54: Earthing arrangements and protective conductors (IEC 60364-5-54:1980, modified)*

IEC 61024 (series), *Protection of structures against lightning*

IEC 61312 (series), *Protection against lightning electromagnetic impulse*

3 Definitions, abbreviations and symbols

3.1 Definitions

For the purposes of this document, the following terms and definitions apply.

NOTE 1 The definitions with respect to earthing and bonding are taken from series IEC 60050. Furthermore, definitions specific to information technology installations given in EN 300253:2002 are used. Reference to these standards is indicated, where appropriate, in square brackets. These definitions are reproduced here to assist the reader of this standard.

NOTE 2 The concept of the various electricity distribution systems (TN-S, TN-C, TT and IT) is introduced in detail in HD 384.3 S2.

3.1.1

bonding mat

essential means to provide a SRPP by a discernible, nearly regular mesh structure

NOTE The bonding mat may be located either below or above a collection of equipment constituting a system block.

[EN 300253:2002, 3.1.2]

3.1.2

bonding network

BN (abbreviation)

set of interconnected conductive structures that provides an „electromagnetic shield“ for electronic systems and personnel at frequencies from direct current (DC) to low radio frequency (RF).

NOTE The term „electromagnetic shield“ denotes any structure used to divert, block or impede the passage of electromagnetic energy. In general, a BN need not be connected to earth but all BNs considered in the present document will have an earth connection.

[EN 300253:2002, 3.1.2]

3.1.3

bonding ring conductor

BRC (abbreviation)

an earthing bus conductor which forms a closed connected ring. Normally a BRC has multiple connections to the CBN and therefore improves its quality

3) Intended to be superseded by HD 60364-5-54 (at present in enquiry stage).

3.1.4

common bonding network

CBN (abbreviation)

principal means for effective bonding and earthing inside a building with information technology equipment.

NOTE It is the set of metallic components that are intentionally or incidentally interconnected to form the principal BN in a building. These components include: structural steel or reinforcing rods, metallic plumbing, alternating current (AC) power conduit, protective conductors (PE), cable racks and bonding conductors. The CBN is connected to the earthing network.

[EN 300253:2002, 3.1.2 MOD]

3.1.5

DC return conductor

(+) conductor of the –48 V or –60 V secondary DC supply

[EN 300253:2002, 3.1.2]

3.1.6

(local) earth

part of the Earth which is in electric contact with an earth electrode and whose electric potential is not necessarily equal to zero

[IEC 60050-826:2004, 826-13-02; IEC 60050-195:1998, 195-01-03]

NOTE The concept „Earth“ means the planet and all its physical matter.

3.1.7

earth electrode

conductive part, which may be embedded in the soil or in a specific conductive medium, e. g. concrete or coke, in electric contact with Earth

[IEC 60050-826:2004, 826-13-05; IEC 60050-195:1998, 195-02-01 MOD]

3.1.8

earthing conductor

conductor which provides a conductive path, or part of the conductive path, between a given point in a system or in an installation or in equipment and an earth electrode or an earth-electrode network

[IEC 60050-826:2004, 826-13-12; IEC 60050-195:1998, 195-02-03 MOD]

3.1.9

earth-electrode network

part of an earthing arrangement comprising only the earth electrodes and their interconnections

[IEC 60050-826:2004, 826-13-06; IEC 60050-195:1998, 195-02-21]

3.1.10

equipotential bonding

provisions of electric connections between conductive parts, intended to achieve equipotentiality

[IEC 60050-826:2004, 826-13-19; IEC 60050-195:1998, 195-01-10]

3.1.11

protective bonding conductor

protective conductor provided for protective-equipotential-bonding

[IEC 60050-826:2004, 826-13-24; IEC 60050-195:1998, 195-02-10]

3.1.12**main earthing terminal
main earthing busbar**

terminal or busbar which is part of the earthing arrangement of an installation and enabling the electric connection of a number of conductors for earthing purposes

[IEC 60050-826:2004, 826-13-15; IEC 60050-195:1998, 195-02-33]

NOTE Abbreviation: MET

3.1.13**meshed bonding network
MESH-BN** (abbreviation)

bonding network in which all associated equipment frames, racks and cabinets and usually the DC power return conductor, are bonded together as well as at multiple points to the CBN

NOTE Consequently, the MESH-BN augments the CBN.

[EN 300253:2002, 3.1.2]

3.1.14**neutral conductor**

conductor electrically connected to the neutral point and capable of contributing to the distribution of electric energy

[IEC 60050-826:2004, 826-14-07; IEC 60050-195:1998, 195-02-06]

NOTE 1 Identification: N

NOTE 2 Definition of „neutral point“ see IEC 60050-826:2004, 826-14-05. The common point of a star-connected polyphase system is also named „star point“.

3.1.15**PEN conductor**

conductor combining the functions of both a protective earthing conductor and a neutral conductor

[IEC 60050-826:2004, 826-13-25; IEC 60050-195:1998, 195-02-12]

3.1.16**power supply**

- **primary supply:** public mains or, under emergency conditions, locally generated AC supply
- **secondary supply:** supply to the telecommunication equipment, racks or system block, derived from the primary supply
- **tertiary supplies:** supplies to the telecommunication equipment, derived from the secondary supply

[EN 300253:2002, 3.1.2]

3.1.17**protective conductor** (identification: PE)

conductor provided for purposes of safety, for example protection against electric shock

[IEC 60050-826:2004, 826-13-22; IEC 60050-195:1998, 195-02-09]

3.1.18**protective equipotential bonding system****PEBS** (abbreviation)

equipotential bonding system providing protective equipotential bonding

[IEC 60050-195:1998, 195-02-23]

3.1.19**signalling earth conductor****SE** (abbreviation)

conductor referring signalling circuits to earth potential. The signalling functions of such circuits may include signalling with earth return between different locations. A protective conductor (PE) may serve

simultaneously as an SE if the characteristics of the signalling functions harmonize with the imposed safety requirements. The CBN (of which the PE is part) can provide the SE function

3.1.20 system

regularly interacting or interdependent group of items forming a unified whole

[EN 300253:2002, 3.1.2]

3.1.21 system block

functional group of equipment depending in its operation and performance on its connection to the same system reference potential plane, inherent to a MESH-BN

[EN 300253:2002, 3.1.2]

3.1.22 system reference potential plane

SRPP (abbreviation)

conductive solid plane, as an ideal goal in potential equalizing, is approached in practice by horizontal or vertical meshes

NOTE 1 The mesh width thereof is adapted to the frequency range to be considered. Horizontal and vertical meshes may be interconnected to form a grid structure approximating to a Faraday cage.



NOTE 2 The SRPP facilitates signalling with reference to a common potential.

[EN 300253:2002, 3.1.2]

3.2 Abbreviations

AC	alternating current
BN	bonding network
BRC	bonding ring conductor
CBN	common bonding network
DC	direct current
EMC	electromagnetic compatibility
FE	functional earthing conductor
L	line conductor
L+	positive DC conductor
L-	negative DC conductor
LPS	lightning protection system
MDF	main distribution frame
MESH-BN	meshed bonding network
MET	main earthing terminal or busbar
MOD	modified
N	neutral conductor
NT	network termination
PE	protective conductor
PEN conductor	combined protective conductor and neutral conductor
SE	signal earthing conductor
SPD	surge protective device
SRPP	system reference potential plane
TE	terminal equipment

3.3 Symbols

	neutral conductor (N)
	protective conductor (PE)
	PEN conductor

4 General requirements

4.1 Safety from electrical hazards

Equipment attached to IT cabling shall be in accordance with EN 60950-1 or EN 41003, as appropriate. The installation of protective conductors (PE) and equipotential bonding conductors shall be performed according to HD 384.4.41, HD 384.5.54 and EN 61140 (requirements for installations in buildings). For the separation between power cabling and IT cabling, EN 50174-2 shall apply (see 5.5).

The conductors involved shall provide sufficiently high current conducting capability and low impedance according to the relevant safety standards in order to avoid electric shock, risk of fire, or damage to the equipment under normal or faulty operating conditions within an equipment or the electricity distribution system, or due to the impact of induced voltage and current, e. g. by lightning.

4.2 Signal reference

In order to maintain a good signal reference, emphasis should be placed on proper equipotential bonding of both the information technology and the electricity distribution systems. Signalling via earth return should be avoided, but if used the impedance of the earthing network shall be kept as low as possible.

Where a complex installation (see Figure 3) is required, a reliable signal reference shall be provided by a system reference potential plane (SRPP) dedicated at least to a functional unit or a System Block. In order to avoid undue functional distortion or risk of component failure, the SRPP shall provide sufficiently low impedance up to the highest frequency considered in the design of the equipment by using a metal plane or a meshed configuration having adequate mesh dimensions, e. g. a bonding mat. The frequency band to be covered shall include the spectral components of transients caused by switching, short circuits and atmospheric discharges.

NOTE Signal reference to the SRPP does not always imply signal return via the SRPP.

4.3 Electromagnetic compatibility (EMC)

EMC performance of information technology installations is eased if the primary supply installation of the building is a TN-S system according to HD 384.3 S2:1995, 312.2.1, and the secondary supply installation is a DC-I system.

For a complex information technology installation (see Figure 3), measures to achieve a satisfactory EMC system-performance shall be assisted by a SRPP. This SRPP shall provide sufficiently low impedance for efficient connection of filters, cabinets and cable screens. The requirement to avoid emission of, or susceptibility to electromagnetic energy under normal operating conditions may require properties of the SRPP beyond those stated in 4.2. The EMC requirements addressed include the discharge of electrostatic energy.

NOTE Requirements for the protection against overvoltages and (or) atmospheric discharge are outside the scope of this EN.

5 Requirements on bonding networks

5.1 Bonding configurations

Bonding configurations can be addressed at a building level (i. e. CBN), at an installation level (i. e. merging of CBN and meshed bonding network – MESH-BN) and at an equipment level (i. e. MESH-BN).

The bonding configuration at an equipment level adopted in this standard is a MESH-BN.

NOTE For bonding configurations of telecommunication equipment at a building and installation level, in a subscriber's building, see also Recommendation ITU-T K.31.

5.2 Common bonding network (CBN) within a building

In each building there are metallic components which shall be used to construct a basic CBN (e. g. main earthing terminal or bar, protective conductors (PE), metallic plumbing, structural steel, reinforcement rods). Such a basic CBN can be improved by additional conductive components (e. g. equipotential bonding conductors, bonding ring conductors, cable racks) to the extent that the CBN has a sufficiently low impedance and high current conducting capability to meet the general requirements of clause 4. Equipotential bonding conductors shall be used. For examples of simple CBN configurations for an information technology installation inside a building see Figures 1 and 2.

Each building shall be provided with a designated main earthing terminal or bar (MET), located as close as possible to the AC distribution and information technology cable entrance facilities. Depending on the degree of complexity and the size of the information technology installation, the MET of the building shall be extended by a bonding ring conductor (BRC) along the inside perimeter of the equipment room or the inside perimeter of the building (see Figure 3) when required. This BRC shall at least comprise a system block by its outer perimeter.

In order to minimize surge currents and voltages in the building, the screens of all cables entering the building shall be bonded to the MET via a low-impedance path, i. e. by the shortest possible connection (see Figures 1, 2 and 3).

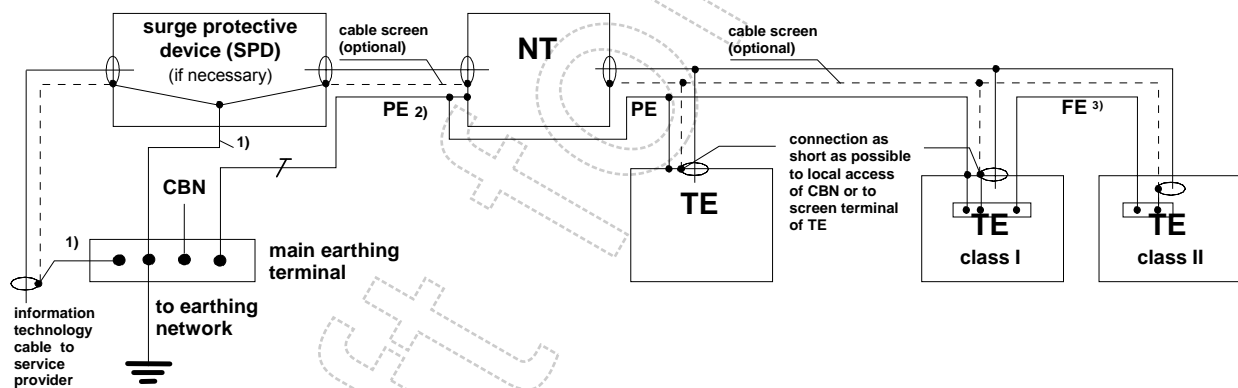

- 1) Low impedance path; keep as short as possible (see 5.2).
- 2) Protective conductor (PE) to be routed in close proximity to signal cables to minimize loop area (see 5.5).
- 3) Functional earthing conductor (FE), e. g. signal earthing conductor, optional for equipment using earth return signalling.

NOTE If NT and TE have non-conducting cases, then the PE is not connected to the case.

Figure 1 - Example of a simple common bonding network (CBN) configuration (installation of network termination e.g. for ISDN basic access)

An extension of the information technology installation inside a building, e. g. information technology systems situated on different floors and interconnected by metallic links, may require such a minimum CBN version to be augmented into a three dimensional grid structure, approximating a Faraday cage (EN 300253:2002, Figure 1). The impact of interfering energy in an exposed location or the need for information security may enforce the provision of shielded rooms as a maximum requirement to the CBN. For an example of an improved CBN/MESH-BN installation inside a building see Figure 3.

The earthing conductor and the equipotential bonding conductors should have insulation colored in accordance to international and national regulations.

5.3 Bonding network (BN) within an information technology system

Within an information technology system, especially a system block, the BN shall be of the mesh type. The SRPP shall provide sufficiently low impedance and high current conducting capability to meet the general requirements in clause 4.

The MESH-BN shall interconnect shelves, cabinets, rack rows, cable racks, ducts, conduits, distribution frames, cable screens and where appropriate a bonding mat to provide the required low impedance of the BN.

All metallic parts of the MESH-BN shall form an electrically continuous whole. This does not necessarily require bonding by additional bonding straps, but that improvements should be taken into account when determining the finishing and fastening methods to be used.

For an example of the implementation principles of the MESH-BN concept on an equipment see EN 300253:2002, Figure 2.

5.4 Merging of common bonding network (CBN) and meshed bonding network (MESH-BN)

5.4.1 General

All bonding networks (BN) of information technology systems shall be connected to the CBN.

Multiple interconnection between the BN and the CBN including the main earthing terminal create a meshed bonding network (MESH-BN); see Figures 1, 2 and 3.

5.4.2 Connection to other parts of equipotential bonding and earthing networks

The merged equipotential bonding and earthing networks in buildings shall include the interconnections to the following installations, if present:

- a) lightning protection systems according to series IEC 61024 and series IEC 61312;
- b) equipotential bonding measures of antenna installations (including satellite receiving equipment under private property) and cable networks according to series EN 50083;
- c) equipotential bonding measures of communication and data networks according to series EN 50174;
- d) equipotential bonding in hazardous areas, e. g. according to EN 60079-14.

5.5 Bonding and routing aspects of cabling within and between bonding networks

All information technology cabling entering the equipment room should be located close together.

Electricity distribution cables and signal cables within and between MESH-BNs shall be run tightly along the parts of the enlarged CBN.

There shall be a separation distance in accordance with EN 50174-2 between cable tracks of AC distribution cables and signal cables. This separation distance may be reduced if adequate screening is provided.

Cable screens shall be connected at both ends to the screen of the connecting hardware. Circumferential (i. e. 360 °) connections are most effective. Cable screens shall be bonded at least at one end to the SRPP.

NOTE 1 So far, when extending cable connections from existing to new equipment, it is being common use to avoid bonding the existing side by cable screens originating from the new equipment side. However, it is a consequential demand of this standard to

provide a lower impedance path by improved bonding between the equipment locations. This can be achieved by connecting the cable screens both ends at least.

NOTE 2 Although cable screens usually are dimensioned too weak to be used for equipotential bonding or protective earthing purposes and have significant values of resistance, they improve the quality of the MESH-BN due to their multiple implementation.

For more information about information technology cabling installation see EN 50174 series.

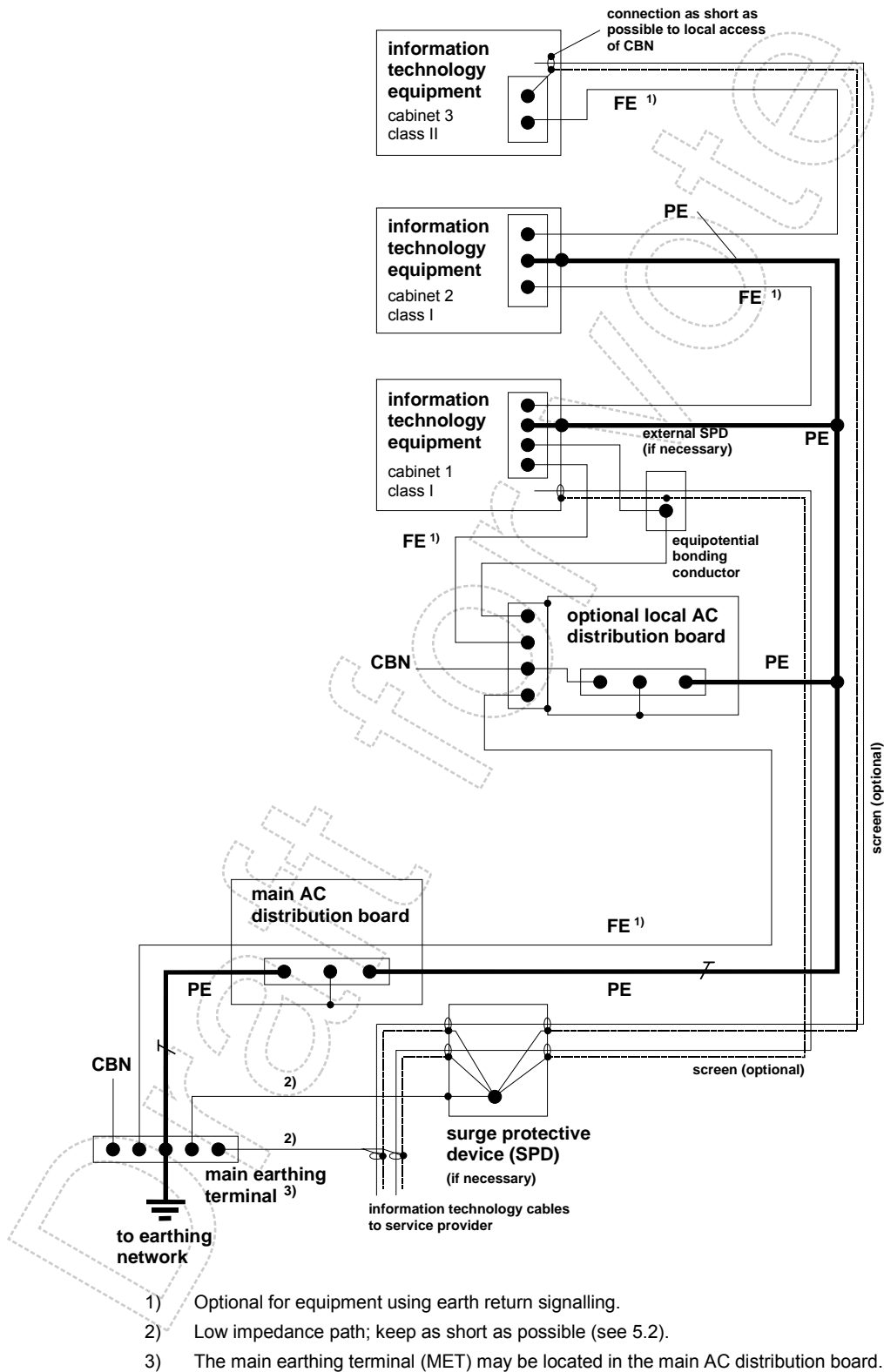

Figure 2 - Example of a common bonding network (CBN) configuration for an information technology installation inside a building

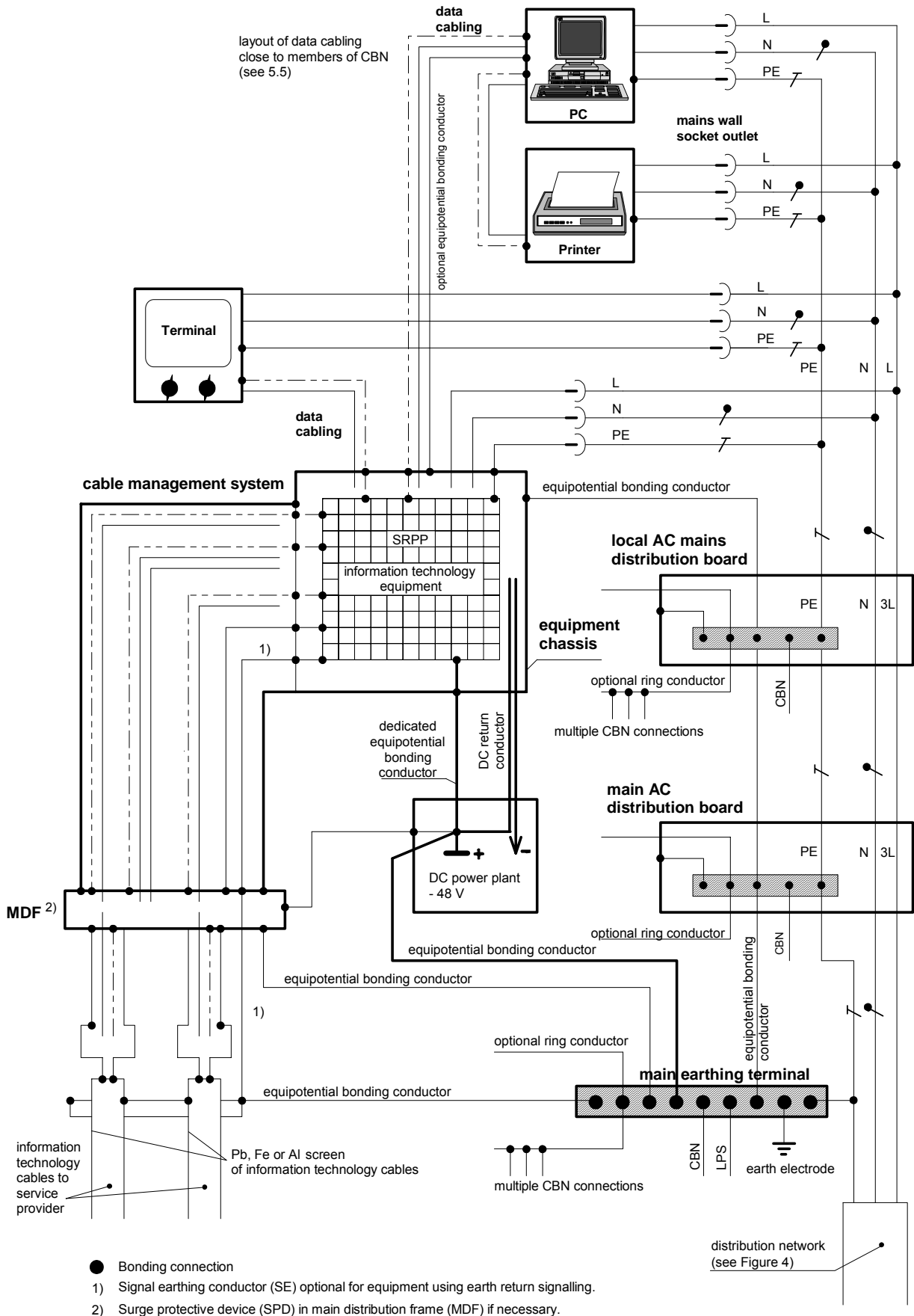

Figure 3 - Example of an improved bonding network (CBN/MESH-BN) installation inside a building

5.6 Indication of equipotential bonding conductors

All protective earthing and equipotential bonding conductors shall comply with the safety requirements according to HD 384.5.54 and shall be identified by the bi-colour combination green-and-yellow according to EN 60446.

The bi-colour combination green-and-yellow shall also be used for the identification of any conductor for equipotential bonding, which complies with the safety requirements according to HD 384.5.54 such as a protective bonding conductor (see 3.1.11) or any other conductor for a protective equipotential bonding system.

6 Requirements for electricity distribution system

6.1 DC distribution system of secondary supply

The DC distribution system, if present, shall use L+ and L– conductors routed close together and forming a DC-I-System. Therefore each DC return conductor serving an information technology system shall only be connected to the L+ output of the power plant. The L+ output shall be bonded to the CBN at least at the main earthing terminal or busbar (MET) and at the service panel of the DC power plant and to the MESH-BN to at least one point of the SRPP. The target is to avoid load currents on conductors of the equipotential bonding system during normal operation.

The maximum DC voltage drop along each dedicated DC distribution return conductor shall be dimensioned to be less than 1 V. The calculation shall take into account the maximum load current on the associated supply conductor at maximum or minimum source voltage respectively under normal operating conditions. In practice this voltage drop will be substantially reduced in a DC-C-System by virtue of additional DC return paths provided by the CBN. In a DC-I-System the voltage drop of DC return paths can not cause any corrosion of a building by stray currents. For EMC reasons, however, it is recommended not to use the CBN or MESH-BN as a return conductor.

NOTE 1 One purpose of this requirement is to avoid electrochemical corrosion by stray currents. In EN 50162:2004, Table 1, it is clearly explained that corrosion of steel in buried concrete structures arises when voltage drops become ≥ 200 mV.

NOTE 2 To achieve a minimum voltage drop in spite of high currents in L+ and L– conductors, these should have sufficient cross-sections, being important parts of the merged CBN/MESH-BN in DC-C-Systems. In DC-I-Systems the 3rd earthing conductor achieves low impedance of the CBN/MESH-BN. In addition, since the parallel impedance of the equipment connected to the conductors is low, the non-earthed L– conductor is further reducing the CBN/MESH-BN impedance.

NOTE 3 For the special arrangements of DC distribution of secondary supply see EN 300253 and EG 201147. EG 201147 provides guidance on all the interworking problems between DC-C/DC-C-, DC-C/DC-I-, and DC-I/DC-I-Systems. As a result, there are no engineering precautions to be applied when using DC-I-Systems.

The DC return path in DC-C-Systems as well as the earthing path and the DC return path in DC-I-Systems shall be capable of carrying over-currents in its entire length in the case of a fault between a negative DC conductor of the secondary supply and the MESH-BN.

The DC return terminal of a power plant powering the information technology system(s) shall be earthed at its DC service panel by a connection to the MET (see Figure 3).

For information about necessary agreements if, under exceptional conditions, DC return conductors of a single equipment group cannot be integrated into the merged CBN/MESH-BN see Annex C.

6.2 DC distribution system of tertiary supply

The reference potential terminal of tertiary power supplies shall be connected to the MESH-BN at the source only.

6.3 AC distribution system and bonding of the protective conductor

For a detailed description of the AC distribution systems see HD 384.3 S2.

The AC distribution system inside a building shall conform to the requirements of the TN-S system. This requires that there shall be no PEN conductor within the building.

Depending on the type of outdoor electricity distribution system serving a building, one of the following requirements shall apply (see Table 2 and Figure 4 to Figure 8):

a) service by a TN-S system of the outdoor electricity distribution system:

solely the protective conductor (PE) shall be connected to the main earthing terminal or bar (MET) (see Figure 4, and Figure 9, mode 1);

b) service by a TN-C system of the outdoor electricity distribution system:

- 1) the PEN conductor shall be connected to the main earthing terminal or bar (MET) only;
- 2) from the MET to and within the consumer locations inside the building the neutral conductor (N) shall be treated as a live part⁴⁾;
- 3) a dedicated protective conductor (PE) shall be provided (see Figure 5 and Figure 9, mode 2).

c) service by a TT or IT system of the outdoor electricity distribution system:

- 1) the protective conductor (PE) shall be derived via the main earthing terminal or bar (MET) from the earthing network (see Figure 7 or Figure 8, and Figure 9, mode 3);
- 2) the dimensioning of the protective conductor (PE) shall follow the rules of the TN-S system.

NOTE Public electricity distribution systems implemented as an IT system are known to be special national conditions. Because of the fact that the IT system sometimes is leading up to a TT system, these two system types are treated together in this standard. For information regarding unacceptable interference by an IT system see Annex B.

In each room containing information technology equipment or terminals which are connected to information technology equipment the bonding bar of each local AC distribution cabinet which serves the information technology equipment shall be bonded directly to the CBN (see Figure 3). If an optional bonding ring conductor (BRC) is installed, it shall be bonded directly to the CBN, at least in the four corners of the equipment room.

6.4 AC distribution system from tertiary power supply

The neutral point of a tertiary AC power supply shall be derived by bonding the terminal of the star point, or of an outer conductor (L) respectively, to the MESH-BN at the source only. The distribution to the assigned loads shall follow the rules of the TN-S system.

When using different sources for establishing power supply of information technology equipment (e. g. to provide remote power feeding for long range cable lines or the uninterruptible power supply of a sub-arrangement), the appropriate safety precautions shall be implemented without degrading the effectiveness of the general requirements in clause 4.

4) Definition of "live part" see IEC 60050-826:2004, 826-03-08.

Table 2 - Survey of electricity distribution system configurations with respect to EMC

No.	External distribution	Indoor installation		Remarks
1	TN-S ¹⁾	TN-S ¹⁾		Best electricity distribution system with respect to EMC.
2	TN-C ²⁾	TN-S ¹⁾		Recommended.
3	TN-C ²⁾	TN-C ²⁾		Not recommended for EMC reasons, see 4.3.
3 a)	TN-C ²⁾	TN-C-S ²⁾		Not recommended for EMC reasons, see 4.3.
3 b)	TN-C ²⁾	TN-C ²⁾ at basement up to main earthing terminal	TN-S ¹⁾ between floors and at floors	Recommended.
4	TT	TT		– EMC covered for indoor installations of information technology; – EMC not covered for interconnection of buildings with information technology; by-pass equipotential bonding conductor required.
5	TT	An isolating transformer ³⁾ shall be installed to realize TN-S.		Positive for EMC.
6	IT	IT		This system is widely used isolated from earth, in some installations in France, with impedance to earth, at 230/440 V, and in Norway, with a voltage limiter, neutral not distributed, at 230 V line-to-line. What concerns EMC see remarks to line 4 (TT system).
7	IT	An isolating transformer ³⁾ shall be installed to realize TN-S.		Positive for EMC.

1) TN-S systems for distribution purposes are used to be applied at premises between buildings or facilities where high EMC quality is required with respect to operational necessities. Examples are groups of buildings with cable networks for interactive services (see EN 50083 series), hospitals, broadcasting stations and transmitters as well as telecommunication centres.

2) TN-C systems, in some countries, are used for public distribution systems and similar networks.

3) For isolating transformers (definition see EN 61558-1) a type with basic insulation between the separately arranged primary and secondary windings is sufficient. For detailed information see EN 61558-2-1, EN 61558-2-4, EN 61558-2-5 and EN 61558-2-6.

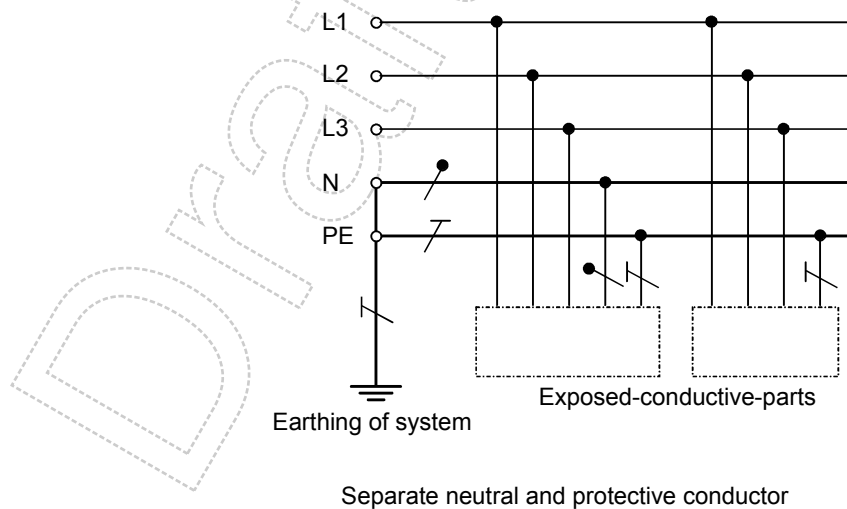

NOTE The neutral conductor (N) is only earthed once, also in multiple fed systems.

Figure 4 - TN-S system (taken from HD 384.3 S2:1995)

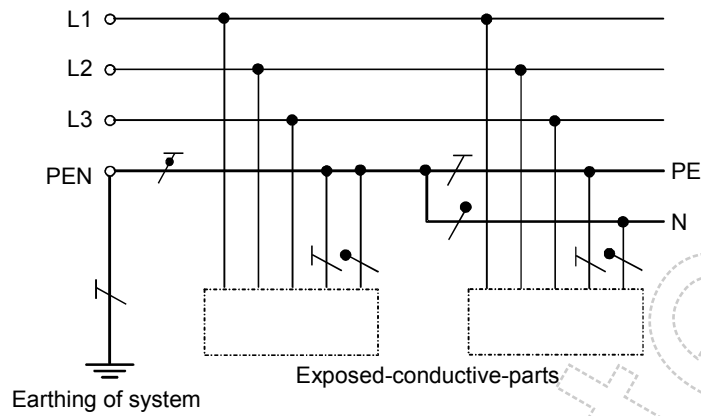

Neutral and protective functions combined in a single conductor in part of the system (PEN)

NOTE The point where the incoming PEN conductor is split up into a separate protective conductor (PE) and a neutral conductor (N) should be as close as possible to the origin of the electrical installation or (and) at the distribution panels of the building.

Figure 5 - TN-C-S system (taken from HD 384.3 S2:1995)

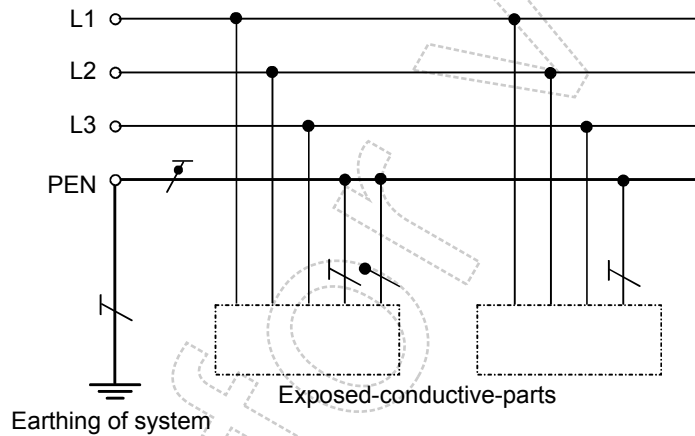

Neutral and protective functions combined in a single conductor throughout the system

Figure 6 - TN-C system (taken from HD 384.3 S2:1995)

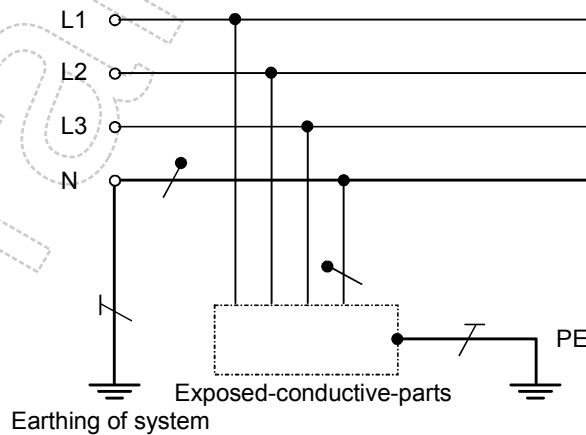

Earthed neutral and independent earthing of equipment

Figure 7 - TT system (taken from HD 384.3 S2:1995)

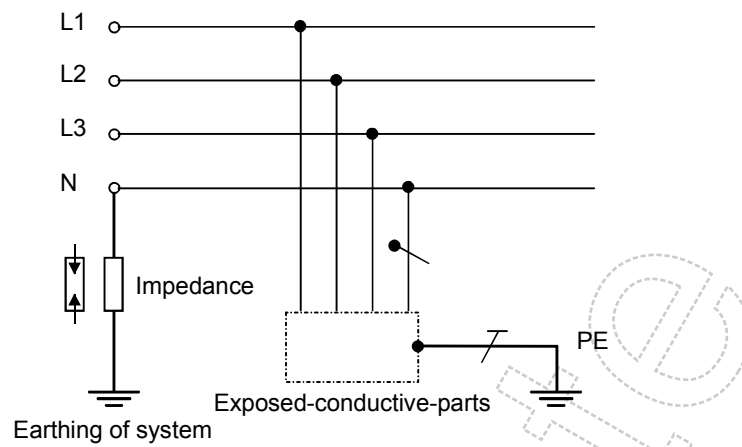

The neutral may be connected to earth through an impedance or a voltage limiter, or isolated from earth

Figure 8 - IT system (according to HD 384.3 S2:1995 and EN 60990:1999)

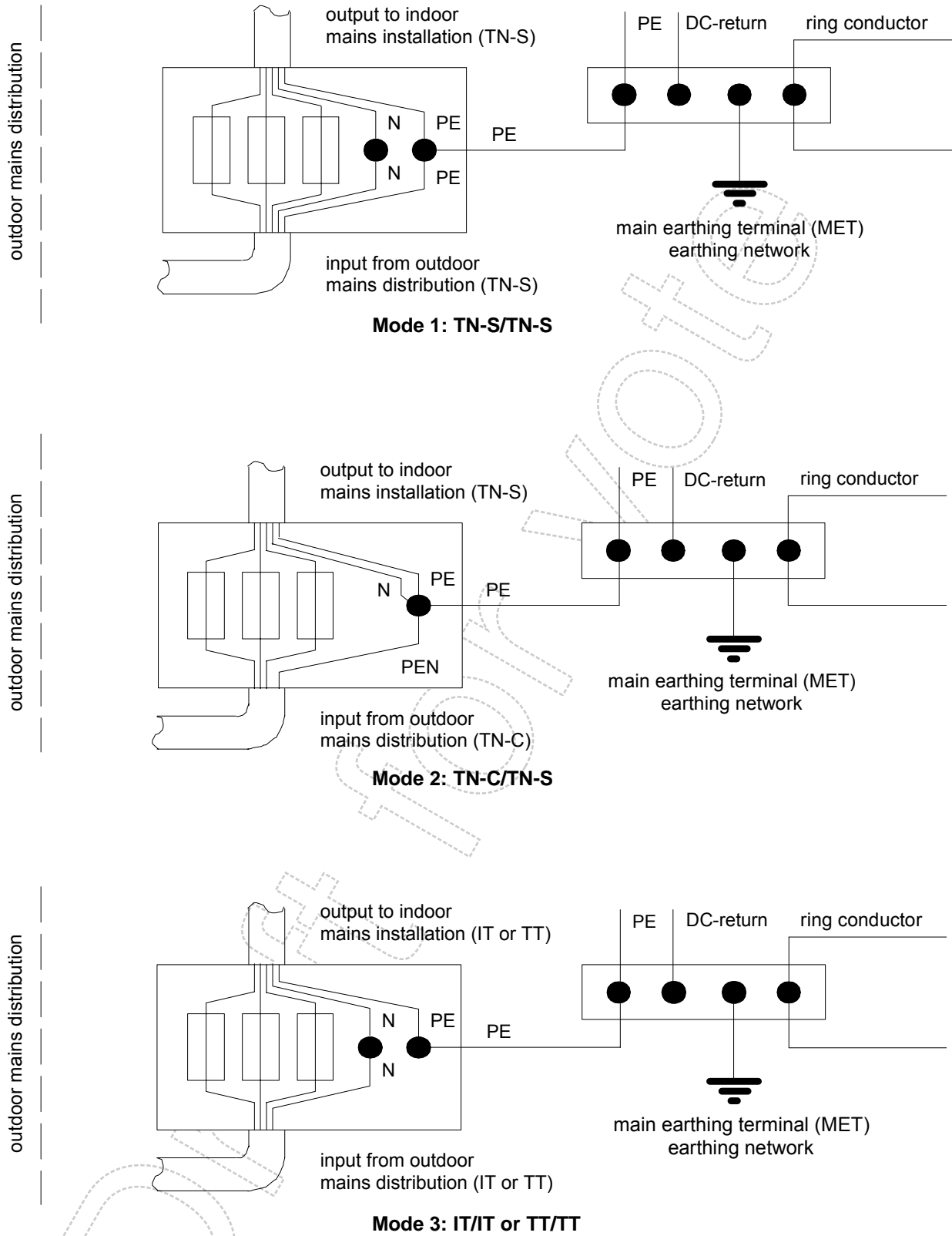

Figure 9 - Arrangements for the transition from the outdoor electricity distribution system to the indoor electricity distribution system

Annex A (normative)

Special national conditions

Special national condition: National characteristic or practice that cannot be changed even over a long period, e.g. climatic conditions, electrical earthing conditions.

NOTE If it affects harmonization, it forms part of the European Standard.

For the countries in which the relevant special national conditions apply these provisions are normative, for other countries they are informative.

Clause	Special national condition
--------	----------------------------

5.5	In Austria the Function and Protective Earth system (FPE system, also called island system) is still used in many information technology applications. The faultless operation of this system does not permit to bond cable screens directly at each end. The FPE system is directly connected to earth only by the FPE conductor and has to be insulated from other connections to earth.
-----	---

Annex B (informative)

Rationale about common bonding network (CBN) co-ordination

In order to achieve sufficient EMC performance, especially two aspects of the building design are in need of careful consideration and co-ordination:

- the complete extent of the building and all its ordinary metallic installations to be planned;
- the complete amount of information technology equipment to be installed in the building.

For new buildings, with respect to EMC, it is advantageous to provide adequate preconditions constituting a common bonding network (CBN) by:

- a reliable foundation earth electrode system, i. e. a ring conductor immediately beneath the first concrete bed;

NOTE This electrode system qualifies prior to a ring conductor along the outer perimeter of a building.

- welded joints of building steel or concrete reinforcement rods (see prEN ISO 17660 ⁵⁾ and IEC 61024-1) and a sufficient number of access terminals to these highly conductive elements;
- an enhanced outdoor lightning protection system (LPS) co-ordinated with the building structure (see IEC 61024-1);
- service pipes and air-conditioning ducts interconnected according to the CBN strategy, including potential equalisation in excess of safety regulations;
- electricity distribution system as required for the TN-S system, i. e. without any PEN section downstream from the main earthing terminal or bar (MET) and regardless of the distribution system principle applied to the electricity distribution section upstream.

Information technology equipment which is designed in accordance to this standard can be installed and interconnected to the CBN outlined above. The resulting meshed bonding network (MESH-BN), e. g. see Figure 3, corresponds to EMC requirements with ease.

⁵⁾ Developed by CEN/TC 121, presently in Enquiry stage.

Some existing buildings do not provide a CBN sufficient to meet the operational requirements. When a decision is made to extend or replace existing information technology installations in such buildings, the objective should be to move towards a CBN by enhancements.

Besides the fact that such enhancements require consultation on-site, two subjects can be addressed in general:

- an outdoor lightning protection system (LPS) may be installed at first according to IEC 61024-1 including a ring conductor as an essential member of the earthing network. The LPS may be improved with conductive roof layers, closely spaced down conductors or application of metallic facades;
- unacceptable conductive interference from the outdoor electricity distribution section can be mitigated by a separation transformer dedicated to the building or by an equivalent measure. An indoor installation according to the rules of the IT system or TT system can be upgraded by additional protective conductors (PE) and dedicated equipotential bonding conductors, thereby reducing the mesh width. A residual current protection may also be adapted if necessary.

An existing CBN can be augmented by the information technology installation regarding dedicated ring conductors per room and floor, cable management systems and any other supporting metal work. In contrast to the traditional practice to indulge into a restricted number of conductors with enlarged cross sectional area, it is recommended to aim at a large conductive surface, e. g. by providing bonding at both side bars, at joints within the run of a ladder type cable rack.

Annex C (informative)

Rationale for the integration of DC distribution systems into the merging of common bonding network (CBN) and meshed bonding network (MESH-BN)

For the integration of the DC return conductor of DC-C-systems see 5.4 and 6.1. When existing equipment requires replacement, it is essential that equipment design and installation conforms to a single standard without ambiguity (e. g. only DC-C-systems or DC-I-systems). Agreement to this aim is stated in the Foreword of this standard.

It is recognised that in existing DC-C-installations groups of equipment may be operated with „isolated“ DC return conductors, whereby „isolated“ denotes the application of the DC-I principle (3-wire system) addressed in Recommendation ITU-T K.27 (see also EN 300253 and EG 201147).

If the design of such equipment allows for operation with isolated DC return conductors, the existing installation should be adapted to this standard (DC-I-system). There are no engineering precautions required (see EG 201147).

If the operation of such equipment requires the existing DC-C-installation to be unchanged, precautions have to be taken to facilitate the desired inter system signal exchange and compliance to other EMC requirements.

Selection of such precautions shall take into account:

- inter system signal exchange by isolated and symmetrically operated circuitry;
- routing of cables with screens via a common bonding point, located as close as possible to the main earthing terminal or bar (MET), e. g. the main distribution frame, if transmission parameters allow for an additional length of the transmission path;
- appropriate conductor arrangements in parallel to the inter system cabling route with minimized length dictated by transmission requirements, i. e. provision of screening and potential equalization simultaneously;

- upgrading of the current conducting capability of the drain path for short circuit currents, i. e. provision of dedicated conductors without the steady state DC return function.

Bibliography

- EG 201147:1998, *Equipment Engineering (EE) – Interworking between Direct Current/Isolated (DC/I) and Direct Current/Common (DC/C) electrical power systems*
- EN 50098-1, *Customer premises cabling for information technology – Part 1: ISDN basic access*
- EN 50098-2, *Customer premises cabling for information technology – Part 2: 2048 kbit/s ISDN primary access and leased line network interface*
- EN 50162, *Protection against corrosion by stray current from direct current systems*
- EN 50173 (series), *Information technology – Generic cabling systems*
- EN 50174-3, *Information technology – Cabling installation – Part 3: Installation planning and practices outside buildings*
- EN 50346, *Information technology – Cabling installation - Testing of installed cabling*
- EN 60990, *Methods of measurement of touch current and protective conductor current (IEC 60990:1999)*
- EN 61558-1:1994, *Safety of power transformers, power supply units and similar – Part 1: General safety requirements and tests (IEC 61558-1:1997, modified)*
- EN 61558-2-1, *Safety of power transformers, power supply units and similar – Part 2-1: Particular requirements for separating transformers for general use (IEC 61558-2-1:1997)*
- EN 61558-2-4, *Safety of power transformers, power supply units and similar – Part 2-4: Particular requirements for isolating transformers for general use (IEC 61558-2-4:1997)*
- EN 61558-2-5, *Safety of power transformers, power supply units and similar – Part 2-5: Particular requirements for shaver transformers and shaver supply units (IEC 61558-2-5:1997)*
- EN 61558-2-6, *Safety of power transformers, power supply units and similar – Part 2-6: Particular requirements for safety isolating transformers for general use (IEC 61558-2-6:1997)*
- ETS 300132-1:1996, *Equipment Engineering (EE) – Power supply interface at the input to telecommunications equipment – Part 1: Operated by alternating current (a.c.) derived from direct current (d.c.) sources*
- EN 300132-2:2003, *Environmental Engineering (EE) – Power supply interface at the input to telecommunications equipment – Part 2: Operated by direct current (dc)*
- prEN ISO 17660:2003, *Welding – Welding of reinforcing steel (ISO/DIS 17660:2003)*
- HD 384.1 S1:1979, *Electrical installations of buildings – Part 1: Scope (IEC 60364-1:1972 + A1:1976, modified)*
- IEC 60050-195:1998 + A1:2001, *International Electrotechnical Vocabulary – Part 195: Earthing and protection against electric shock*
- IEC 60050-826, *International Electrotechnical Vocabulary – Part 826: Electrical installations*
- IEC 60364-5-548:1996, *Electrical installations of buildings – Part 5: Selection and erection of electrical equipment – Section 548: Earthing arrangements and equipotential bonding for information technology installations*
- ITU-T K.27:1996, *Bonding configurations and earthing inside a telecommunication building*
- ITU-T K.31:1993, *Bonding configurations and earthing of telecommunication installations inside a subscriber's building*
- ITU-T Handbook, *Earthing of telecommunication installations (Geneva 1976)*