

21LW1400

Extended Low Frequency Transducer

Key Features

- 99 dB SPL 1W / 1m average sensitivity
- 100 mm (4 in) Interleaved Sandwich Voice coil (ISV)
- 1500W AES power handling
- Double Silicon Spider (DSS) for improved excursion control and linearity
- Double Demodulating Rings (DDR) for lower distortion
- Improved heat dissipation via unique basket design
- Weather protected cone and plates for outdoor usage
- Suitable for ultra low frequency systems



General Description

The 21LW1400 is a 21 inch high performance extended low frequency loudspeaker. The transducer can be used as a subwoofer component, in either a reflex, band-pass or horn-loaded configuration, in high power auditorium or arena loudspeaker systems. It provides clean and undistorted LF reproduction at very high SPL and enables the speaker to withstand high power levels without damage.

The 21LW1400 design features include an exceptional displacement suspension system which, in conjunction with a carbon fiber reinforced straight-ribbed cone and the Double Silicon Spider (DSS), produces an ultra-linear piston action, providing full control across the entire working range.

The 100mm inside outside copper voice coil, based on our Interleaved Sandwich Voice-coil (ISV) technology, reaches high levels of thermal stability and durability. ISV technology is based on a high strength fiberglass former with half the coil wound on the outside and half on the inside and bonded together using unique high temperature resin adhesives. This results in a balanced linear motor unit which can exert an exceptionally high force factor.

The low distortion and unmatched sound quality of the 21LW1400 has been significantly improved by the Double Demodulating Rings (DDR) embedded in the pole piece of the magnetic structure. These have been designed to dramatically reduce the intermodulation and harmonic distortion while improving transient response at the same time.

Excellent heat dissipation has been achieved using the special basket design which incorporates air channels between the basket and the magnetic top plate. In addition, 8 air vents incorporated into the back plate are aligned with the voice coil to force air into the lower part of the gap.

21LW1400 is ready to perform properly under inclement weather conditions. This has been achieved using of an exclusive treatment which improves pulp strength and gives water repellent properties to both sides of the cone. Moreover, a special treatment is applied to the top and back plate of the magnetic structure which is far more resistant to the corrosive effects of salts and oxidization than any other treatment in use.

0222183110 8 Ohm

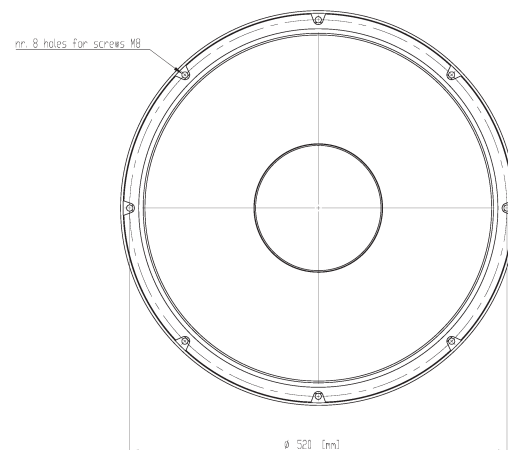
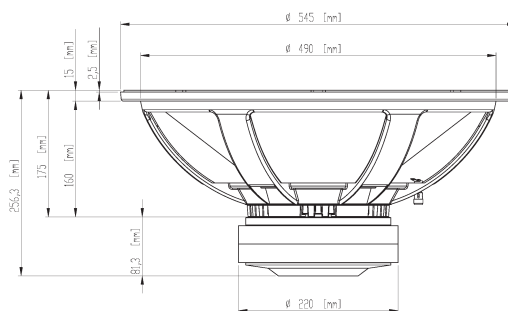

FERRITE LF-MB-MF TRANSDUCERS

21LW1400

Extended Low Frequency Transducer

GENERAL SPECIFICATIONS

NOMINAL DIAMETER	533 mm (21 in)
RATED IMPEDANCE	8 Ohm
AES POWER	1500 W
PROGRAM POWER (1)	1600 W
PEAK POWER (2)	7000 W
SENSITIVITY (3)	99 dB
FREQUENCY RANGE (4)	24 - 2000 Hz
POWER COMPRESSION @-10DB (5)	0,6 dB
POWER COMPRESSION @-3DB	1,5 dB
POWER COMPRESSION @FULL POWER	2,2 dB
MAX RECOMM. FREQUENCY	250 Hz
RECOMM. ENCLOSURE VOLUME	120 ÷ 500 lt. (4,24 ÷ 17,7 cuft)
MINIMUM IMPEDANCE	6,4 Ohm at 25°C
MAX PEAK TO PEAK EXCURSION	52 mm (2,05 in)
VOICE COIL DIAMETER	100 mm (4 in)
VOICE COIL WINDING MATERIAL	copper
SUSPENSION	Triple roll, Polycotton
CONE	Straight ribbed, Paper

THIELE SMALL PARAMETERS (6)

Fs	28 Hz
Re	5 Ohm
Sd	0,1662 sq.mt. (257,6 sq.in.)
Qms	9,32
Qes	0,242
Qts	0,235
Vas	385 lt. (13,6 cuft)
Mms	296 gr. (0,65 lb)
BL	33,5 Tm
Linear Mathematical Xmax (7)	± 9,5 mm (± 0,37 in)
Le (1kHz)	2,85 mH
Ref. Efficiency 1W@1m (half space)	98,0 dB

MOUNTING INFORMATION

Overall diameter	545 mm (21,46 in)
N. of mounting holes	8
Mounting holes diameter	10 mm (0,39 in)
Bolt circle diameter	520 mm (20,47 in)
Front mount baffle cutout ø	492 mm (19,37 in)
Rear mount baffle cutout ø	490 mm (19,29 in)
Total depth	256,3 mm (10,1 in)
Flange and gasket thickness	14 mm (0,55 in)
Net weight	19,2 kg (42,38 lb)
Shipping weight	20,6 kg (45,47 lb)
CardBoard Packaging dimensions	550 x 550 x 300 mm (21,65 x 21,65 x 11,8 in)

FREQUENCY RESPONSE CURVE OF 21LW1400 MADE ON 250 LIT. ENCLOSURE TUNED 28HZ IN FREE FIELD (4PI) ENVIRONMENT. ENCLOSURE CLOSES THE REAR OF THE DRIVER. THE THIN LINE REPRESENTS 45 DEG. OFF AXIS FREQUENCY RESPONSE

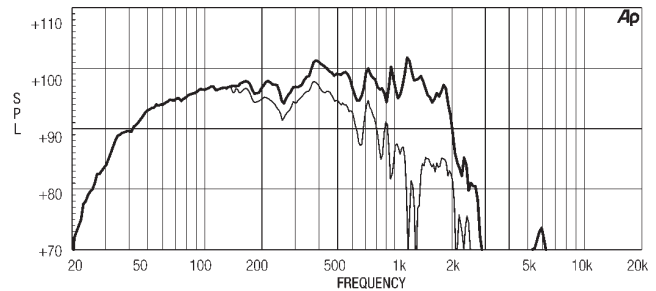

FREE AIR IMPEDANCE MAGNITUDE CURVE

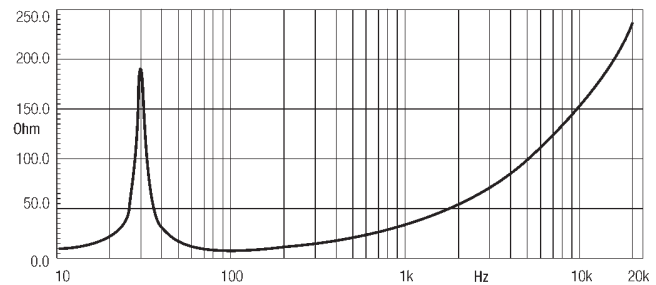

NOTES

- (1) Program power rating is measured in 250 lit enclosure tuned 28Hz using a 40 - 400Hz band limited pink noise test signal with 50% duty cycle, applied for 2 hours.
- (2) The peak power rating represents the maximum permitted instantaneous peak power level over a maximum period of 10ms which will be withstood by the loudspeaker without damage.
- (3) Sensitivity represents the averaged value of acoustic output as measured on the forward central axis of cone, at distance 1m from the baffle panel, when connected to 2,83V sine wave test signal swept between 100Hz and 500Hz with the test specimen mounted in the same enclosure as given for (1) above.
- (4) Frequency range is given as the band of frequencies delineated by the lower and upper limits where the output level drops by 10 dB below the rated sensitivity in half space environment.
- (5) Power compression represents the loss of sensitivity for the specified power, measured from 50-500 Hz, after a 5 min pink noise preconditioning test at the specified power.
- (6) Thiele - Small parameters are measured after the test specimen has been conditioned by 1500 W AES power and represent the expected long term parameters after a short period of use.
- (7) Linear Math. Xmax is calculated as $(Hvc-Hg)/2 + Hg/4$ where Hvc is the coil depth and Hg is the gap depth.

Eighteen Sound engages in research and product improvement. New materials and design refinements can be introduced into existing products without notice.