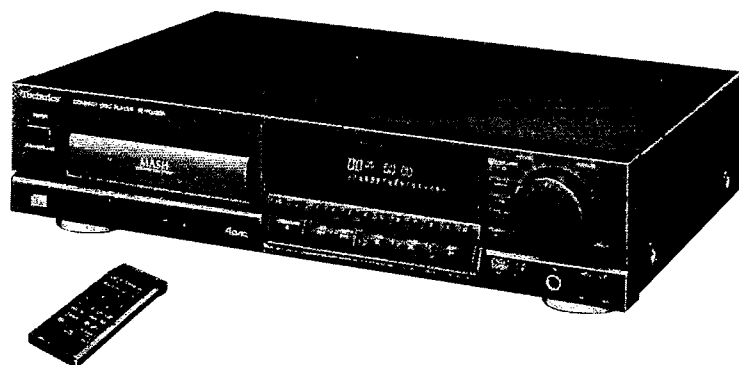

Service Manual

Compact Disc Player

SL-PG520A

COMPACT
disc
DIGITAL AUDIO
DIGITAL
MASH*
 multi-stage noise shaping

Colour

 (K) ... Black Type
 (S) ... Silver Type

Area

Suffix for Model No.	Area	Colour
(E)	Continental Europe.	(K) (S)
(EB)	Great Britain.	
(EG)	F.R. Germany & Italy.	

SPECIFICATIONS

Audio

No. of channels	2 (left and right, stereo)
Frequency response	2-20,000 Hz, ± 0.5 dB
Output voltage	2 V (at 0 dB)
Dynamic range	98 dB
S/N ratio	103 dB
Harmonic distortion	0.002% (1 kHz, 0 dB)
Total harmonic distortion	0.003% (1 kHz, 0 dB)
Wow and flutter	Below measurable limit
DA converter	MASH (4 DAC)
Output impedance	Approx. 600 Ω
Load impedance	More than 10 k Ω
Headphone output level	15 mW max. 32 Ω (adjustable)

Pickup

Wavelength	780 nm
------------	--------

General

Power supply	AC 50/60 Hz, 230 V-240 V
Power consumption	10 W
Dimensions (W×H×D)	430×103×293 mm
Weight	3.8 kg

Note:

Specifications are subject to change without notice.
 Weight and dimensions are approximate.

- Technics (or Panasonic) developed the world's first MASH type DAC and ADC. MASH technology was invented by NTT (LSI Labs).
- ※ MASH is a trademark of NTT.

CONTENTS

	Page
PLACEMENT.....	2
CLEANING OF LENS.....	2
ACCESSORIES.....	2
PRECAUTION OF LASER DIODE.....	3
LOCATION OF CONTROLS.....	4
CONNECTIONS.....	5
DISASSEMBLY INSTRUCTIONS.....	6~9
CHECKING OF THE SERVO P.C.B.....	9
MEASUREMENTS AND ADJUSTMENTS.....	10, 11
TERMINAL FUNCTION OF IC'S.....	12~15
BLOCK DIAGRAM.....	16, 17
INTERNAL CONNECTION OF FL.....	18

	Page
SCHEMATIC DIAGRAM.....	19~24
TERMINAL GUIDE OF IC'S, TRANSISTORS AND DIODES.....	24
PRINTED CIRCUIT BOARDS.....	25~28
WIRING CONNECTION DIAGRAM.....	29
REPLACEMENT PARTS LIST.....	30~32
EXPLODED VIEWS.....	33~35
RESISTORS & CAPACITORS.....	36, 37
PACKING.....	37
TROUBLESHOOTING GUIDE.....	38~40

*** TECHNICAL INFORMATION**

* This technical information is located on pp 49~56 of the SL-PJ46A Service Manual (Order No. AD8902036C2). Therefore, refer to that Service Manual.

Technics

■ PLACEMENT

Before placement

Two transport security devices are secured to prevent the optical pickup from damage during transport. Be sure to release them before use.

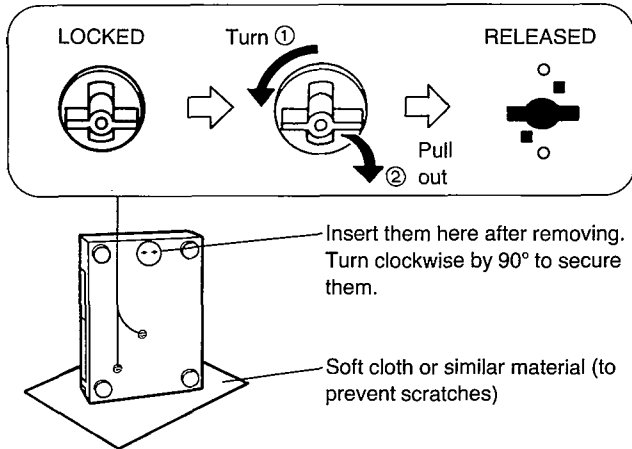

Note:

When transporting the unit, be sure to remove the compact disc from inside the unit. And replace the transport security devices again following the reverse order not to damage the optical pickup.

■ CLEANING OF LENS

If the lens is stained causing sound skip or operation failure, open the top cover by pressing the open button, and clean the lens.

• **To remove dust or dirt**

Blow the lens with the blower provided in the cleaning kit to remove dust or dirt.

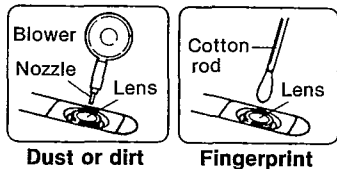

• **To remove fingerprint**

If the blower is not enough, moisten the cotton rod with the lens cleaner solution and wipe the lens with it from center of the lens to outside.

Notes of placement

- **This unit is a precision instrument. Be sure to place it on a flat surface.**
 - **Avoid places such as the following:**
 - Near any equipment or device that generates strong magnetism.
 - On any heat-generating equipment or device, or in any place where the temperature is high (35°C or higher).
 - Extremely cold places (5°C or below).
 - Near a tuner or TV (It may cause noise in the broadcast, or disturbance of the TV picture.)
 - **When carrying or storing the unit, handle it with care so that it is not subjected to any strong bumps.**
- Always remove the compact disc before storing the unit for any period of time.
- **To avoid problems due to vibration.**
 - Do not place a book or similar object under this unit.
 - Do not route the connection cables (of this or other units) across the operation panel, across the top, or under the unit.

Cautions:

- Do not directly apply the cleaner solution to the lens. Do not apply too much solution to the cotton rod or otherwise the solution will flow into the player.
- Wipe the lens carefully. Do not give too much stress to the lens or otherwise it may scratch the lens or cause optical pickup trouble.
- If the solution should be too much applied, wipe the lens with a dry cotton rod.

Lens cleaning kit (Part No. : SZZP1038C)

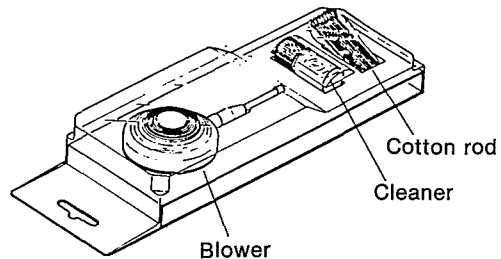

■ ACCESSORIES

- AC power supply cord... 1 pc.
[RJA0018-K (E, EG)]
[SJA193 (EB)]
- Stereo connection cable.. 1 pc.
(SJP2249-3)
- Remote control transmitter
(Black: EUR64798)
(Silver: EUR64799) 1 pc.
- Batteries 2 pcs.
Use two UM-4,
"AAA" (R03) size
(1.5V) batteries.

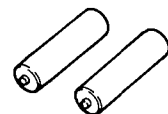
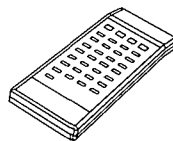
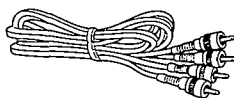
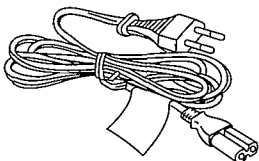

Note: Configuration of AC power supply cord differs according to area.

■ PRECAUTION OF LASER DIODE

CAUTION: This product utilizes a laser diode with the unit turned "on", invisible laser radiation is emitted from the pick up lens.

Wave length: 780nm

Maximum output radiation power from pick up: 100 μ W/VDE

Laser radiation from the pick up lens is safety level, but be sure the followings:

1. Do not disassemble the optical pick up unit, since radiation from exposed laser diode is dangerous.
2. Do not adjust the variable resistor on the pickup unit. It was already adjusted.
3. Do not look at the focus lens using optical instruments.
4. Recommend not to look at pick up lens for a long time.

ACHTUNG: Dieses Produkt enthält eine Laserdiode. Im eingeschalteten Zustand wird unsichtbare Laserstrahlung von der Lasereinheit abgestrahlt.

Wellenlänge: 780 nm

Maximale Strahlungsleistung der Lasereinheit: 100 μ W/VDE

Die Strahlung an der Lasereinheit ist ungefährlich, wenn folgende Punkte beachtet werden:

1. Die Lasereinheit nicht zerlegen, da die Strahlung an der freigelegten Laserdiode gefährlich ist.
2. Den werkseitig justierten Einstellregler der Lasereinheit nicht verstellen.
3. Nicht mit optischen Instrumenten in die Fokussierlinse blicken.
4. Nicht über längere Zeit in die Fokussierlinse blicken.

ADVARSEL: I dette a apparat anvendes laser.

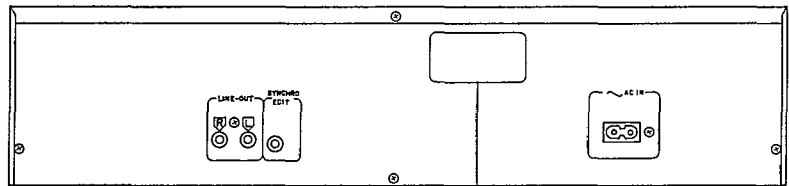

SQWD7



RQLS0060

VARO! Avattaessa ja suojalukitus ohitettaessa olet alttiina näkymättömälle lasersäteilylle. Älä katso säteeseen.

VARNING! Osynlig laserstrålning när denna del är öppen och spärren är urkopplad. Betrakta ej strålen.

RQLS0060

Obs:

Apparaten innehåller laser Komponent av höger laserklass än klass 1.

RQLS0022

ADVARSEL: USYNLIG LASERSTRÅLING VED ÅBNING, NÅR SIKKERHEDSAFBRYDERE ER UDE AF FUNKTION. UNDGÅ UDSÆTTELSE FOR STRÅLING.

VORSICHT-Unsichtbare Laserstrahlung, wenn Abdeckung geöffnet. Nicht dem Strahl aussetzen.

RQLS0022

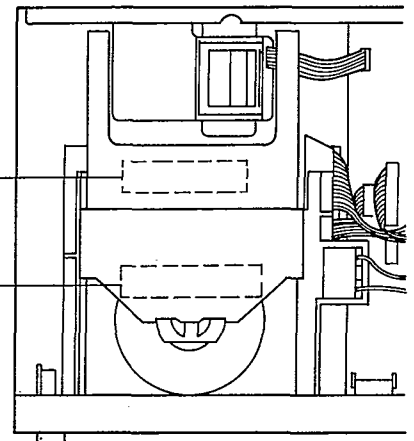

LOCATION OF CONTROLS

The functions indicated by the black numbers (with white background, ④ etc.) can also be activated using the remote control transmitter.

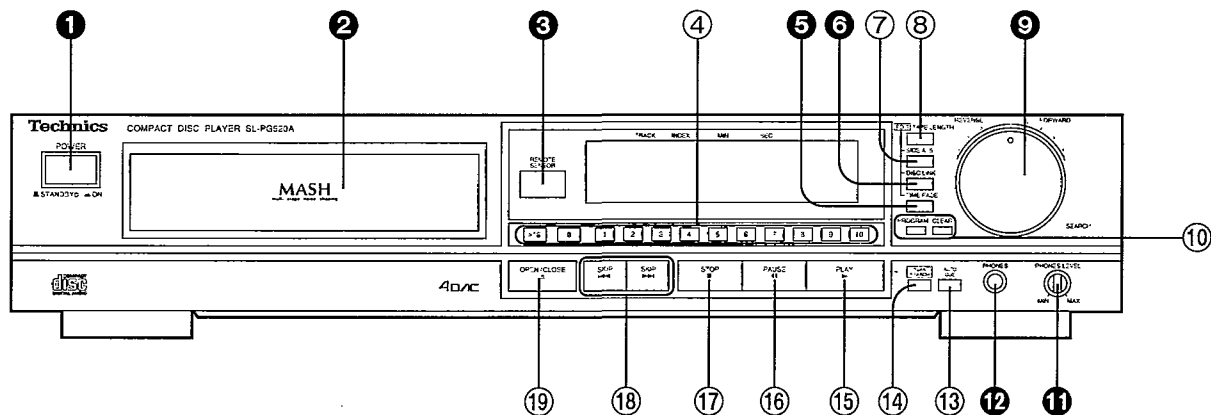

Control section

① Power "STANDBY $\text{\textcircled{O}}$ /ON" switch (POWER \blacksquare STANDBY $\text{\textcircled{O}}$ \blacksquare ON)

This switch switches ON and OFF the secondary circuit power only. The unit is in the "standby" condition when this switch is set to the STANDBY $\text{\textcircled{O}}$ position. Regardless of the switch setting, the primary circuit is always "live" as long as the power cord is connected to an electrical outlet.

② Disc tray

③ Remote control signal sensor (REMOTE SENSOR)

④ Numeric buttons (>10, 0, 1~10)

⑤ Time fade button (TIME FADE)

Pressing this button in the pause or stop mode causes the fade-out function to work at the specified time. Pressing this button in the edit mode causes the fade-out function to work at the end of the tape when the added track exceeds the remaining time of the tape.

⑥ Disc link button (DISC LINK)

This button can be used for edit recording from several discs.

⑦ Tape-side select button (SIDE A/B)

When recording compact discs to tape, this button can be used to check the number of tracks and amount of tape left over for side A or B.

⑧ Edit tape length button (TAPE LENGTH)

When compact discs are to be recorded to tape, this button can be used to calculate the number of tracks that can be recorded on each side of the tape, depending on the length of the cassette tape to be used, so that as little tape as possible is wasted.

⑨ Search dial (SEARCH)

This dial can be used to locate specific places on the disc during play at high speed, either forward or reverse.

⑩ Buttons for program function

• Program button (PROGRAM)

Pressing this button initiates the program play mode. You can then enter specific tracks using the numeric buttons.

• Clear button (CLEAR)

Each pressing this button makes one track cleared from the programmed sequence.

⑪ Headphones volume control (PHONES LEVEL)

Avoid listening to music at high volume levels for extended periods of time.

⑫ Headphones jack (PHONES)

⑬ Auto cue button (AUTO CUE)

Pressing this button enables the unit to stop at the beginning of every track and switch to the play standby mode.

⑭ Peak level search button (PEAK SEARCH)

Pressing this button enables the unit to search out the "peak signal" locations in tracks on a disc so as to adjust the suitable recording level on the cassette deck.

⑮ Play button (\blacktriangleright PLAY)

⑯ Pause button ($\text{\textcircled{II}}$ PAUSE)

⑰ Stop button (\blacksquare STOP)

This button can be used to stop disc play, as well as to cancel the various play modes.

⑱ Skip buttons ($\text{\textcircled{<<}}$ SKIP, $\text{\textcircled{>>}}$ SKIP)

These buttons can be used to skip by track in the forward or reverse direction.

⑲ Disc tray open/close button (\blacktriangle OPEN/CLOSE)

Indicators section

⑳ Disc link indicator (LINK)

㉑ Program indicator (PGM)

㉒ Track number display (TRACK)

㉓ Index/program number display (INDEX, No.)

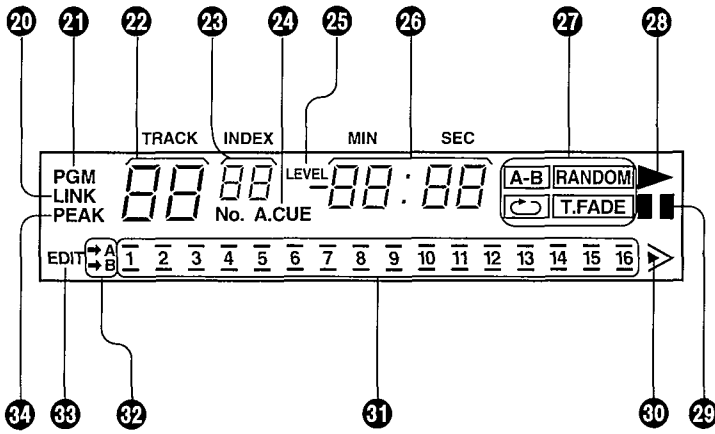

24 Auto cue indicator (A. CUE)

25 Level indicator (LEVEL)

This indicator lights when the output level is attenuated by the remote control.

26 Time display (MIN, SEC)

27 Operation indicators

The following indicators light during their respective operations.

- A-B** : Peak level search
A-B repeat play (remote control operation)
- RANDOM** : Random play (remote control operation)
- REPEAT** : Repeat play (remote control operation)
- T. FADE** : Time fade (fade-out)

28 Play indicator (▶)

29 Pause indicator (||)

30 "Over" mark (➤)

This indicator lights if the total number of tracks on the disc is 17 or more.

31 Track number indicator (1-16)

32 Tape side indicator (→ A, → B)

33 Compact disc edit indicator (EDIT)

34 Peak level search indicator (PEAK)

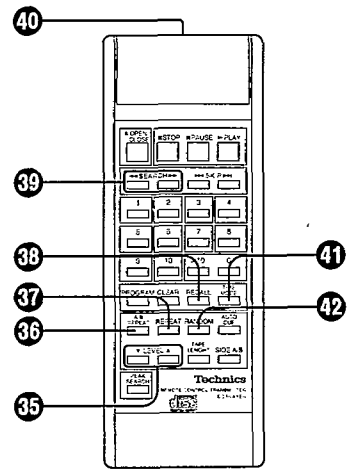

Remote control transmitter

Unnumbered buttons on the remote control transmitter function identically to their corresponding parts on the unit.

35 Level buttons (▼ LEVEL ▲)

These buttons can be used to adjust output level (from 0 dB to -12 dB).

36 A-B repeat button (A-B REPEAT)

This button can be used to play the portion of a disc between two points (A and B) chosen by you.

37 Repeat button (REPEAT)

38 Recall button (RECALL)

This button can be used to display the contents of the programmed track sequence for confirmation.

39 Search buttons (◀◀SEARCH▶▶)

These buttons can be used to move rapidly forward or backward on the disc during play. The search speed is slow when the button is pressed at first and becomes faster if the button is pressed and held continuously.

40 Remote control signal transmission window

41 Time mode select button (TIME MODE)

42 Random play button (RANDOM)

This button can be used to play the tracks on a disc in a random sequence.

CONNECTIONS

Turn all components off before making connections.

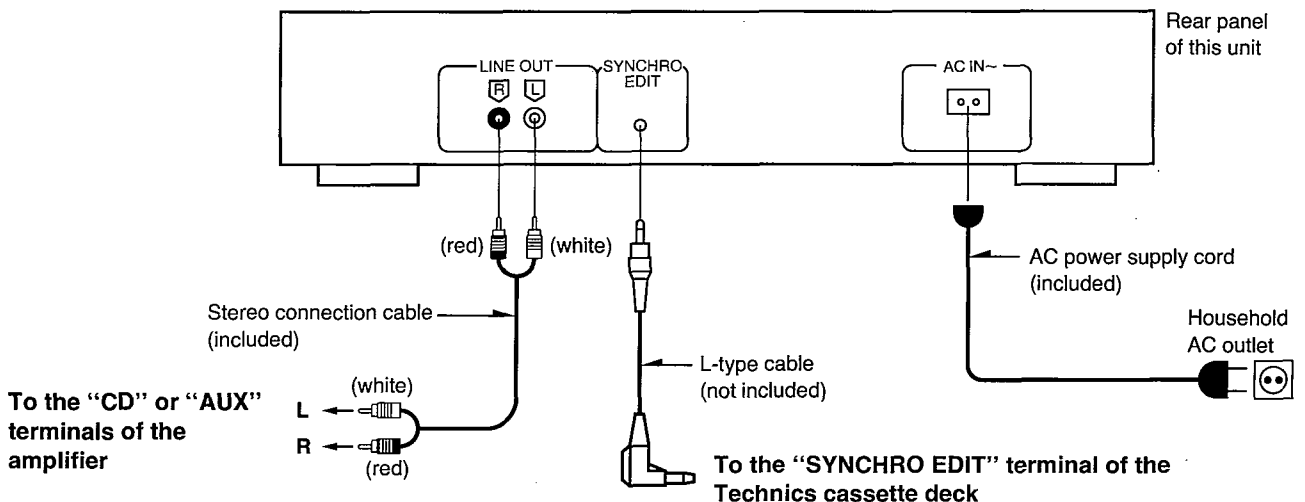

DISASSEMBLY INSTRUCTIONS

Warning: This product uses a laser diode. Refer to caution statements on page 3.

ACHTUNG:

- Die Lasereinheit nicht zerlegen.
- Die Lasereinheit darf nur gegen eine vom hersteller spezifizierte einheit ausgetauscht werden.

*This CD player is equipped with FPC boards, so handle them with care during disassembly and reassembly.

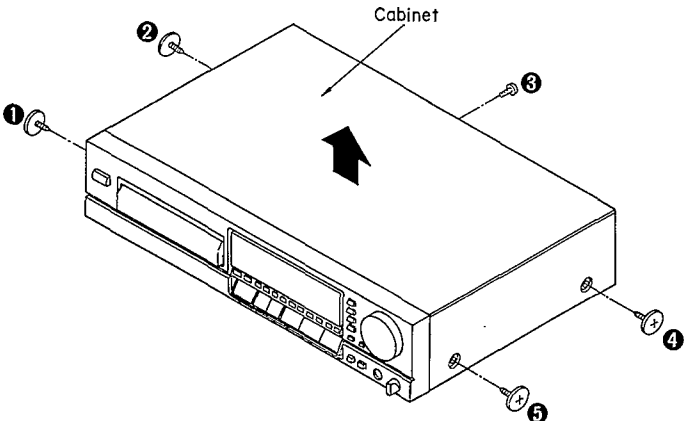
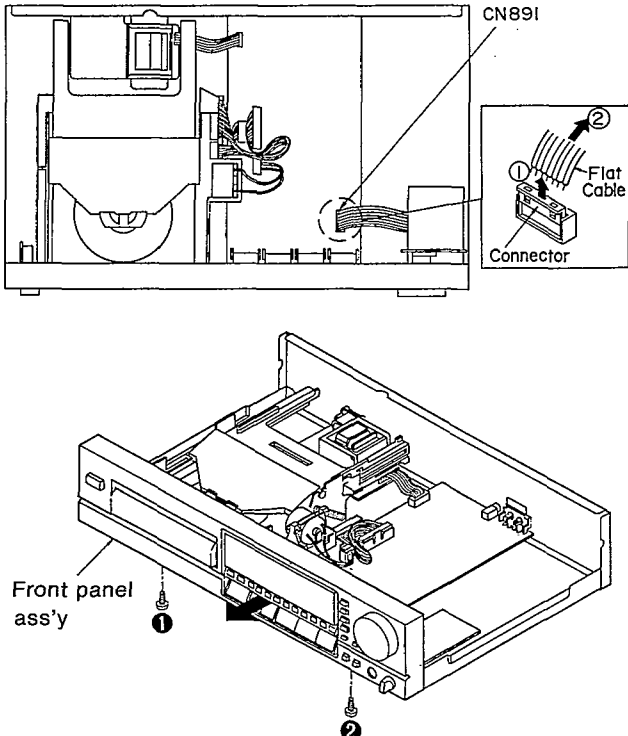
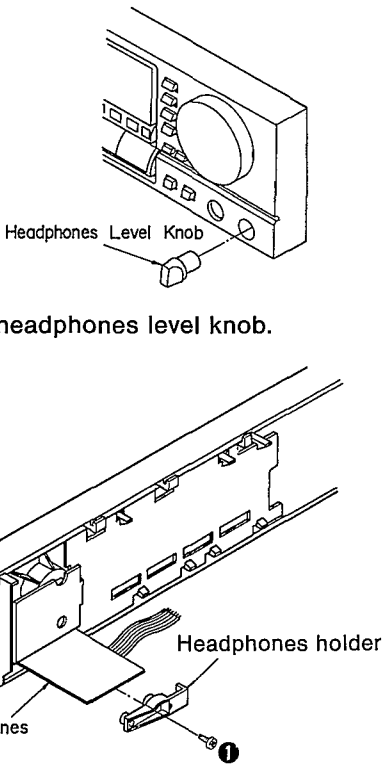
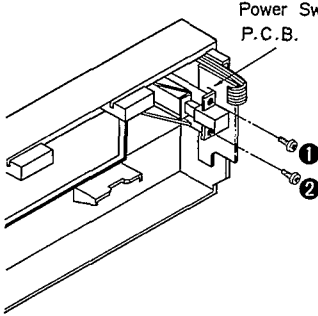
<p>Ref. No. 1</p>	<p>Removal of the cabinet</p>	<p>Ref. No. 2</p>	<p>Removal of the front panel ass'y</p>
<p>Procedure 1</p>	 <p>• Remove the 5 screws (①~⑤).</p>	<p>Procedure 1→2</p>	 <ol style="list-style-type: none"> 1. Remove the 1 flat cable (CN891). 2. Remove the 2 screws (①, ②). 3. Remove the front panel ass'y in the direction of the arrow.
<p>Ref. No. 3</p>	<p>Removal of the headphones P.C.B.</p>	<p>Ref. No. 4</p>	<p>Removal of the power switch P.C.B.</p>
<p>Procedure 1→2→3</p>	 <ol style="list-style-type: none"> 1. Pull out the headphones level knob. 2. Remove the 1 screw (①). 3. Remove the headphones holder. 	<p>Procedure 1→2→4</p>	 <p>• Remove the 2 screws (①, ②).</p>

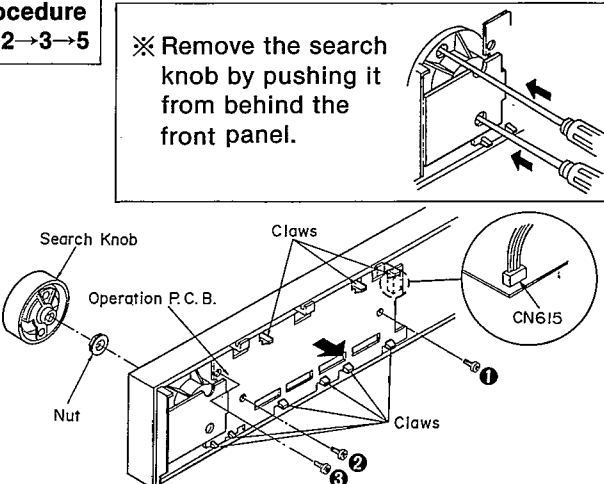
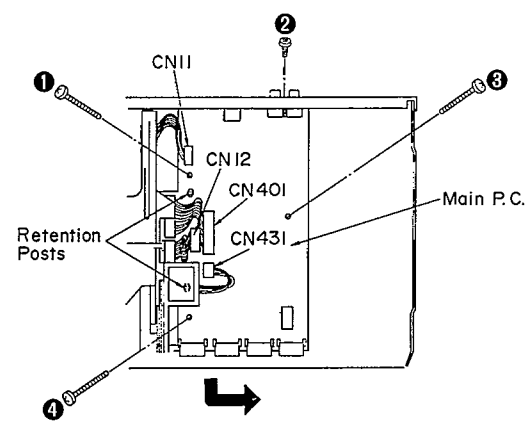
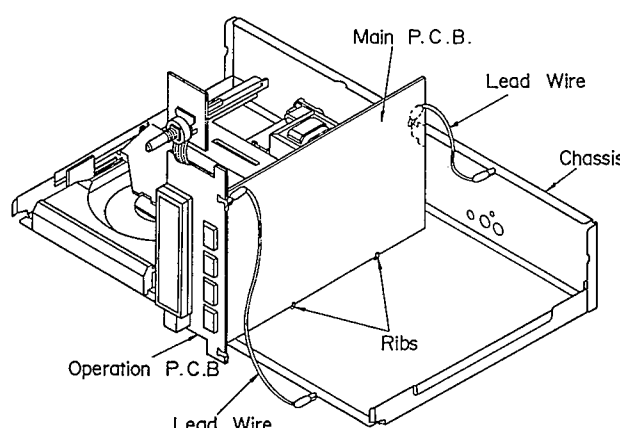
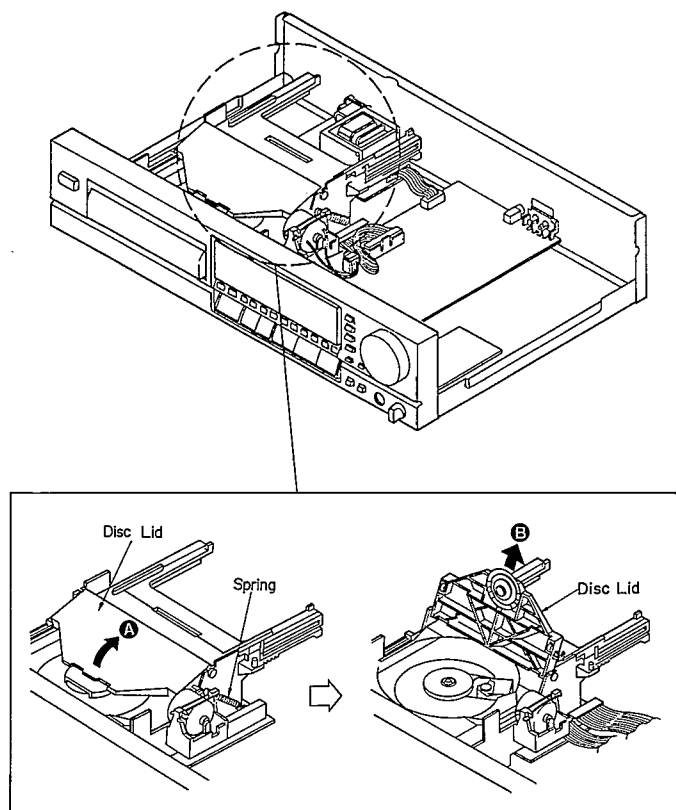
<p>Ref. No. 5</p> <p>Removal of the operation P.C.B. and search P.C.B.</p> <p>Procedure 1→2→3→5</p>	<p>※ Remove the search knob by pushing it from behind the front panel.</p>  <ol style="list-style-type: none"> 1. Remove the 3 screws (①~③). 2. Release the 9 claws. 3. Pull out the search knob. 4. Remove the 1 nut. 5. Remove the operation P.C.B. and search P.C.B. in the direction of the arrow. 6. Remove the 1 flat cable (CN615). 	<p>Ref. No. 6</p> <p>Removal of the main P.C.B.</p> <p>Procedure 1→2→3 →5→6</p>  <ol style="list-style-type: none"> 1. Remove the 4 screws (①~④). 2. Remove the 3 connectors (CN12, CN401, CN431). 3. Remove the 1 flat cable (CN11). 4. Lift the main P.C.B. off the retention posts on the chassis. 5. Remove the main P.C.B. in the direction of the arrow. <p>How to check the main P.C.B.</p> <p>When checking the soldered surface of the main P.C.B. and replacing the parts, do as shown below.</p> <ol style="list-style-type: none"> 1. Don't remove the connectors (CN12, CN401, CN431) and flat cable (CN11). 2. Connect the main P.C.B. ground terminal (LINE OUT terminal) to the chassis with a lead wire. 3. Connect the operation P.C.B. ground terminal to the chassis with a lead wire. 
<p>Ref. No. 7</p> <p>Removal of the disc lid</p> <p>Procedure 1→7</p>	<ol style="list-style-type: none"> 1. Remove the spring. 2. Move the disc lid in the direction of the arrow (A) and pull out this in the direction of the arrow (B). 	

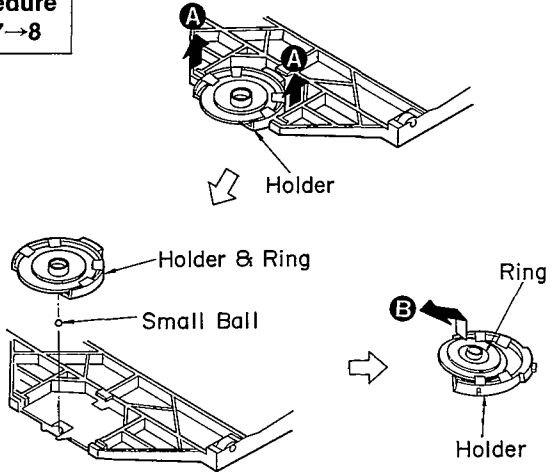
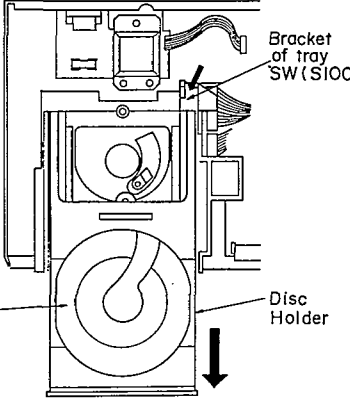
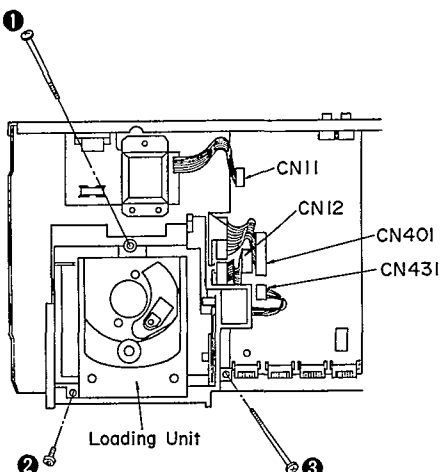
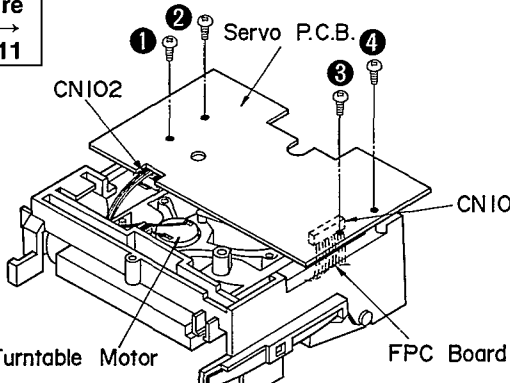
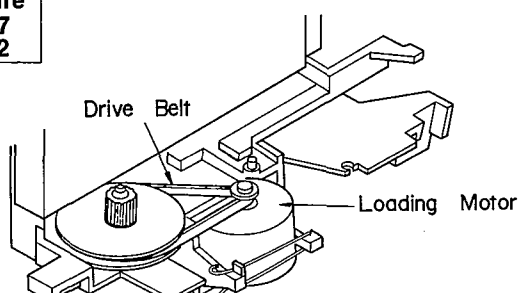
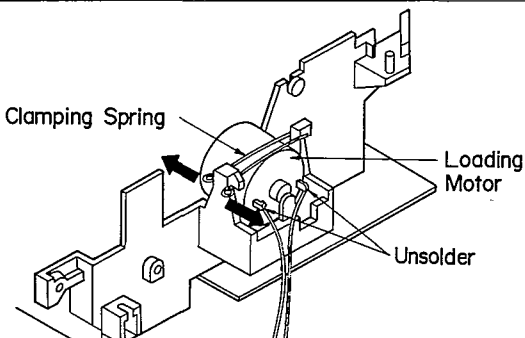
<p>Ref. No. 8</p>	<p>Removal of the holder and ring</p>	<p>Ref. No. 9</p>	<p>Removal of the disc holder</p>
<p>Procedure 1→7→8</p>	 <ol style="list-style-type: none"> 1. Pull out the holder in the direction of the arrow (A). 2. Remove the ring in the direction of the arrow (B). <p>Caution: Be sure to handle the small ball carefully.</p>	<p>Procedure 1→2→7→9</p>	 <ol style="list-style-type: none"> 1. Pull the disc holder slowly in the direction of the arrow until the disc tray comes up. 2. Pull the disc holder until it stops. 3. Push the bracket of tray SW (S1001) in the direction of the arrow. 4. Pull out the disc holder further to remove it.
<p>Ref. No. 10</p>	<p>Removal of the loading unit</p>	<p>Ref. No. 11</p>	<p>Removal of the servo P.C.B.</p>
<p>Procedure 1→2→7 →9→10</p>	 <ol style="list-style-type: none"> 1. Remove the 3 screws (1~3). 2. Remove the 3 connectors (CN12, CN401, CN431). 	<p>Procedure 1→2→7→ 9→10→11</p>	 <ol style="list-style-type: none"> 1. Remove the 4 screws (1~4). 2. Remove the FPC board (CN101) from the optical pickup. 3. Remove the 1 connector (CN102) of the turntable motor. <p>Caution: To prevent the breakdown of the laser diode, antistatic shorting pin is inserted into the FPC board.</p>
<p>Ref. No. 12</p>	<p>Removal of the loading motor</p>		
<p>Procedure 1→2→7 →9→12</p>	 <ol style="list-style-type: none"> 1. Remove the drive belt. 	 <ol style="list-style-type: none"> 2. Release the clamping spring. 3. Unsolder the 2 terminals of the lead wire of the loading motor. 	

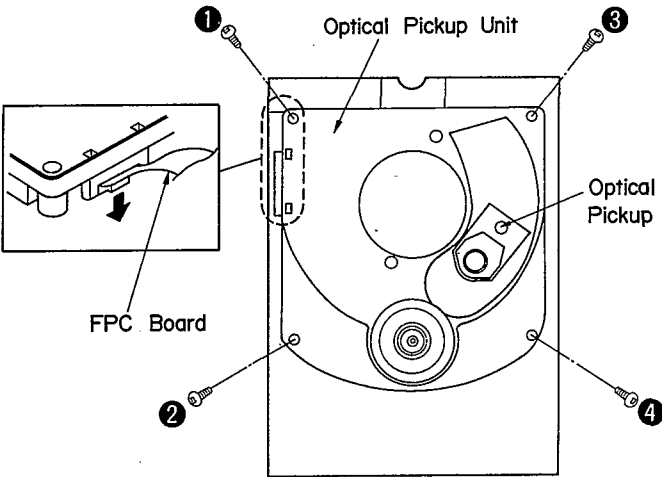
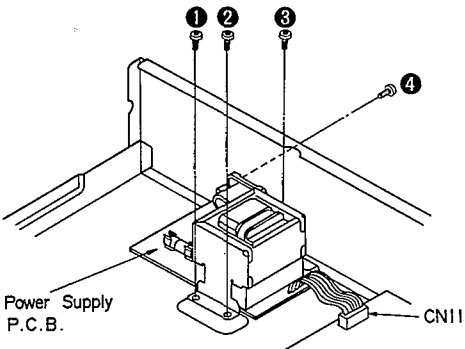
Ref. No. 13	Removal of the optical pickup unit	Ref. No. 14	Removal of the power supply P.C.B.
Procedure 1→2→7→9→ 10→11→13	 <p>1. Remove the 4 screws (①~④).</p> <p>2. Remove the FPC board from the optical pickup.</p>	Procedure 1→14	 <p>1. Remove the 4 screws (①~④).</p> <p>2. Remove the 1 connector (CN11).</p>

■ CHECKING OF THE SERVO P.C.B.

1. Remove the cabinet (see Ref. No. 1 of the disassembly instructions).
2. Remove the disc lid and disc holder (see Ref. No. 7 and No. 9 of the same).
3. Remove the loading unit (see Ref. No. 10 of the same).
4. When checking the soldered surface of the servo P.C.B. and replacing the parts, do as shown below.

(To play a disc)

1. Place the test disc.
2. Reinstall the disc lid to the loading unit.
3. Turn "ON" the power switch of the player.
4. Push the bracket of tray SW (S1001) in the direction of the arrow and release it.

Note: If the test disc fails to rotate, press the tray switch again.

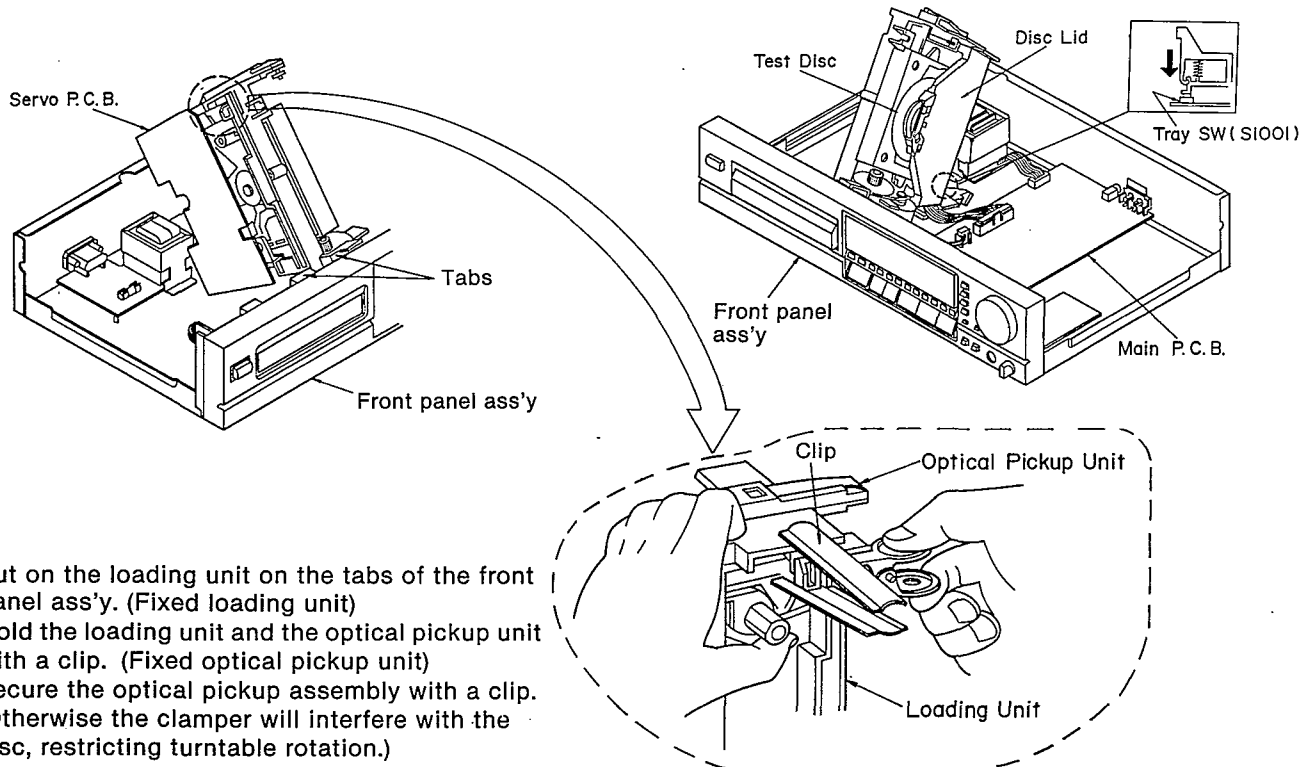

MEASUREMENTS AND ADJUSTMENTS

Caution:

1. It is very dangerous to look at or touch the laser beam. (Laser radiation is invisible.)
With the unit turned "on", laser radiation is emitted from the pickup lens.
Avoid exposure to the laser beam, especially when performing adjustments.
2. During laser power or focus offset adjustment, never connect the other probe to the unit.
(Otherwise the unit's power supply will sustain damage.)

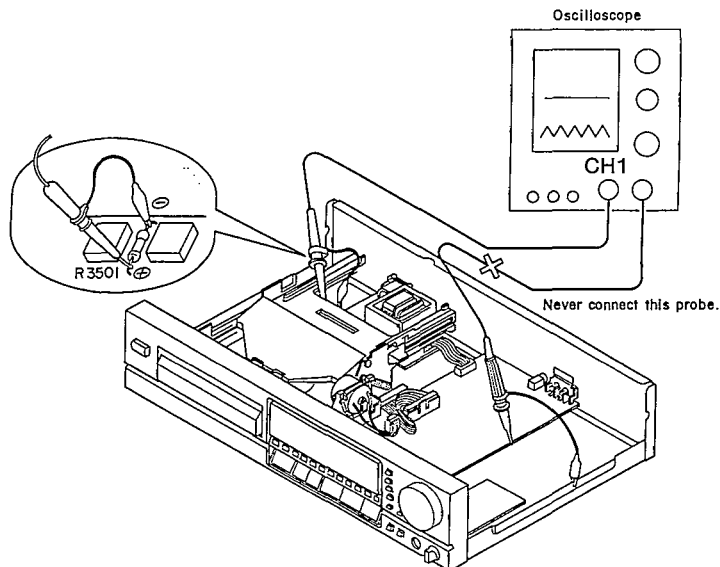

PREPARATION

1. Remove the cabinet (see Ref No. 1 of the disassembly instructions).
2. Remove the disc holder (see Ref No. 9 of the same).
3. Place the test disc on the turntable.
4. Turn "ON" the power switch at the player.
5. Push the bracket of tray SW (S1001) in the direction of the arrow and release it.

Note: If the test disc fails to rotate, press the tray switch again.

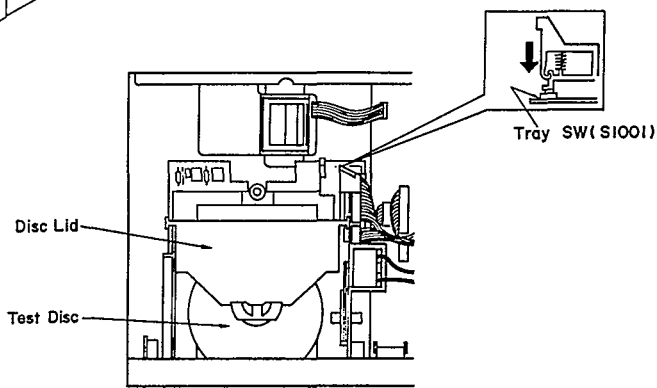

ADJUSTMENT POINTS

• Servo P.C.B.

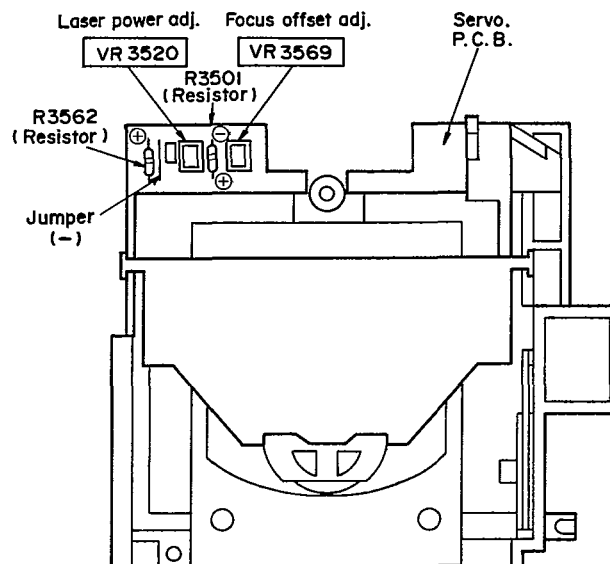

Measuring Instruments

- * Playability test disc (SZZP1054C).
- * Normal disc (Ordinary musical program disc).

- * Dual-beam oscilloscope with bandwidth of 30MHz or better (with EXT trigger and 1:1 probe).

(1) LASER POWER ADJUSTMENT

1. Connect the oscilloscope's CH1 probe across (+) and (-) of **R3501** (Resistor) on the servo P.C.B.
2. Switch the player power ON, and play track No. 1 on the test disc (SZZP1054C).
3. Adjust **VR3520** so that the voltage is $-50 \pm 2\text{mV}$.

Oscilloscope setting:

VOLT20mV
 SWEEP0.2msec.
 INPUTDC

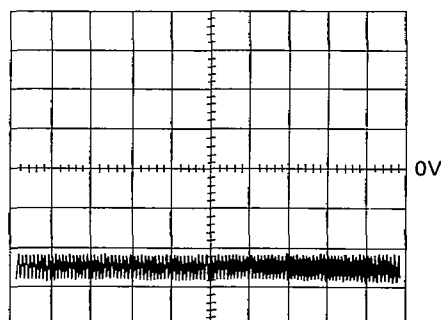

(2) FOCUS OFFSET ADJUSTMENT

1. Connect the oscilloscope's CH1 probe across **R3562** (Resistor) (+) and **Jumper** (-) on the servo P.C.B.
2. Switch the player power ON, and play track No. 1 on the test disc (SZZP1054C).
3. Adjust **VR3569** until the signal amplitude become in the center of **400mV**.

Oscilloscope setting:

VOLT200mV
 SWEEP5msec.
 INPUTDC

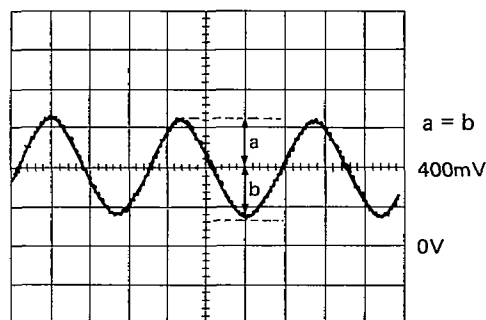

(3) CHECK OF PLAY OPERATION AFTER ADJUSTMENT

* Checking Skip Search

1. Play an ordinary musical program disc.
2. Press the skip button to check for normal skip search operation (in both the forward and reverse directions).

* Checking Manual Search

1. Play an ordinary musical program disc.
2. Press the manual search button to check for smooth manual search operations at either low or high speed (in both the forward and reverse directions).

* Playability check by test disc

1. Play the 0.7mm black dot and the 0.7mm wedge on the playability test disc (SZZP1054C) and verify that no sound skip or noise occurs.

■ TERMINAL FUNCTION OF IC'S

• IC6501 (482220973234/TDA8808T): Photo diode signal processor

Pin No.	Mark	I/O Division	Function
1	GCHF	I	Gain control input of HF amplifier. Current output from HF amplitude detector
2	Vp	I	Positive supply voltage
3	HFout	O	HF amplifier and equalizer voltage output
4	DET	I	HF detector voltage input
5	Sc	I	Starting up capacitor input
6	Si/RD	I/O	On/off control (start input); ready signal output (starting up procedure successful)
7	Beg	I	Equalizer reference current input
8	Bgc	I	DC and LF gain control reference current input
9	FOC START	I	Focus normalizing circuit starting current
10	PLLH	O	PLL on hold output
11	TL	O	Track loss output
12	DODS	I	Drop out detector suppression input
13	Vext	I	Negative supply connection for FE and FElag output stage; also substrate connection
14	LPF	O	Low pass filter for Iret, used in track loss (TL) detector and LF gain control

Pin No.	Mark	I/O Division	Function
15	FE	O	Current output of normalized, switched focus error signal
16	FElag	O	Current output of switched focus error signal, intended for lag network
17	LO	O	Laser amplifier current output
18	LM	I	Laser monitor diode input
19	GCLF	I	Gain control input for AC and LF amplifiers. Current output from LF amplitude detector
20	Re2	O	Summation of amplified currents from D3 and D4
21	Re1	O	Summation of amplified currents from D1 and D2
22, 23	D1, D2	I	Current inputs to DC and LF photo diode amplifier
24, 25	D3, D4	I	Current inputs to DC and LF photo diode amplifier
26	HFin	I	Current input to HF amplifier
27	GND	—	Ground connection of device
28	DEC	I	Decoupling input (internal bypass)

• IC6503 (482220973235/TDA8809T): Radial error signal processor

Pin No.	Mark	I/O Division	Function
1	Vp	I	Positive supply voltage
2	Cosc1	I	Frequency setting capacitors for oscillator
3	Cosc2		
4	Rwob	I	Wobble generator input
5	Rosc	I	Biassing resistor for oscillator frequency and internal amplitude
6	DIV4	I	Radial error digital signal divided by four
7	REdig	O	Digital output of sign (Re2 – Re1)
8	B3	I	Input control bits for off-, catch-, play-status and DAC output current
9	B2		
10	B1		
11	B0		
12	Vext (+)	I	Positive external voltage input
13	Vext (–)	I	Negative external voltage input (also substrate connection)
14	GND	—	GND terminal
15	RADout	O	Current output of amplified (Re2 – Re1) input currents
16	REin	I	Radial error input
17	RElag	O	Voltage output of integrated (Re2 – Re1) input currents

Pin No.	Mark	I/O Division	Function
18	Lag	I	Connection of integrator capacitor for (Re1 – Re2) input currents
19	Lead	O	Lead output
20	Vref	I	Internal reference voltage output
21	AGC	I	Gain control input for radial error signal
22	RDAC	O	Biassing resistor for current output for track jumping (3 ¹ / ₂ bits)
23	offset in	I	Offset control input for radial offset
24	offset off	O	Offset control output for radial offset
25	CLPF	I	Low-pass filter for Re1 and Re2, used for radial offset control
26	CHPF	I	High-pass filter for Re1 and Re2, used for radial offset control
27	Re1	I	Input for amplified currents from photo diodes D1 and D2
28	Re2	I	Input for amplified currents from photo diodes D3 and D4

• IC301 (MN6626): Digital signal processor

Pin No.	Mark	I/O Division	Function
1	AVSS	—	GND terminal
2	IREF	I	Reference current input
3	ARF	I	RF signal input
4	DRF	I	DSL bias terminal (Not used, open)
5	DSLIF	I/O	DSL loop filter terminal
6	PLLF	I/O	PLL loop filter terminal
7	AVDD	I	Power supply terminal
8	RSEL	I	RF signal polarity setting terminal (Not used, connected to VDD)
9 16	TBUS7 TBUS0	O	Test terminal
17	FLAG	O	Flag terminal
18	IPFLAG	O	Interpolation flag terminal
19	FCLK	O	Crystal frame clock (Not used, open)
20	BYTCK	O	Byte clock (Not used, open)
21	WDCK	O	Word clock (Not used, open)
22	RST	I	Reset terminal
23	TX	O	Digital audio signal (Not used, open)
24	LDG	O	Lch deglitch signal (Not used, open)
25	RDG	O	Rch deglitch signal (Not used, open)
26	SRDATA	O	Serial data output (MSB first)
27	SCK	O	Serial bit clock output
28	LRCK	O	L/R discriminating signal
29	XCK	O	Crystal OSC terminal (f=16.9344 MHz) (Not used, open)
30	PMCK	O	Frequency division clock signal (Not used, open) $(f = \frac{1}{192} \times CK = 88.2 \text{ kHz})$
31	CSEL	I	Test terminal (Connected to GND)
32	PSEL		
33	X1	I	Crystal OSC terminal (f=16.9344 MHz)
34	X2	O	
35	VSS	—	GND terminal
36	SUBQ	O	Sub-code Q data
37	SQCK	I	Sub-code Q register clock
38	CLDCK	O	Sub-code frame clock (f=7.35 kHz) (Not used, open)

Pin No.	Mark	I/O Division	Function
39	BLKCK	O	Sub-code block clock (f=75 Hz)
40	DEMPH	O	De-emphasis ON signal ("H": ON)
41	MEMP	I	Emphasis signal
42	MLD	I	Command load signal ("L": LOAD)
43	MCLK	I	Command clock signal
44	MDATA	I	Command data signal
45	D MUTE	I	Muting input ("H": MUTE)
46	SMCK	O	System clock (f=4.2336 MHz)
47	STAT	O	Status signal (CRC, CUE, CLVS, TTSTOP, FCLV, SQOK)
48	CRC	O	Sub-code CRC check terminal ("H": OK, "L": NG)
49	SUBC	O	Sub-code serial output data (Not used, open)
50	SBCK	I	Sub-code serial output clock (Not used, open)
51	TRON	I	Tracking servo ON signal ("L": ON)
52	CLVS	O	Turntable servo phase synchro signal ("H": CLV, "L": Rough servo)
53	PC	O	Turntable motor ON signal ("L": ON)
54	ECM	O	Turntable motor drive signal (Forced mode)
55	ECS	O	Turntable motor drive signal (Servo error signal)
56	VDD	I	Power supply terminal
57	TEST	I	Test terminal (Normal: "H")
58	SSEL	I	"SUBQ" terminal mode select ("H": Q code buffer)
59	MSEL	I	"SMCK" terminal frequency select ("L": SMCK=4.2336 MHz)
60	RESY	O	Re-synchronizing signal of frame sync. (Not used, open)
61	DO	I	Drop-out detection signal ("H": Drop-out) (Not used, connected to GND)
62	EFM	O	EFM signal (Not used, open)
63	PCK	O	PLL extract clock (f=4.3218 MHz) (Not used, open)
64	PDO	O	Phase compared signal of EFM and PCK (Not used, open)

• IC401 (MN1871617PMC): System control & FL drive

Pin No.	Mark	I/O Division	Function
1	VDD	I	Power supply terminal
2	OSC2	I	System clock input (f=4.2336MHz)
3	OSC1		
4	VSS	—	GND terminal
5	XI	I	Radial error digital signal
6	XO	O	Not Used, open
7	P47	I	
8 } 12	P46 } P42	I	Key return signal
13	SYNC REC	O	Synchro rec control
14	REC ENABLE	I	
15 } 18	P37 } P34	—	Not used, open and connected to terminal
19	P33	—	Not used, open and connected to terminal
20	P32		
21	P31		
22	P30		
23	P27		
24	OPEN/CLOSE	O	Loading motor control signal
25	DMUTE	O	Muting output ("H": MUTE)
26	SI/RD	I/O	On/off control and ready signal
27 } 30	B3 } B0	O	Control bits for off-, catch-, play-status and DAC output current
31	REMOCON	I	Remote control signal
32	REDIG	I	Radial error digital signal
33	MDATA	O	Command data signal
34	MCLK	O	Command clock signal
35	MLD	O	Command load signal ("L": LOAD)

Pin No.	Mark	I/O Division	Function
36	TL	I	Track loss input
37	RST	I	Reset terminal
38	SQCK	O	Sub-code Q register clock
39	SUBQ	I	Sub-code Q data
40	TRAY SW	I	Disc holder open/close det. terminal
41	BLKCK	I	Sub-code block clock (f=75 Hz)
42	DODS	O	Drop-out detect signal
43	STAT	I	Status signal (CRC, CUE, CLVS, TTSTOP, FCLV, SQOK)
44	P95	—	Not used, open
45	CLVS	I	Spindle servo phase synchro signal ("H": CLV, "L": Rough servo)
46	TRON	O	Tracking servo ON signal ("L": ON)
47	DIV4	O	Radial error digital signal divided by four
48	EMPH	O	Emphasis signal
49	HFD	I	PLL on hold input
50	CM	—	Not used, connected to GND
51	130Hz	—	Not used, open
52	VPP	I	Power supply terminal for FL drive
53 } 56	16G } 13G	—	Not used, open
57 } 68	12G } 1G	O	FL digit signal
69 } 84	A/SEGO } P/SEGP	O	FL segment signal and key scan signal

• IC801 (MN6474): Digital filter and D/A converter

Pin No.	Mark	I/O Division	Function
1	MLD	I	Command load input (load: L) (Not used, connected to VDD)
2	RSTB	I	Reset terminal
3	IE	I	Not used, connected to GND
4	TP1	—	TEST terminal
5	TP2	—	
6	TEST1	I	TEST terminal 1 (connected to GND)
7	TEST2	I	TEST terminal 2 (connected to GND)
8	NC	—	Not connected
9	NC	—	Not connected
10	AVDD4	I	Power supply terminal
11	OUTL (-)	O	Lch data output, (-) terminal
12	AVSS4	—	GND terminal
13	AVSS3	—	GND terminal
14	OUTL (+)	O	Lch data output, (+) terminal
15	AVDD3	I	Power supply terminal
16	NC	—	Not connected
17	AVDD2	I	Power supply terminal
18	OUTR (+)	O	Rch data output, (+) terminal
19	AVSS2	—	GND terminal (analog system)
20	AVSS1	—	GND terminal (analog system)
21	OUTR (-)	O	Rch data output, (-) terminal
22	AVDD1	I	Power supply terminal
23	DVDD1	I	Power supply terminal

Pin No.	Mark	I/O Division	Function
24	DVSS1	—	GND terminal (digital system)
25	X2	O	Crystal OSC terminal (33MHz)
26	X1	I	
27	NC	—	Not connected
28	DVDD2	I	Power supply terminal
29	DVSS2	—	GND terminal (digital system)
30	NSUB	I	Sub-strate terminal (Not used, connected to VDD)
31	ZFLGB	O	Zero input detector terminal (Not used, open)
32	192fs	O	192fs (8.4672MHz) (Not used, open)
33	LRPOL	I	LR clock selector (Not used, connected to VDD)
34	LRCLK	I	LR discrimination signal input
35	BCLK	I	Serial bit clock input
36	SRDATA	I	Serial data input (MSB first)
37	DVSS3	—	GND terminal (digital system)
38	DVDD	I	Power supply terminal
39	384fs	O	384fs (16.9344MHz) output
40	PD	I	Power down terminal (Not used, connected to GND)
41	MDATA	I	Mode control data (Not used, connected to VDD)
42	MCLK	I	Data clock for MDATA (not used, connected to VDD)

■ BLOCK DIAGRAM

Note)
• → Audio signal.

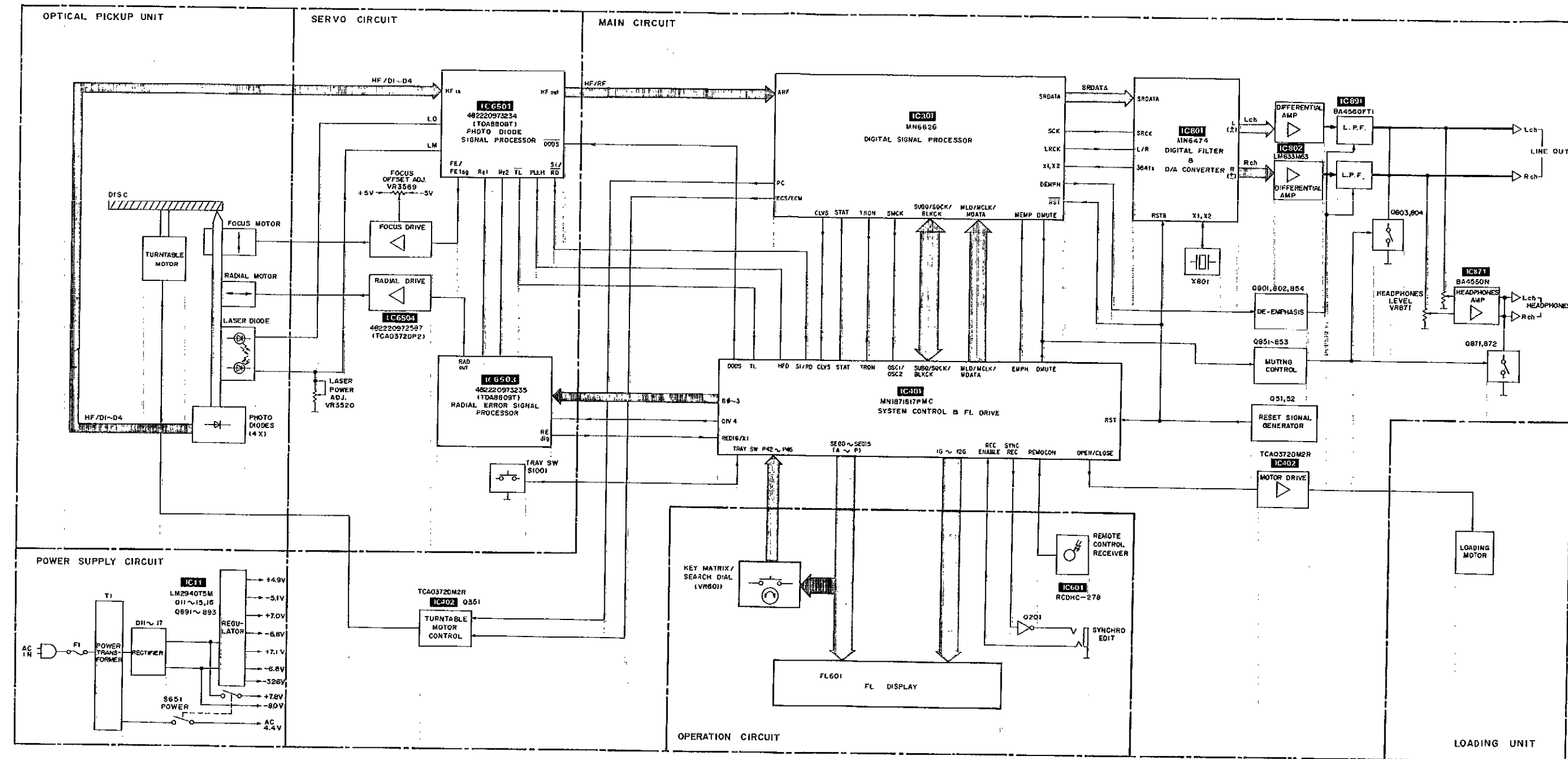

RAD out : Current output of Integrated (Re2-Re1) input currents.
 B0~B3 : Control bits for radial circuit.
 D0DS : Drop out detect signal.
 D1~D4 : Photodiode currents.
 FE : Focus error signal.
 FE lag : Radial error signal for LAG network.
 HF out : HF amplifier and equalizer voltage output.
 HFIn : HF current input.
 LM : Laser monitor diode input.
 LO : Laser amplifier current output.
 Re1 : Radial error signal 1 (summation of amplified currents D3 and D4).
 Re2 : Radial error signal 2 (summation of amplified currents D1 and D2).

RE dig : Radial error digital. (RE DIG/X1)
 RE lag : Radial error signal for LAG network.
 SI/RD : On/off control for laser supply and focus circuit.
 TL : Track loss signal.
 Div4 : Radial error digital divided by four.
 HF/RF/ARF : RF (Audio) signal.
 TRAY SW : Disc holder open/close det. terminal.
 CLVS : Spindle servo phase synchro signal.
 STAT : Status command for CRC etc.
 DMUTE : Data mute command.
 MDATA : Mode control data.
 MLD : Load command for mode control data (Active Low).

P42~46 : Key return signal.
 1G~12G : FL digit signal.
 SEG0~15 : FL segment signal and key scan signal.
 MCLK : Data clock for MDATA.
 SUBQ : Sub-code Q data.
 CLDCK : Data frame clock (7.35KHz).
 BLKCK : RF (Audio) signal.
 SQCK : Sub-code Q data block clock (75Hz).
 RST : Sub-code Q register clock.
 (RSTB) : Reset command (Active Low).
 TRON : Tracking servo ON command (Active Low).
 ECS/ECM : Turntable motor drive signal.
 PC : Turntable motor ON command (Active Low).
 SMCK : System clock (4.2336MHz).

LRCK/L/R : L/R data discrimination clock (88.2KHz).
 SRDATA : Serial data output (MSB first).
 SCK : Serial bit clock (2.82MHz). (SRCK)
 MEMP/EMPH : De-emphasis command (Active High).
 SYNC REC/ : Synchro rec control.
 REC ENABLE : Remote control signal.
 REMOCON : Remote control signal.
 384fs/X1, X2 : 384fs (16.9344MHz) signal.
 DEMPH : De-emphasis ON signal.
 L (±) : Lch data signal.
 R (±) : Rch data signal.
 OPEN/CLOSE : Loading motor control signal.

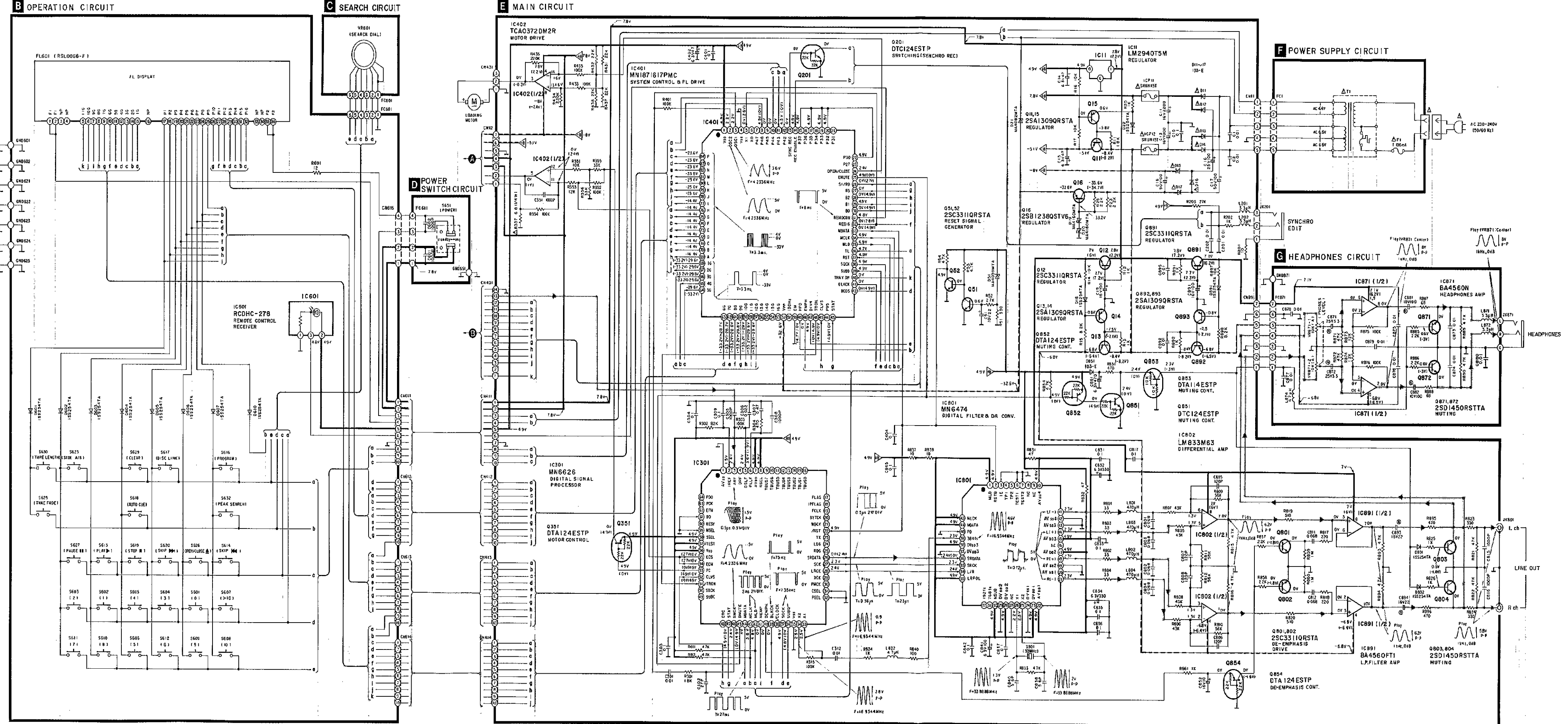

TERMINAL GUIDE OF IC'S, TRANSISTORS AND DIODES

BA4560FT1	LM833M63	TCA0372DM2R
482220973234 (TDA8808T)	482220973235 (TDA8809T)	482220972587 (TCA0372DP2)
MN6474	MN6626	MN1871617PMC
BA4560N	LM2940T5M	RCDHC-278
1. Vin 2. GND 3. Vout		
DTA114ESTP DTA124ESTP DTC124ESTP		2SA1309QRSTA 2SC3311QRSTA 2SD1450RSTTA
2SB1238QSTV6	482213044121 (BC338)	1SS254TA
Cathode	Anode	Cathode
1D3-E	MA4039MTA MA4082MTA	MA4160MTA 482213081101 (HZ7C2)
Cathode	Cathode	Cathode
Anode	Anode	Anode

PRINTED CIRCUIT BOARDS

A SERVO P.C.B.

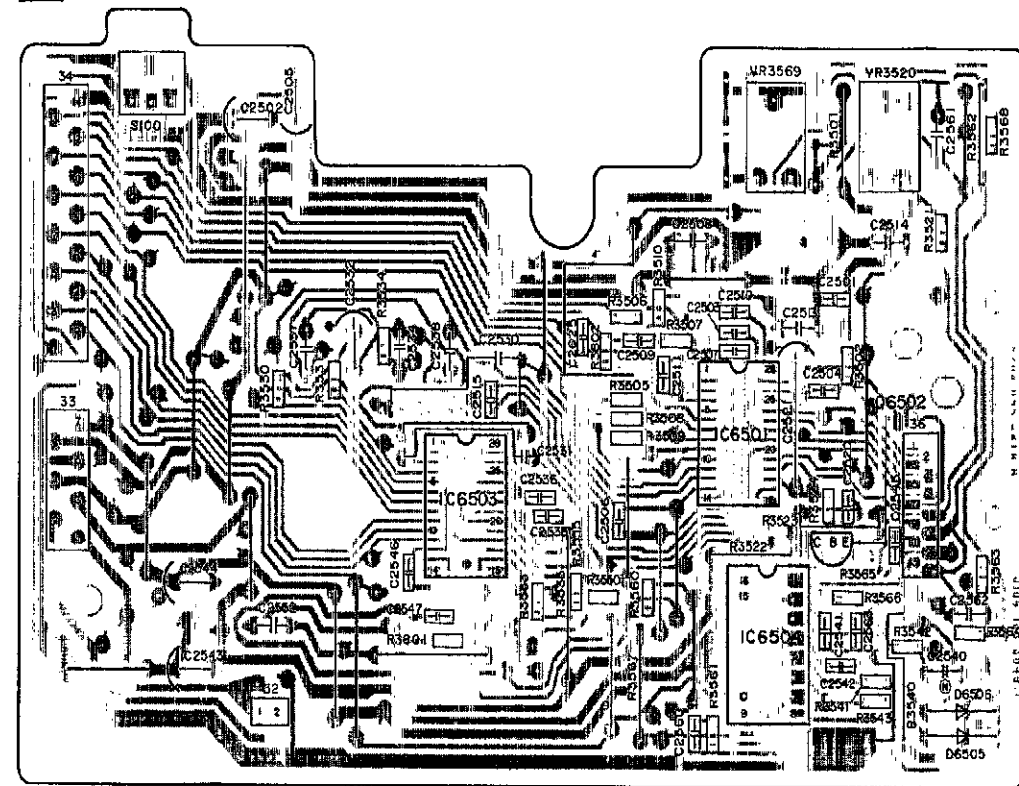

B OPERATION P.C.B.

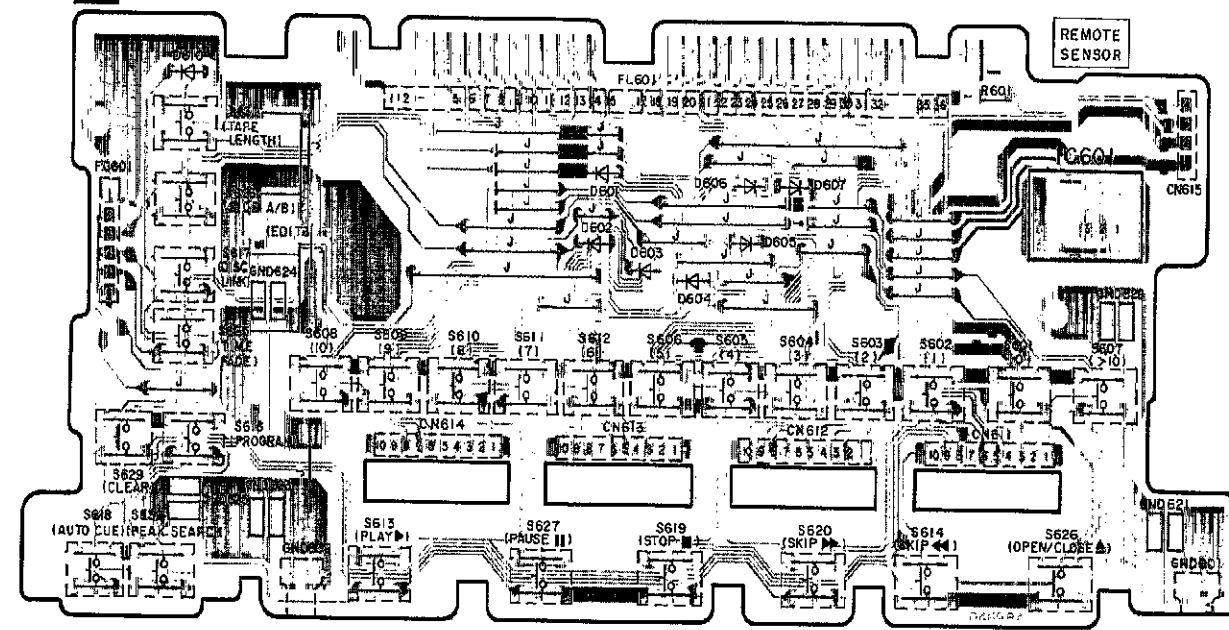

C SEARCH P.C.B.

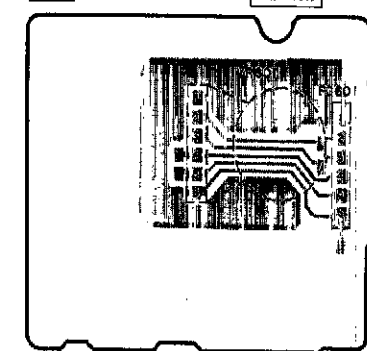

F POWER SUPPLY P.C.B.

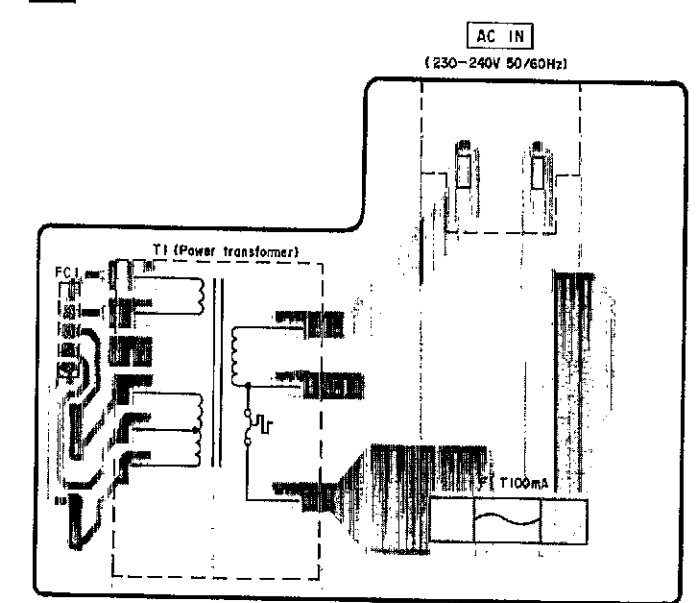

E MAIN P.C.B.

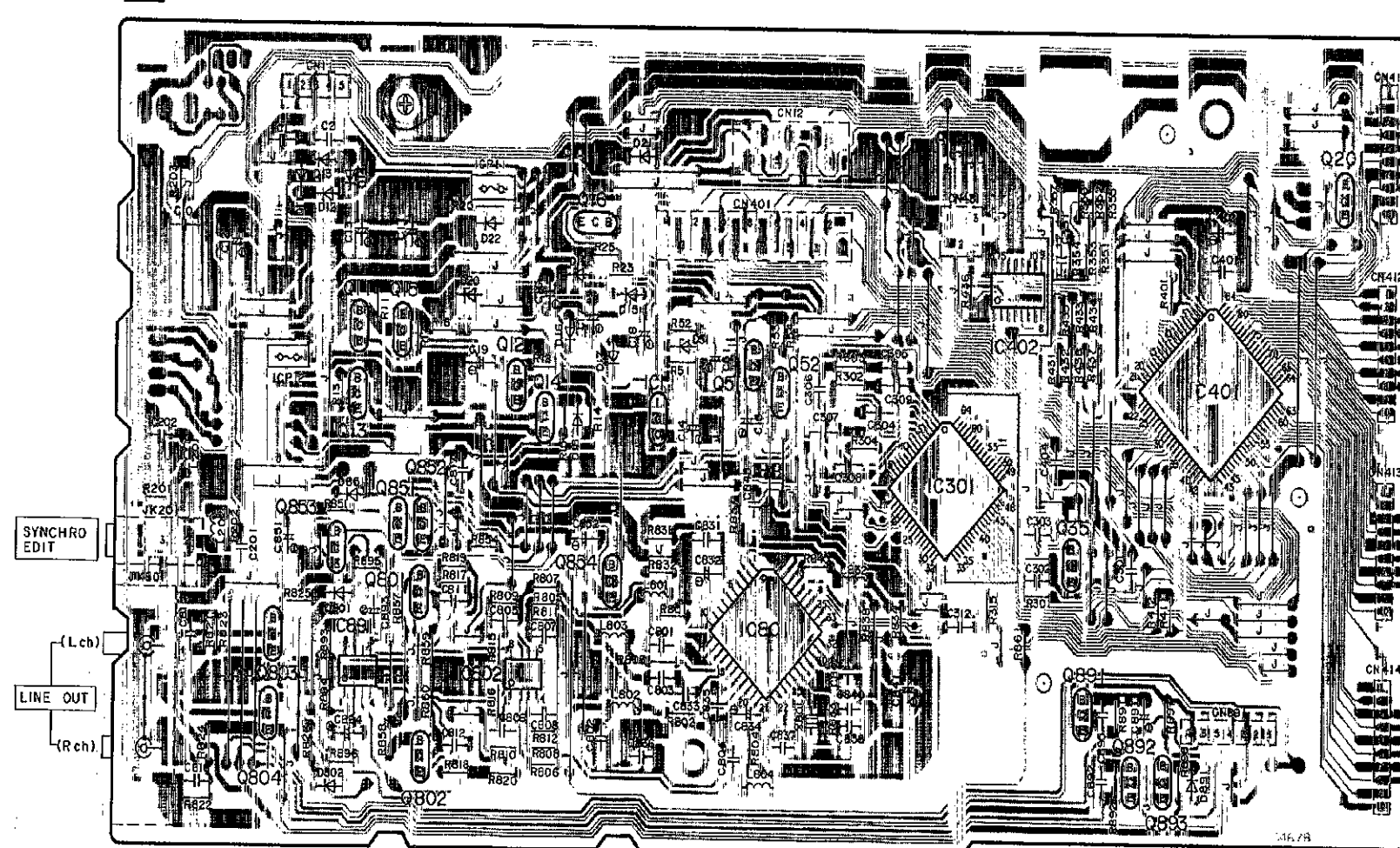

D POWER SWITCH P.C.B.

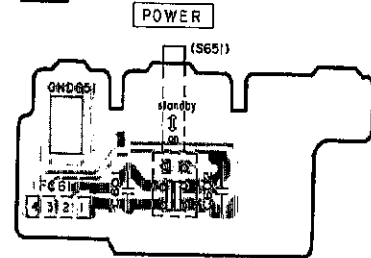

G HEADPHONES P.C.B.

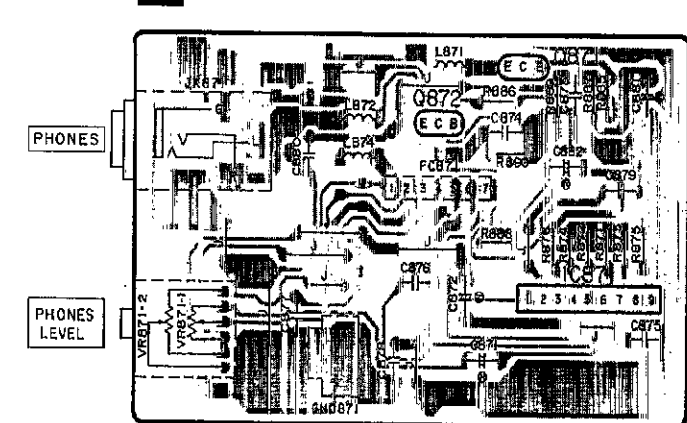

Note: Use connector pins to check servo circuit voltages and waveforms.

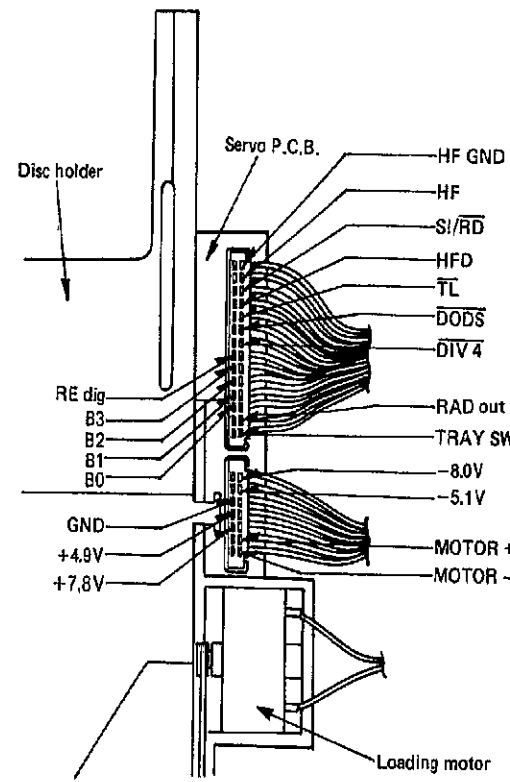

WIRING CONNECTION DIAGRAM

Notes:

BRN Brown
BLK Black

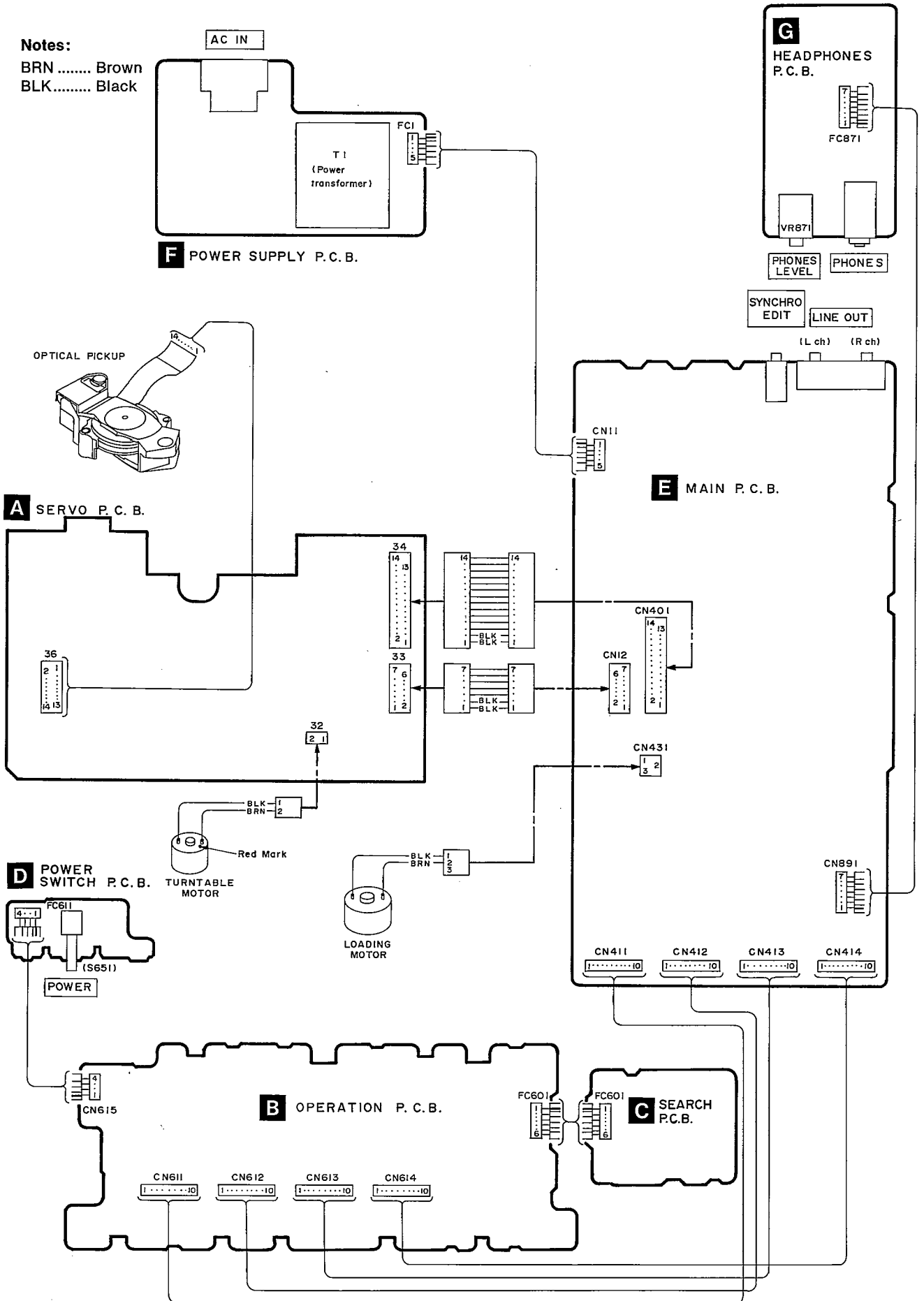

REPLACEMENT PARTS LIST

Notes: * Important safety notice:

Components identified by Δ mark have special characteristics important for safety. When replacing any of these components use only manufacturer's specified parts.

* The parenthesized indications in the Remarks columns specify the areas. (Refer to the cover page for area.)

Parts without these indications can be used for all areas.

* Remote Control Ass'y: Supply period for three years from termination of production.

* **[MB]** Indicates in Remarks columns parts that are supplied by MBV.

* **"(K)"** mark parts are used for black type only. **"(S)"** mark parts are used for silver type only.

Parts other than **"(K)"** and **"(S)"** marked are used for all color types.

* Warning: This product uses a laser diode. Refer to caution statements on page 3.

* ACHTUNG: Die lasereinheit nicht zerlegen.

Die lasereinheit darf nur gegen eine vom hersteller spezifizierete einheit ausgetauscht werden.

Ref. No.	Part No.	Part Name & Description	Remarks	Ref. No.	Part No.	Part Name & Description	Remarks
		INTEGRATED CIRCUIT(S)				IC PROTECTOR(S)	
IC11	LM2940T5	IC, REGULATOR		ICP11, 12	SRUN15	IC PROTECTOR	Δ
IC301	MN6626	IC, DIGITAL SIGNAL PROCESS.				VARIABLE RESISTOR(S)	
IC401	MN1871617PMC	IC, SYSTEM CONTROL&FL DRIVE	[MB]				
IC402	TCA0372DM2R	IC, MOTOR DRIVE		VR601	EVQ#VN00004E	V. R. SEARCH DIAL	
IC601	RCDHC-278	IC, REMOTE CONTROL RECEIVER		VR871	EVJCB0F02A14	V. R. HEADPHONES LEVEL	
IC801	MN6474	IC, DIGITAL FILTER&D/A CONV.				COIL(S)	
IC802	LM833M63	IC, DIFFERENTIAL AMP		L201, 202	RLQZN3R3KL-D	COIL	[MB]
IC871	BA4560N	IC, HEADPHONES AMP		L801-804	RLQZN471KL-D	COIL	[MB]
IC891	SV1BA4560FT1	IC, L. P. FILTER AMP		L832	RLQZN4R7KL-D	COIL	
		TRANSISTOR(S)		L871, 872	RLQZN3R3KL-D	COIL	[MB]
				L874	RLQZN4R7KL-D	COIL	
Q11	2SA1309A-R	TRANSISTOR				TRANSFORMER(S)	
Q12	2SC3311A-Q	TRANSISTOR		T1	RTP1K4E013	TRANSFORMER	[MB] Δ
Q13-15	2SA1309A-R	TRANSISTOR				OSCILLATOR(S)	
Q16	2SB1238QSTV6	TRANSISTOR					
Q51, 52	2SC3311A-Q	TRANSISTOR		X801	RSXA33M8J01T	OSCILLATOR	[MB]
Q201	DTC124EST	TRANSISTOR				DISPLAY TUBE	
Q351	DTA124ESTP	TRANSISTOR		FL601	RSL0066-F	DISPLAY TUBE	[MB]
Q801, 802	2SC3311A-Q	TRANSISTOR				FUSE(S)	
Q803, 804	2SD1450RTA	TRANSISTOR		F1	XBA2C01TBO	FUSE 250V T100mA	Δ
Q851	DTC124EST	TRANSISTOR				SWITCH(ES)	
Q852	DTA124ESTP	TRANSISTOR		S601	EVQPCA05R	SW, NUMERIC 0	[MB]
Q853	DTA114ESTP	TRANSISTOR		S602	EVQPCA05R	SW, NUMERIC 1	[MB]
Q854	DTA124ESTP	TRANSISTOR		S603	EVQPCA05R	SW, NUMERIC 2	[MB]
Q871, 872	2SD1450RTA	TRANSISTOR		S604	EVQPCA05R	SW, NUMERIC 3	[MB]
Q891	2SC3311A-Q	TRANSISTOR		S605	EVQPCA05R	SW, NUMERIC 4	[MB]
Q892, 893	2SA1309A-R	TRANSISTOR		S606	EVQPCA05R	SW, NUMERIC 5	[MB]
		DIODE(S)		S607	EVQPCA05R	SW, NUMERIC >10	[MB]
				S608	EVQPCA05R	SW, NUMERIC 10	[MB]
D11-17	1D3-E	DIODE	[MB] Δ	S609	EVQPCA05R	SW, NUMERIC 9	[MB]
D18	1SS254TA	DIODE					
D19, 20	MA4160M	DIODE					
D21	MA4082MTA	DIODE					
D22	1SS254TA	DIODE					
D51	MA4039MTA	DIODE					
D601-607	1SS254TA	DIODE					
D610	1SS254TA	DIODE					
D801, 802	1SS254TA	DIODE					
D851	1D3-E	DIODE	[MB]				
D891	1SS254TA	DIODE					

Ref. No.	Part No.	Part Name & Description	Remarks	Ref. No.	Part No.	Part Name & Description	Remarks
S610	EVQPCA05R	SW, NUMERIC 8	[MB]			INTEGRATED CIRCUIT(S)	
S611	EVQPCA05R	SW, NUMERIC 7	[MB]				
S612	EVQPCA05R	SW, NUMERIC 6	[MB]	IC6501	482220973234	I. C, PHOTO DIODE S. P.	[MB]
S613	EVQPCA05R	SW, PLAY	[MB]	IC6503	482220973235	I. C, RADIAL ERROR S. P.	[MB]
S614	EVQPCA05R	SW, SKIP (B)	[MB]	IC6504	482220972587	I. C, FOCUS/RADIAL DRIVE	[MB]
S616	EVQPCA05R	SW, PROGRAM	[MB]			TRANSISTOR(S)	
S617	EVQPCA05R	SW, LINK	[MB]				
S618	EVQPCA05R	SW, AUTO CUE	[MB]				
S619	EVQPCA05R	SW, STOP	[MB]	Q6502	482213044121	TRANSISTOR	[MB]
S620	EVQPCA05R	SW, SKIP (F)	[MB]			DIODE(S)	
S623	EVQPCA05R	SW, SIDE A/B	[MB]				
S625	EVQPCA05R	SW, TIME FADE	[MB]				
S626	EVQPCA05R	SW, OPEN/CLOSE	[MB]	D6505	482213030861	DIODE	[MB]
S627	EVQPCA05R	SW, PAUSE	[MB]	D6506	482213030861	DIODE	[MB]
S629	EVQPCA05R	SW, CLEAR	[MB]			VARIABLE RESISTOR(S)	
S630	EVQPCA05R	SW, EDIT	[MB]				
S632	EVQPCA05R	SW, PEAK SEARCH	[MB]	VR3520	482210110685	V. R, LASER POWER ADJ.	[MB]
S651	RSP2B010	SW, POWER		VR3569	482210011193	V. R, FOCUS OFFSET ADJ.	[MB]
		CONNECTOR(S) & SOCKET(S)				SWITCH	
CN11	RJS1A6605	CONNECTOR (5P)					
CN12	RJT001H007	CONNECTOR (7P)	[MB]	S1001	482227612523	SW, TRAY	[MB]
CN401	RJT001H014	CONNECTOR (14P)	[MB]				
CN411-414	RJU003K010M1	SOCKET (10P)					
CN431	RJT001H003	CONNECTOR (3P)	[MB]				
CN611-614	RJT003K010M1	CONNECTOR (10P)					
CN615	RJS1A6604	CONNECTOR (4P)					
CN891	RJS1A6607	CONNECTOR (7P)	[MB]				
		JACK(S)					
JK201	RJJ33T01	SYNCHRO EDIT					
JK801	RJH3201N	LINE OUT					
JK871	QJA0455ZC-A	HEADPHONES					
		EARTH CONTACT(S)					
GND601, 602	SUSD144	EARTH CONTACT					
GND621-625	EYFAT	EARTH CONTACT	(S)				
GND651	RMCO108	EARTH CONTACT	(S)				
GND871	RMCO075	EARTH CONTACT	[MB]				
		FLAT CABLE(S)					
FC1	RWJ1805100KX	FLAT CABLE (5P)	[MB]				
FC601	RWJ0906050XX	FLAT CABLE (6P)	[MB]				
FC611	RWJ1804200XX	FLAT CABLE (4P)	[MB]				
FC871	RWJ1807130KX	FLAT CABLE (7P)	[MB]				
		<SERVO P. C. B. >					

Ref. No.	Part No.	Part Name & Description	Remarks	Ref. No.	Part No.	Part Name & Description	Remarks
		CABINET AND CHASSIS					
1	RKMO152-K	CABINET	(K) MB	101	482244450603	DISC HOLDER	MB
1	RKMO152-S	CABINET	(S) MB	102	482232550176	GROMMET, CABLE	MB
2	SNE2129-1	SCREW	(K)	103	482232550177	GROMMET, CABLE	MB
2	SNE2129	SCREW	(S)	104	482246692251	DISC TRAY	MB
3	XTBS3+8JFZ1	SCREW		106	482235810115	DRIVE BELT	MB
4	EYF52BC	FUSE HOLDER		107	482252232359	WHEEL, GEAR	MB
5	SJS9236	AC INLET	△	108	482253251518	RING, RUBBER	MB
6	REX0007	CONNECTOR ASS' Y(7P)	MB	109	482240261081	GUIDE	MB
7	REX0285	CONNECTOR ASS' Y(14P)	MB	111	482240261132	GUIDE	MB
8	RGK0467-K	TRAY ORNAMENT	(K) MB	112	482252890638	ROLLER	MB
8	RGK0325-S	TRAY ORNAMENT	(S) MB	113	482249251902	SPRING, COMPRES.	MB
9	RFKHLPG520AE	REAR PANEL ASS' Y	(E, EG) MB	114	482246661587	FOAM	MB
9	RFKHPG520AEB	REAR PANEL ASS' Y	(EB) MB	116	482240261107	LEVER	MB
10	RKA0040B	FOOT	MB	117	482249263659	SPRING, BLADE	MB
11	RMK0077A	CHASSIS	MB	118	482244460568	DISC LID	MB
12	RMRO020	SPACER(A)	MB	119	482249232883	SPRING, TENSION	MB
13	RMRO021	SPACER(B)	MB	121	482252890639	ROLLER	MB
14	RMRO573-K	SPACER(C)	MB	122	482246692257	PLATE	MB
15	RMRO377	P. C. B. SUPPORT	MB	123	482240261207	HOLDER	MB
16	RMRO556-K	FL HOLDER	MB	124	482252040177	SMALL BALL	MB
17	RGU0030	POWER BUTTON	(K)	126	482253080503	RING, PRESSURE	MB
17	RGU0030-S	POWER BUTTON	(S)	127	482269130209	OPTICAL PICKUP UNIT	MB
18	RFKGGPG520AEK	FRONT PANEL ASS' Y	(K) MB	128	482240261196	SUPPORT	MB
18	RFKGGPG520AES	FRONT PANEL ASS' Y	(S) MB	129	482249263746	CLAMPING SPRING	MB
18-1	RMRO378	HEADPHONES HOLDER	MB	131	482236120998	LOADING MOTOR	MB
19	RGU0467A-K2	MAIN KNOB	(K)	132	482240250244	BRACKET	MB
19	RGU0467B-S1	MAIN KNOB	(S) MB	133	482249251935	SPRING, COMPRES.	MB
20	RGU0486-K	EDIT KNOB	(K) MB	134	482270112729	CHASSIS	MB
20	RGU0486-S	EDIT KNOB	(S) MB			PACKING MATERIAL	
21	XTBS26+8J	SCREW		P1	RPG1138	PACKING CASE	(K) MB
22	SHR328	FASTENER		P1	RPG1139	PACKING CASE	(S) MB
23	XTB3+20JFZ	SCREW		P2	RPN0429-1	CUSHION	MB
24	XTB3+35JFZ	SCREW		P3	RMRO024	LOCK SHAFT	MB
25	XTB3+8JFZ	SCREW		P4	RQCA0059	LOCK CAUTION SHEET	MB
26	RQLS0022	LASER CAUTION LABEL	MB	P5	XZB60X65A01Z	PROTECTION BAG	
27	RGW0048	H. P. VOLUME KNOB	(K)	P6	XZB23X35C03	PROTECTION BAG (F. B.)	
27	RGW0048-S	H. P. VOLUME KNOB	(S)	P7	XZB26X17C03	PROTECTION BAG (CORD)	
28	RGU0278B-K3	TEN KEY KNOB	(K) MB			ACCESSORIES	
28	RGU0278C-S3	TEN KEY KNOB	(S) MB	A1	RFKSLPG520AE	INSTRUCTION MANUAL ASS' Y	(E) MB
29	CSTW-2	RETAINING RING		A1	RQT1392-B	INSTRUCTION MANUAL	(EB) MB
30	RGW0146-K	SHUTTLE KNOB	(K) MB	A1	RQT1393-D	INSTRUCTION MANUAL	(EG) MB
30	RGW0146-S	SHUTTLE KNOB	(S) MB	A2	RJA0018-K	AC POWER SUPPLY CORD	(E, EG) △
31	SHRD202	SPRING HOLDER		A2	SJA193	AC POWER SUPPLY CORD	(EB) △
32	SHR9451	PRASTIC BEARING		A3	RQA0013	WARRANTY CARD	
33	SNE4021	NUT		A4	RQCB0169	SERVICENTER LIST	
34	SUSD162-1	RETURN SPRING		A5	SJP2249-3	STEREO CONNECTION CABLE	
35	RQLS0060	LASER CAUTION LABEL	MB	A6	EUR64798	REMOTE CONTROL TRANSMITTER	(K) MB
		LOADING UNIT PARTS		A6	EUR64799	REMOTE CONTROL TRANSMITTER	(S) MB
				A6-1	UR64EC804	BATTERY COVER	(K)
				A6-1	UR64EC804A	BATTERY COVER	(S)

EXPLODED VIEWS

• Cabinet and chassis parts

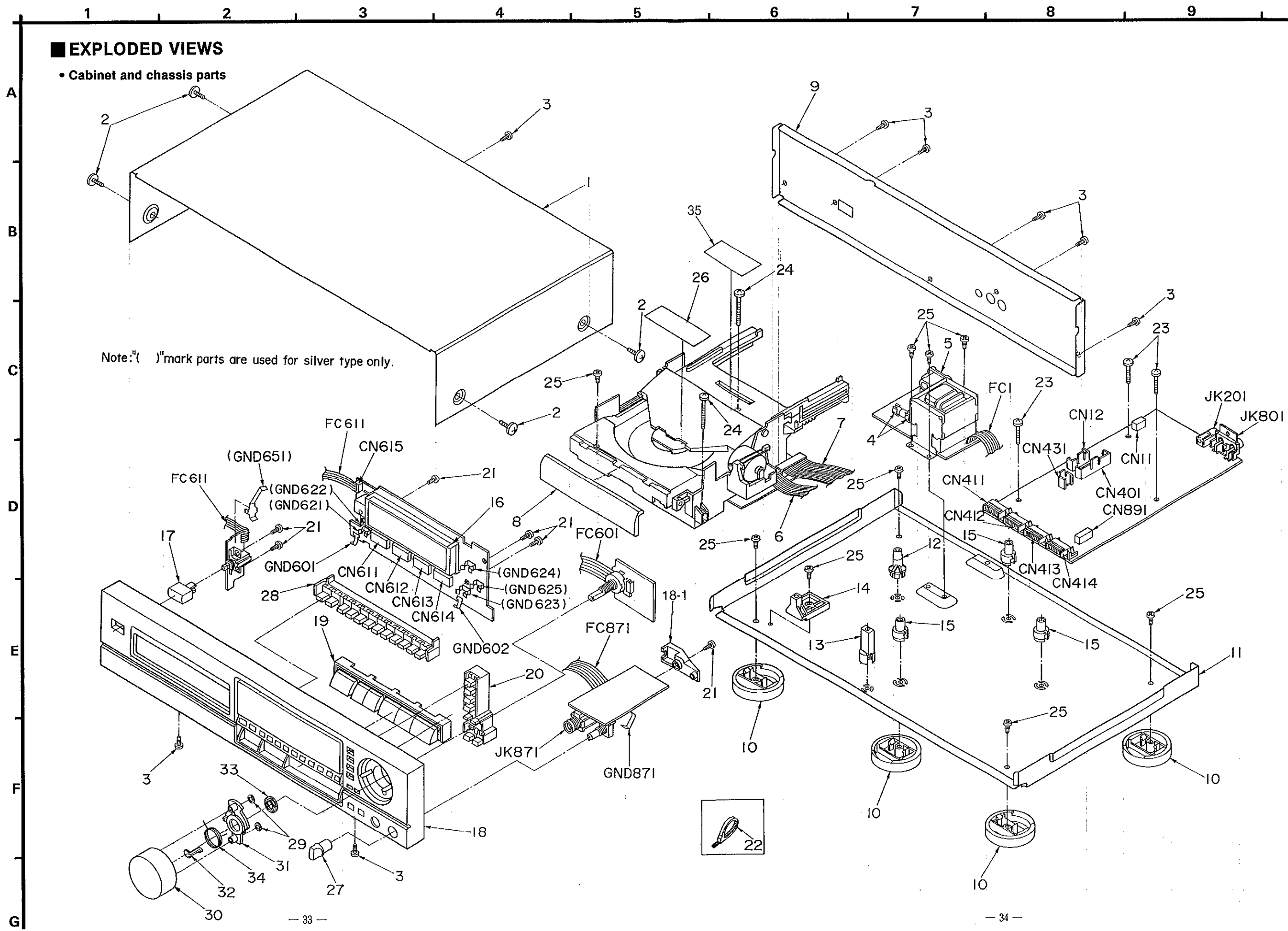

Note: () mark parts are used for silver type only.

• Loading unit part

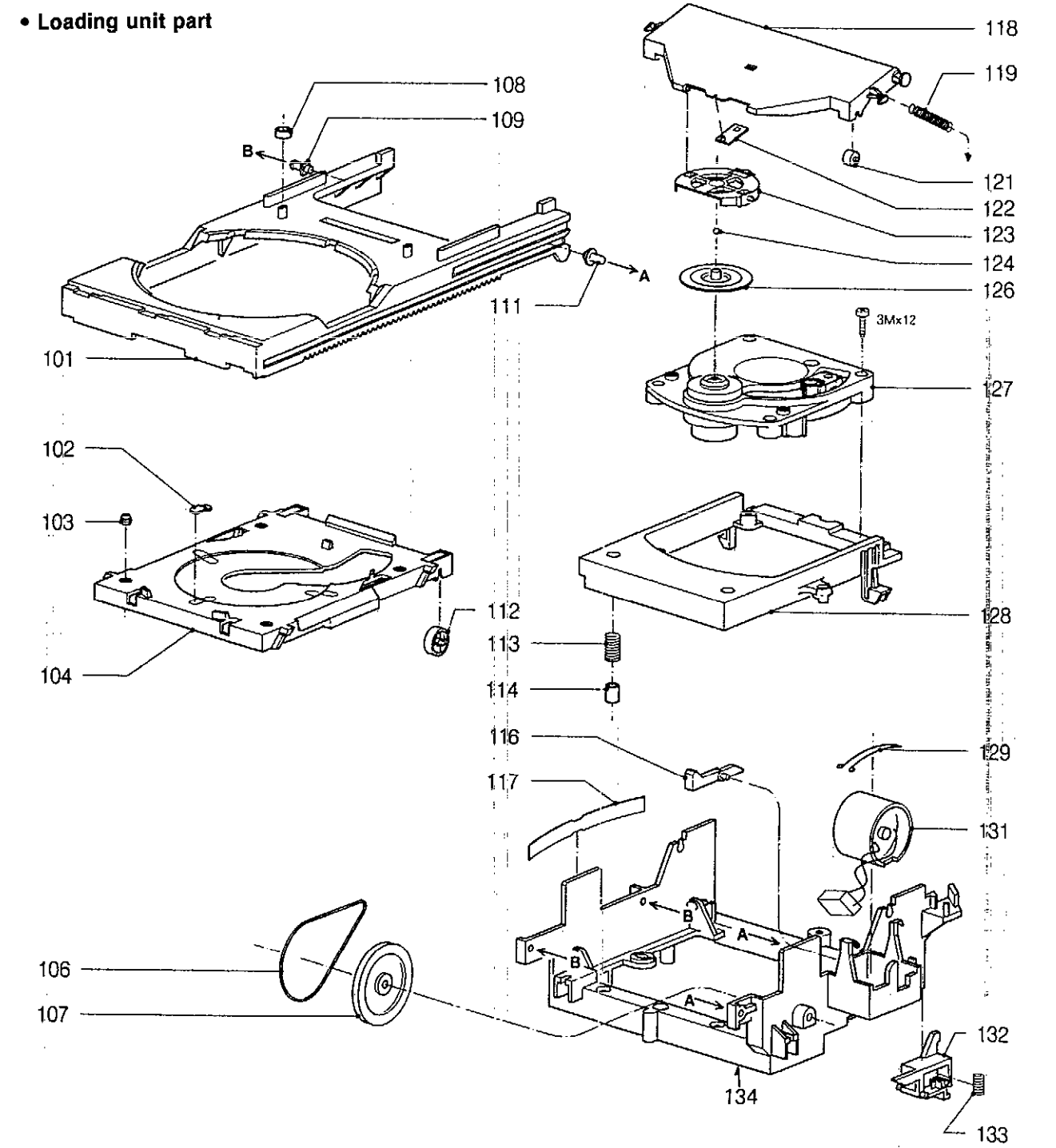

• Grounding for electrostatic breakdown prevention

1. Human body grounding
Use the anti-static wrist strap to discharge the static electricity from your body.
2. Work table grounding
Put a conductive material (sheet) or steel sheet on the area where the optical pickup is placed, and ground the sheet.

Caution:
The static electricity of your clothes will not be grounded through the wrist strap. So, take care not to let your clothes touch the optical pickup.

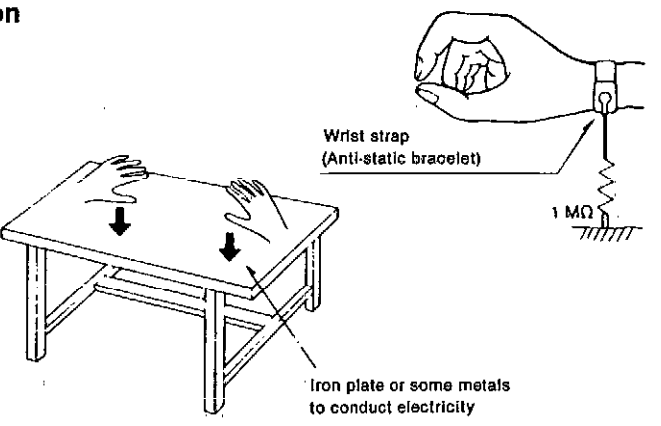

■ TROUBLESHOOTING GUIDE

■ RESISTORS & CAPACITORS

Notes : * Capacity values are in microfarads (uF) unless specified otherwise, P=Pico-farads (pF) F=Farads (F)
 * Resistance values are in ohms, unless specified otherwise, 1K=1,000(OHM) , 1M=1,000K(OHM)
 * [MB] indicates in Remarks columns parts that are supplied by MBV.

Ref. No.	Part No.	Values & Remarks	Ref. No.	Part No.	Values & Remarks	Ref. No.	Part No.	Values & Remarks
RESISTORS								
R11	ERDS2TJ182	1/4W 1.8K	R837, 838	ERDS2TJ100	1/4W 10	C817	ECFRIE104ZF5	25V 0.1U
R12, 13	ERDS2TJ102	1/4W 1K	R840	ERDS2TJ101	1/4W 100	C831	ECFRIE104ZF5	25V 0.1U
R14	ERDS2TJ103	1/4W 10K	R851	ERDS2TJ471	1/4W 470	C832	ECEAOJU331B	6.3V 330U
R15	ERDS2TJ822	1/4W 8.2K	R854	ERDS2TJ472	1/4W 4.7K	C833	ECFRIE104ZF5	25V 0.1U
R16, 17	ERDS2TJ103	1/4W 10K	R857, 858	ERDS2TJ222	1/4W 2.2K	C834	ECEAOJU331B	6.3V 330U
R20	ERDS2TJ102	1/4W 1K	R859, 860	ERDS2TJ105T	1/4W 1M	C835-837	ECFRIE104ZF5	25V 0.1U
R23	ERDS2TJ222	1/4W 2.2K	R861	ERDS2TJ102	1/4W 1K	C838	ECBT1H5R6K5	50V 5.6P
R25	ERDS2TJ222	1/4W 2.2K	R871, 872	ERDS2TJ473	1/4W 47K	C840	ECBT1H5R6K5	50V 5.6P
R51	ERDS2TJ331	1/4W 330	R873, 874	ERDS2TJ123	1/4W 12K	C841	ECEAOJKA101B	6.3V 100U
R52	ERDS2TJ272T	1/4W 2.7K	R875, 876	ERDS2TJ104	1/4W 100K	C842	ECFRIE104ZF5	25V 0.1U
R53, 54	ERDS2TJ472	1/4W 4.7K	R885, 886	ERDS2TJ222	1/4W 2.2K	C845	ECFRIE104ZF5	25V 0.1U
R201	ERDS2TJ100	1/4W 10	R887, 888	ERDS2TJ680T	1/4W 68	C851	ECEAOJU471	6.3V 470U
R202	ERDS2TJ102	1/4W 1K	R889, 890	ERDS2TJ472	1/4W 4.7K	C852	ECEA1CKA100B	16V 10U
R203	ERDS2TJ273	1/4W 27K	R891, 892	ERDS2TJ102	1/4W 1K	C871, 872	ECEA1EK3R3B	25V 3.3U
R301	ERDS2TJ182	1/4W 1.8K	R893, 894	ERDS2TJ472	1/4W 4.7K	C873, 874	ECQB1H103K3	50V 0.01U
R302	ERDS2TJ823T	1/4W 82K	R895, 896	ERDS2TJ471	1/4W 470	C875-880	ECBT1C103NS5	16V 0.01U
R303	ERDS2TJ104	1/4W 100K	R897	ERDS2TJ103	1/4W 10K	C881, 882	ECEALAN101X5	10V 100U
R304	ERDS2TJ471	1/4W 470	R898	ERDS2TJ822	1/4W 8.2K	C891	ECEA1CKA101B	16V 100U
R315	ERDS2TJ104	1/4W 100K	CAPACITORS			C892	ECBT1C103NS5	16V 0.01U
R351	ERDS2TJ103	1/4W 10K	C1, 2	ECFTD103KXL	50V 0.01U	C893, 894	ECEA1CKN220B	16V 22U
R352	ERDS2TJ104	1/4W 100K	C10	ECFRIE104ZF5	25V 0.1U	C895	ECBT1C103NS5	16V 0.01U
R353	ERDS2TJ123	1/4W 12K	C11	ECA1CM222B	16V 2200P	RESISTORS		
R354	ERDS2TJ104	1/4W 100K	C12	ECEA1CU102	16V 1000U	R3501	482205024702	1/8W 4.7K [MB]
R355, 356	ERDS2TJ333	1/4W 33K	C14, 15	ECEAOJKA470B	6.3V 47U	R3502	482205110104	1/8W 100K [MB]
R401	ERDS2TJ104	1/4W 100K	C16	ECEA1EU101	25V 100U	R3505	482205110123	1/4W 12K [MB]
R411, 412	ERDS2TJ472	1/4W 4.7K	C17, 18	ECEA1HU101	50V 100U	R3506	482205110101	1/8W 100 [MB]
R431, 432	ERDS2TJ223	1/4W 22K	C19	ECEA1CKA101B	16V 100U	R3507	482205120222	1/8W 2.2K [MB]
R433	ERDS2TJ104	1/4W 100K	C51	ECEA1AKA220B	10V 22U	R3508	482205110243	1/4W 24K [MB]
R434	ERDS2TJ224T	1/4W 220K	C201, 202	ECBT1C103NS5	16V 0.01U	R3509	482205110562	1/8W 5.6K [MB]
R435	ERDS2TJ104	1/4W 100K	C301	ECBT1C103NS5	16V 0.01U	R3510	482205110103	1/8W 10K [MB]
R436	ERDS2TJ224T	1/4W 220K	C302	ECBT1H270J5	50V 27P	R3521	482205110221	1/8W 220 [MB]
R437, 438	ERDS2TJ223	1/4W 22K	C303, 304	ECFRIE104ZF5	25V 0.1U	R3522	482205210229	1/3W 22 [MB]
R601	ERDS2TJ120T	1/4W 12	C305	ECBT1H102KB5	50V 1000P	R3523	482205210129	1/3W 12 [MB]
R801-804	ERDS2TJ330	1/4W 33	C306	ECFRIE223KB	25V 0.022U	R3524	482205110101	1/8W 100 [MB]
R805-808	ERDS2TJ433	1/4W 43K	C307	ECQV1H474J23	50V 0.47U	R3530	482205110473	1/4W 47K [MB]
R809-812	ERDS2TJ563	1/4W 56K	C308	ECBT1H102KB5	50V 1000P	R3531	482205110153	1/4W 15K [MB]
R815, 816	ERDS2TJ472	1/4W 4.7K	C309	ECFRIE104ZF5	25V 0.1U	R3533	482205110152	1/4W 5.1K [MB]
R817, 818	ERDS2TJ221	1/4W 220	C312	ECBT1C103NS5	16V 0.01U	R3534	482205110224	1/8W 220K [MB]
R819, 820	ERDS2TJ511	1/4W 510	C351	ECBT1H102KB5	50V 1000P	R3535	482205021203	3/5W 12K [MB]
R821, 822	ERDS2TJ473	1/4W 47K	C401	ECFRIE104ZF5	25V 0.1U	R3540	482205024708	3/5W 4.7 [MB]
R823, 824	ERDS2TJ331	1/4W 330	C402	ECEAOJKA470B	6.3V 47U	R3541	482205110682	1/4W 6.8K [MB]
R825, 826	ERDS2TJ102	1/4W 1K	C404	ECFRIE104ZF5	25V 0.1U	R3542	482205110829	1/8W 82 [MB]
R831, 832	ERDS2TJ470	1/4W 47	C601, 602	ECBT1H102KB5	50V 1000P	R3543	482205110682	1/8W 6.8K [MB]
R833	ERDS2TJ472	1/4W 4.7K	C801-804	ECQV1H683J23	50V 0.068U	R3550	482205110182	1/4W 1.8K [MB]
R834	ERDS2TJ102	1/4W 1K	C805-808	ECBT1H121KB5	50V 120P	R3555	482205110183	1/4W 18K [MB]
			C811, 812	ECQV1H683J23	50V 0.068U	R3560	482211191494	1/8W 11K [MB]
			C815, 816	ECBT1H102KB5	50V 1000P			

Ref. No.	Part No.	Values & Remarks	Ref. No.	Part No.	Values & Remarks
R3561	482205110154	1/4W 150K [MB]	C2563	482212233496	63V 0.1U [MB]
R3562	482205021204	3/5W 120K [MB]	C2625	482212231765	50V 100P [MB]
R3563	482205110563	1/8W 56K [MB]			
R3564	482211191495	1/8W 160K [MB]			
R3565	482205210279	1/3W 27 [MB]			
R3566	482205110229	1/8W 22 [MB]			
R3567	482205028203	1/8W 82K [MB]			
R3568	482205110474	1/4W 470K [MB]			
		CHIP JUMPER(S)			
R3801	482205110008	JUMPER [MB]			
R3802	482205110008	JUMPER [MB]			
		CAPACITORS			
C2501	482212232863	50V 0.022U [MB]			
C2502	482212440433	25V 47U [MB]			
C2503	482212232863	50V 0.022U [MB]			
C2504	482212231727	63V 470P [MB]			
C2505	482212440433	25V 47U [MB]			
C2506	482212233496	63V 0.1U [MB]			
C2507	482212231644	63V 2200P [MB]			
C2508	532212142491	100V 0.047U [MB]			
C2509	482212231772	50V 47P [MB]			
C2510	482212232442	50V 0.01U [MB]			
C2511	482212231746	50V 1000P [MB]			
C2513	482212143375	63V 0.22U [MB]			
C2514	482212151252	63V 0.47U [MB]			
C2515	482212231746	50V 1000P [MB]			
C2520	482212231965	63V 220P [MB]			
C2521	482212422027	25V 47U [MB]			
C2530	482212151321	63V 8200P [MB]			
C2531	482212151321	63V 8200P [MB]			
C2532	482212440272	16V 33U [MB]			
C2534	532212142661	63V 0.33U [MB]			
C2535	482212231981	50V 0.033U [MB]			
C2536	482212231981	50V 0.033U [MB]			
C2537	482212143375	63V 0.22U [MB]			
C2538	482212143375	63V 0.22U [MB]			
C2540	482212441583	50V 0.68U [MB]			
C2541	482212232863	50V 0.022U [MB]			
C2542	482212232863	50V 0.022U [MB]			
C2544	482212440196	16V 220U [MB]			
C2545	482212233496	63V 0.1U [MB]			
C2546	482212233496	63V 0.1U [MB]			
C2547	482212232863	50V 0.022U [MB]			
C2552	482212143526	100V 0.047U [MB]			
C2560	482212231784	50V 4700P [MB]			
C2561	482212151252	63V 0.47U [MB]			
C2562	532212142661	63V 0.33U [MB]			

■ PACKING

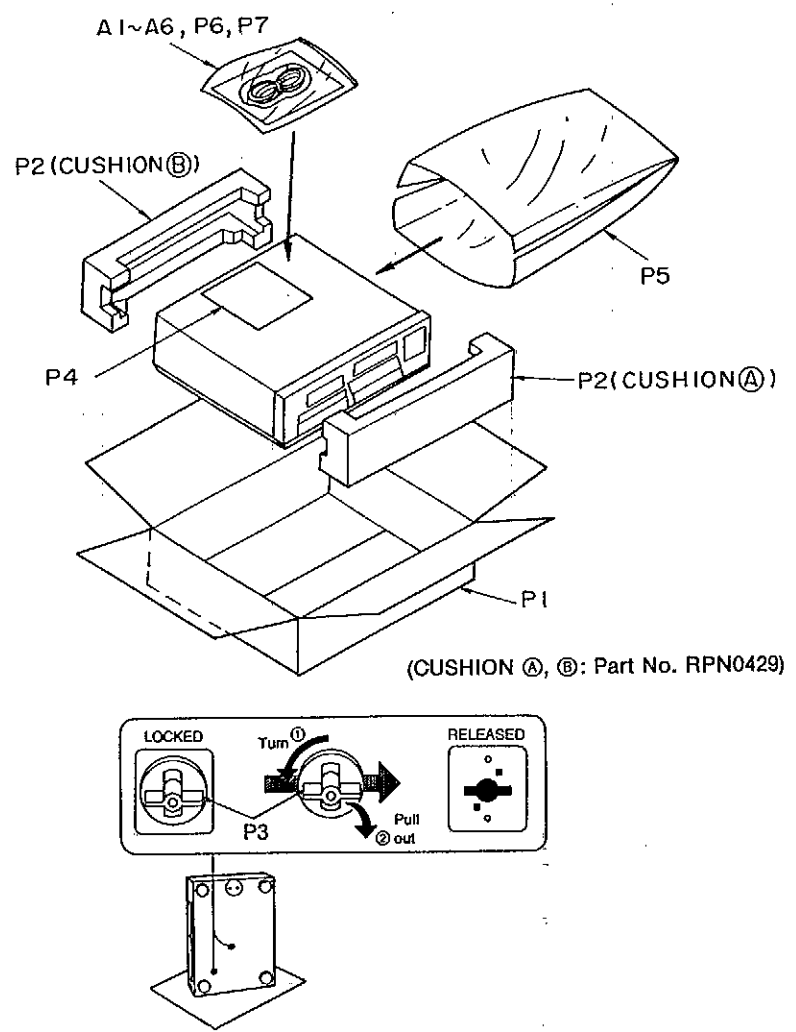

SL-PG520A Operation Sequence Check Sheet

Play Operation Sequence

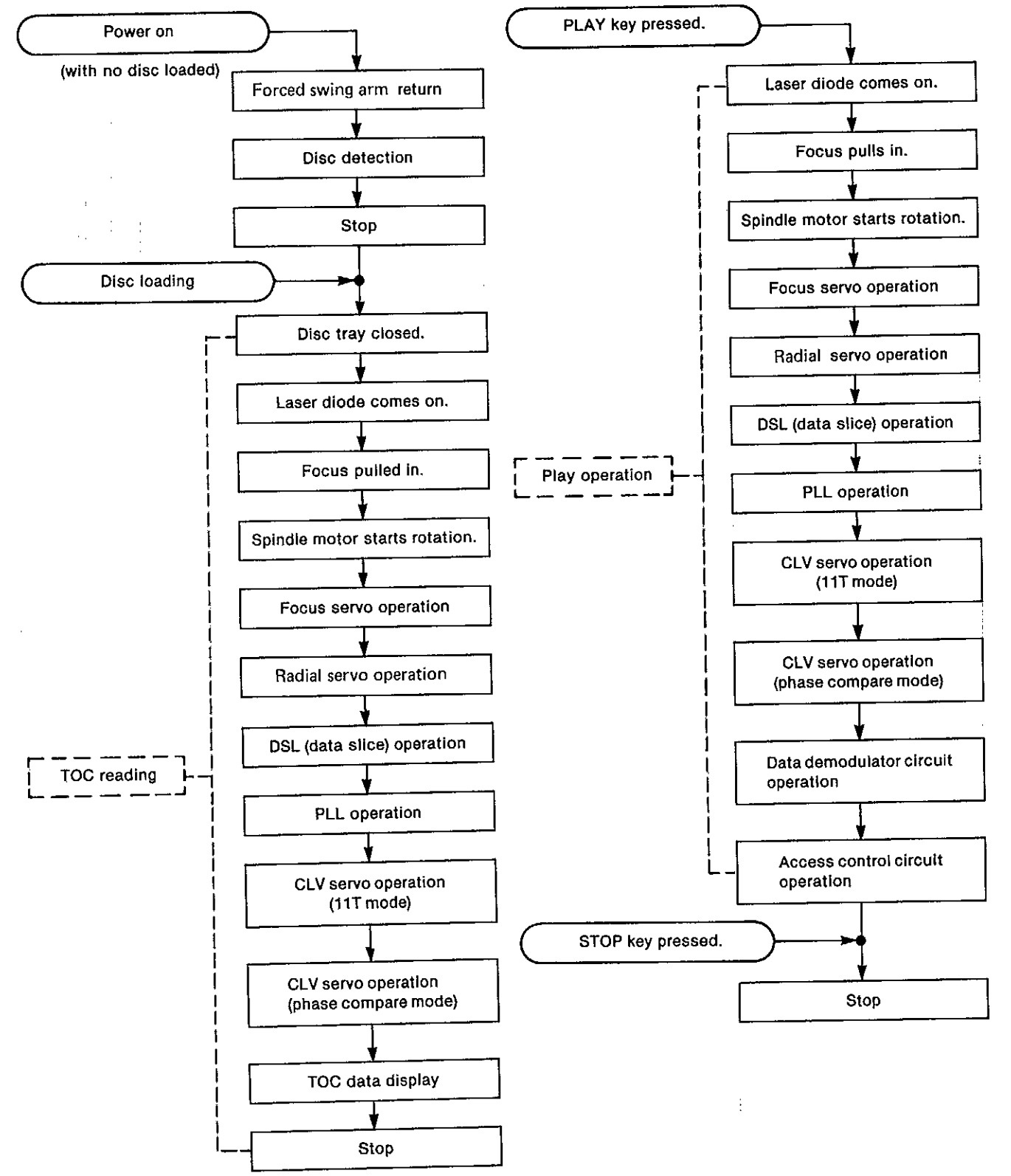

(Operation Sequence Just After Power On)

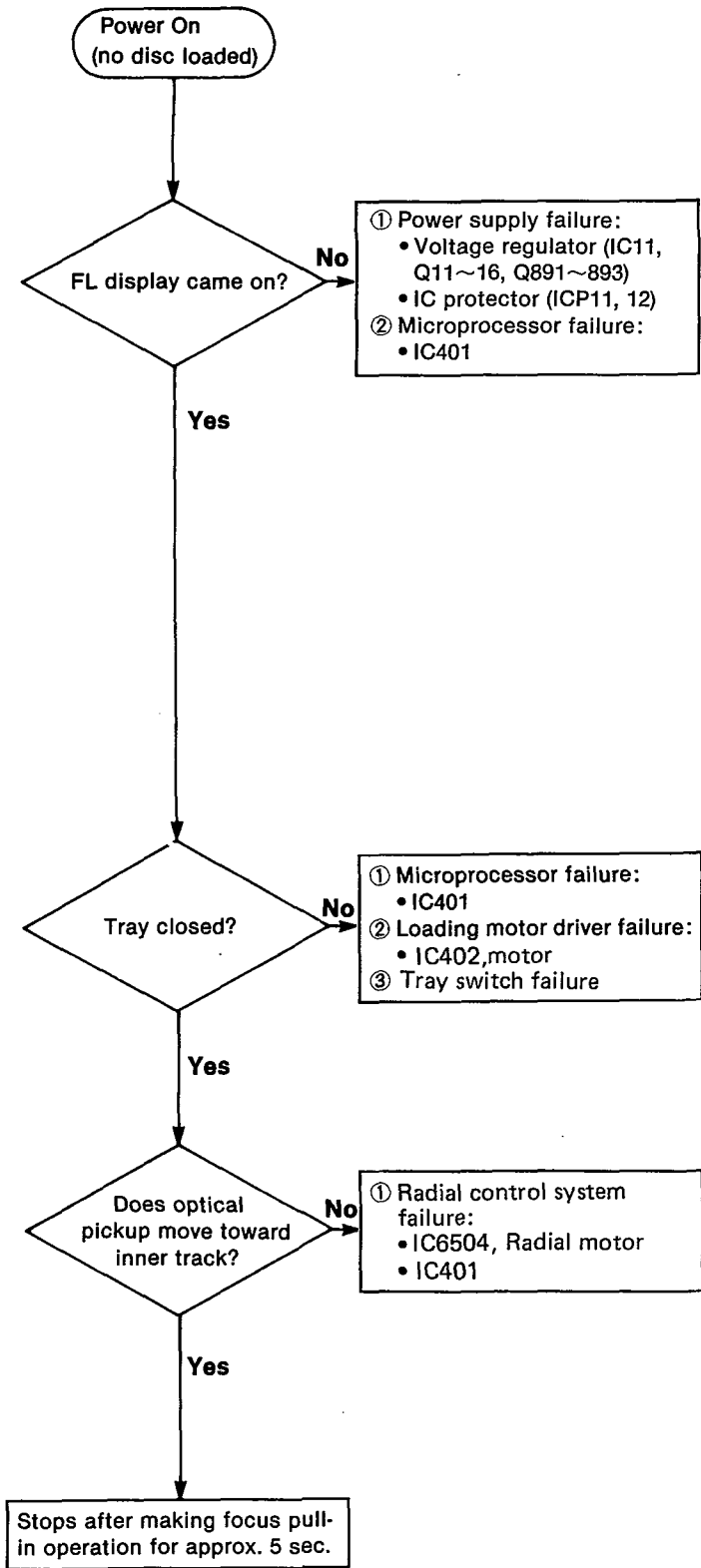

(TOC Read Operation-PLAY Operation)

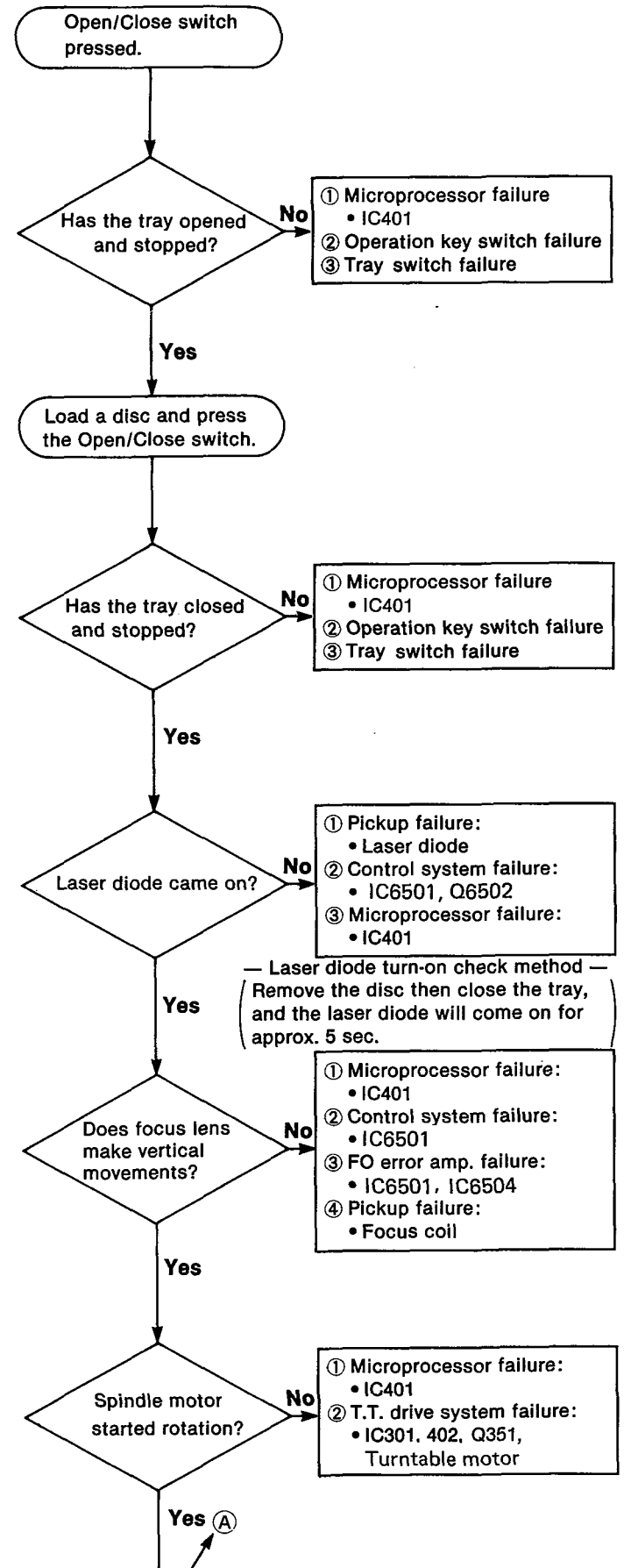

891

