

10/100 BASE FILTER WITH DUAL USB 2.0 CONNECTOR

Model NO.: RJLU-029TA1

CROSS REFERECE:P35-152-11Z9

Feature:

RoHS Compliant

- ⊙ Fully shielded magnetics protect data from internally generated digital noise
- ⊙ Reduces the overall length of the signal path for improved common mode performance
- ⊙ Implements full common mode termination scheme with used and unused twisted pairs
- ⊙ Meets IEEE802.3 Baseline Wander Compensation specification
- ⊙ Integrates high voltage capacitor to chassis ground
- ⊙ Supports all major transceivers with matched turns ration and complete integration of specified termination
- ⊙ Design for 100base-tx transmission over UTP-5 cable
- ⊙ Operating TEMP. range: -40°C to +85°C
- ⊙ Storage TEMP. range: -55°C to + 125°C
- ⊙ Primary OCL inductance: 350μH MIN. at 100KHz/0.1Vrms with 8mA DC bias
- ⊙ With the LED lamp

Typical Performance Characteristics@ 25°C

Insertion Loss (dB MAX)	Return Loss (dB Min @100±15Ω)				Differential to Common Mode Rejection (dB MIN)	Cross talk (dB MIN)					CMRR (dB MIN)	Isolation Voltage (Vrms min)
	MHz	MHz				MHz	MHz					
1~100	1~30	40	50	60~80	1~100	20	40	60	80	100	1~100	1500
-1.0	-16	-14	-12	-10	-33	-47	-40	-37	-35	-33	-30	

Schematic : Design on MDI Interface Circuitry

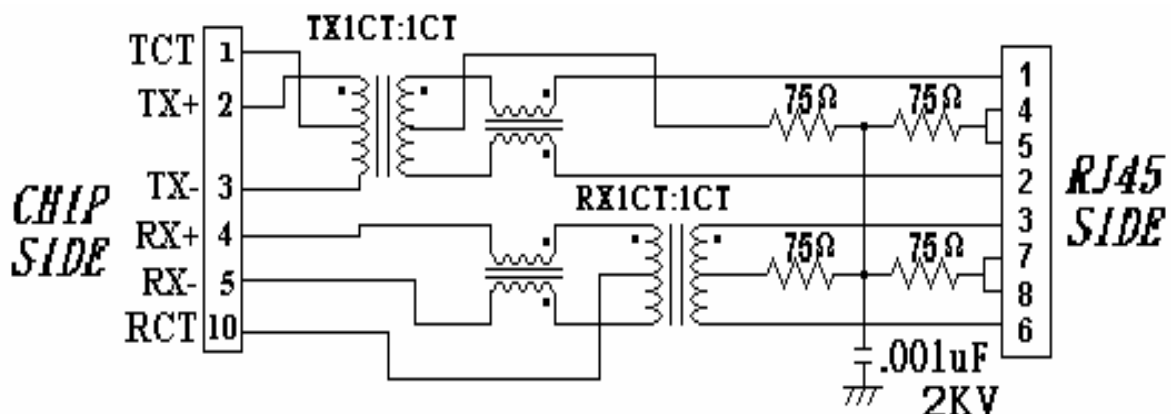



NUMBER:RD-RJ-RJLU-029TA1
DATE :2005/09/07 -I (REV:A1)

Model NO.: RJLU-029TA1

Ordering Information

R J L U - 0 2 9 T A 1	
R J 4 5	Series N O .
W i t h L E D	w i t h U S B

Requirements :

1. Design and Construction

Product shall be of design, construction and physical dimensions specified on applicable product drawing.

2. Materials and Finish

A. Contact:

RJ Contact : Phosphor Bronze, Thickness=0.30mm

Finish : (a) Contact Area : 6 μ "min. Gold over 50 μ "min. Nickel

RJ Joint Contact : Brass, Thickness=0.40mm

Finish : 80 μ "min. Sn over 50 μ "min. Nickel

USB Contact :Phosphor Bronze, Thickness=0.25mm

Finish : (a) Contact Area : 30 μ "min. Gold over 50 μ "min. Nickel

LED Joint Contact : Brass, Thickness=0.30mm

Finish : 80 μ "min. Sn over 50 μ "min. Nickel

B. Plastic Part :

(1) Set Housing : Thermoplastic, PBT, Black

UL FILE NO. : E107536

Manufacturer : SHIKONG SYNTHETIC FIBERS CORP.

Grade : E202G30BK

Flame Class : UL 94V-0



NUMBER:RD-RJ-RJLU-029TA1
DATE :2005/09/07 -I (REV:A1)

Model NO.: RJLU-029TA1

- (2) Insert : Thermoplastic, PBT, Black
UL FILE NO. : E107536
Manufacturer : SHIKONG SYNTHETIC FIBERS CORP.
Grade : E202G30BK
Flame Class : UL 94V-0
- (3) Spacer : Thermoplastic, PBT, Black
UL FILE NO. : E107536
Manufacturer : SHIKONG SYNTHETIC FIBERS CORP.
Grade : E202G30BK
Flame Class : UL 94V-0
- (4) USB Housing : Thermoplastic, PBT, Black
UL FILE NO. : E107536
Manufacturer : SHIKONG SYNTHETIC FIBERS CORP.
Grade : E202G30BK
Flame Class : UL 94V-0

C. Shield Material :

Cartridge $t=0.25\text{mm}$
 $10\mu\text{''}-20\mu\text{''}$ Thick Nickel over Brass

D. LED Lamp

- (a) Lens Color : Transparent with color
- (b) Emitted Color : Green & Yellow & Orange
- (c) View Angle : 65°
- (d) Wave Length : Green 565nm ; Yellow 585nm; Orange 605nm
- (e) Recommended operation current (IF) : 20 mA

3. Ratings

- (1) Voltage rating : 125 VAC
- (2) Current rating : 1.5A

Durability :

- (1) 1000 cycles with no function damage for RJ-45 . Abnormalities shall be present after the test.
- (2) Low Level Contact Resistance : $\Delta R=30\text{m}\Omega$ maximum (final)
- (3) The sample should be mounted in the tester and fully mated and unmated 500 times per hour at the rate of 25mm/min. EIA-364-09C.



NUMBER:RD-RJ-RJLU-029TA1
DATE :2005/09/07 -I (REV:A1)

Model NO.: RJLU-029TA1

1. Unit weight :20.6 grams
2. package : 50 pcs / tray / 1.044 kgms
3. Carton : 400 pcs / 8 layers of tray
4. Gross weight : 8.964 kgms

Package drawing:

