



AL250/251 Data Sheets

Contents

1.0 Features	3
2.0 Applications	3
3.0 General Description	4
4.0 Pinout Diagrams	5
5.0 Pin Definition and Description	6
6.0 Functional Description	8
6.1 Digital Input/Output Data Formats	8
6.2 Default Resolution	9
6.3 Video Timing	9
6.4 Border/Border Color	13
6.5 OSD Interface	14
6.6 External Overlay	15
6.7 Look-up Table (LUT)	16
6.8 I²C Programming	16
6.9 Video Decoding	18
7.0 Electrical Characteristics	20
7.1 Recommended Operating Conditions	20
7.2 Characteristics	20
8.0 AL250/251 Register Definition	22
8.1 Register Description	23
9.0 Board Design and Layout Considerations	29
9.1 Grounding	29
9.2 Power Planes and Power Supply Decoupling	29

AL250/251 Video Scan Doubler

1.0 Features

- Convert interlaced TV signal (NTSC/PAL) into non-interlaced RGB format for CRT monitors or LCD panels
- Highly integrated design with built-in DAC, SRAM, OSD and LUT
- Built-in on-screen-display with programmable bitmap
- Interpolated scan doubling with no tearing or jagged edge artifacts
- Reduced interlace flicker
- Auto NTSC/PAL detect
- Digital video input of square pixel, ITU-RBT 601 (CCIR 601), or user-defined format
- Analog/digital non-interlaced RGB (VGA) signal output (Scan Doubled or Deinterlaced)
- I²C programming interface
- Power-down control via I²C
- Internal RGB video lookup table (LUT) to provide gamma correction and special effects
- Overlay support for title making and complex on-screen display
- Self-initialization without software (Plug & Play)
- 3.3 or 5 volt support
- 16-bit digital RGB/YUV output (AL251 only)

2.0 Applications

- TV-ready Multimedia Computer Monitor
- TV to PC Video Scan Converter Box
- Progressive Scan TV
- Video Game Station
- DVD Player
- LCD TV Monitor

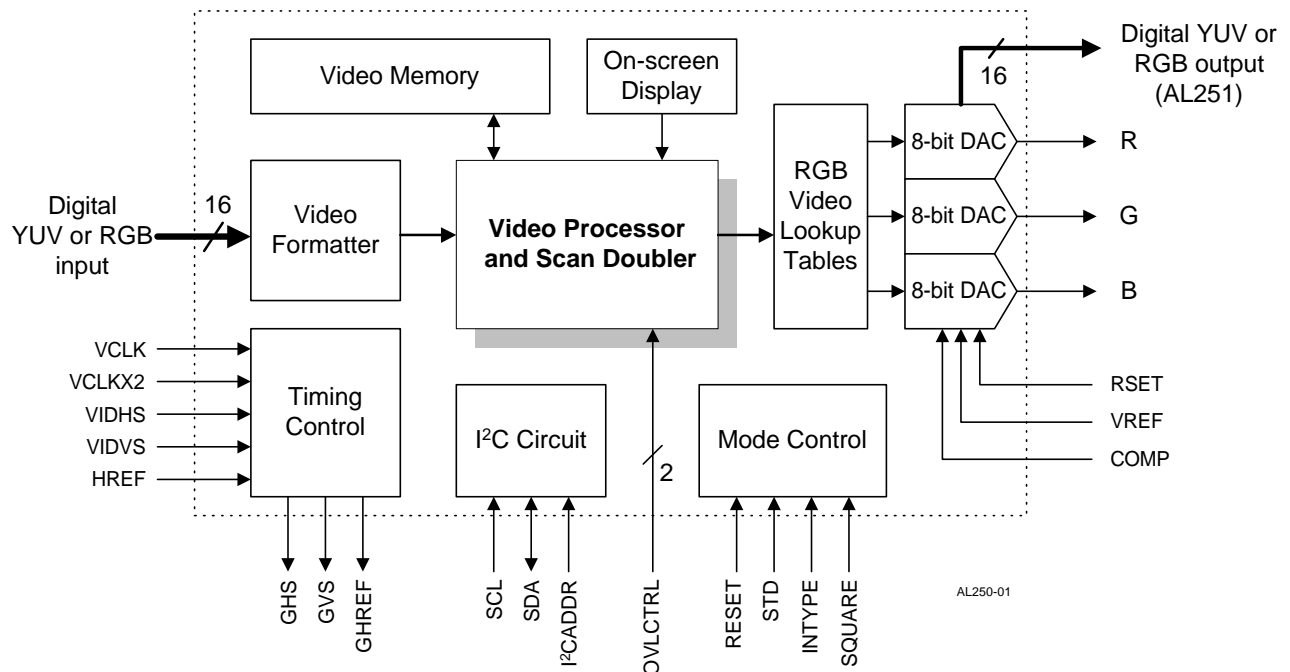

3.0 General Description

The AL250/251 Video Scan Doubler (De-Interlacer) is a video conversion chip for consumer video and multimedia applications. It converts interlaced NTSC or PAL, ITU-RBT 601 (CCIR 601) or square pixel, YUV422 or RGB565 digital signals into computer monitor RGB signals for direct connection to a computer monitor or progressive scan TV.

By using I²C interface control, the AL250/251 can also be programmed to co-ordinate with various input resolutions, adjust screen positioning and crop video noise from around the original input video boundary.

The internal RGB video lookup tables (LUT), which are controlled via I²C interface, can provide gamma correction for calibrating the color accuracy of different types of CRT's and improving the contrast level to display more vivid pictures.

A built-in on-screen-display (OSD) provides programmable bitmap RAM for custom design icons and on-screen control panels.

Overlay function is supported to create titling or on-screen-display menus for video adjustment.

The AL251 provides all the features of the AL250. Additionally, it has digital output in YUV422 or RGB565 format, and can convert NTSC video for VGA LCD panels.

The AverLogic proprietary digital signal processing technology creates a highly stable video image without tearing effects or jagged edges. The output picture is smoother and has less flicker than the original input signal/picture.

4.0 Pinout Diagrams

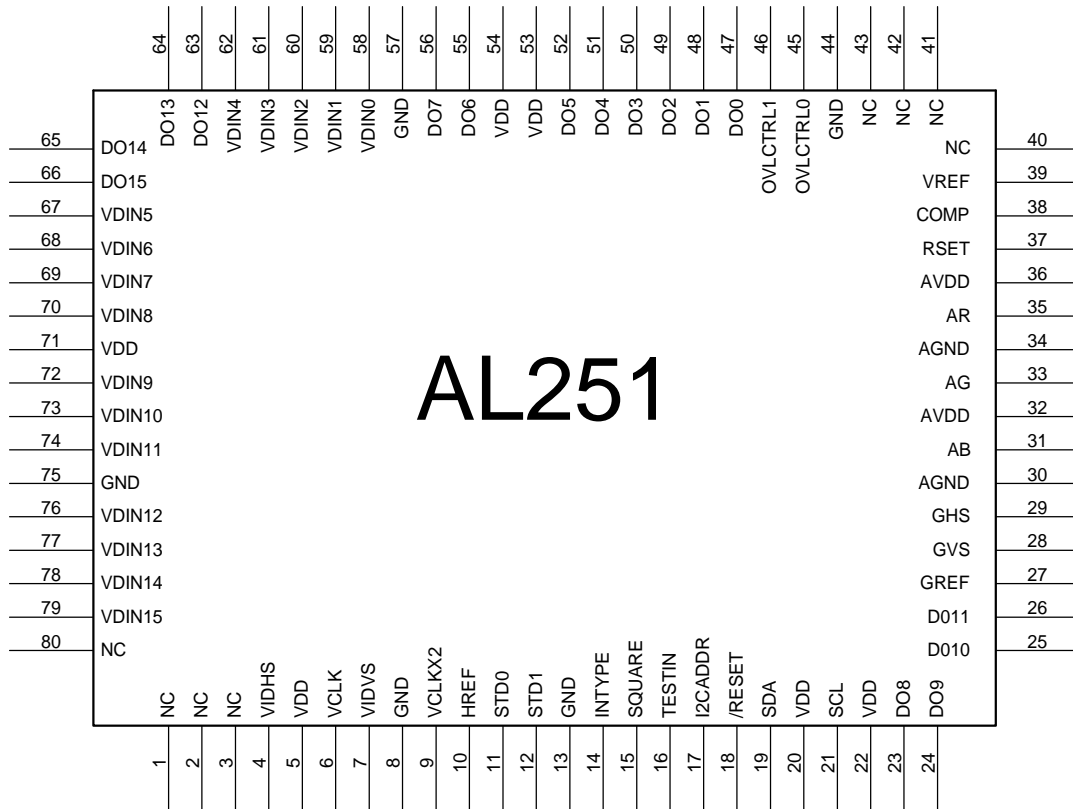
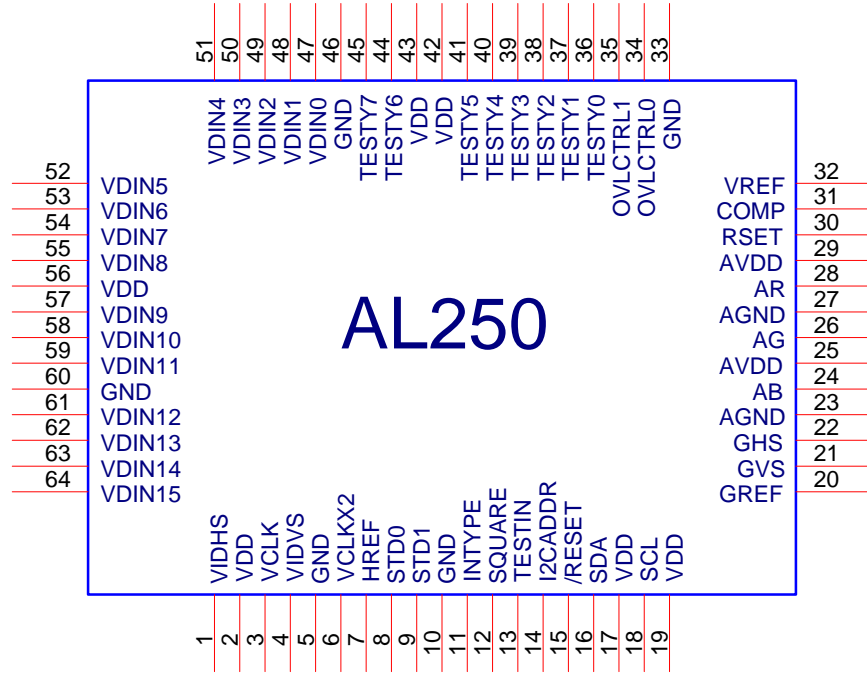

AL251-01 pinout diagram

5.0 Pin Definition and Description

Symbol	Type	250 Pin #	251 Pin #	Description
Video Interface				
VDIN (15 to 0)	in (CMOS)	64-61, 59-57, 55-52, 51-47	79-76, 74-72, 70-67, 62-58	Digital video data input. Please refer to the input data format table for details
VCLK	in (CMOS)	3	6	Video clock input
VCLKX2	in (CMOS)	6	9	2 times of video clock input
VIDHS	in (CMOS)	1	4	Horizontal sync. input signal
VIDVS	in (CMOS)	4	7	Vertical sync. input signal
HREF	in (CMOS)	7	10	Horizontal reference input signal; this signal is used to indicate data on the digital YUV bus. The positive slope marks the beginning of a new active line.
Graphic Interface				
RSET	In (100 ohm)	30	37	Full Scale Current Adjust; 100 ohm pull-down
VREF	in (1.235V)	32	39	Voltage Reference Input
COMP	out (0.1 μ F)	31	38	Compensation pin; 0.1 μ F pull-up
AR	out (0.7V)	28	35	VGA analog red output
AG	out (0.7V)	26	33	VGA analog green output
AB	out (0.7V)	24	31	VGA analog blue output
DO (15 to 0)	out (CMOS)	N/A	66-63, 26-23, 56-55, 52-47	Digital YUV422 or RGB565 output, selected by register 08h <7>
GHS	out (TTL)	22	29	VGA horizontal sync. output signal
GVS	out (TTL)	21	28	VGA vertical sync. output signal
GHREF	out (CMOS)	20	27	VGA horizontal reference output signal; it can be used to indicate blanking interval.
Reset & Mode Select				
/RESET	in (CMOSd)	15	18	Reset input; active low
STD (1 to 0)	in (CMOSd)	9, 8	12, 11	Video Input Standard select 00: NTSC input 01: PAL input

				10: Automatic standard detection 11: Reserved for testing
INTYPE	in (CMOSd)	11	14	Input video data format select 0: 422 YUV (16-bit) 1: 565 RGB (16-bit)
SQUARE	in (CMOSd)	12	15	Square pixel/YUV (CCIR-601) input select 0: YUV (CCIR-601) 1: Square pixel
TESTIN	in (CMOSd)	13	16	Test input pin, to be pulled high for normal applications.
I2C & overlay Interface				
SCL	in (CMOSSu)	18	21	I ² C-bus serial clock input
SDA	in/out (CMOSSu)	16	19	I ² C -bus serial data input/output
I2CADDR	in (CMOSd)	14	17	I ² C -bus slave address select 0: write address = 58, read address = 59 1: write address = 5C, read address = 5D
OVLCTRL (1 to 0)	in (CMOSd)	35, 34	46, 45	Overlay control 00: No overlay 01: Overlay color #1 10: Overlay color #2 11: Overlay color #3 Overlay colors can be programmed by software
Test pins				
TESTY (7 to 0)	out (CMOS)	45-44, 41-36	N/A	Test output pins, for factory test only
Power & Ground Pins				
VDD	power	2, 17, 19, 42, 43, 56	5, 20, 22, 53, 54, 71	Digital power pins. Connected to +5V power
GND	power	5, 10, 33, 46, 60	8, 13, 44, 57, 75	Digital ground pins
AVDD	power	25, 29	32, 36	Analog power pins. Connected to +5V power
AGND	power	23, 27	30, 34	Analog ground pins

Notes:

CMOSd : CMOS with internal pull-down

CMOSsu : CMOS with Schmitt trigger and internal pull-up

6.0 Functional Description

6.1 Digital Input/Output Data Formats

The digital video data formats that the AL250/251 accepts are YUV422 and RGB565. The pin definition and the RGB 888 to 565 mapping is as follows:

Video Data Signal	Pin Number		YUV 422	RGB 888→565
	AL250	AL251		
VDIN15	64	79	Y7	R7
VDIN14	63	78	Y6	R6
VDIN13	62	77	Y5	R5
VDIN12	61	76	Y4	R4
VDIN11	59	74	Y3	R3
VDIN10	58	73	Y2	G7
VDIN9	57	72	Y1	G6
VDIN8	55	70	Y0	G5
VDIN7	54	69	U7, V7	G4
VDIN6	53	68	U6, V6	G3
VDIN5	52	67	U5, V5	G2
VDIN4	51	62	U4, V4	B7
VDIN3	50	61	U3, V3	B6
VDIN2	49	60	U2, V2	B5
VDIN1	48	59	U1, V1	B4
VDIN0	47	58	U0, V0	B3
Pixel clock	-	-	VCLK	VCLK
INTYPE select			INTYPE = 0	INTYPE = 1

To select YUV422 or RGB565 as the input format, program the Board Configuration Register #02h, or set the hardware pin “INTYPE” (AL250 pin#11, AL251 pin#14).

The AL251 provides digital output in RGB565 or YUV422 format. The pin definition and the RGB565 to 888 mapping is as follows:

Video Data Signal	AL251 Pin #	YUV 422	RGB 565→888
DO7	56	Y7	R7
DO6	55	Y6	R6
DO5	52	Y5	R5

DO4	51	Y4	R4
DO3	50	Y3	R3
DO2	49	Y2	G7
DO1	48	Y1	G6
DO0	47	Y0	G5
DO15	66	U7, V7	G4
DO14	65	U6, V6	G3
DO13	64	U5, V5	G2
DO12	63	U4, V4	B7
DO11	26	U3, V3	B6
DO10	25	U2, V2	B5
DO9	24	U1, V1	B4
DO8	23	U0, V0	B3
OutFormat select	-	1	0

To select YUV422 or RGB565 as the output format, program the Control Register #08h<7>, i.e., OutFormat.

6.2 Default Resolution

The resolution of the AL250/251 applications depends on the input video source, e.g., the digital video decoder. The typical resolution of the video decoder that the AL250/251 supports without software, and the VCLK frequency provided by the decoder to the AL250/251 is as follows:

	Square Pixel		CCIR 601	
	NTSC	PAL	NTSC	PAL
Pixel Total	780 x 525	944 x 625	858 x 525	864 x 625
Pixel Active	640 x 480	768 x 576	720 x 480	720 x 576
VCLKx2 (MHz)	24.545454	29.5	27	27
VCLK (MHz)	12.272727	14.75	13.5	13.5

The AL250/251 can process up to 768 active pixels per line and 1024 lines per frame.

6.3 Video Timing

The AL250/251 registers 20h~29h and 2Bh~2Eh are used to control the video timing. All increments are either by 8 pixels per line or by 4 lines per frame. All values (times 8 or 4) are relative to the input video source H-sync or V-sync. These registers need to be programmed if the input video resolution is different from the default resolution supported.

The H-sync Start and End (registers 22h and 23h) define the output horizontal sync period relative to the input H-sync leading edge.

The Horizontal Blank Start and End (registers 2Bh and 2Ch) define the output H-sync blanking period.

The Horizontal Capture Start and End (registers 20h and 21h) define the active pixels in each line relative to the input video H-sync. These registers can also be used for adjusting the position of the output picture.

The Horizontal Total High and Low (registers 24h and 29h) define the total number of pixels per line. The AL250/251 can detect the H-total automatically when the input data is of the typical resolution mentioned in the Default Resolution section.

The V-sync Start and End (registers 27h and 28h) define the output V-sync period relative to the input V-sync start.

The Vertical Blank Start and End (registers 2Dh and 2Eh) define the output V-sync blanking period.

The Vertical Capture Start and End (registers 25h and 26h) define the active lines.

The total number of lines per frame (Vertical Total) is detected by the AL250/251 automatically.

To take advantage of the auto detection of the AL250/251, set the bit 3 of the Control register #08h (Softtime) as 0. If a user-defined input format is used, then disable the hardware default by setting this bit as 1, and write all of the parameters to the corresponding registers to define the format. The sample code the AL250EVB provides disables the hardware settings.

The following typical parameters (as well as hardware default values) are for reference:

Mode	Square NTSC	Square PAL	CCIR NTSC	CCIR PAL
H(Horizontal) total	780	944	858	864
V(Vertical) total	525	625	525	625
HDE Start	120	160	72	80
HDE End	736	896	752	760
H-sync Start	776	0	792	808
H-sync End	56	72	856	16
VDE Start	48	60	48	60
VDE End	500	604	500	604
V-sync Start	4	4	4	4
V-sync End	8	8	8	8

Reg.#20h HDE Start	0Fh	14h	09h	0Ah
Reg.#21h HDE End	5Ch	70h	5Eh	5Fh
Reg.#22h H-sync Start	61h	00h	63h	65h
Reg.#23h H-sync End	07h	09h	6Bh	02h
Reg.#24h HTOTAL10_3	61h	76h	6Bh	6Ch
Reg.#29h HTOTAL2_1	02h	00h	01h	00h
Reg.#25h VDE Start	0Ch	0Fh	0Ch	0Fh
Reg.#26h VDE End	7Dh	97h	7Dh	97h
Reg.#27h V-sync Start	01h	01h	01h	01h
Reg.#28h V-sync End	02h	02h	02h	02h
Reg.#2Bh H-blank Start	5Fh	73h	61h	62h
Reg.#2Ch H-blank End	0Ch	11h	06h	07h
Reg.#2Dh V-blank Start	7Fh	99h	7Fh	99h
Reg.#2Eh V-blank End	0Ah	0Dh	0Ah	0Dh

The output timing/format is as follows:

	Square NTSC	Square PAL	CCIR NTSC	CCIR PAL
Resolution	640x480/616x452	768x576/736x544	720x480/680x452	720x576/680x544
Pixel rate	24.5454 MHz	29.5 MHz	27.00 MHz	27.00 MHz
Interlace	No	No	No	No
Video	Analog-color	Analog-color	Analog-color	Analog-color
Sync on G	No	No	No	No
Video level	700mV/1V*	700mV/1V*	700mV/1V*	700mV/1V*
White level	700mV/1V*	700mV/1V*	700mV/1V*	700mV/1V*
Black level	0 IRE	0 IRE	0 IRE	0 IRE
H total	780	944	858	864
H display	616*	736*	680*	680*
H F-porch	40*	48*	40*	48*
H B-porch	64*	88*	74*	64*
HS width	60*	72*	64*	72*
H border	24*	24*	24*	24*
V total	525	625	525	625

V display	452*	544*	452*	544*
V F-porch	29*	25*	29*	25*
V B-porch	40*	52*	40*	52*
VS width	4*	4*	4*	4*
V border	8*	8*	8*	8*
HS output	ON(-)*	ON(-)*	ON(-)*	ON(-)*
VS output	ON(-)*	ON(-)*	ON(-)*	ON(-)*
Fh	31.4685 KHz	31.250 KHz	31.4685 KHz	31.250 KHz
Fv	59.94 Hz	50 Hz	59.94 Hz	50 Hz

Remark: Values with “*” are programmable (S/W) or adjustable (H/W).

The horizontal video timing diagram is as follows.

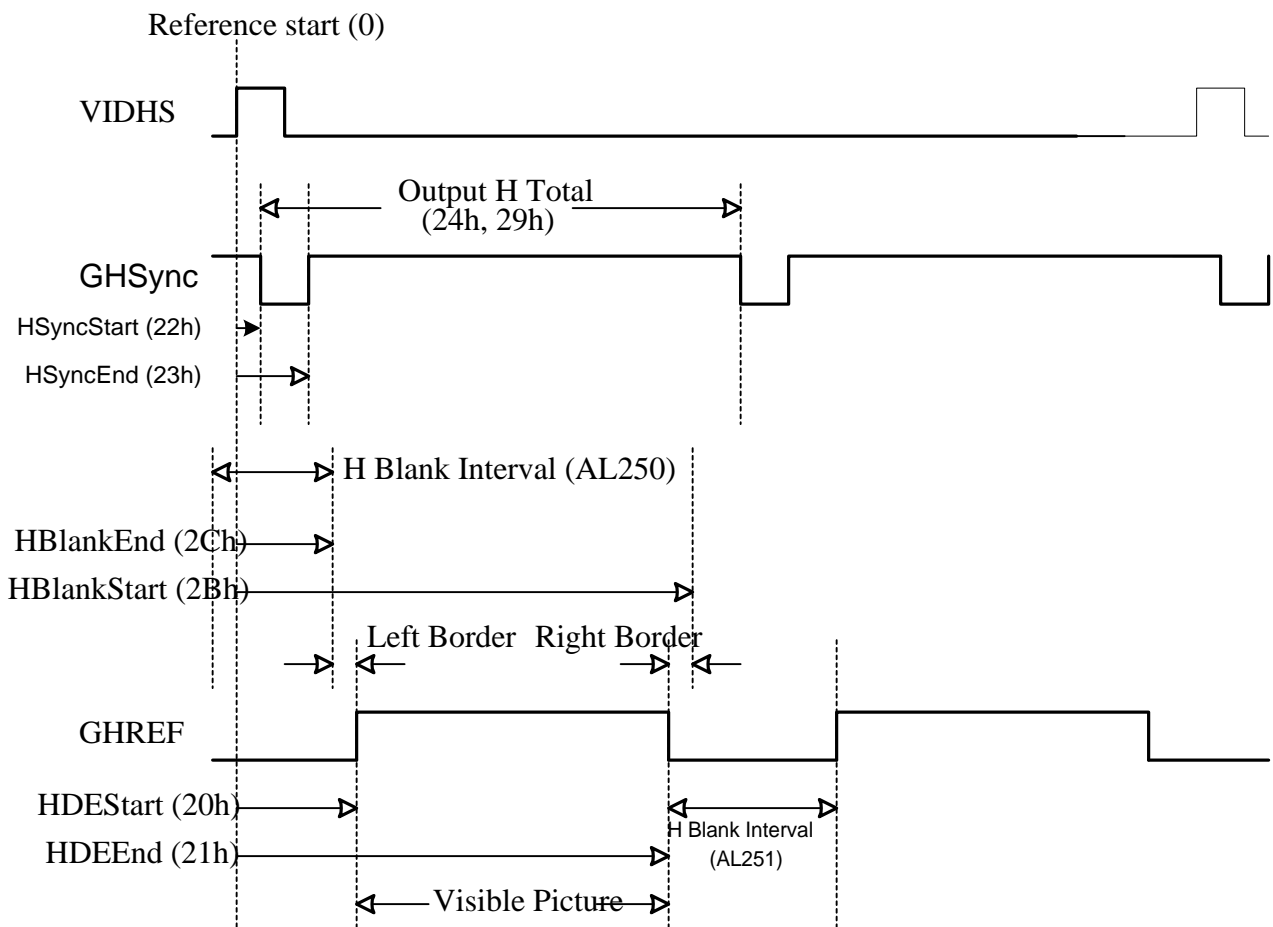

AL250-06 Horizontal timing diagram

The vertical video timing diagram is as follows.

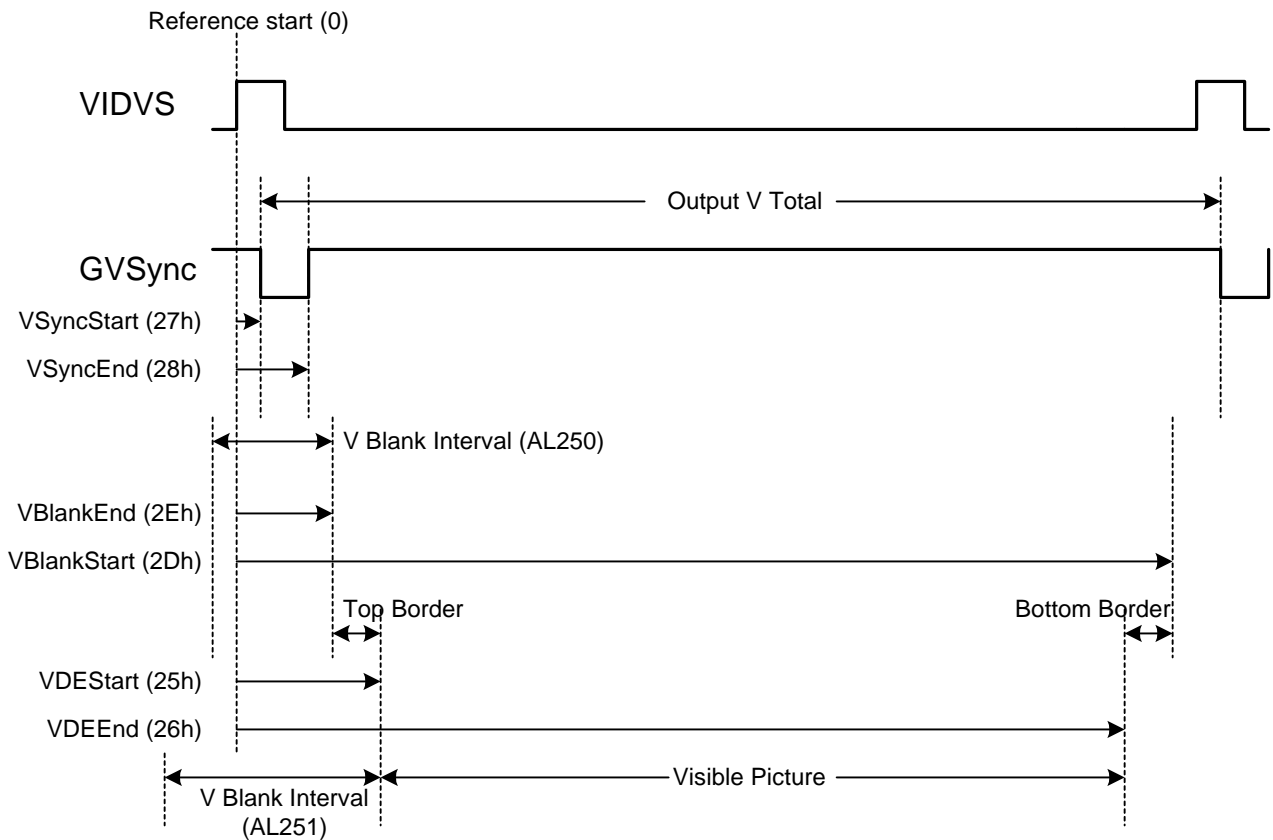

AL250-26 Vertical timing diagram

Details about the registers can be found in the Register Definition section.

6.4 Border/Border Color

The AL250/251 displays all the active pixels from the video source resulting in a larger viewable area on a monitor than on a regular TV. This is especially advantageous for digital video sources such as DVD. However, for some other video sources such as VCR, the unwanted and untrimmed border may appear. To solve this, the AL250/251 provides border control by cropping the video source. In addition, the cropped border can be filled with one color (24-bit), which is defined by registers 0Ch~0Eh.

Border/border color control applies to the AL250/251 analog output but not to the AL251 digital YUV/RGB output.

6.5 OSD Interface

The AL250/251 provides two ways to implement the on screen display. The internal way is to program the built-in on-screen display (OSD) bitmap, and the external way is to control the two overlay pins for showing on screen display or creating special effects onto each single pixel on screen. The AL250/251 provides 256 registers to implement the two internal bitmaps, which are programmable as 16x16 blocks (4x4 pixels each) and 48x16 blocks (8x8 pixels each) respectively.

To program the OSD, first use LUT/OSD Control register 10h to turn on bitmap 1 or bitmap 2. Then program the overlay colors 1, 2 and 3 through registers 15h~1Dh. Select the OSD index (0~255) through register 11h, then fill the data through register 13h. The two bits of each OSD block can be used to define no overlay color (transparent) or color 1, 2 or 3. Mesh color and mesh background can be enabled by programming register 2Fh. The position of the bitmaps can be defined by registers 1Eh, 1Fh, and 2Fh.

The data index of the bitmap 1 starts at bitmap address 192, and the lay-out is defined as follows:

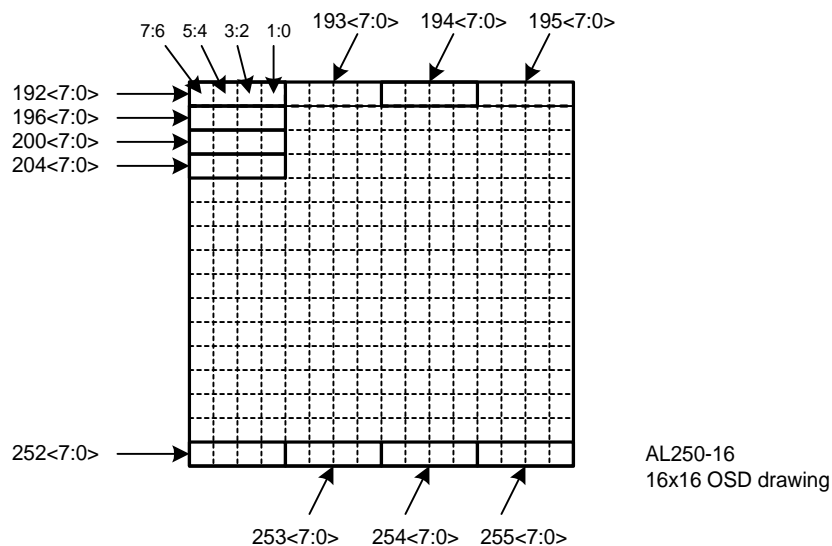

Each pixel is defined by 2 bits value (“00”, “01”, “10” and “11”).

Value “00” shows the current input video data.

Value “01”, “10” and “11” are index to overlay color 1~3 (defined in registers 15h ~ 1Dh).

The data index of bitmap 2 starts at bitmap address 0, and the lay-out is defined as follows:

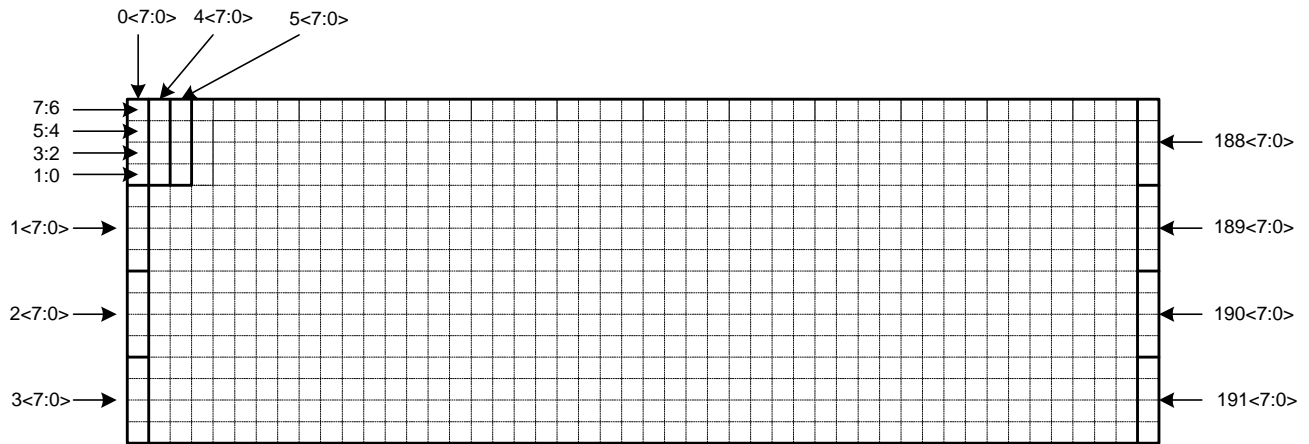

AL250-17 16x48 OSD drawing

Similar to bitmap 1, each pixel is defined by 2 bits value (“00”, “01”, “10” and “11”) with the same definition.

The horizontal positions of the bitmaps 1 & 2 are defined by registers 1Eh and 1Fh respectively. The vertical position of both is defined by register 2Fh.

For the external OSD, the overlay feature needs to be used and this will be explained in detail in the External Overlay section.

OSD control applies to the AL250/251 analog output and the AL251 digital RGB output, but not to the AL251 digital YUV output.

6.6 External Overlay

The AL250/251 provides two overlay pins (OVLCTRL1 and OVLCTRL0) for overlay control as well as some special effects. They can be pulled as 00 for no overlay, and 01, 10, 11 for different overlay colors or effects. The colors can be chosen from any one of 16M colors (defined by 24 bits RGB) by programming registers 15h~1Dh. The effects can be logic AND, OR, or XOR of the video source with any of the three overlay colors by programming register 14h. For instance, a negative film effect can be produced by XOR the original video source with white color. More details can be found in the Register Definition section.

Using the external overlay of the AL250/251 for caption display is possible if the OSD or FPGA chip chosen for displaying fonts of the decoded caption has the two overlay pins compatible with the AL250. If not, then the digital or analog output of the OSD can still be multiplexed with the output of the AL250/251 to show captions on the video display.

External overlay applies to the AL250/251 analog output and the AL251 digital RGB output, but not to the AL251 digital YUV output.

6.7 Look-up Table (LUT)

Because of the different characteristics of TV's and PC monitors, direct color space conversion from TV to PC may not show the same color that the human eye sees from the original video on the TV. The contrast may not be sufficient, and the hue may not be accurate, so to resolve these issues the AL250/251 has a gamma correction internal LUT implemented.

The AL250/251 provides 768 registers for implementing the LUT. The directly converted colors are sent to the LUT that then sends out the mapped, corrected colors. To program the LUT, first choose a color (R, G or B) from register 10h, select the LUT index (0~255) through register 11h, then fill the data (0~255) through register 13h. The input 8-bit R (or G or B) value is then converted to the corrected R (or G or B) value.

The user can program the LUT based on his/her own experiments on specific types of monitors. The typical input-output mapping curve is usually somewhat like the following:

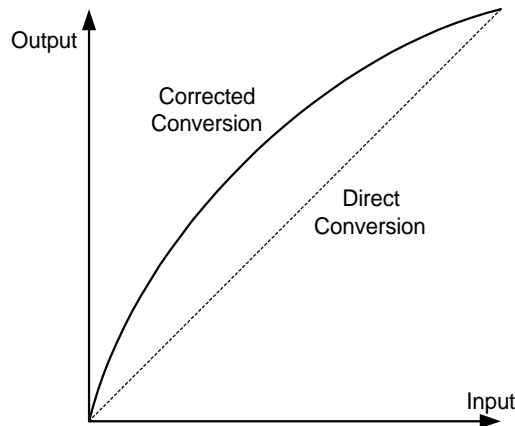

LUT control applies to the AL251/251 analog output but not to the AL251 digital YUV/RGB output.

6.8 I²C Programming

The AL250/251 I²C programming interface follows the Philips standard. The I²C interface consists of the SCL (clock) and SDA (data) signals. Data can be written to or read from the AL250/251. For both read and write, each byte is transferred MSB first, and the SDA data bit is valid when the SCL is pulled high.

The read/write command format is as follows:

Write: <S> <Write SA> <A> <Register Index> <A> <Data> <A> <P>

Read: <S> <Write SA> <A> <Register Index> <A> <S> <Read SA> <A> <Data> <NA> <P>

Following are the details:

<S>:

Start signal

SCL	SDA
High	High
High	Low

The Start signal is HIGH to LOW transition on the SDA line when SCL is HIGH.

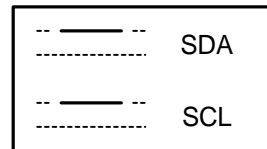

Data bit [1] or NA

<WRITE SA>:

Write Slave Address: 58h or 5Ch

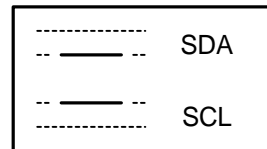

Data bit [0] or A

<READ SA>:

Read Slave Address: 59h or 5Dh

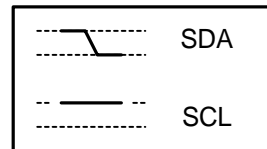

START bit [S]

<REGISTER INDEX>:

Value of the AL250/251 register index.

<A>:

Acknowledge stage

The acknowledge-related clock pulse is generated by the host (master). The host releases the SDA line (HIGH) for the AL250/251 (slave) to pull down the SDA line during the acknowledge clock pulse.

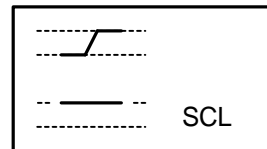

STOP bit [P]

<NA>:

Not Acknowledge stage

The acknowledge-related clock pulse is generated by the host (master). The host releases the SDA line (HIGH) during the acknowledge clock pulse, but the AL250/251 does not pull it down during this stage.

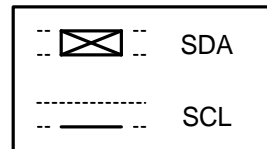

Not significant

AL250-15 I2C drawing

<DATA>:

Data byte write to or read from the register index.

In read operation, the host must release the SDA line (high) before the first clock pulse is transmitted to the AL250.

<P>:

Stop signal

SCL SDA

High Low

High High

The Stop signal is LOW to HIGH transition on the SDA line when SCL is HIGH.

Suppose data F0h is to be written to register 0Fh using write slave address 58h, the timing is as follows:

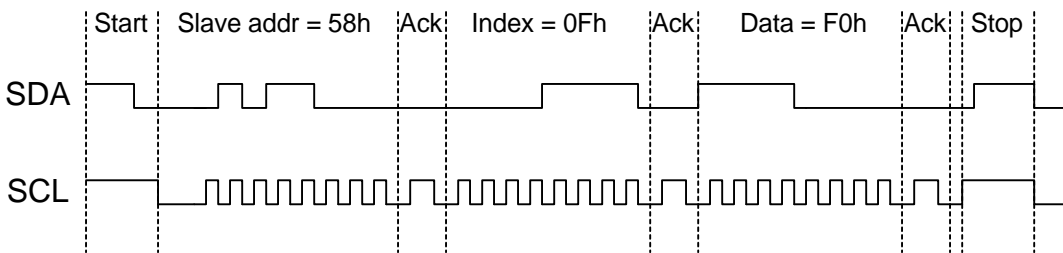

AL250-24 I2C Write timing

Suppose data is to be read from register 55h using read slave address 59h, the timing is as follows:

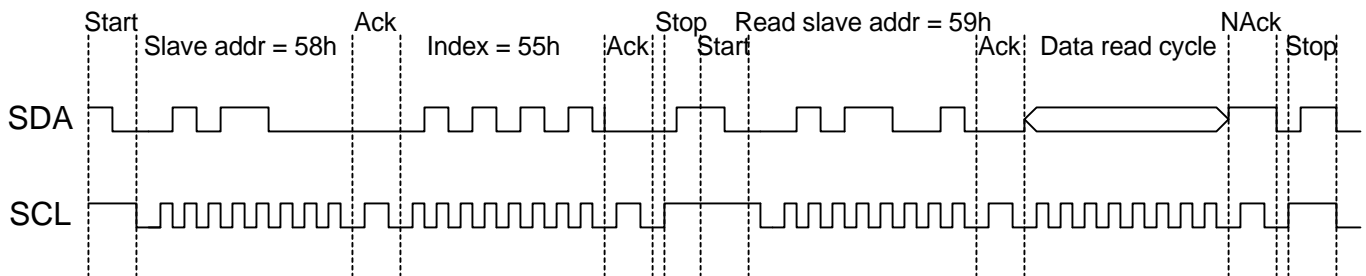

AL250-25 I2C Read timing

6.9 Video Decoding

A video decoder (video input processor) is needed with the AL250/251 for S-video or composite video processing. Please note that the AL250/251 works only with line-locked video decoders.

There are a number of video decoders available in the market; following is a selection chart. For detailed information, please consult with the decoder vendors or their distributors directly. The attached information is believed to be accurate but not guaranteed.

Decoder	Vendor	Line locked	NTSC/ PAL	RGB565	CCIR 601	Square Pixel	Closed Caption	Tele text
SAA 7110	Philips	V	V			V		
SAA 7111	Philips	V	V	V	V			
SAA 7112	Philips	V	V	V	V			
KS0127	Samsung	V	V	V	V	V	V	
VPC3211B	ITT	V	V		V			V

More information on the AL250/251 functionality can be found in the Register Definition section.

7.0 Electrical Characteristics

7.1 Recommended Operating Conditions

Parameter	Min	Max	Unit
VDD Supply Voltage	+3.0	+5.5	V
TAMB Ambient Operating Temperature	0	+70	°C

7.2 Characteristics

Parameter	Test Conditions	Min	Max	Unit	
I _{DD}	Supply current	55	110	mA	
P	Power consumption	180	600	mW	
V _{IH}	Hi-level input voltage	0.7VDD	VDD+0.5	V	
V _{IL}	Lo-level input voltage	-0.5	+0.8	V	
V _{OH}	Hi-level output voltage	2.4	VDD	V	
V _{OL}	Lo-level output voltage	-	0.5	V	
I _O	Output current, data	-0.5V < V _O < V _{DD} +0.5	-2	2	mA
	Output current, GHREF	-0.5V < V _O < V _{DD} +0.5	-4	4	mA
	Output current, GHS, GVS	-0.5V < V _O < V _{DD} +0.5	-12	12	mA
I _{LI}	Input leakage current	-	1	μA	
C _i	Input pin capacitance	-	8	PF	
δ _{CK2}	Duty factor (t _{CK2H} /t _{CK2})	40	60	%	
t _{iS}	Input data set-up time	7	-	ns	
t _{iH}	Input data hold time	3	-	ns	
t _r	Input rise time	V _i = 0.6 to 2.6V	-	7	ns
t _f	Input fall time	V _i = 2.6 to 0.6V	-	7	ns
t _{dCK}	VCLK to VCLKx2 delay	-1	+1	ns	
C _L	Digital output load cap.	15	50	PF	
t _{oH}	Output hold time	C _L = 15pF	5	-	ns
t _{pD}	Propagation delay	C _L = 40pF	-	15	ns

The input and output timing diagrams are as follows:

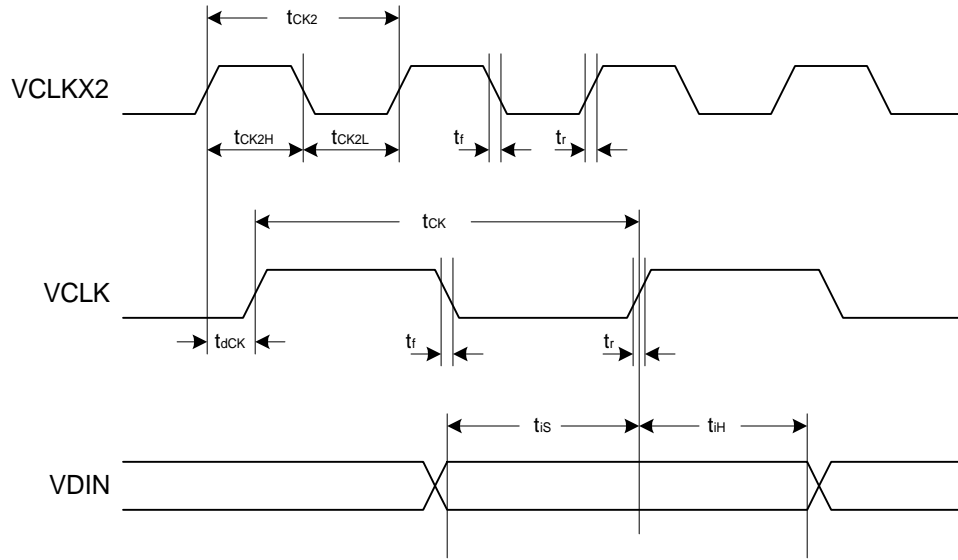

AL250-22 Input timing

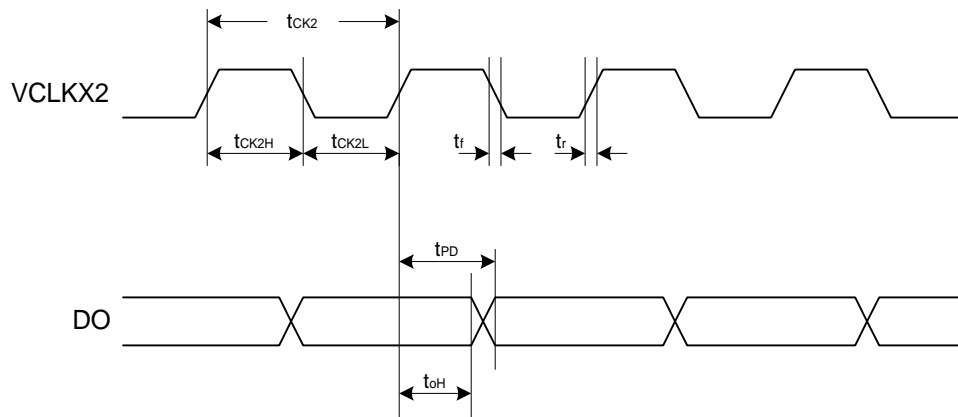

AL250-23 Output timing

8.0 AL250/251 Register Definition

The AL250/251 is powered up to a default state depending on the hardware mode-setting pins. Hardware configuration pins are disabled by setting SoftConfig (bit 4 of register 03h) to one, and configurations are decided by the values of register 02h which is software programmable.

The following is the summary of the AL250/251 control registers

Register	Addr.	R/W	Default	Function
COMPANYID	00h	R	46h	Company ID
REVISION	01h	R	00h	Revision number
BOARDCONFIG	02h	R/W	??	Board configuration
GENERAL	03h	R/W	00h	General control
FAMILY	04h	R	25h	Chip family number
CONTROL	08h	R/W	00h	Control register
STATUS	09h	R	??	Status register
BORDERRED	0Ch	R/W	00h	Border color, red channel
BORDERGREEN	0Dh	R/W	00h	Border color, green channel
BORDERBLUE	0Eh	R/W	00h	Border color, blue channel
LUTOSDCONTROL	10h	R/W	00h	LUT/OSD control
LUTOSDINDEX	11h	W	00h	LUT/OSD index
	12h			Reserved
LUTOSDDATA	13h	W	00h	LUT/OSD data
OVERLAYCTRL	14h	R/W	00h	Overlay Effect Control
OVL1RED	15h	R/W	00h	Overlay color 1, red channel
OVL1GREEN	16h	R/W	00h	Overlay color 1, green channel
OVL1BLUE	17h	R/W	FFh	Overlay color 1, blue channel
OVL2RED	18h	R/W	FFh	Overlay color 2, red channel
OVL2GREEN	19h	R/W	FFh	Overlay color 2, green channel
OVL2BLUE	1Ah	R/W	00h	Overlay color 2, blue channel
OVL3RED	1Bh	R/W	FFh	Overlay color 3, red channel
OVL3GREEN	1Ch	R/W	00h	Overlay color 3, green channel
OVL3BLUE	1Dh	R/W	00h	Overlay color 3, blue channel
OSD1HSTART	1Eh	R/W	00h	On Screen Display bitmap 1 horizontal start
OSD2HSTART	1Fh	R/W	00h	On Screen Display bitmap 2 horizontal start
HDESTART	20h	R/W	00h	Horizontal capture start
HDEEND	21h	R/W	00h	Horizontal capture end

HSYNCSTART	22h	R/W	00h	Horizontal sync. start
HSYNCEND	23h	R/W	00h	Horizontal sync. end
HTOTAL(1)	24h	R/W	00h	Horizontal total high, bit<10:3>
VDESTART	25h	R/W	00h	Vertical capture start
VDEEND	26h	R/W	00h	Vertical capture end
VSYNCSTART	27h	R/W	00h	Vertical sync. start
VSYNCEND	28h	R/W	00h	Vertical sync. end
HTOTAL(2)	29h	R/W	00h	Horizontal total low, bit<2:1>
TEST	2Ah	R/W	00h	Test register(Reserved)
HBORDERSTART	2Bh	R/W	00h	Horizontal border color start
HBORDEREND	2Ch	R/W	00h	Horizontal border color end
VBORDERSTART	2Dh	R/W	00h	Vertical border color start
VBORDEREND	2Eh	R/W	00h	Vertical border color end
OSDVSTART	2Fh	R/W	00h	On Screen Display bitmap 1 and 2 vertical start

8.1 Register Description

00h: Company ID (R) [COMPANYID]

CompanyId <7:0> Company ID (46h)

01h: Revision (R) [REVISION]

Revision <7:0> Revision number

02h: Board Configuration (R/W) [BOARDCONFIG]

If SoftConfig (Reg.#03h<4>) = 0, the hardware configuration pins values are read.

If SoftConfig (Reg.#03h<4>) = 1, the software configuration register values are read

STD <1:0> Input video standard
 00 NTSC input
 01 PAL input
 10 Automatic standard detection
 11 Reserved for analog testing

InType <2> Input video format
 0 YUV422
 1 RGB565

uvflip <3> if 1, flip UV

Square <4> 0 CCIR
 1 Square pixel

03h: General (R/W) [GENERAL]

	<0>	Reserved
	<3:1>	Reserved
SoftConfig	<4>	Enable configuration defined by software configuration register 02h. Please refer to Reg.#02h
	<7:5>	Reserved

04h: Chip Family (R) [FAMILY]

Family	<7:0>	25h, AL250/251 series
--------	-------	-----------------------

08h: Control (R/W) [CONTROL]

	<0>	Reserved
InVsPol	<1>	Input vsync polarity 0 negative polarity 1 positive polarity
InHsPol	<2>	Input hsync polarity 0 negative polarity 1 positive polarity
Softtime	<3>	Enable H & V adjustment (register 20h to 29h)
OutHsPol	<4>	Output hsync polarity 0 negative polarity 1 positive polarity
OutVsPol	<5>	Output vsync polarity 0 negative polarity 1 positive polarity
OutFormat	<7>	Output video format 0 16-bit RGB 565 1 CCIR YUV422

09h: Chip Status (R) [STATUS]

PalDetected	<0>	PAL detected
VidVs	<1>	External vsync
HRef	<2>	External href
VidHs	<3>	External hsync
GVde	<4>	Internal gvde signal
OvlCtrl0	<5>	External ovlctrl0
OvlCtrl1	<6>	External ovlctrl1

Note:

If PalDetected is always 1, the input mode is PAL. If PalDetected is not always 1, then the input mode is NTSC.

0Ch: Border Color Red (R/W) [BORDERRED]

BorderRed	<7:0>	Border color, red component
-----------	-------	-----------------------------

0Dh: Border Color Green (R/W) [BORDERGREEN]

BorderGreen	<7:0>	Border color, green component
-------------	-------	-------------------------------

0Eh: Border Color Blue (R/W) [BORDERBLUE]

BorderBlue	<7:0>	Border color, blue component
10h: LUT/OSD Control (R/W) 0x10 [LUTOSDCONTROL]		
LutOsdWSel	<1:0>	LUT/OSD table write select 00 enable LUT-red table write 01 enable LUT-green table write 10 enable LUT-blue table write 11 enable OSD (On Screen Display) bitmap write
RLutEn	<2>	LUT-red enable 0 bypass red LUT 1 enable red LUT
GLutEn	<3>	LUT-green enable 0 bypass green LUT 1 enable green LUT
BLutEn	<4>	LUT-blue enable 0 bypass blue LUT 1 enable blue LUT
BitMap1En	<6>	Bitmap 1 enable 0 hide bitmap 1 1 show bitmap 1
BitMap2En	<7>	Bitmap 2 enable 0 hide bitmap 2 1 show bitmap 2
11h: LUT/OSD Index (W) [LUTOSDINDEX]		
LutOsdIndex	<7:0>	LUT/OSD index
13h: LUT/OSD Data (W) [LUTOSDDATA]		
LutOsdData	<7:0>	LUT/OSD data
<p>To program the contents of LUT/OSD, first set Reg.#10h, bit<1:0>, then repeat writing index value to Reg.#11h, and data value to Reg.#13h.</p>		
14h: Overlay Control (R/W) [OVERLAYCTRL]		
OvlLogic1	<1:0>	Overlay logic operation between video and overlay color 1 when overlay key = "01" 00 select overlay color 1 01 video AND overlay color 1 10 video OR overlay color 1 11 video XOR overlay color 1
OvlLogic2	<3:2>	Overlay logic operation between video and overlay color 2 when overlay key = "10" 00 select overlay color 2 01 video AND overlay color 2 10 video OR overlay color 2 11 video XOR overlay color 2

OvlLogic3	<5:4>	Overlay logic operation between video and overlay color 3 when overlay key = "11" 00 select overlay color 3 01 video AND overlay color 3 10 video OR overlay color 3 11 video XOR overlay color 3
OvlLut	<7>	If 1, video will go through LUTs when ovlkey pins are "11" and OvlLogic3 settings are ignored.
15h: Overlay Color 1 Red (R/W) [OVL1RED]		
Overlay1Red	<7:0>	Overlay 1 color red component
16h: Overlay Color 1 Green (R/W) [OVL1GREEN]		
Overlay1Green	<7:0>	Overlay 1 color green component
17h: Overlay Color 1 Blue (R/W) [OVL1BLUE]		
Overlay1Blue	<7:0>	Overlay 1 color blue component
Default RGB value for overlay 1 is: (R, G, B) = (0, 0, 255), blue		
18h: Overlay Color 2 Red (R/W) [OVL2RED]		
Overlay2Red	<7:0>	Overlay 1 color red component
19h: Overlay Color 2 Green (R/W) [OVL2GREEN]		
Overlay2Green	<7:0>	Overlay 1 color green component
1Ah: Overlay Color 2 Blue (R/W) [OVL2BLUE]		
Overlay2Blue	<7:0>	Overlay 1 color blue component
Default RGB value for overlay 2 is: (R, G, B) = (255, 255, 0), yellow		
1Bh: Overlay Color 3 Red (R/W) [OVL3RED]		
Overlay3Red	<7:0>	Overlay 3 color red component
1Ch: Overlay Color 3 Green (R/W) [OVL3GREEN]		
Overlay3Green	<7:0>	Overlay 3 color green component
1Dh: Overlay Color 3 Blue (R/W) [OVL3BLUE]		
Overlay3Blue	<7:0>	Overlay 3 color blue component
Default RGB value for overlay 3 is: (R, G, B) = (255, 0, 0), red		
1Eh: On-Screen Display 1 (OSD1) Horizontal Start (R/W) [OSD1HSTART]		
Osd1HStart	<7:3>	On Screen Display bitmap 1 horizontal start. (unit: 64 pixels)
1Fh: On-Screen Display 2 (OSD2) Horizontal Start (R/W) [OSD2HSTART]		
Osd2HStart	<7:3>	On Screen Display bitmap 2 horizontal start. (unit: 64 pixels)
2Fh: On Screen Display (OSD) Vertical Start (R/W) [OSDVSTART]		

OsdVstart	<7:4>	On Screen Display bitmap 1 and 2 vertical start. (unit: 64 lines)
MeshColor	<1>	Mesh color select 0 gray mesh 1 color 3 mesh
MeshEn	<0>	Mesh background enable 0 No mesh 1 Enable mesh background

To display the OSD correctly, make sure the horizontal start does not locate between horizontal sync start and horizontal sync end, and vertical start does not locate between vertical sync start and vertical sync end.

Reg.#20h to #29h define the video capture control timing.

20h: Horizontal Capture Start (R/W) [HDESTART]

HDEStart <7:0> Horizontal capture start. (unit: 8 pixels)

21h: Horizontal Capture End (R/W) [HDEEND]

HDEEnd <7:0> Horizontal capture end. (unit: 8 pixels)

22h: Horizontal Sync Start (R/W) [HSYNCSTART]

HSyncStart <7:0> Horizontal sync start. (unit: 8 pixels)

23h: Horizontal Sync End (R/W) [HSYNCEND]

HSyncEnd <7:0> Horizontal sync end. (unit: 8 pixels)

24h: Horizontal Total High (R/W) [HTOTAL1]

HTotal10_3 <7:0> Bit 10 to bit 3 of horizontal total
Bit 2 to bit 1 are defined in Reg.#29h<1:0>

25h: Vertical Capture Start (R/W) [VDESTART]

VDEStart <7:0> Vertical capture start. (unit: 4 lines)

26h: Vertical Capture End (R/W) [VDEEND]

VDEEnd <7:0> Vertical capture end. (unit: 4 lines)

27h: Vertical Sync Start (R/W) [VSYNCSTART]

VSynStart <7:0> Vertical sync start. (unit: 4 lines)

28h: Vertical Sync End (R/W) [VSYNCEND]

VSynEnd <7:0> Vertical sync end. (unit: 4 lines)

29h: Horizontal Total Low (R/W) [HTOTAL2]

	<7:2>	Reserved
HTotal2_1	<1:0>	Bit 2 to bit 1 of horizontal total, htotal bit 0 = 0

2Ah: Test (R/W) [TEST]

testIn	<7>	Feed RGB value from 0x15, 0x16, 0x17 registers to the input
testOut	<6>	Feed RGB value from 0x15, 0x16, 0x17 registers to the output
testOvl	<5:4>	00, use hardware overlay key 01, set overlay key value to 01 10, set overlay key value to 10 11, set overlay key value to 11
	<3:0>	Reserved

2Bh: Horizontal Blank Start (R/W) [HBLANKSTART]

HBlankStart	<7:0>	Horizontal blanking start. (unit: 8 pixels)
-------------	-------	---

2Ch: Horizontal Blank End (R/W) [HBLANKEND]

HBlankEnd	<7:0>	Horizontal blanking end. (unit: 8 pixels)
-----------	-------	---

2Dh: Vertical Blank Start (R/W) [VBLANKSTART]

VBlankStart	<7:0>	Vertical blanking start. (unit: 4 lines)
-------------	-------	--

2Eh: Vertical Blank End (R/W) [VBLANKEND]

VBlankStart	<7:0>	Vertical blanking end. (unit: 4 lines)
-------------	-------	--

9.0 Board Design and Layout Considerations

The AL250/251 contains both precision analog and high-speed digital circuitry. Noise coupling from digital circuits to analog circuits may result in poor video quality. The layout should be optimized for lowest noise on the power and ground planes by shielding the digital circuitry and providing good decoupling.

It is recommended to place the AL250/251 chip close to the VGA output connector, and the video decoder close to the analog video input connectors if applicable.

9.1 Grounding

Analog and digital circuits are separated within the AL250/251 chip. To minimize system noise and prevent digital system noise from entering the analog portion, a common ground plane for all devices, including the AL250/251 is recommended. All the connections to the ground plane should have very short leads. The ground plane should be solid, not cross-hatched.

9.2 Power Planes and Power Supply Decoupling

The analog portion of the AL250/251 and any associated analog circuitry should have their own power plane, referred to as the analog power plane (AVDD). The analog power plane should be connected to the digital power plane (DVDD) at a single point through a low resistance ferrite bead.

The digital power plane should provide power to all digital logic on the PC board, and the analog power plane should provide power to all of the AL250/251 analog power pins and relevant analog circuitry.

Power supply connection pins should be individually decoupled. For best results, use 0.1 μ F ceramic chip capacitors. Lead lengths should be minimized. The power pins should be connected to the bypass capacitors before being connected to the power planes. 22 μ F capacitors should also be used between the AL250/251 power planes and the ground planes to control low-frequency power ripple.

9.3 Digital Signal and Clock Interconnect

Digital signals to the AL250/251 should be isolated as much as possible from the analog outputs and other analog circuitry. The high frequency clock reference or crystal should be handled carefully. Jitter and noise on the clock will degrade the video performance. Keep the clock paths to the decoder as short as possible to reduce noise pickup.

9.4 Analog Signal Interconnect

The AL250/251 should be located closely to the output connectors to minimize noise and reflections. Keep the critical analog traces as short and wide (20~30 mil) as possible. Digital signals, especially pixel clocks and data signals should not overlap any of the analog signal circuitry and should be kept as far apart as possible. The AL250/251 and the decoder IC should have no inputs left floating.

10.0 Mechanical Drawing

AL250: 20mm x 14mm 64-pin QFP package

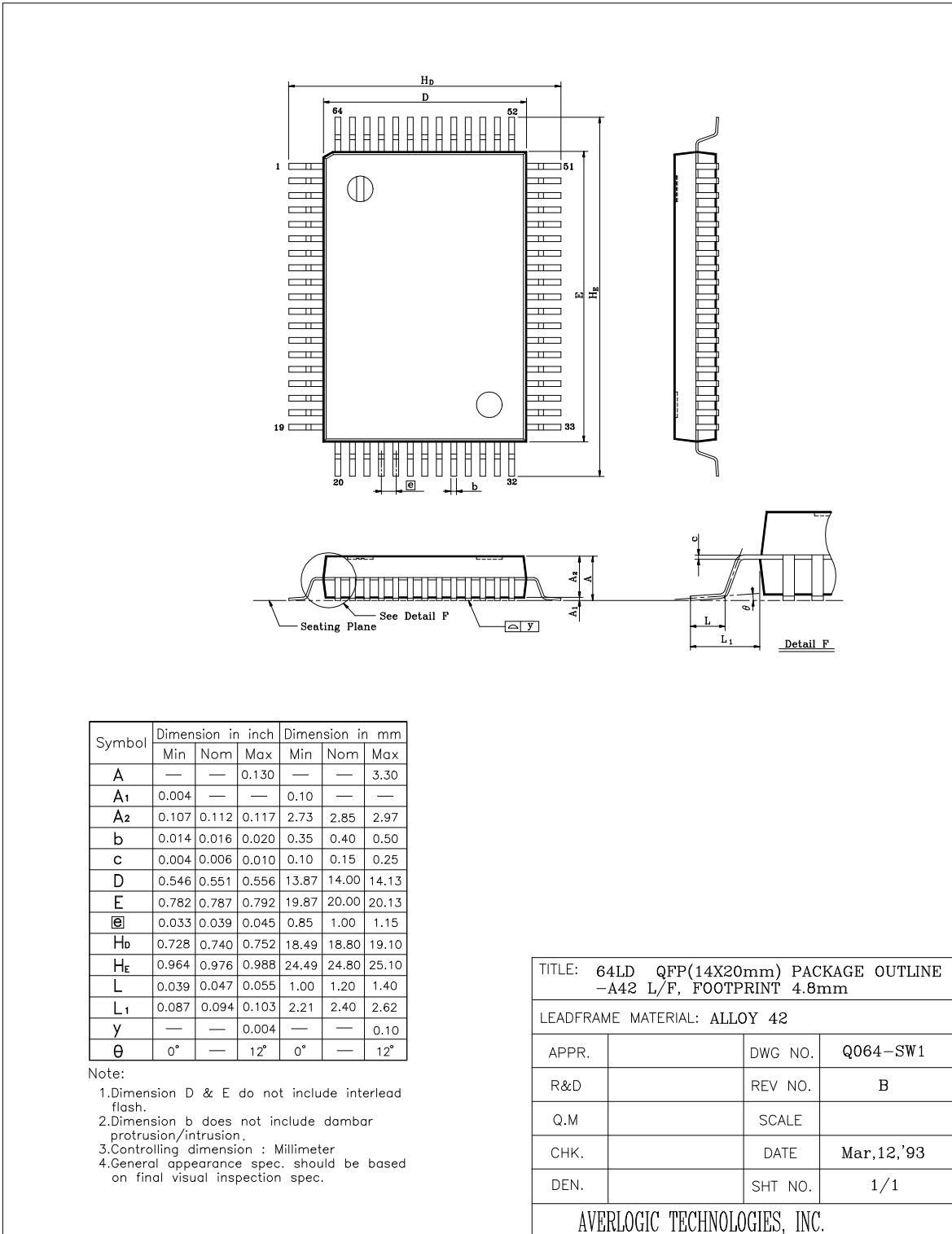

AL251: 20mm x 14mm 80-pin QFP package

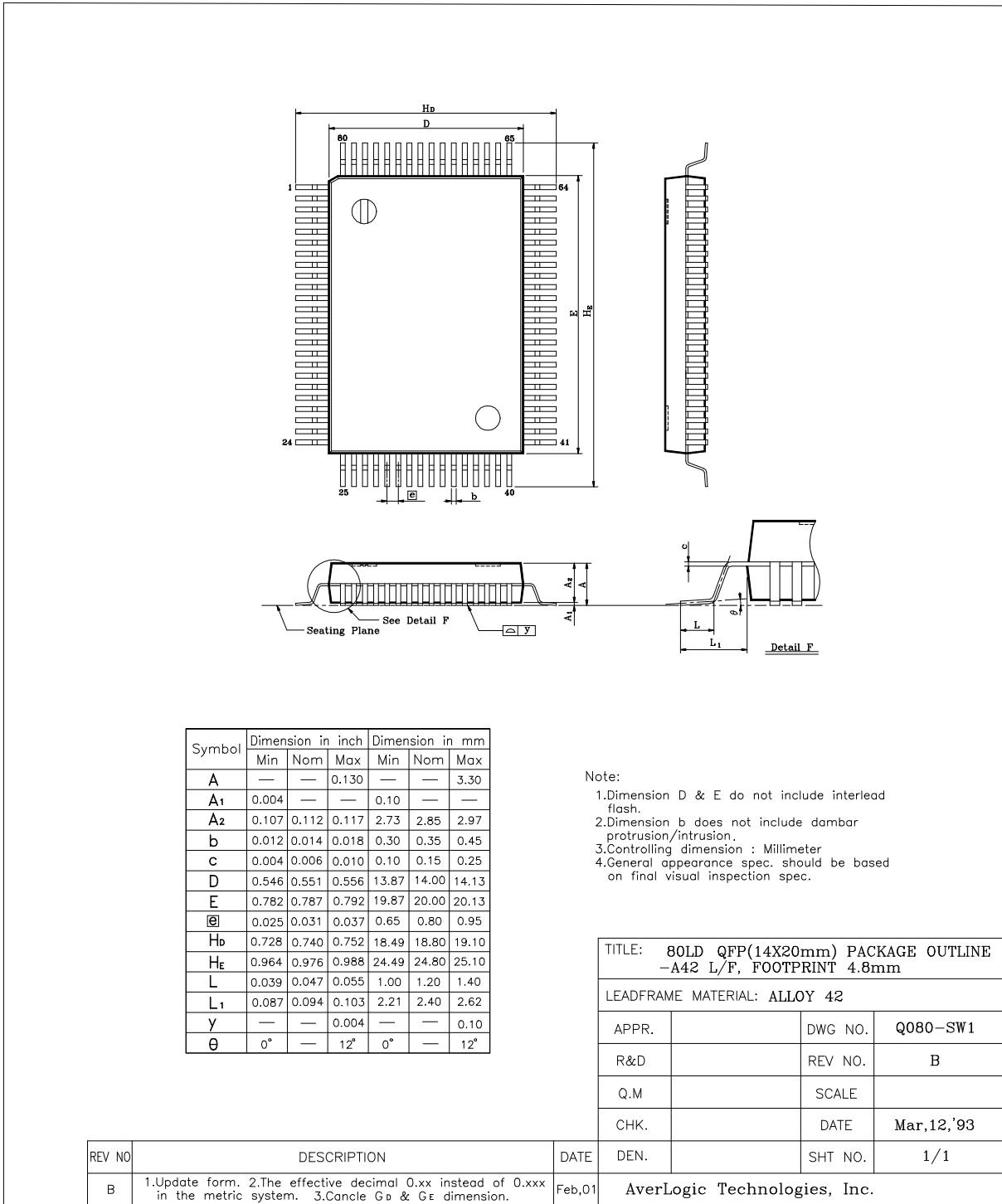

11.0 Power Consumption

The AL250/251 works at both 5V and 3.3V. The following table shows the current consumption of the AL250/251 itself and that of the whole EVB with power supply at single 5V, or 5V and 3.3V mixed (3.3V for the AL250/251 only).

	+5V	+3.3V for AL250 +5V for the rest
AL250/251 chip	92 mA (typ.)	55 mA (typ.)
AL250 EVB	280 mA (typ.)	140 mA (typ.)

Please be reminded that when lower power supply is used, the pull-down resistance to the RSET pin has to be adjusted to compensate accordingly. The lower the supply voltage is, the lower the pull-down resistance has to be. The ideal resistance value can be achieved by adjusting the RGB output to be 0.7V peak-to-peak or higher to obtain better output brightness and contrast.

For more information about the AL250/251 or other AverLogic products, please contact your local authorized representatives, visit our website, or contact us directly.

CONTACT INFORMATION

Averlogic Technologies Corp.
4F, No. 514, Sec. 2, Cheng Kung Rd., Nei-Hu Dist., Taipei, Taiwan
Tel: +886 2-27915050
Fax: +886 2-27912132
E-mail: sales@averlogic.com.tw
URL: <http://www.averlogic.com.tw>

Averlogic Technologies, Inc.
90 Great Oaks Blvd. #204, San Jose, CA 95119
USA
Tel: 1 408 361-0400
Fax: 1 408 361-0404
E-mail: sales@averlogic.com
URL: <http://www.averlogic.com>