

RF12 Universal ISM Band FSK Transceiver

DESCRIPTION

Hope's RF12 is a single chip, low power, multi-channel FSK transceiver designed for use in applications requiring FCC or ETSI conformance for unlicensed use in the 315, 433, 868 and 915 MHz bands. The RF12 transceiver produces a flexible, low cost, and highly integrated solution that does not require production alignments. The chip is a complete analog RF and baseband transceiver including a multi-band PLL synthesizer with PA, LNA, I/Q down converter mixers, baseband filters and amplifiers, and an I/Q demodulator. All required RF functions are integrated. Only an external crystal and bypass filtering are needed for operation.

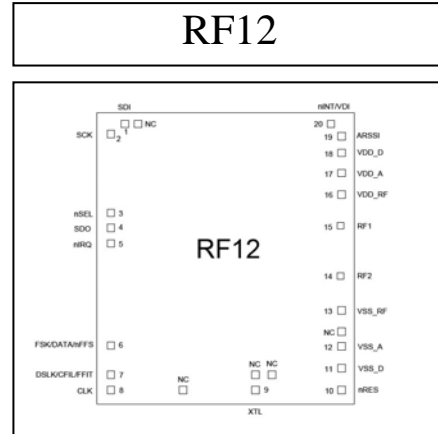

The RF12 features a completely integrated PLL for easy RF design, and its rapid settling time allows for fast frequency-hopping, bypassing multi-path fading and interference to achieve robust wireless links. The PLL's high resolution allows the usage of multiple channels in any of the bands. The receiver baseband bandwidth (BW) is programmable to accommodate various deviation, data rate and crystal tolerance requirements. The transceiver employs the Zero-IF approach with I/Q demodulation. Consequently, no external components (except crystal and decoupling) are needed in most applications.

The RF12 dramatically reduces the load on the microcontroller with the integrated digital data processing features: data filtering, clock recovery, data pattern recognition, integrated FIFO and TX data register. The automatic frequency control (AFC) feature allows the use of a low accuracy (low cost) crystal. To minimize the system cost, the RF12 can provide a clock signal for the microcontroller, avoiding the need for two crystals.

For low power applications, the RF12 supports low duty cycle operation based on the internal wake-up timer.

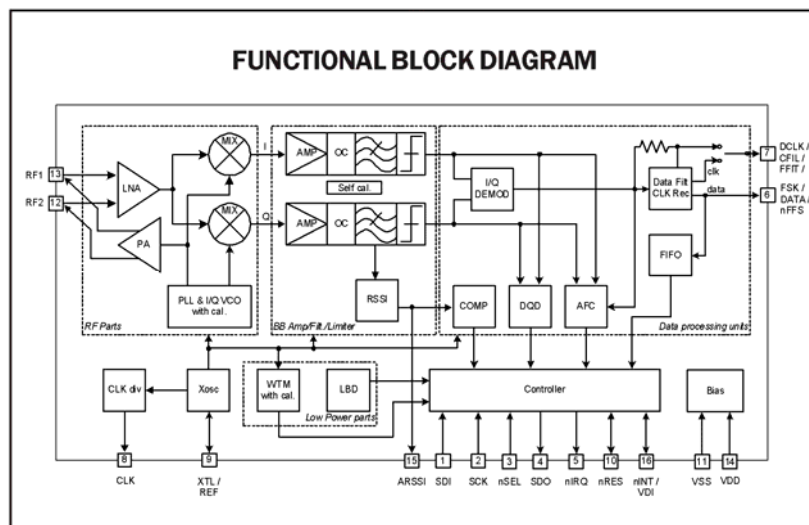

FEATURES

- Fully integrated (low BOM, easy design-in)
- No alignment required in production
- Fast-settling, programmable, high-resolution PLL synthesizer
- Fast frequency-hopping capability
- High bit rate (up to 115.2 kbps in digital mode and 256 kbps in analog mode)
- Direct differential antenna input/output
- Integrated power amplifier
- Programmable TX frequency deviation (15 to 240 KHz)
- Programmable RX baseband bandwidth (67 to 400 kHz)
- Analog and digital RSSI outputs
- Automatic frequency control (AFC)
- Data quality detection (DQD)
- Internal data filtering and clock recovery
- RX synchron pattern recognition
- SPI compatible serial control interface
- Clock and reset signals for microcontroller
- 16 bit RX Data FIFO
- Two 8 bit TX data registers
- Low power duty cycle mode
- Standard 10 MHz crystal reference
- Wake-up timer
- Low power consumption
- Low standby current (0.3 μ A)

TYPICAL APPLICATIONS

- Remote control
- Home security and alarm
- Wireless keyboard/mouse and other PC peripherals
- Toy controls
- Remote keyless entry
- Tire pressure monitoring
- Telemetry
- Personal/patient data logging
- Remote automatic meter reading

DETAILED FEATURE-LEVEL DESCRIPTION

The RF12 FSK transceiver is designed to cover the unlicensed frequency bands at 315, 433, 868 and 915 MHz. The devices facilitate compliance with FCC and ETSI requirements.

The receiver block employs the Zero-IF approach with I/Q demodulation, allowing the use of a minimal number of external components in a typical application. The RF12 incorporates a fully integrated multi-band PLL synthesizer, PA with antenna tuning, an LNA with switch-able gain, I/Q down converter mixers, baseband filters and amplifiers, and an I/Q demodulator followed by a data filter.

PLL

The programmable PLL synthesizer determines the operating frequency, while preserving accuracy based on the on-chip crystal-controlled reference oscillator. The PLL's high resolution allows the usage of multiple channels in any of the bands.

The RF VCO in the PLL performs automatic calibration, which requires only a few microseconds. Calibration always occurs when the synthesizer starts. If temperature or supply voltage changes significantly, VCO recalibration can be invoked easily. Recalibration can be initiated at any time by switching the synthesizer off and back on again.

RF Power Amplifier (PA)

The power amplifier has an open-collector differential output and can directly drive a loop antenna with a programmable output power level. An automatic antenna tuning circuit is built in to avoid costly trimming procedures and the so-called "hand effect."

LNA

The LNA has 250 Ohm input impedance, which functions well with the proposed antennas. If the RF input of the chip is connected to 50 Ohm devices, an external matching circuit is required to provide the correct matching and to minimize the noise figure of the receiver.

The LNA gain can be selected (0, -6, -14, -20 dB relative to the highest gain) according to RF signal strength. It can be useful in an environment with strong interferers.

Baseband Filters

The receiver bandwidth is selectable by programming the bandwidth (BW) of the baseband filters. This allows setting up the receiver according to the characteristics of the signal to be received.

An appropriate bandwidth can be chosen to accommodate various FSK deviation, data rate and crystal tolerance requirements. The filter structure is 7th order Butterworth low-pass with 40 dB suppression at 2*BW frequency. Offset cancellation is done by using a high-pass filter with a cut-off frequency below 7 kHz.

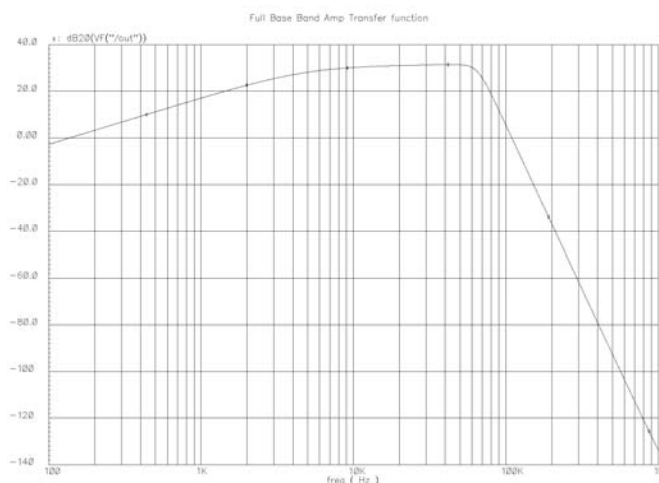

Data Filtering and Clock Recovery

Output data filtering can be completed by an external capacitor or by using digital filtering according to the final application.

Analog operation: The filter is an RC type low-pass filter followed by a Schmitt-trigger (St). The resistor (10 kOhm) and the St are integrated on the chip. An (external) capacitor can be chosen according to the actual bit rate. In this mode, the receiver can handle up to 256 kbps data rate. The FIFO can not be used in this mode and clock is not provided for the demodulated data.

Digital operation: A digital filter is used with a clock frequency at 29 times the bit rate. In this mode there is a clock recovery circuit (CR), which can provide synchronized clock to the data. Using this clock the received data can fill a FIFO. The CR has three operation modes: fast, slow, and automatic. In slow mode, its noise immunity is very high, but it has slower settling time and requires more accurate data timing than in fast mode. In automatic mode the CR automatically changes between fast and slow mode. The CR starts in fast mode, then after locking it automatically switches to slow mode (Only the digital data filter and the clock recovery use the bit rate clock. For analog operation, there is no need for setting the correct bit rate.)

Data Validity Blocks

RSSI

A digital RSSI output is provided to monitor the input signal level. It goes high if the received signal strength exceeds a given preprogrammed level. An analog RSSI signal is also available. The RSSI settling time depends on the external filter capacitor. Pin 19 is used as analog RSSI output. The digital RSSI can be monitored by reading the status register.

Analog RSSI Voltage vs. RF Input Power

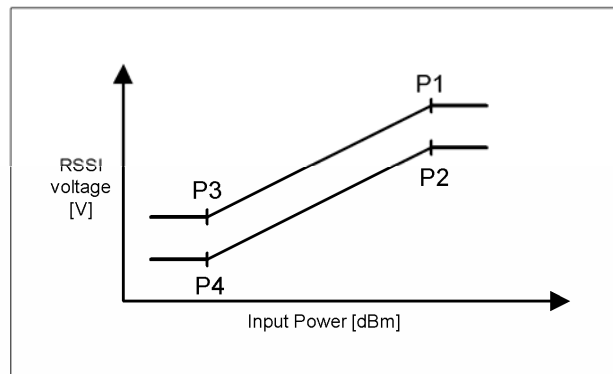

P1	-65 dBm	1300 mV
P2	-65 dBm	1000 mV
P3	-100 dBm	600 mV
P4	-100 dBm	300 mV

DQD

The Data Quality Detector is based on counting the spikes on the unfiltered received data. For correct operation, the "DQD threshold" parameter must be filled in by using the Data Filter Command.

AFC

By using an integrated Automatic Frequency Control (AFC) feature, the receiver can minimize the TX/RX offset in discrete steps, allowing the use of:

- 1, Inexpensive, low accuracy crystals
- 2, Narrower receiver bandwidth (i.e. increased sensitivity)
- 3, Higher data rate

Crystal Oscillator

The RF12 has a single-pin crystal oscillator circuit, which provides a 10 MHz reference signal for the PLL. To reduce external parts and simplify design, the crystal load capacitor is internal and programmable. Guidelines for selecting the appropriate crystal can be found later in this datasheet.

The transceiver can supply the clock signal for the microcontroller; so accurate timing is possible without the need for a second crystal.

When the microcontroller turns the crystal oscillator off by clearing the appropriate bit using the Configuration Setting Command, the chip provides a fixed number (196) of further clock pulses ("clock tail") for the microcontroller to let it go to idle or sleep mode.

Low Battery Voltage Detector

The low battery detector circuit monitors the supply voltage and generates an interrupt if it falls below a programmable threshold level. The detector circuit has 50mV hysteresis.

Wake-Up Timer

The wake-up timer has very low current consumption (1.5 μ A typical) and can be programmed from 1 ms to several days with an accuracy of $\pm 5\%$.

It calibrates itself to the crystal oscillator at every startup, and then at every 30 seconds. When the crystal oscillator is switched off, the calibration circuit switches it back on only long enough for a quick calibration (a few milliseconds) to facilitate accurate wake-up timing.

Event Handling

In order to minimize current consumption, the transceiver supports different power saving modes. Active mode can be initiated by several wake-up events (negative logical pulse on nINT input, wake-up timer timeout, low supply voltage detection, on-chip FIFO filled up or receiving a request through the serial interface).

If any wake-up event occurs, the wake-up logic generates an interrupt signal, which can be used to wake up the microcontroller, effectively reducing the period the microcontroller has to be active. The source of the interrupt can be read out from the transceiver by the microcontroller through the SDO pin.

Interface and Controller

An SPI compatible serial interface lets the user select the frequency band, center frequency of the synthesizer, and the bandwidth of the baseband signal path. Division ratio for the microcontroller clock, wake-up timer period, and low supply voltage detector threshold are also programmable. Any of these auxiliary functions can be disabled when not needed. All parameters are set to default after power-on; the programmed values are retained during sleep mode. The interface supports the read-out of a status register, providing detailed information about the status of the transceiver and the received data.

The transmitter block is equipped with an 8 bit wide TX data register. It is possible to write 8 bits into the register in burst mode and the internal bit rate generator transmits the bits out with the predefined rate.

It is also possible to store the received data bits into a FIFO register and read them out in a buffered mode.

PACKAGE PIN DEFINITIONS

Pin type key: D=digital, A=analog, S=supply, I=input, O=output, IO=input/output

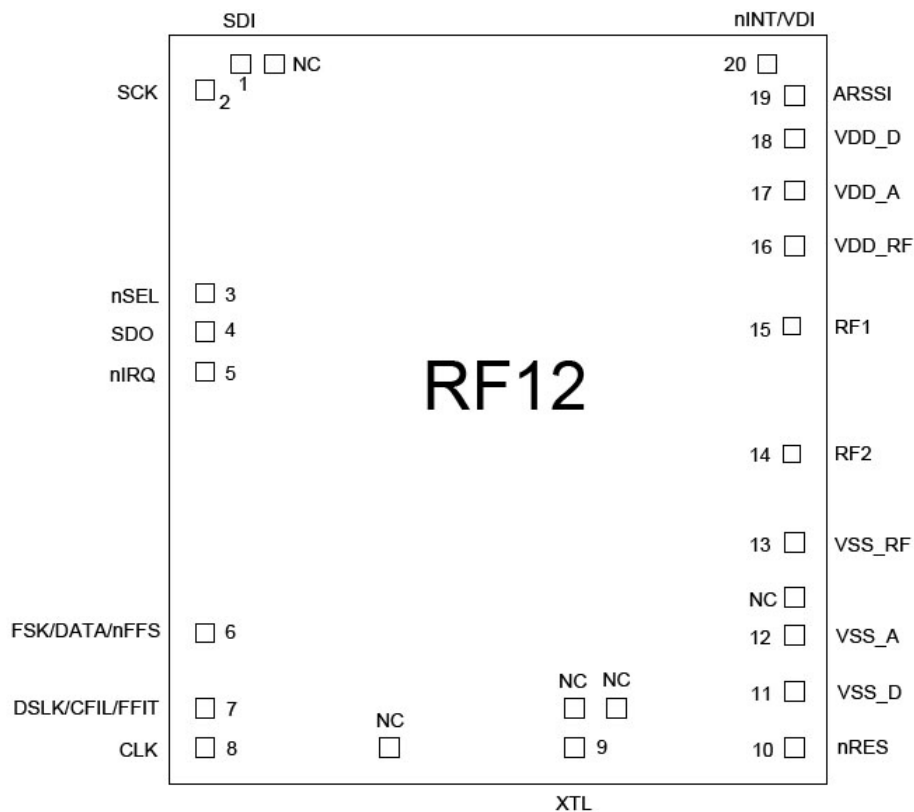

Pin	Name	Type	Function
1	SDI	DI	Data input of the serial control interface (SPI compatible)
2	SCK	DI	Clock input of the serial control interface
3	nSEL	DI	Chip select input of the serial control interface (active low)
4	SDO	DO	Serial data output with bus hold
5	nIRQ	DO	Interrupt request output (active low)
6	FSK	DI	Transmit FSK data input
	DATA	DO	Received data output (FIFO not used)
	nFFS	DI	FIFO select input (active low) In FIFO mode, when bit ef is set in Configuration Setting Command
7	DLCK	DO	Received data clock output (Digital filter used, FIFO not used)
	CFIL	AIO	External data filter capacitor connection (Analog filter used)
	FFIT	DO	FIFO interrupt (active high) Number of the bits in the RX FIFO that reach the preprogrammed limit In FIFO mode, when bit ef is set in Configuration Setting Command

8	CLK	DO	Microcontroller clock output
9	XTL	AIO	Crystal connection (the other terminal of crystal to VSS) or external reference input
	REF	AIO	External reference input. Use 33 pF series coupling capacitor
10	nRES	DIO	Open drain reset output with internal pull-up and input buffer (active low)
11	VSS_D	S	Digital VSS(Connect to VSS)
12	VSS_A	S	Analog VSS(Connect to VSS)
13	VSS_RF	S	RF VSS(Connect to VSS)
14	RF2	AIO	RF differential signal input/output
15	RF1	AIO	RF differential signal input/output
16	VDD_RF	S	RF VDD(Connect to VDD)
17	VDD_A	S	Analog VDD(Connect to VDD)
18	VDD_D	S	Digital VDD(Connect to VDD)
19	ARSSI	AO	Analog RSSI output
20	nINT	DI	Interrupt input (active low)
	VDI	DO	Valid data indicator output

Note: The actual mode of the multipurpose pins (pin 6 and 7) is determined by the TX/RX data I/O settings of the transceiver.

Typical Application

Typical application with FIFO usage

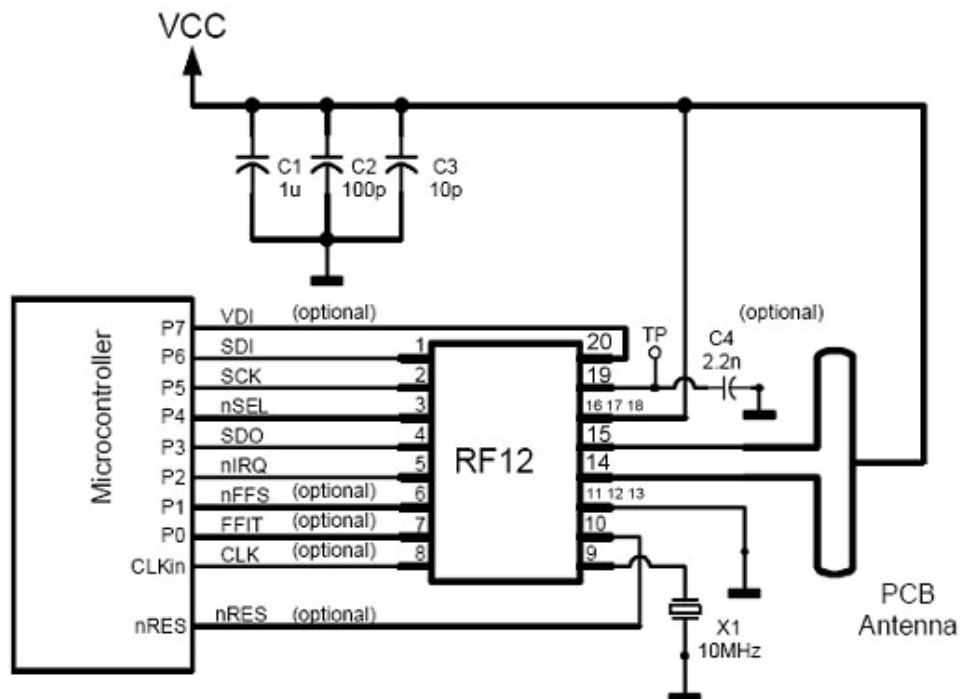

	Pin 6	Pin 7
Transmit mode el=0 in Configuration Setting Command	TX Data input	-
Transmit mode el=1 in Configuration Setting Command	Connect to logic high	-
Receive mode ef=0 in Configuration Setting Command	RX Data output	RX Data clock output
Receive mode ef=1 in Configuration Setting Command	nFFS input	FFIT output

GENERAL DEVICE SPECIFICATION

All voltages are referenced to V_{SS} , the potential on the ground reference pin VSS.

Absolute Maximum Ratings (non-operating)

Symbol	Parameter	Min	Max	Units
V_{dd}	Positive supply voltage	-0.5	6	V
V_{in}	Voltage on any pin (except RF1 and RF2)	-0.5	$V_{dd}+0.5$	V
V_{oc}	Voltage on open collector outputs (RF1, RF2)	-0.5	$V_{dd}+1.5$ (Note 1)	V
I_{in}	Input current into any pin except VDD and VSS	-25	25	mA
ESD	Electrostatic discharge with human body model		1000	V
T_{st}	Storage temperature	-55	125	°C

Recommended Operating Range

Symbol	Parameter	Min	Max	Units
V_{dd}	Positive supply voltage	2.2	5.4	V
V_{ocDC}	DC voltage on open collector outputs (RF1,RF2)		$V_{dd}+1.5$ (Note2)	V
V_{ocAC}	AC peak voltage on open collector outputs (RF1,RF2)	$V_{dd}-1.5$ (Note1)	$V_{dd}+1.5$	V
T_{op}	Ambient operating temperature	-40	85	°C

Note 1: At maximum, $V_{dd}+1.5V$ cannot be higher than 7V. At minimum, $V_{dd}-1.5V$ cannot be lower than 1.2V.

Note 2: At maximum, $V_{dd}+1.5V$ cannot be higher than 5.5V.

ELECTRICAL SPECIFICATION

(Min/max values are valid over the whole recommended operating range. Typical conditions: $T_{op}=27^{\circ}C$; $V_{dd}=V_{oc}=2.7V$)

DC Characteristics

Symbol	Parameter	Conditions/Notes	Min	Typ	Max	Units
$I_{dd_TX_0}$	Supply current (TX mode, $P_{out} = 0$ dBm)	315/433 MHz bands		13	14	mA
		868 MHz band		16	18	
		915 MHz band		17	19	
$I_{dd_TX_P_{MAX}}$	Supply current (TX mode, $P_{out} = P_{max}$)	315/433 MHz bands		21	22	mA
		868 MHz band		23	25	
		915 MHz band		24	26	

I_{dd_RX}	Supply current (RX mode)	315/433 MHz bands 868 MHz band 915 MHz band		11 12 13	13 14 15	mA
I_{pd}	Standby current (Sleep mode)	All blocks disabled		0.3		μ A
I_{lb}	Low battery voltage detector current consumption			0.5		μ A
I_{wt}	Wake-up timer current consumption			1.5		μ A
I_x	Idle current	Crystal oscillator and baseband parts are on		3	3.5	mA
V_{lb}	Low battery detect threshold	Programmable in 0.1 V steps	2.2		5.3	V
V_{lba}	Low battery detection accuracy			± 3		%
V_{il}	Digital input low level voltage				$0.3 \cdot V_{dd}$	V
V_{ih}	Digital input high level voltage		$0.7 \cdot V_{dd}$			V
I_{il}	Digital input current	$V_{il} = 0$ V	-1		1	μ A
I_{ih}	Digital input current	$V_{ih} = V_{dd}$, $V_{dd} = 5.4$ V	-1		1	μ A
V_{ol}	Digital output low level	$I_{ol} = 2$ mA			0.4	V
V_{oh}	Digital output high level	$I_{oh} = -2$ mA	$V_{dd}-0.4$			V

AC Characteristics (PLL parameters)

Symbol	Parameter	Conditions/Notes	Min	Typ	Max	Units
f_{ref}	PLL reference frequency	(Note 1)	8	10	12	MHz
f_o	Receiver LO / Transmitter carrier frequency	315MHz band, 2.5kHz resolution 433MHz band, 2.5kHz resolution 868MHz band, 5.0kHz resolution 915MHz band, 7.5kHz resolution	310.24 430.24 860.48 900.72		319.75 439.75 879.51 929.27	MHz
t_{lock}	PLL lock time	Frequency error < 1kHz after 10MHz step		20		us
$t_{st, P}$	PLL startup time	With a running crystal oscillator			250	us

AC Characteristics (Receiver)

Symbol	Parameter	Conditions/Notes	Min	Typ	Max	Units
BW	Receiver bandwidth	mode 0	60	67	75	kHz
		mode 1	120	134	150	
		mode 2	180	200	225	
		mode 3	240	270	300	
		mode 4	300	350	375	
		mode 5	360	400	450	
BR	FSK bit rate	With internal digital filters	0.6		115.2	kbps
BRA	FSK bit rate	With analog filter			256	kbps
P_{min}	Receiver Sensitivity	BER 10^{-3} , BW=67kHz, BR=1.2kbps (Note 2)		-109	-100	dBm
AFC_{range}	AFC locking range	df_{FSK} : FSK deviation in the received signal		$0.8 * df_{FSK}$		
$IIP3_{inh}$	Input IP3	In band interferers in high bands(868, 915 MHz)		-21		dBm
$IIP3_{outh}$	Input IP3	Out of band interferers $ f - f_o > 4$ MHz		-18		dBm
$IIP3_{inl}$	IIP3 (LNA -6 dB gain)	In band interferers in low bands (315, 433 MHz)		-15		dBm
$IIP3_{outl}$	IIP3 (LNA -6 dB gain)	Out of band interferers $ f - f_o > 4$ MHz		-12		dBm
P_{max}	Maximum input power	LNA: high gain	0			dBm
C_{in}	RF input capacitance			1		pF
RS_a	RSSI accuracy			+/-5		dB
RS_r	RSSI range			46		dB
C_{ARSSI}	Filter capacitor for ARSSI		1			nF
RS_{step}	RSSI programmable level steps			6		dB
RS_{resp}	DRSSI response time	Until the RSSI signal goes high after the input signal exceeds the preprogrammed limit $C_{ARSSI} = 5$ nF		500		us

AC Characteristics (Transmitter)

Symbol	Parameter	Conditions/Notes	Min	Typ	Max	Units
I_{OUT}	Open collector output DC current	Programmable	0.5		6	mA
P_{max}	Available output power with optimal antenna impedance (Note 3, 4)	In low bands In high bands		8 4		dBm
P_{out}	Typical output power	Selectable in 3 dB steps (Note 5)	$P_{max}-21$		P_{max}	dBm
P_{sp}	Spurious emission	At max power with loop antenna (Note 6)			-50	dBc

C_o	Output capacitance (set by the automatic antenna tuning circuit)	In low bands In high bands	2 2.1	2.6 2.7	3.2 3.3	pF
Q_o	Quality factor of the output capacitance	In low bands In high bands	13 8	15 10	17 12	
L_{out}	Output phase noise	100 kHz from carrier 1 MHz from carrier		-75 -85		dBc/Hz
BR	FSK bit rate				256	kbps
df_{fsk}	FSK frequency deviation	Programmable in 15 kHz steps	15		240	kHz

AC Characteristics (Turn-on/Turnaround timings)

Symbol	Parameter	Conditions/Notes	Min	Typ	Max	Units
t_{sx}	Crystal oscillator startup time	Crystal ESR < 100			5	ms
$T_{tx_rx_XTAL_ON}$	Transmitter - Receiver turnover time	Synthesizer off, crystal oscillator on during TX/RX change with 10 MHz step		450		us
$T_{rx_tx_XTAL_ON}$	Receiver - Transmitter turnover time	Synthesizer off, crystal oscillator on during RX/TX change with 10 MHz step		350		us
$T_{tx_rx_SYNT_ON}$	Transmitter - Receiver turnover time	Synthesizer and crystal oscillator on during TX/RX change with 10 MHz step		425		us
$T_{rx_tx_SYNT_ON}$	Receiver - Transmitter turnover time	Synthesizer and crystal oscillator on during RX/TX change with 10 MHz step		300		us

AC Characteristics (Others)

Symbol	Parameter	Conditions/Notes	Min	Typ	Max	Units
C_{xl}	Crystal load capacitance, see crystal selection guide	Programmable in 0.5 pF steps, tolerance +/- 10%	8.5		16	pF
t_{POR}	Internal POR timeout	After V_{dd} has reached 90% of final value (Note 7)			100	ms
t_{PBt}	Wake-up timer clock period	Calibrated every 30 seconds	0.95		1.05	ms
$C_{in, D}$	Digital input capacitance				2	pF
$t_{r, f}$	Digital output rise/fall time	15 pF pure capacitive load			10	ns

Note 1: Not using a 10 MHz crystal is allowed but not recommended because all crystal referred timing and frequency parameters will change accordingly.

Note 2: See the BER diagrams in the measurement results section for detailed information (Not available at this time).

Note 3: See matching circuit parameters and antenna design guide for information.

Note 4: Optimal antenna admittance/impedance:

RF12	Yantenna [S]	Zantenna [Ohm]	Lantenna [nH]
315 MHz	1.5E-3 -j5.14E-3	52 + j179	98.00
433 MHz	1.4E-3 -j7.1E-3	27 + j136	52.00
868 MHz	2E-3 -j1.5E-2	8.7 + j66	12.50
915 MHz	2.2E-3 -j1.55E-2	9 + j63	11.20

Note 5: Adjustable in 8 steps.

Note 6: With selective resonant antennas

Note 7: During this period, commands are not accepted by the chip.

CONTROL INTERFACE

Commands to the transmitter are sent serially. Data bits on pin SDI are shifted into the device upon the rising edge of the clock on pin SCK whenever the chip select pin nSEL is low. When the nSEL signal is high, it initializes the serial interface. All commands consist of a command code, followed by a varying number of parameter or data bits. All data are sent MSB first (e.g. bit 15 for a 16-bit command). Bits having no influence (don't care) are indicated with X. The Power On Reset (POR) circuit sets default values in all control and command registers.

The receiver will generate an interrupt request (IT) for the microcontroller - by pulling the nIRQ pin low - on the following events:

- The TX register is ready to receive the next byte (RGIT)
- The FIFO has received the preprogrammed amount of bits (FFIT)
- Power-on reset (POR)
- FIFO overflow (FFOV) / TX register under run (RGUR)
- Wake-up timer timeout (WKUP)
- Negative pulse on the interrupt input pin nINT (EXT)
- Supply voltage below the preprogrammed value is detected (LBD)

FFIT and FFOV are applicable when the FIFO is enabled. RGIT and RGUR are applicable only when the TX register is enabled. To identify the source of the IT, the status bits should be read out.

Timing Specification

Symbol	Parameter	Minimum Value [ns]
t _{CH}	Clock high time	25
t _{CL}	Clock low time	25
t _{SS}	Select setup time (nSEL falling edge to SCK rising edge)	10
t _{SH}	Select hold time (SCK falling edge to nSEL rising edge)	10
t _{SHI}	Select high time	25
t _{DS}	Data setup time (SDI transition to SCK rising edge)	5
t _{DH}	Data hold time (SCK rising edge to SDI transition)	5
t _{OD}	Data delay time	10

Timing Diagram

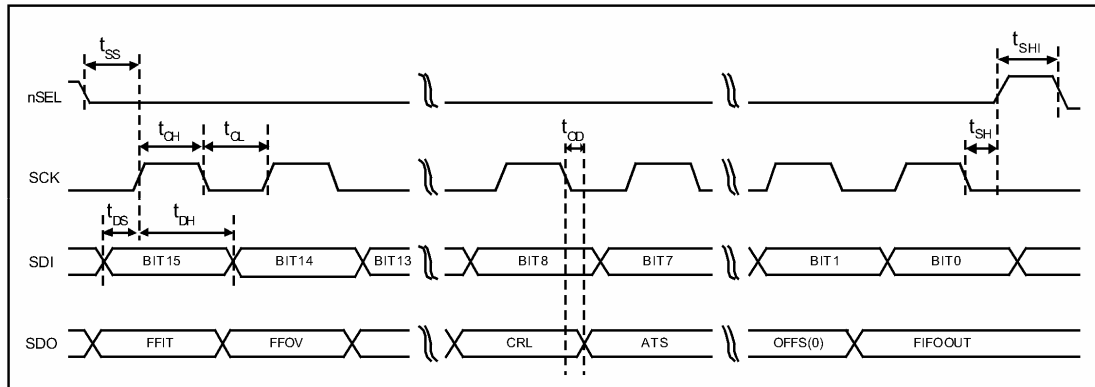

Control Commands

	Control Command	Related Parameters/Functions	Related control bits
1	Configuration Setting Command	Frequency band, crystal oscillator load capacitance, baseband filter bandwidth, etc.	el, ef, b1 to b0, x3 to x0
2	Power Management Command	Receiver/Transmitter mode change, synthesizer, xtal osc, PA, wake-up timer, clock output can be enabled here	er, ebb, et, es, ex, eb, ew, dc
3	Frequency Setting Command	Data frequency of the local oscillator/carrier signal	f11 to f0
4	Data Rate Command	Bit rate	cs, r6 to r0
5	Receiver Control Command	Function of pin 20, Valid Data Indicator, baseband bw, LNA gain, digital RSSI threshold	p20, d1 to d0, i2 to i0, g1 to g0, r2 to r0
6	Data Filter Command	Data filter type, clock recovery parameters	a1, ml, s1 to s0, f2 to f0
7	FIFO and Reset Mode Command	Data FIFO IT level, FIFO start control, FIFO enable and FIFO fill enable	f3 to f0, s1 to s0, ff, fe
8	Receiver FIFO Read Command	RX FIFO can be read with this command	
9	AFC Command	AFC parameters	a1 to a0, r11 to r10, st, fi, oe, en
10	TX Configuration Control Command	Modulation parameters, output power, ea	mp, m3 to m0, p2 to p0
11	Transmitter Register Write Command	TX data register can be written with this command	t7 to t0
12	Wake-Up Timer Command	Wake-up time period	r4 to r0, m7 to m0
13	Low Duty-Cycle Command	Enable low duty-cycle mode. Set duty-cycle.	d6 to d0, en

14	Low Battery Detector and Microcontroller Clock Divider Command	LBD voltage and microcontroller clock division ratio	d2 to d0, v4 to v0
15	Status Read Command	Status bits can be read out	

In general, setting the given bit to one will activate the related function. In the following tables, the POR column shows the default values of the command registers after power-on.

Description of the Control Commands

1. Configuration Setting Command

bit	15	14	13	12	11	10	9	8	7	6	5	4	3	2	1	0	POR
	1	0	0	0	0	0	0	0	el	ef	b1	b0	x3	x2	x1	x0	8008h

Bit el enables the internal data register. If the data register is used the FSK pin must be connected to logic high level.

Bit ef enables the FIFO mode. If ef=0 then DATA (pin 6) and DCLK (pin 7) are used for data and data clock output.

b1	b0	Frequency Band [MHz]
0	0	315
0	1	433
1	0	868
1	1	915

x3	x2	x1	x0	Crystal Load Capacitance [pF]
0	0	0	0	8.5
0	0	0	1	9.0
0	0	1	0	9.5
0	0	1	1	10.0
...				
1	1	1	0	15.5
1	1	1	1	16.0

2. Power Management Command

bit	15	14	13	12	11	10	9	8	7	6	5	4	3	2	1	0	POR
	1	0	0	0	0	0	1	0	er	ebb	et	es	ex	eb	ew	dc	8208h

Bit	Function of the control bit	Related blocks
er	Enables the whole receiver chain	RF front end, baseband, synthesizer, oscillator
ebb	The receiver baseband circuit can be separately switched on	Baseband
et	Switches on the PLL, the power amplifier, and starts the transmission (If TX register is enabled)	Power amplifier, synthesizer, oscillator
es	Turns on the synthesizer	Synthesizer
ex	Turns on the crystal oscillator	Crystal oscillator
eb	Enables the low battery detector	Low battery detector
ew	Enables the wake-up timer	Wake-up timer
dc	Disables the clock output (pin 8)	Clock output buffer

The ebb, es, and ex bits are provided to optimize the TX to RX or RX to TX turnaround time.

Logic connections between power control bits:

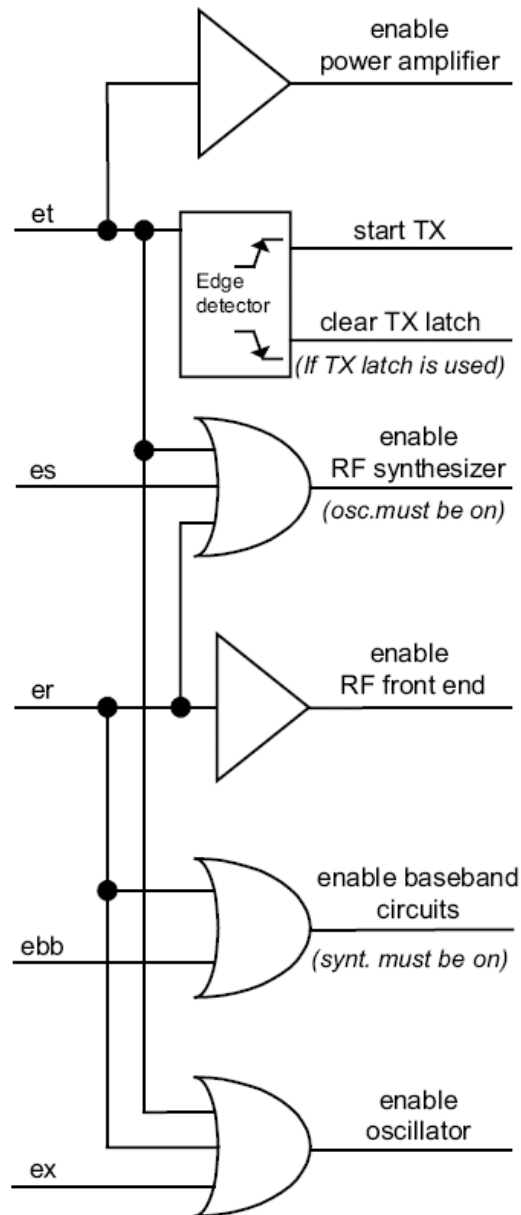

3. Frequency Setting Command

bit	15	14	13	12	11	10	9	8	7	6	5	4	3	2	1	0	POR
	1	0	1	0	f11	f10	f9	f8	f7	f6	f5	f4	f3	f2	f1	f0	A680h

The 12-bit parameter F (bits f11 to f0) should be in the range of 96 and 3903. When F value sent is out of range, the previous value is kept. The synthesizer band center frequency f_0 can be calculated as:

$$f_0 = 10 * C1 * (C2 + F/4000) \text{ [MHz]}$$

The constants C1 and C2 are determined by the selected band as:

Band [MHz]	C1	C2
315	1	31
433	1	43
868	2	43
915	3	30

4. Data Rate Command

bit	15	14	13	12	11	10	9	8	7	6	5	4	3	2	1	0	POR
	1	1	0	0	0	1	1	0	cs	r6	r5	r4	r3	r2	r1	r0	C623h

The actual bit rate in transmit mode and the expected bit rate of the received data stream in receive mode is determined by the 7-bit parameter R (bits r6 to r0) and bit cs.

$$BR = 10000 / 29 / (R+1) / (1+cs*7) \text{ [kbps]}$$

In the receiver set R according to the next function:

$$R = (10000 / 29 / (1+cs*7) / BR) - 1, \text{ where BR is the expected bit rate in kbps.}$$

Apart from setting custom values, the standard bit rates from 600 bps to 115.2 kbps can be approximated with small error. Data rate accuracy requirements:

- Clock recovery in slow mode: $\Delta BR/BR < 1/(29*N_{bit})$
- Clock recovery in fast mode: $\Delta BR/BR < 3/(29*N_{bit})$

BR is the bit rate set in the receiver and ΔBR is the bit rate difference between the transmitter and the receiver. N_{bit} is the maximal number of consecutive ones or zeros in the data stream. It is recommended for long data packets to include enough 1/0 and 0/1 transitions, and be careful to use the same division ratio in the receiver and in the transmitter.

5. Receiver Control Command

bit	15	14	13	12	11	10	9	8	7	6	5	4	3	2	1	0	POR
	1	0	0	1	0	p20	d1	d0	i2	i1	i0	g1	g0	r2	r1	r0	9080h

Bit 10 (p20): pin20 function select

p20	Function of pin 20
0	Interrupt input
1	VDI output

Bits 9-8 (d1 to d0): VDI (valid data indicator) signal response time setting:

d1	d0	Response
0	0	Fast
0	1	Medium
1	0	Slow
1	1	Always on

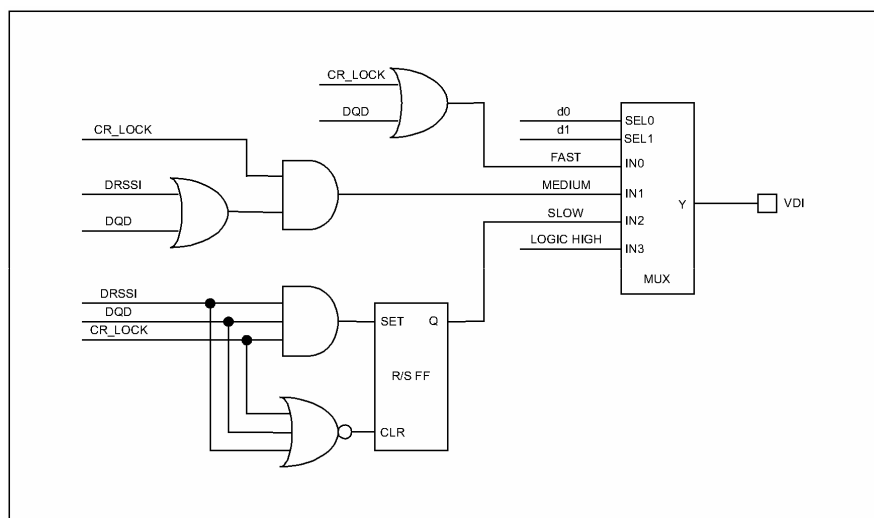

Bits 7-5 (i2 to i0): Receiver baseband bandwidth (BW) select:

i2	i1	i0	BW [kHz]
0	0	0	reserved
0	0	1	400
0	1	0	340
0	1	1	270
1	0	0	200
1	0	1	134
1	1	0	67
1	1	1	reserved

Bits 2-0 (r2 to r0): RSSI detector threshold:

r2	r1	r0	RSSIsetth [dBm]
0	0	0	-103
0	0	1	-97
0	1	0	-91
0	1	1	-85
1	0	0	-79
1	0	1	-73
1	1	0	-67
1	0	1	-61

Bits 4-3 (g1 to g0): LNA gain select:

g1	g0	relative to maximum [dB]
0	0	0
0	1	-6
1	0	-14
1	1	-20

The RSSI threshold depends on the LNA gain, the real RSSI threshold can be calculated:

$$RSSI_{th} = RSSI_{setth} + G_{LNA}$$

6. Data Filter Command

bit	15	14	13	12	11	10	9	8	7	6	5	4	3	2	1	0	POR
	1	1	0	0	0	0	1	0	al	ml	1	s	1	f2	f1	f0	C22Ch

Bit 7 (al) : Clock recovery (CR) auto lock control, if set.

CR will start in fast mode, then after locking it will automatically switch to slow mode.

Bit 6 (ml): Clock recovery lock control

1: fast mode, fast attack and fast release (6 to 8 bit preamble (1010...) is recommended)

0: slow mode, slow attack and slow release (12 to 16 bit preamble is recommended)

Using the slow mode requires more accurate bit timing (see Data Rate Command).

Bits 4 (s): Select the type of the data filter:

s	Filter Type
0	Digital filter
1	Analog RC filter

Digital: This is a digital realization of an analog RC filter followed by a comparator with hysteresis. The time constant is automatically adjusted to the bit rate defined by the Data Rate Command.

Note: Bit rate can not exceed 115 kbps in this mode. Analog RC filter: The demodulator output is fed to pin 7 over a 10 kOhm resistor. The filter cut-off frequency is set by the external capacitor connected to this pin and VSS. $C = 1 / (3 * R * \text{Bit Rate})$, therefore the suggested value for 9600 bps is 3.3 nF

Note: If analog RC filter is selected the internal clock recovery circuit and the FIFO can not be used.

Bits 2-0 (f2 to f0): DQD threshold parameter.

Note: To let the DQD report "good signal quality" the threshold parameter should be less than 4 in the case when the bit-rate is close to the deviation. At higher deviation/bit-rate settings higher threshold parameter can report "good signal quality" as well.

7. FIFO and Reset Mode Command

bit	15	14	13	12	11	10	9	8	7	6	5	4	3	2	1	0	POR
	1	1	0	0	1	0	1	0	f3	f2	f1	f0	0	al	ff	dr	CA80h

Bits 7-4 (f4 to f0): FIFO IT level. The FIFO generates IT when the number of received data bits reaches this level.

Bit 2 (al): Set the input of the FIFO fill start condition:

al	
0	Synchron pattern
1	Always fill

Note: Synchron pattern is 2DD4h.

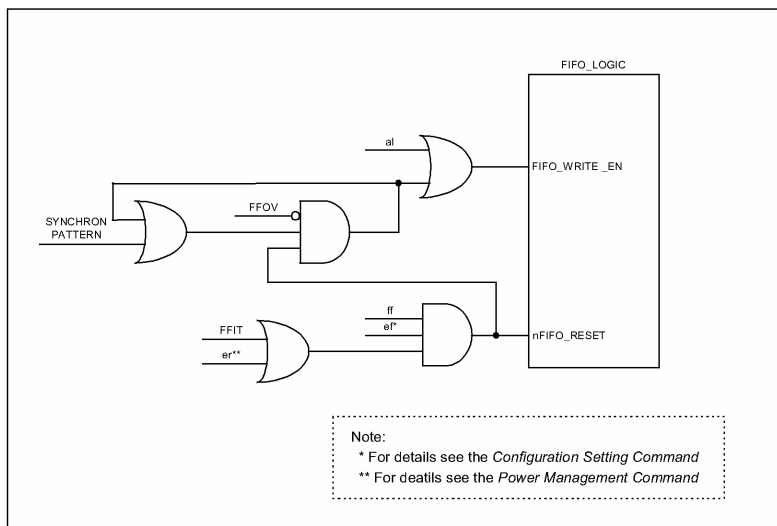

Note: For details see the *Configuration Setting Command*

For details see the *Power Management Command*

Bit 1 (ff): FIFO fill will be enabled after synchron pattern reception. The FIFO fill stops when this bit is cleared.

Bit 0 (dr): Disables the highly sensitive RESET mode. If this bit is cleared, a 200 mV glitch in the power supply may cause a system reset.

Note: To restart the synchron pattern recognition, bit 1 should be cleared and set.

8. Receiver FIFO Read Command

bit	15	14	13	12	11	10	9	8	7	6	5	4	3	2	1	0	POR
	1	0	1	1	0	0	0	0	0	0	0	0	0	0	0	0	B000h

With this command, the controller can read 8 bits from the receiver FIFO. Bit 6 (ef) must be set in Configuration Setting Command.

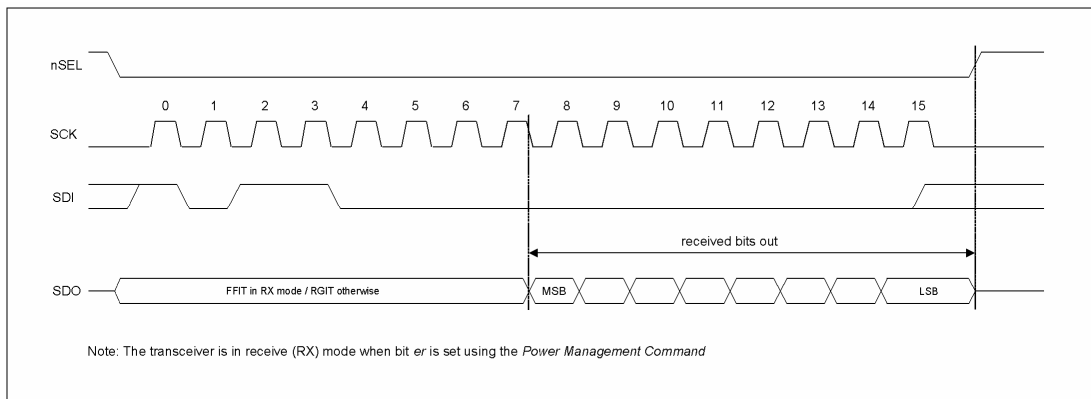

Note: The transceiver is in receive (RX) mode when bit er is set using the Power Management Command

9. AFC Command

bit	15	14	13	12	11	10	9	8	7	6	5	4	3	2	1	0	POR
	1	1	0	0	0	1	0	0	a1	a0	r1	r0	st	fi	oe	en	C4F7h

Bit 7-6 (a1 to a0): Automatic operation mode selector:

a1	a0	
0	0	Auto mode off (Strobe is controlled by microcontroller)
0	1	Runs only once after each power-up
1	0	Keep the foffset only during receiving (VDI=high)
1	1	Keep the foffset value independently from the state of the VDI signal

Bit 5-4 (r1 to r0): Range limit. Limits the value of the frequency offset register to the next values:

r1	r0	Max deviation
0	0	No restriction
0	1	+15 f_{res} to -16 f_{res}
1	0	+7 f_{res} to -8 f_{res}
1	1	+3 f_{res} to -4 f_{res}

f_{res} :

- 315, 433 MHz bands: 2.5 kHz
- 868 MHz band: 5 kHz
- 915 MHz band: 7.5 kHz

Bit 3 (st): Strobe edge, when st goes to high, the actual latest calculated frequency error is stored into the offset register of the AFC block.

Bit 2 (fi): Switches the circuit to high accuracy (fine) mode. In this case, the processing time is about twice longer, but the measurement uncertainty is about the half.

Bit 1 (oe): Enables the frequency offset register. It allows the addition of the offset register to the frequency control word of the PLL.

Bit 0 (en): Enables the calculation of the offset frequency by the AFC circuit.

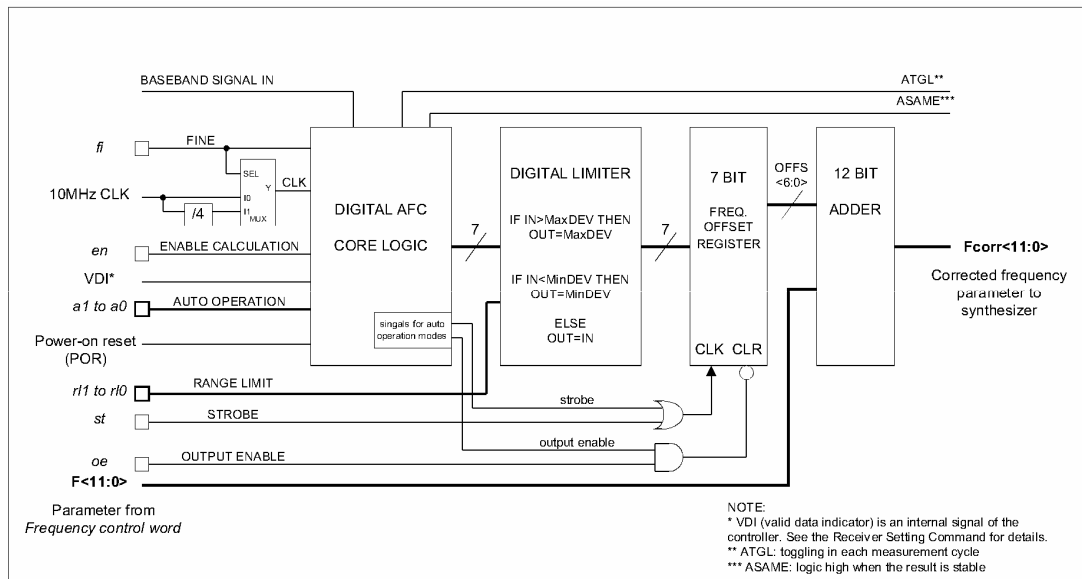
**Note:**

Lock bit is high when the AFC loop is locked, f same bit indicates when two subsequent measuring results are the same, toggle bit changes state in every measurement cycle.

In automatic operation mode (no strobe signal is needed from the microcontroller to update the output offset register) the AFC circuit is automatically enabled when the VDI indicates potential incoming signal during the whole measurement cycle and the circuit measures the same result in two subsequent cycles.

There are three operation modes, example from the possible application:

1, (a1=0, a0=1) The circuit measures the frequency offset only once after power up. In this way extended TX-RX maximum distance can be achieved.

Possible application:

In the final application, when the user inserts the battery, the circuit measures and compensates for the frequency offset caused by the crystal tolerances. This method allows for the use of a cheaper quartz in the application and provides protection against tracking an interferer.

2a, (a1=1, a0=0) The circuit automatically measures the frequency offset during an initial effective low data rate pattern –easier to receive (i.e.: 00110011) of the package and changes the receiving frequency accordingly. The further part of the package can be received by the corrected frequency settings.

2b, (a1=1, a0=0) The transmitter must transmit the first part of the packet with a step higher deviation and later there is a possibility to reduce it.

In both cases (2a and 2b), when the VDI indicates poor receiving conditions (VDI goes low), the output register is automatically cleared. Use these settings when receiving signals from different transmitters transmitting in the same nominal frequencies.

3, (a1=1, a0=1) It's the same as 2a and 2b modes, but suggested to use when a receiver operates with only one transmitter. After a complete measuring cycle, the measured value is kept independently of the state of the VDI signal.

10. TX Configuration Control Command

bit	15	14	13	12	11	10	9	8	7	6	5	4	3	2	1	0	POR
	1	0	0	1	1	0	0	mp	m3	m2	m1	m0	0	p2	p1	p0	9800h

Bits 8-4 (mp, m3 to m0):

FSK modulation parameters:

The resulting output frequency can be calculated as:

$$f_{out} = f_0 + (-1)^{SIGN} * (M + 1) * (15 \text{ kHz})$$

where:

f_0 is the channel center frequency (see the Frequency Setting Command)

M is the four bit binary number <m3: m0>

SIGN = (mp) XOR (FSK input)

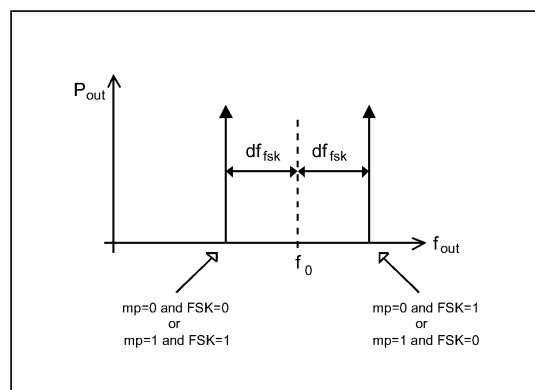

Bits 2-0 (p2 to p0): Output power:

p2	p1	p0	Relative Output Power [dB]
0	0	0	0
0	0	1	-3
0	1	0	-6
0	1	1	-9
1	0	0	-12
1	0	1	-15
1	1	0	-18
1	1	1	-21

The output power given in the table is relative to the maximum available power, which depends on the actual antenna impedance.

11. Transmitter Register Write Command

bit	15	14	13	12	11	10	9	8	7	6	5	4	3	2	1	0	POR
	1	0	1	1	1	0	0	0	t7	t6	t5	t4	t3	t2	t1	t0	B8AAh

With this command, the controller can write 8 bits (t7 to t0) to the transmitter data register. Bit 7 (el) must be set in Configuration Setting Command.

12. Wake-Up Timer Command

bit	15	14	13	12	11	10	9	8	7	6	5	4	3	2	1	0	POR
	1	1	1	r4	r3	r2	r1	r0	m7	m6	m5	m4	m3	m2	m1	m0	E196h

The wake-up time period can be calculated by (m7 to m0) and (r4 to r0):

$$T_{\text{wake-up}} = M * 2^R \text{ [ms]}$$

Note:

- For continual operation the *er* bit should be cleared and set at the end of every cycle.
- For future compatibility, use R in a range of 0 and 29.

13. Low Duty-Cycle Command

bit	15	14	13	12	11	10	9	8	7	6	5	4	3	2	1	0	POR
	1	1	0	0	1	0	0	r0	d6	d5	d4	d3	d2	d1	d0	en	C80Eh

With this command, Low Duty-Cycle operation can be set in order to decrease the average power consumption in receiver mode. The time cycle is determined by the Wake-Up Timer Command. The Duty-Cycle can be calculated by using (d6 to d0) and M. (M is parameter in a Wake-Up Timer Command.)

$$\text{Duty-Cycle} = (D * 2 + 1) / M * 100\%$$

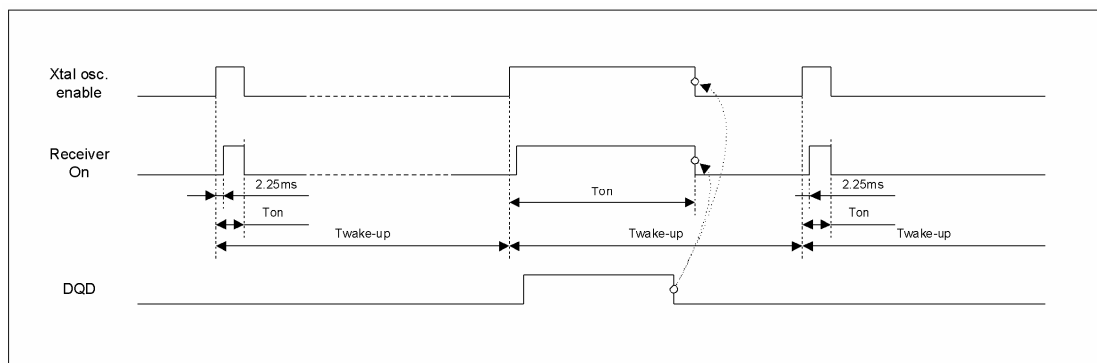

Bit 0 (en): Enables the Low Duty-Cycle Mode. Wake-up timer interrupt not generated in this mode.

Note: In this operation mode, bit *er* must be cleared and bit *ew* must be set in the Power Management Command.

14. Low Battery Detector and Microcontroller Clock Divider Command

bit	15	14	13	12	11	10	9	8	7	6	5	4	3	2	1	0	POR
	1	1	0	0	0	0	0	0	d2	d1	d0	v4	v3	v2	v1	v0	C000h

The 5 bit parameter (v4 to v0) represents the value V, which defines the threshold voltage V_{lb} of the detector:

$$V_{lb} = 2.2 + V * 0.1 \text{ [V]}$$

Clock divider configuration:

d2	d1	d0	Clock Output Frequency [M Hz]
0	0	0	1
0	0	1	1.25
0	1	0	1.66
0	1	1	2

1	0	0	2.5
1	0	1	3.33
1	1	0	5
1	1	1	10

The low battery detector and the clock output can be enabled or disabled by bits eb and dc, respectively, using the Power Management Command.

15. Status Read Command

The read command starts with a zero, whereas all other control commands start with a one. If a read command is identified, the status bits will be clocked out on the SDO pin as follows:

Status Register Read Sequence with FIFO Read Example:

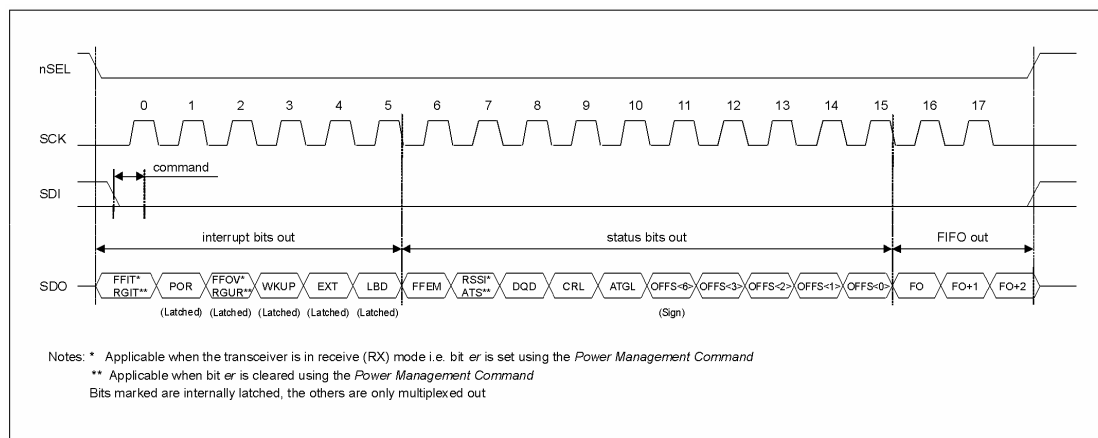

RGIT	TX register is ready to receive the next byte (Can be cleared by Transmitter Register Write Command)
FFIT	The number of data bits in the RX FIFO has reached the pre-programmed limit (Can be cleared by any of the FIFO read methods)
POR	Power-on reset (Cleared after Status Read Command)
RGUR	TX register under run, register over write (Cleared after Status Read Command)
FFOV	RX FIFO overflow (Cleared after Status Read Command)
WKUP	Wake-up timer overflow (Cleared after Status Read Command)
EXT	Logic level on interrupt pin (pin 16) changed to low (Cleared after Status Read Command)
LBD	Low battery detect, the power supply voltage is below the pre-programmed limit
FFEM	FIFO is empty
ATS	Antenna tuning circuit detected strong enough RF signal
RSSI	The strength of the incoming signal is above the pre-programmed limit
DQD	Data quality detector output
CRL	Clock recovery locked
ATGL	Toggling in each AFC cycle
OFFS(6)	MSB of the measured frequency offset (sign of the offset value)
OFFS(3)-OFFS(0)	Offset value to be added to the value of the frequency control parameter (Four LSB bits)

TX REGISTER BUFFERED DATA TRANSMISSION

In this operating mode (enabled by bit *el*, the Configuration Control Command) the TX data is clocked into one of the two 8-bit data registers. The transmitter starts to send out the data from the first register (with the given bit rate) when bit *et* is set with the Power Management Command. The initial value of the data registers (AAh) can be used to generate preamble. During this mode, the SDO pin can be monitored to check whether the register is ready (SDO is high) to receive the next byte from the microcontroller.

TX register simplified block diagram (before transmit)

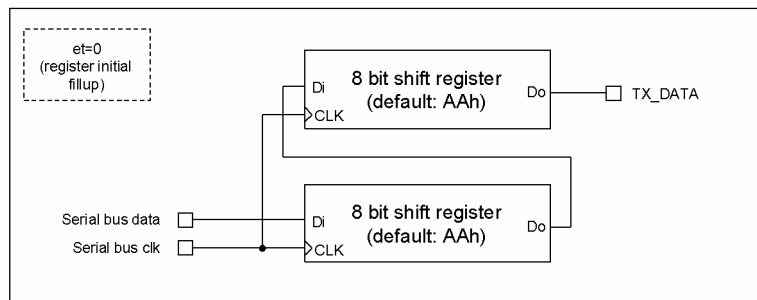

TX register simplified block diagram (during transmit)

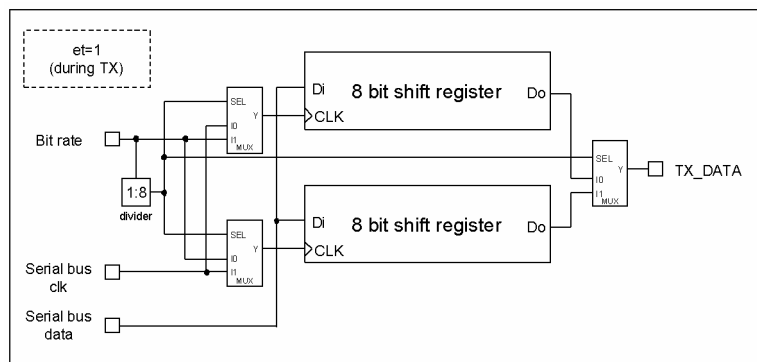

Typical TX register usage

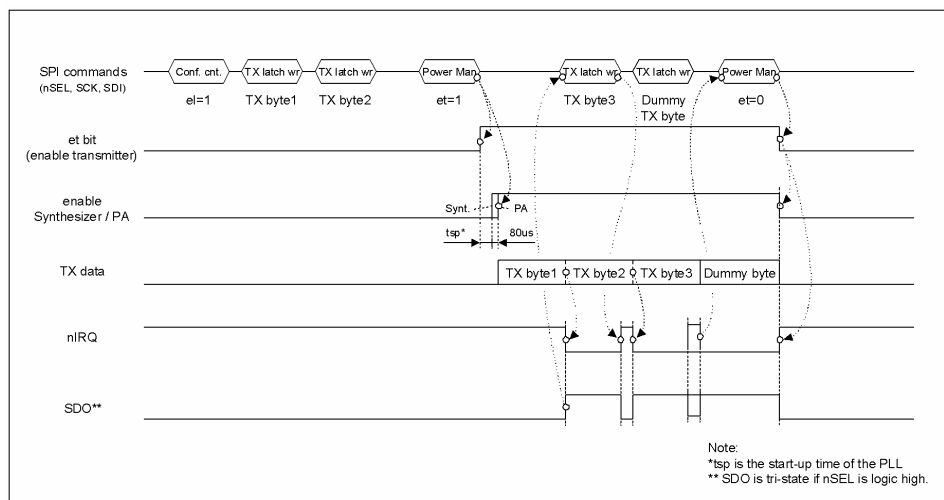

Note: The content of the data registers are initialized by clearing bit *et*.

RX FIFO BUFFERED DATA READ

In this operating mode, incoming data are clocked into a 16 bit FIFO buffer. The receiver starts to fill up the FIFO when the Valid Data Indicator (VDI) bit and the synchron pattern recognition circuit indicates potentially real incoming data. This prevents the FIFO from being filled with noise and overloading the external microcontroller.

Polling Mode:

The nFFS signal selects the buffer directly and its content can be clocked out through pin SDO by SCK. Set the FIFO IT level to 1. In this case, as long as FFIT indicates received bits in the FIFO, the controller may continue to take the bits away. When FFIT goes low, no more bits need to be taken. An SPI read command is also available.

Interrupt Controlled Mode:

The user can define the FIFO level (the number of received bits) which will generate the nFFIT when exceeded. The status bits report the changed FIFO status in this case.

FIFO Read Example with FFIT Polling

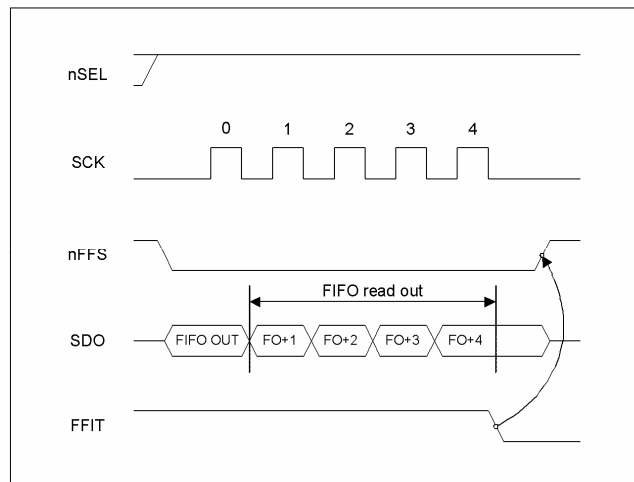

During FIFO access f_{SCK} cannot be higher than $f_{ref} / 4$, where f_{ref} is the crystal oscillator frequency.

CRYSTAL SELECTION GUIDELINES

The crystal oscillator of the RF12 requires a 10 MHz parallel mode crystal. The circuit contains an integrated load capacitor in order to minimize the external component count. The internal load capacitance value is programmable from 8.5 pF to 16 pF in 0.5 pF steps. With appropriate PCB layout, the total load capacitance value can be 10 pF to 20 pF so a variety of crystal types can be used.

When the total load capacitance is not more than 20 pF and a worst case 7 pF shunt capacitance (C_0) value is expected for the crystal, the oscillator is able to start up with any crystal having less than 300 ohms ESR (equivalent series loss resistance). However, lower C_0 and ESR values guarantee faster oscillator startup.

The crystal frequency is used as the reference of the PLL, which generates the local oscillator frequency (f_{LO}). Therefore f_{LO} is directly proportional to the crystal frequency. The accuracy requirements for production tolerance, temperature drift and aging can thus be determined from the maximum

allowable local oscillator frequency error.

Whenever a low frequency error is essential for the application, it is possible to “pull” the crystal to the accurate frequency by changing the load capacitor value. The widest pulling range can be achieved if the nominal required load capacitance of the crystal is in the “midrange”, for example 16 pF. The “pull-ability” of the crystal is defined by its motional capacitance and C_0 .

Maximum XTAL Tolerances Including Temperature and Aging [ppm]

Bit Rate: 2.4kbps	Deviation [+/- kHz]						
	30	45	60	75	90	105	120
315 MHz	25	50	75	100	100	100	100
433 MHz	20	30	50	70	90	100	100
868 MHz	10	20	25	30	40	50	60
915 MHz	10	15	25	30	40	50	50

Bit Rate: 9.6kbps	Deviation [+/- kHz]						
	30	45	60	75	90	105	120
315 MHz	20	50	70	75	100	100	100
433 MHz	15	30	50	70	80	100	100
868 MHz	8	15	25	30	40	50	60
915 MHz	8	15	25	30	40	50	50

Bit Rate: 38.3kbps	Deviation [+/- kHz]						
	30	45	60	75	90	105	120
315 MHz	don't use	7	30	50	75	100	100
433 MHz	don't use	5	20	30	50	75	75
868 MHz	don't use	3	10	20	25	30	40
915 MHz	don't use	3	10	15	25	30	40

RX-TX ALIGNMENT PROCEDURES

RX-TX frequency offset can be caused only by the differences in the actual reference frequency. To minimize these errors it is suggested to use the same crystal type and the same PCB layout for the crystal placement on the RX and TX PCBs.

To verify the possible RX-TX offset it is suggested to measure the CLK output of both chips with a high level of accuracy. Do not measure the output at the XTL pin since the measurement process itself will change the reference frequency. Since the carrier frequencies are derived from the reference frequency, having identical reference frequencies and nominal frequency settings at the TX and RX side there should be no offset if the CLK signals have identical frequencies.

It is possible to monitor the actual RX-TX offset using the AFC status report included in the status byte of the receiver. By reading out the status byte from the receiver the actual measured offset frequency will be reported. In order to get accurate values the AFC has to be disabled during the read by clearing the "en" bit in the AFC Control Command (bit 0).

REFERENCE DESIGNS

Schematic

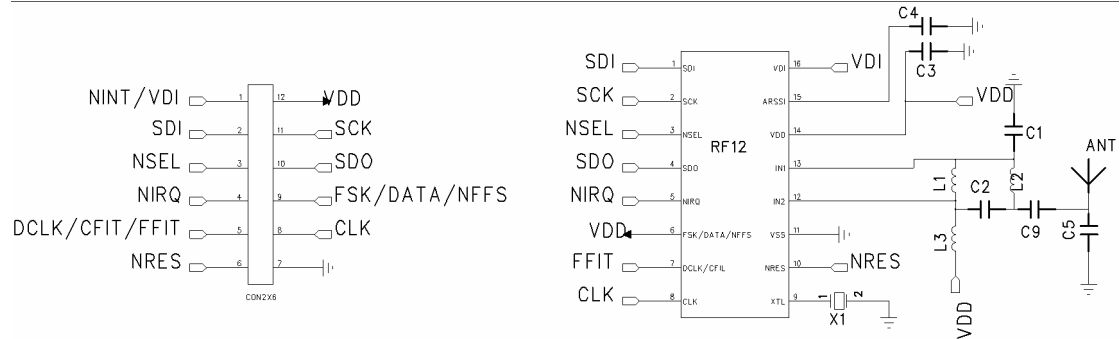

PART	C1	C2	C3	C4	C9	L1	L2	L3	C5
BAND									
315	4.7PF	1.5PF	100nF	4.7nF	68PF	56nH	56nH	220nH	NC
433	4.7PF	1.5PF	100nF	4.7nF	68PF	36nH	43nH	220nH	NC
868	2.7PF	3.9PF	100nF	4.7nF	47PF	18nH	22nH	100nH	NC
915	2.7PF	3.9PF	100nF	4.7nF	47PF	18nH	22nH	100nH	NC

PCB layout

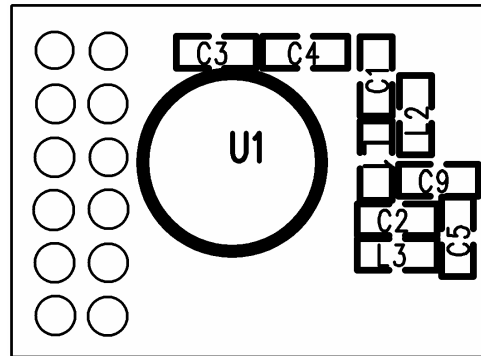
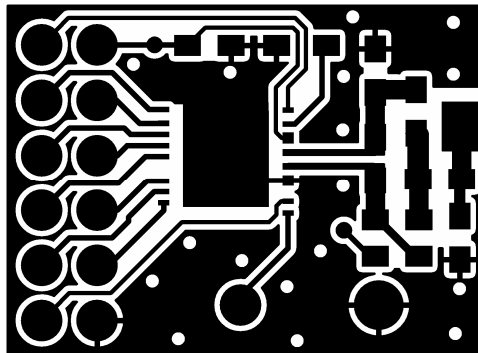

Top view

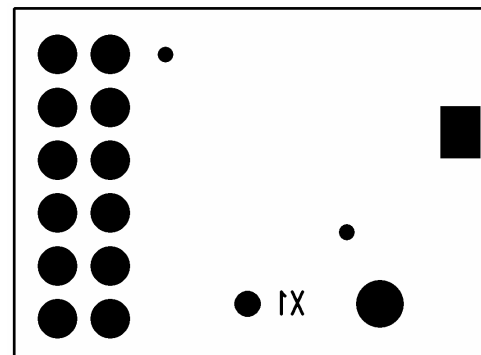
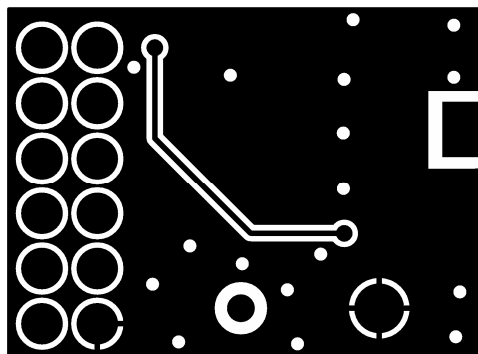

Bottom view

SGS Reports

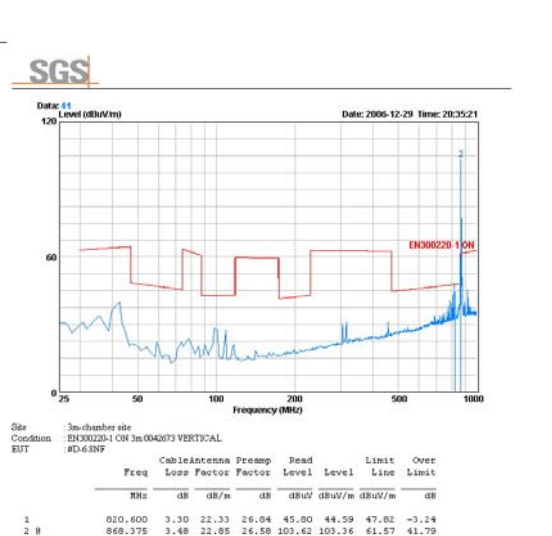
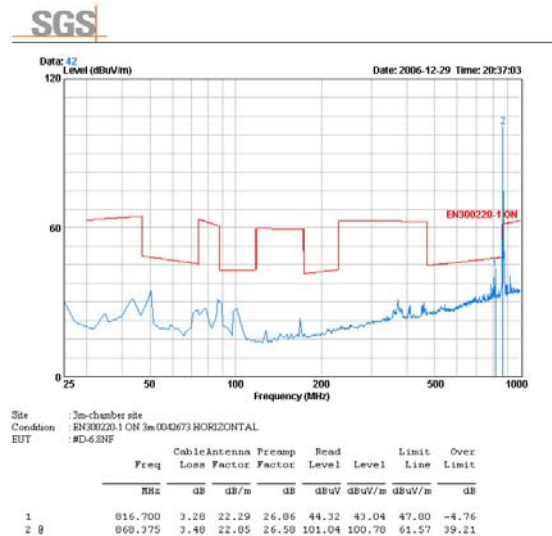
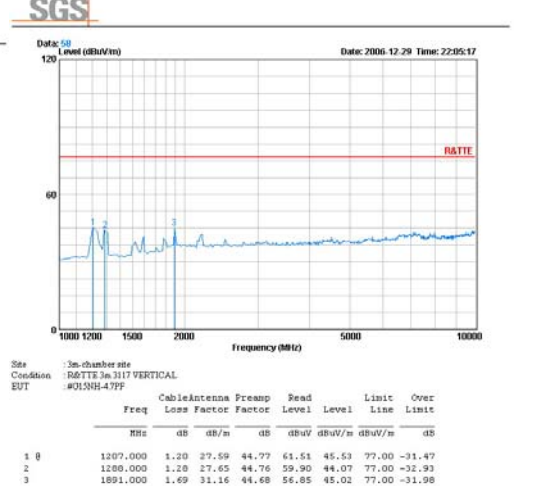
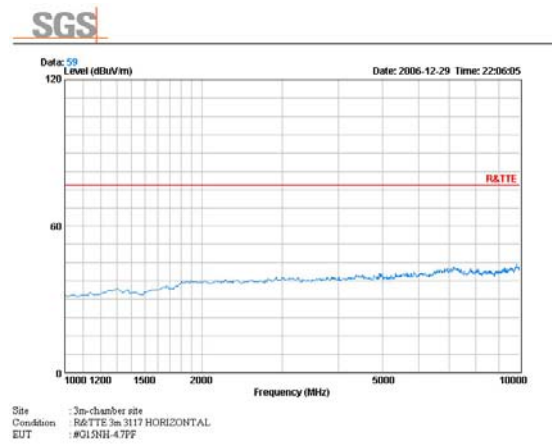
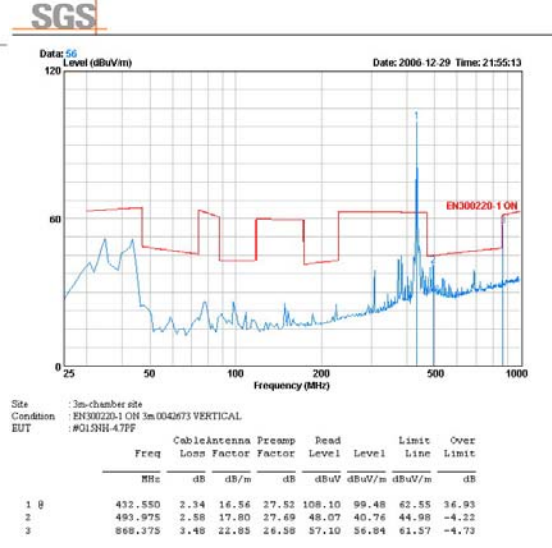
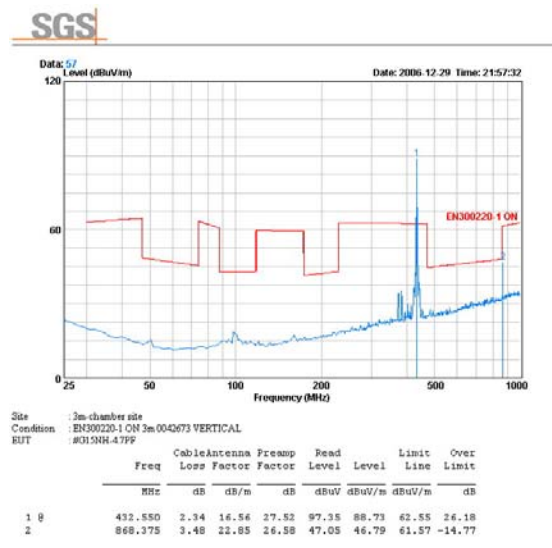

SGS

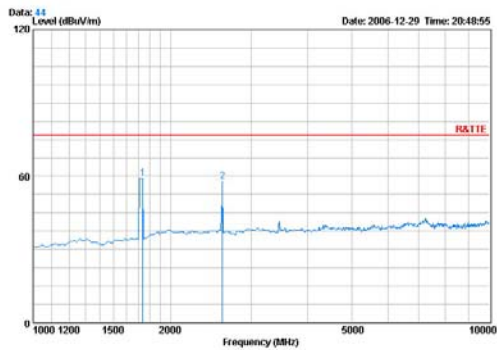

Site : 3m-chamber site
 Condition : R&TTE 3m 3117 HORIZONTAL
 EUT : #D-63NF

	Freq	Cable	Antenna	Preamp	Read	Limit	Over
	MHz	Loss	Factor	Factor	Level	Line	Limit
	MHz	dB	dB/m	dB	dBuV	dBuV/m	dBuV/m
1	1738.000	1.60	29.84	44.70	72.33	59.18	77.00 -17.83
2	2602.000	2.04	32.54	44.80	67.95	57.73	77.00 -19.27

SGS

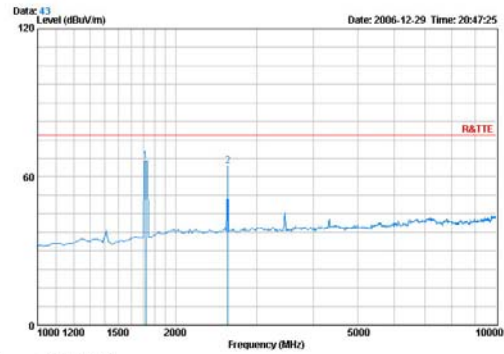

Site : 3m-chamber site
 Condition : R&TTE 3m 3117 VERTICAL
 EUT : #D-63NF

	Freq	Cable	Antenna	Preamp	Read	Limit	Over
	MHz	Loss	Factor	Factor	Level	Line	Limit
	MHz	dB	dB/m	dB	dBuV	dBuV/m	dBuV/m
1	1720.000	1.59	29.82	44.70	79.69	66.40	77.00 -10.60
2	2602.000	2.04	32.54	44.80	74.74	64.52	77.00 -12.48

SGS

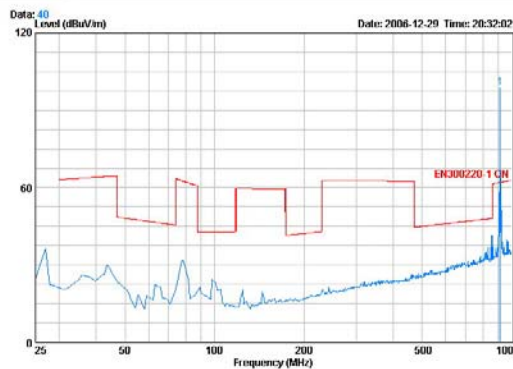

Site : 3m-chamber site
 Condition : EN300220-1 CH 3m 0042673 HORIZONTAL
 EUT : #F-63NF

	Freq	Cable	Antenna	Preamp	Read	Limit	Over
	MHz	Loss	Factor	Factor	Level	Line	Limit
	MHz	dB	dB/m	dB	dBuV	dBuV/m	dBuV/m
1	914.200	3.62	23.26	26.43	90.20	90.73	62.05 36.60

SGS

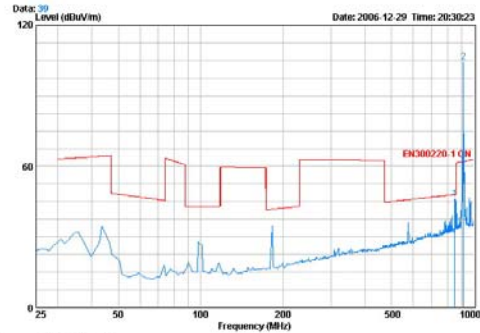

Site : 3m-chamber site
 Condition : EN300220-1 CH 3m 0042673 VERTICAL
 EUT : #F-63NF

	Freq	Cable	Antenna	Preamp	Read	Limit	Over
	MHz	Loss	Factor	Factor	Level	Line	Limit
	MHz	dB	dB/m	dB	dBuV	dBuV/m	dBuV/m
1	851.000	3.42	22.40	26.67	46.75	45.98	48.03 -2.06
2	914.200	3.62	23.26	26.43	103.82	104.27	62.05 42.22

SGS

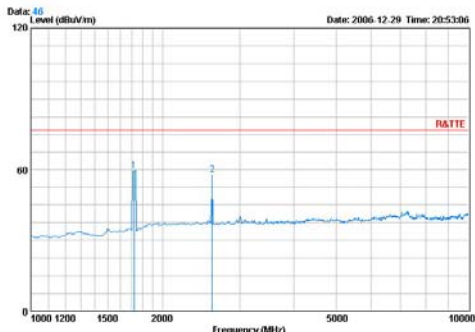

Site : 3m-chamber site
 Condition : R&TTE 3m 3117 HORIZONTAL
 EUT : #F-63NF

	Freq	Cable	Antenna	Preamp	Read	Limit	Over
	MHz	Loss	Factor	Factor	Level	Line	Limit
	MHz	dB	dB/m	dB	dBuV	dBuV/m	dBuV/m
1	1720.000	1.59	29.82	44.70	72.93	59.63	77.00 -17.37
2	2602.000	2.04	32.54	44.80	67.94	57.72	77.00 -19.28

SGS

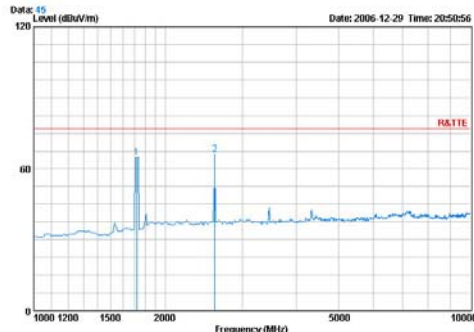

Site : 3m-chamber site
 Condition : R&TTE 3m 3117 VERTICAL
 EUT : #F-63NF

	Freq	Cable	Antenna	Preamp	Read	Limit	Over
	MHz	Loss	Factor	Factor	Level	Line	Limit
	MHz	dB	dB/m	dB	dBuV	dBuV/m	dBuV/m
1	1720.000	1.59	29.82	44.70	76.10	64.80	77.00 -12.20
2	2602.000	2.04	32.54	44.80	76.30	66.00	77.00 -10.92

RF12 BONDING DIAGRAM

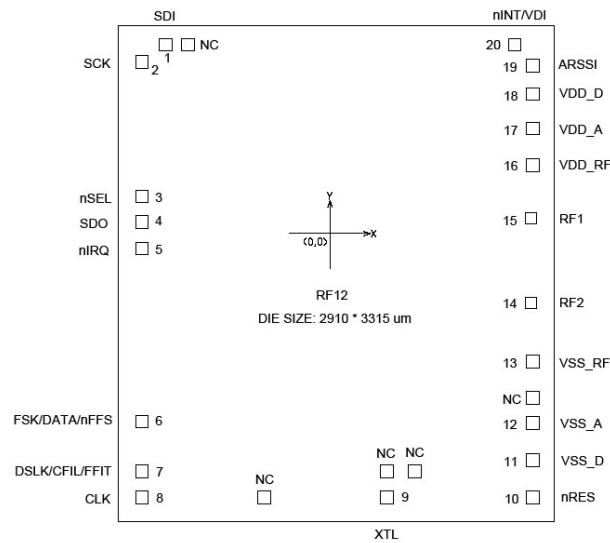

Pad Opening: 85um square, except 76um octagon pads (AN1, AN2)
Die Size: 2910 X 3315 um

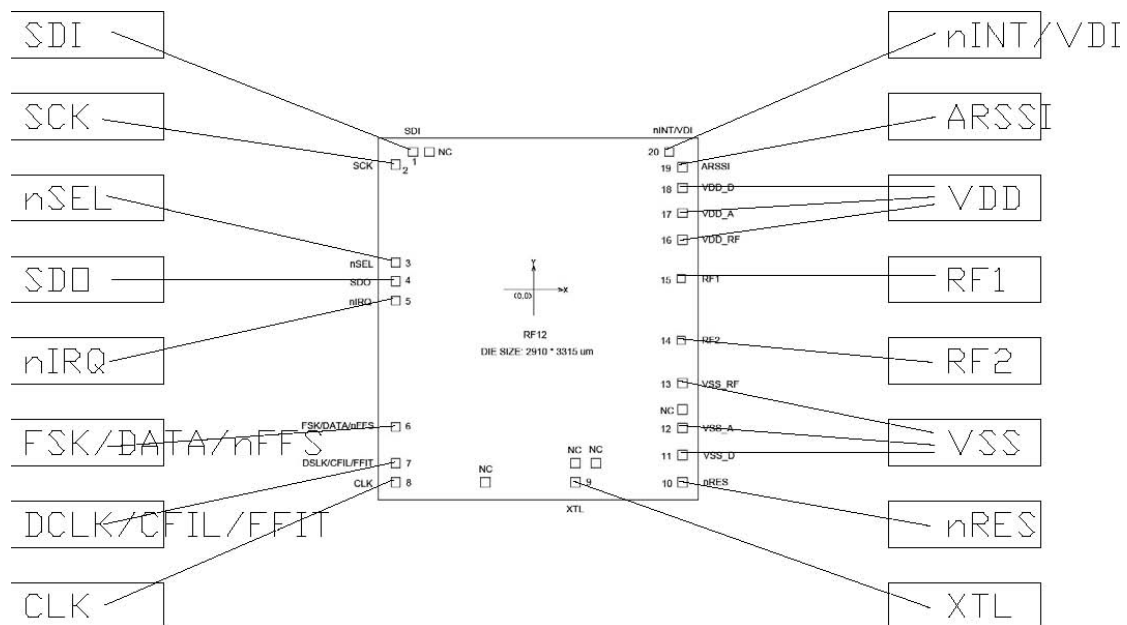

HOPE MICROELECTRONICS CO.,LTD

Add:4/F, Block B3, East Industrial Area,
Huaqiaocheng, Shenzhen, Guangdong,
China

Tel: 86-755-86096602

Fax: 86-755-86096587

Email: sales@hoperf.com

Website: <http://www.hoperf.com>

<http://www.hoperf.cn>

<http://hoperf.en.alibaba.com>

This document may contain preliminary information and is subject to change by Hope Microelectronics without notice. Hope Microelectronics assumes no responsibility or liability for any use of the information contained herein. Nothing in this document shall operate as an express or implied license or indemnity under the intellectual property rights of Hope Microelectronics or third parties. The products described in this document are not intended for use in implantation or other direct life support applications where malfunction may result in the direct physical harm or injury to persons. NO WARRANTIES OF ANY KIND, INCLUDING, BUT NOT LIMITED TO, THE IMPLIED WARRANTIES OF MERCHANTABILITY OR FITNESS FOR A PARTICULAR PURPOSE, ARE OFFERED IN THIS DOCUMENT.

©2006, HOPE MICROELECTRONICS CO.,LTD. All rights reserved.