

Stable Filament Supply

Dr Alexander Voigt

Valves are enjoying increasing popularity in audio systems. With the European 'E' series of valves, such as the ECC83 (12AX7) and EL84 (6BQ5), the filament voltage is 6.3 V. Depending on how the circuit is wired, the ECC 81–83 series of twin triodes can also be used with a filament voltage of 12.6 V. In earlier times, the filament voltage was usually taken directly from a separate transformer winding, which (in part) was responsible for the well known 'valve hum'.

With regard to the signal path, current valve circuits have hardly experienced any fundamental changes. In high-quality valve equipment, though, it is relatively common to find a stabilised anode supply. Mains hum can have a measurable and audible effect on input stages whose filaments are heated by an ac voltage. The remedy described here is a stabilised and precisely regulated dc filament voltage. The slow rise of the filament voltage after switching on is also beneficial. The exact setting of the voltage level and the soft start have a positive effect on the useful life of the valves.

Figure 1 shows a voltage regulator meeting these requirements that is built from discrete components. The two sets of component values are for a voltage of 6.3 V (upper) and 12.6 V (lower). Thanks to the fact that the supply works with a constant load, it can do without special protective circuits and the additional complexity of optimum regulation characteristics for dynamic loads.

The circuit in Figure 1 consists of a power MOSFET configured as a series-pass regulator and a conventional control amplifier. Zener diode (D5) sets the reference potential. A constant voltage is thus present at the emitter of the BC547 control amplifier (T3). The current through D5 is set to approximately 4–5 mA by series resistor R5.

The output voltage U_o (the controlled variable) acts on the base of the control amplifier (T3) via voltage divider R6/R7. If the output voltage drops, the collector current of T3 also decreases, and with it the voltage drop across load resistors R1 and R2. The voltage on the gate of the MOSFET thus increases. This closes the control loop. The values of the resistors forming the voltage divider are chosen for

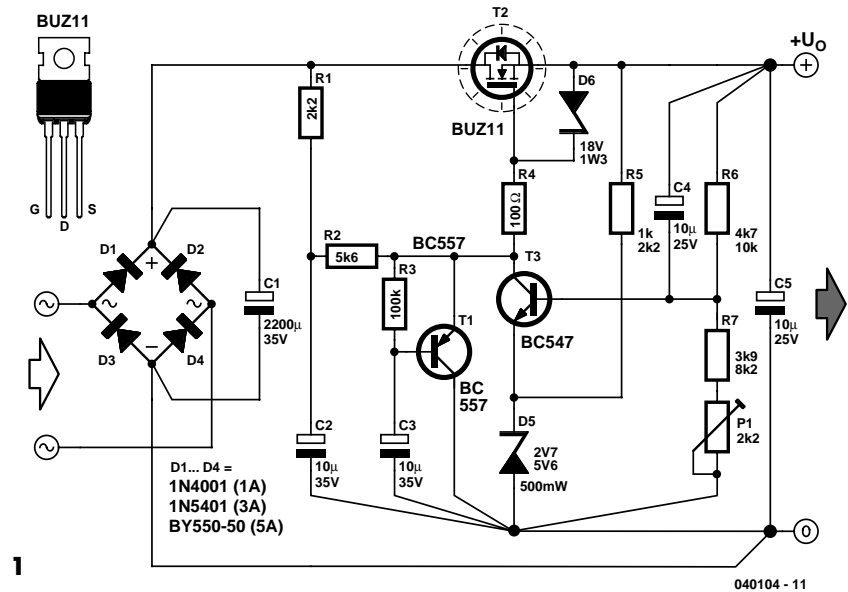

1

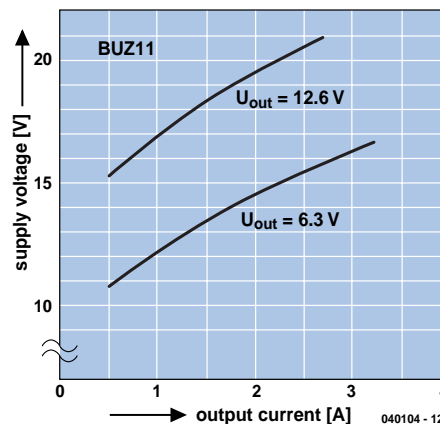

2

the usual tolerances of Zener diodes, but they must be adjusted if the diode is out of spec (which can happen).

The load resistance of the control amplifier is divided between R1 and R2. The current through the load resistance and the collector current of T3 are practically the same, since the MOSFET draws almost no gate current. Filter capacitor C2 is connected to the junction of R1 and R2 to reduce residual hum. Electrolytic capacitor C4 and power supply filter capacitor C1 serve the same purpose. The hum voltage also depends on the magnitude of the load current.

The voltage drop over the series-pass regulator is nearly the same for an output voltage of 6.3 V or 12.6 V. With a BUZ11 and a load of 1 A at 6.3 V, for instance, the average voltage across the source-drain channel is approximately 7 V. The power dissipation of 7 W requires a corresponding heat sink.

The slow rise of the output voltage is due to the presence of timing network R3/C3 and T1. When power is switched on, T1 holds the gate of the MOSFET at nearly ground level. As C3 charges, T1 conducts increasingly less current, so ultimately only the control transistor affects the gate voltage.

The mains transformer must be selected according to the required load current. The required value of the input voltage can be read from the chart. The transformer should have a power rating at least 30 % greater than what is necessary based on the calculated load dissipation. Where possible, preference should be given to a filament voltage of 12.6 V. When twin triodes in the ECC81–83 series are used, for example, the power dissipation in the series pass transistor is lower with a voltage of 12.6 V.

(040104-1)