

**Sony KV-C2949D**  
**Chassis AE-1C**  
 (Strona 1/4)

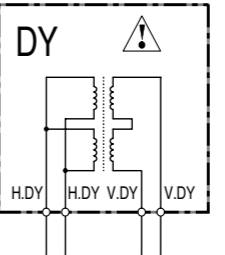

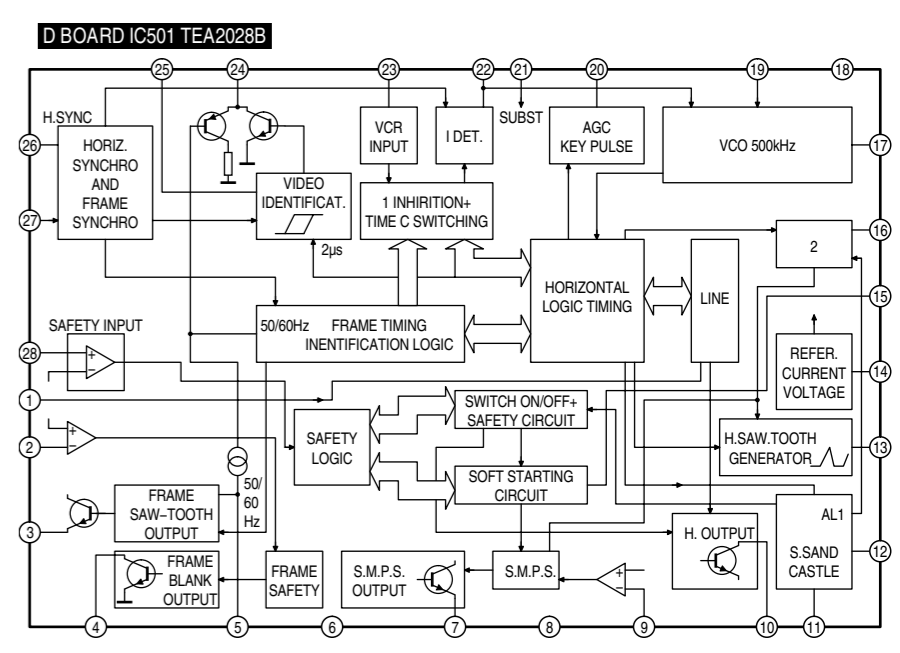
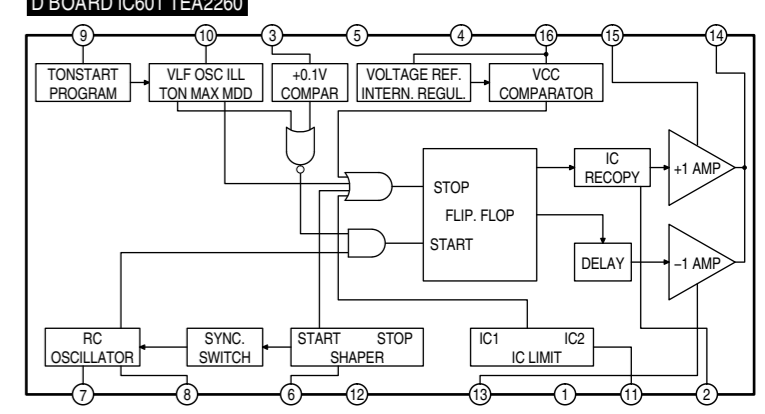
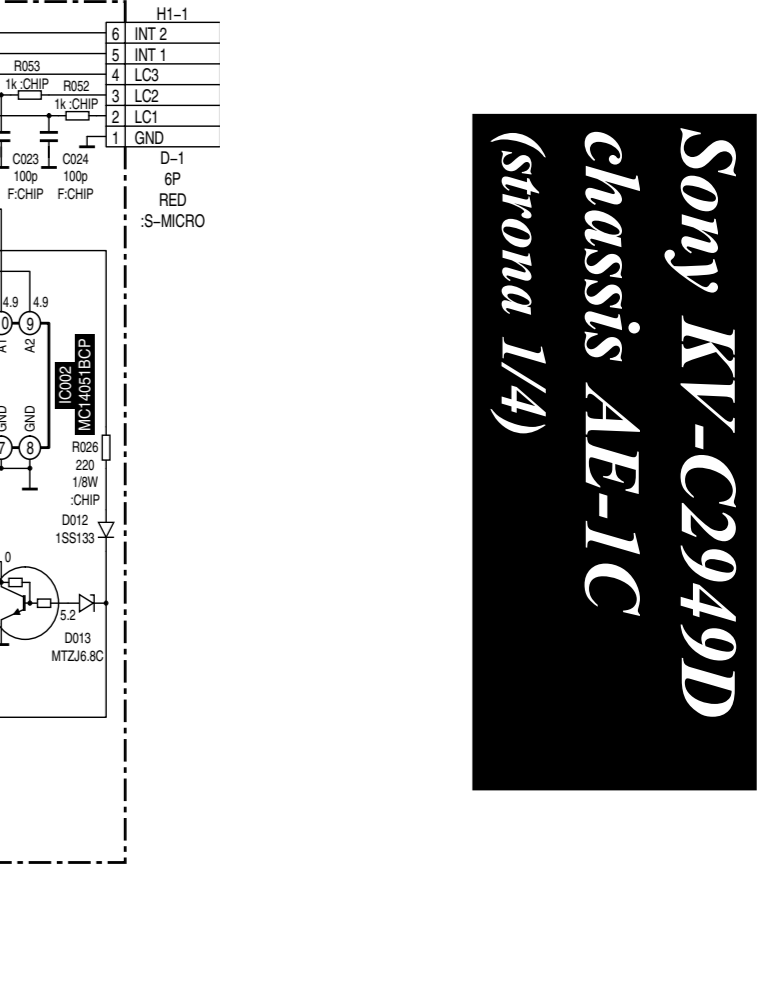
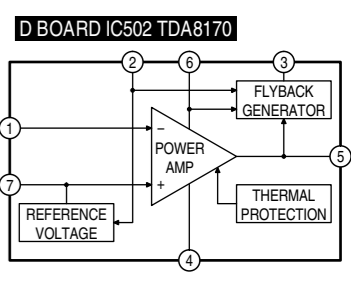
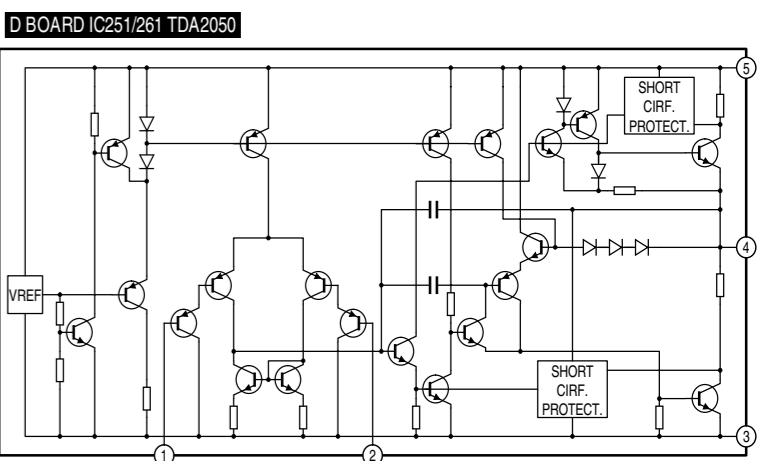
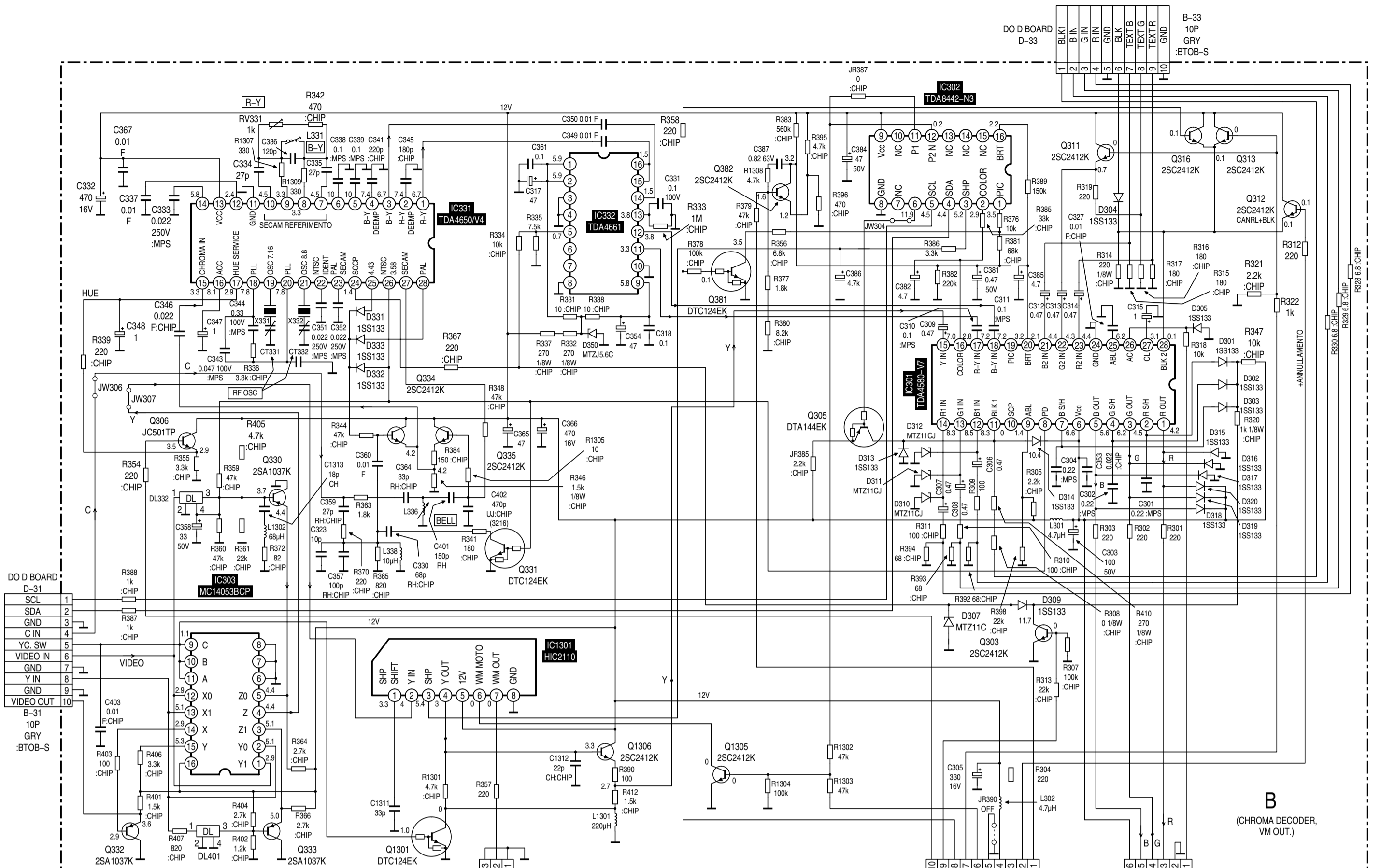

	PAL	SECAM	NTSC58	NTSC43
IC301	0.1	0.1	5.8	0.1
IC331	6.7	6.8	5.1	6.5
IC332	3.1	3.6	3.1	2.8
IC302	3.0	3.5	2.9	2.7
IC303	5.6	5.6	7.1	7.2
IC1301	7.5	7.0	5.6	5.6
Q301	0.1	0.1	0.1	5.8
Q302	0.1	0.1	5.8	0.1
Q303	0.1	5.8	0.1	0.1
Q304	5.9	0.1	0.1	0.1
Q311 (B)	0.1	0.1	5.8	0.1
Q312 (C)	0.3	0.4	0	0.8
Q333 (B)	4.4	4.4	4.4	4.4
Q334 (B)	4.9	0.1	4.8	4.8
Q335 (B)	0.1	4.8	0.1	0.1

**Sony KV-C2949D**  
**chassis AE-1C**  
 (strona 2/4)

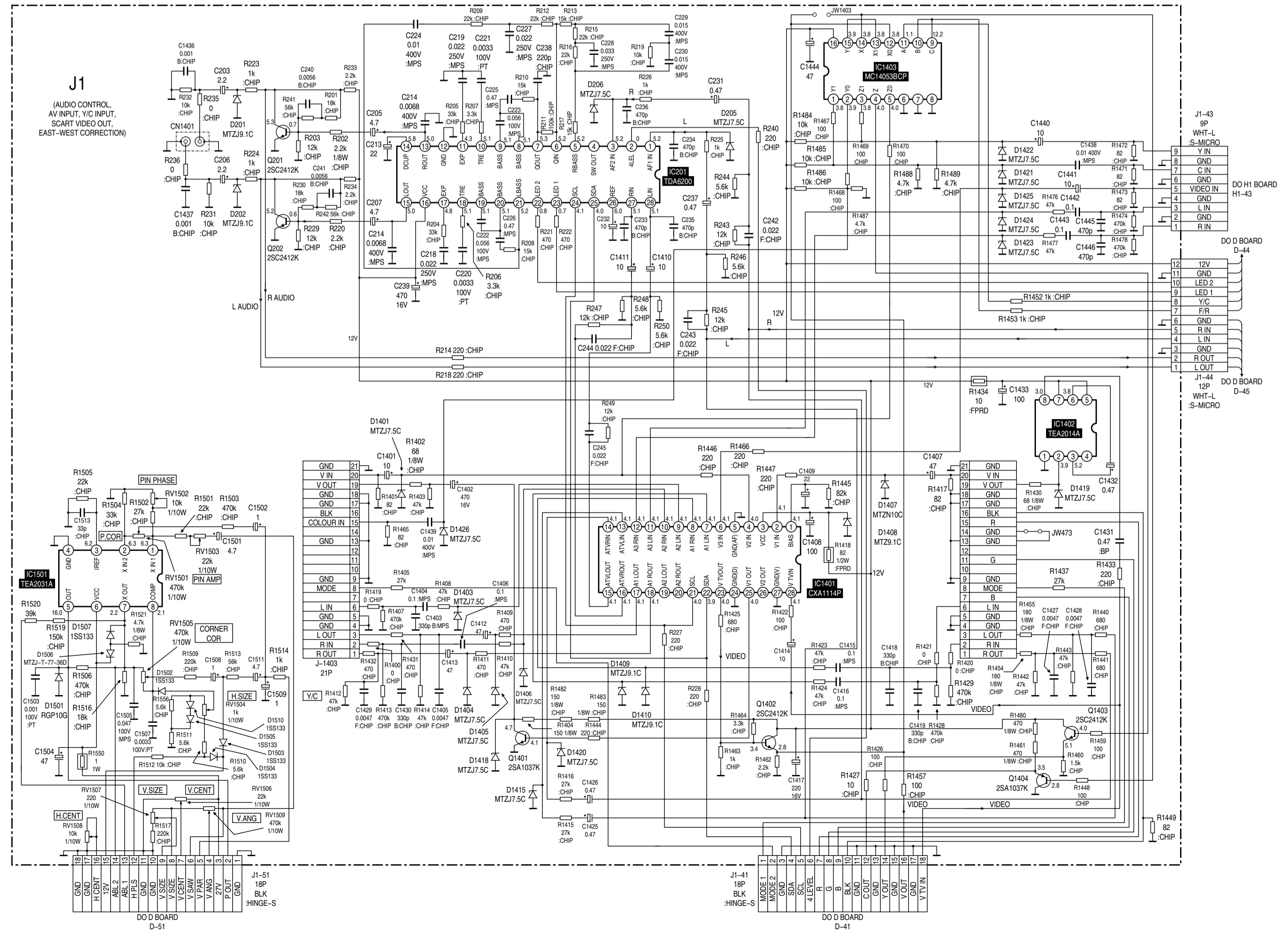

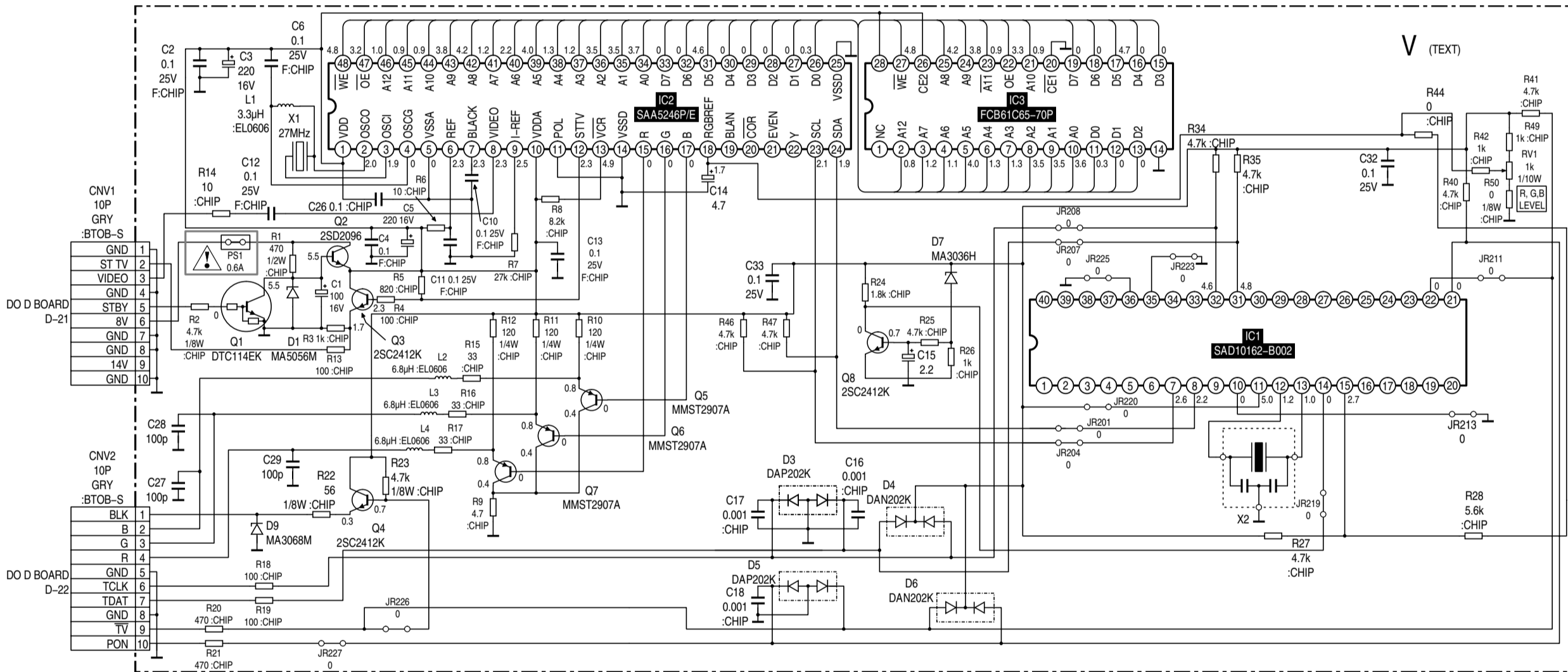
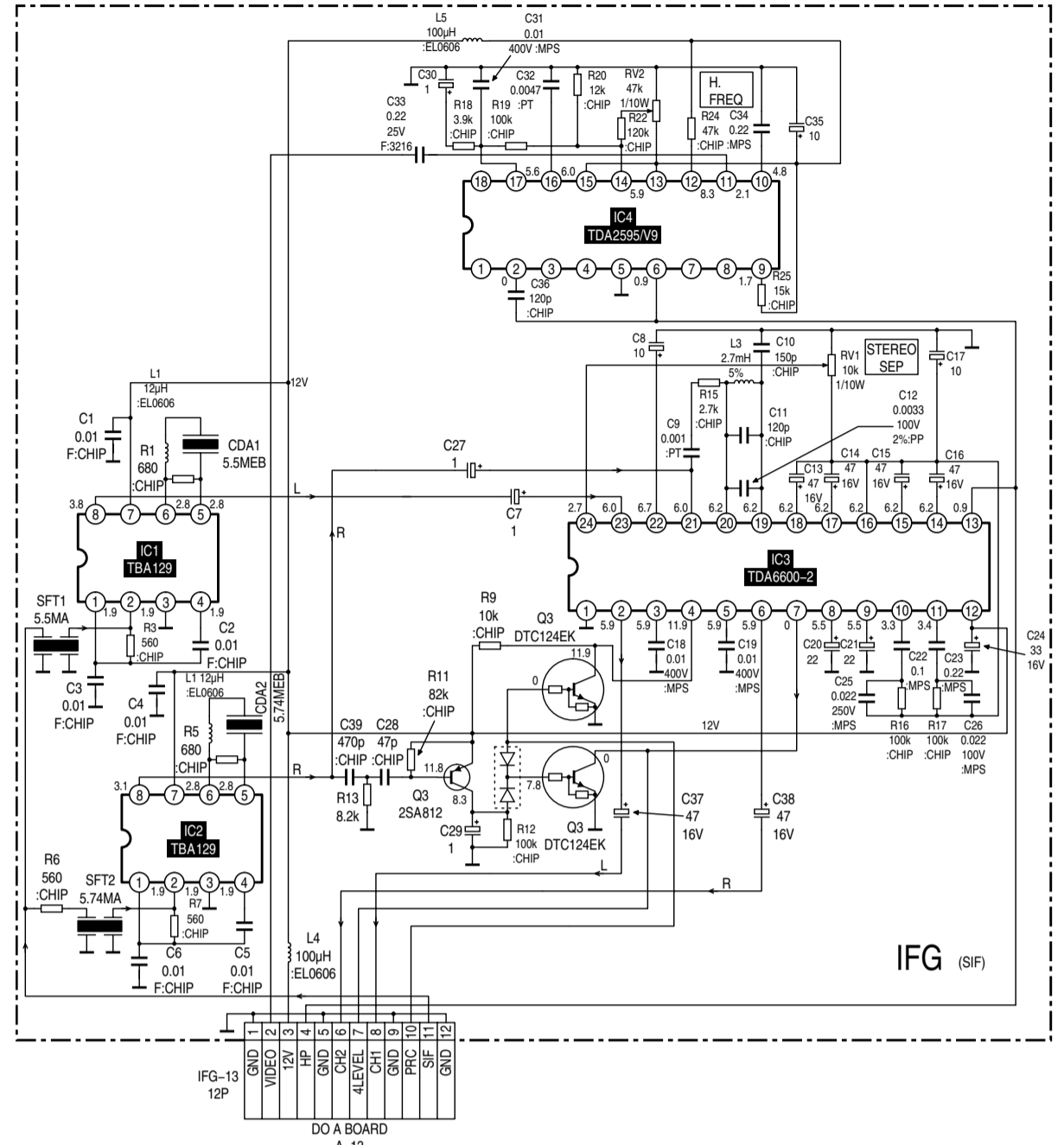
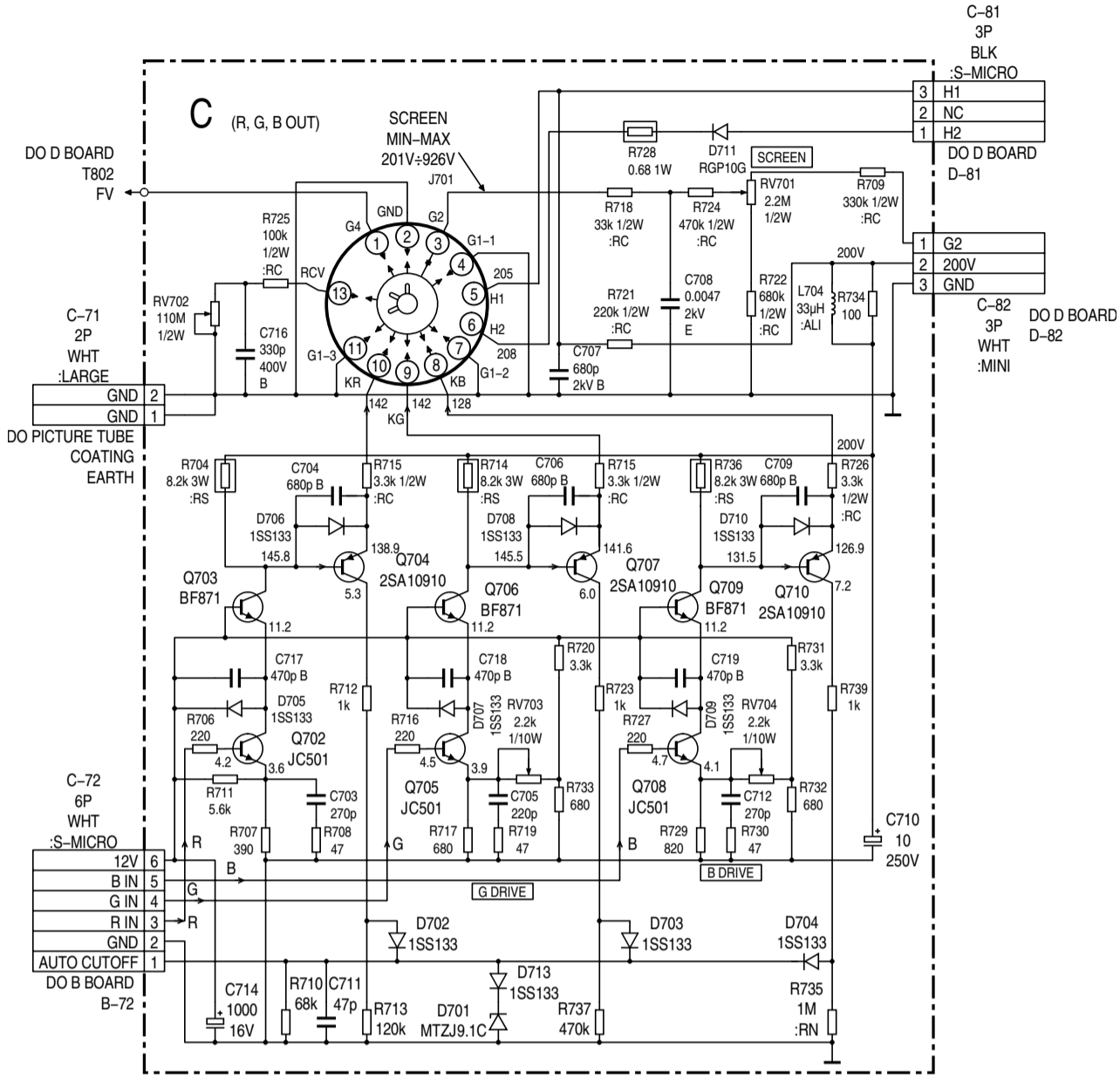
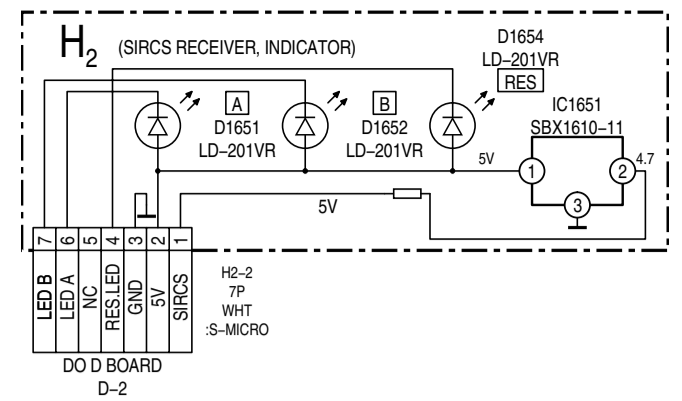
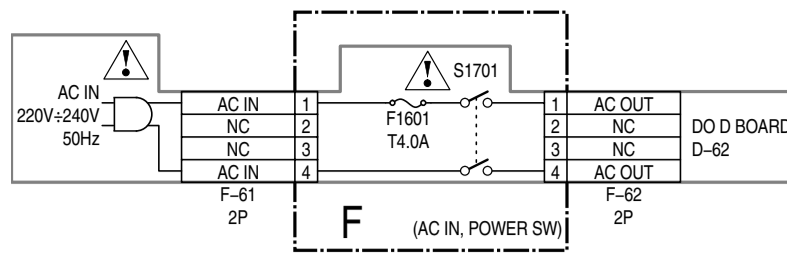
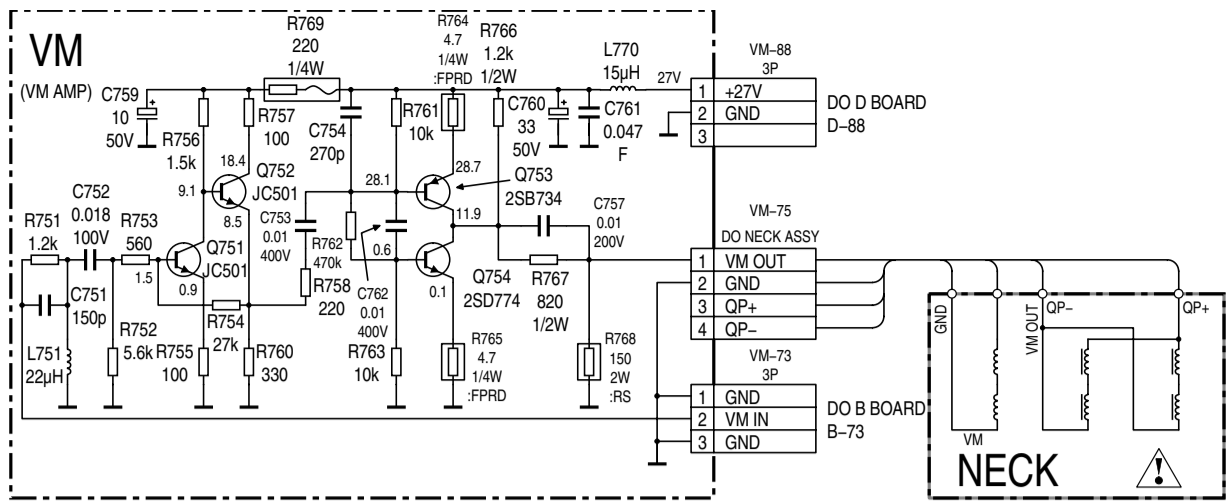

**Sony KV-C2949D**  
**Chassis AE-1C**  
 (strona 3/4)

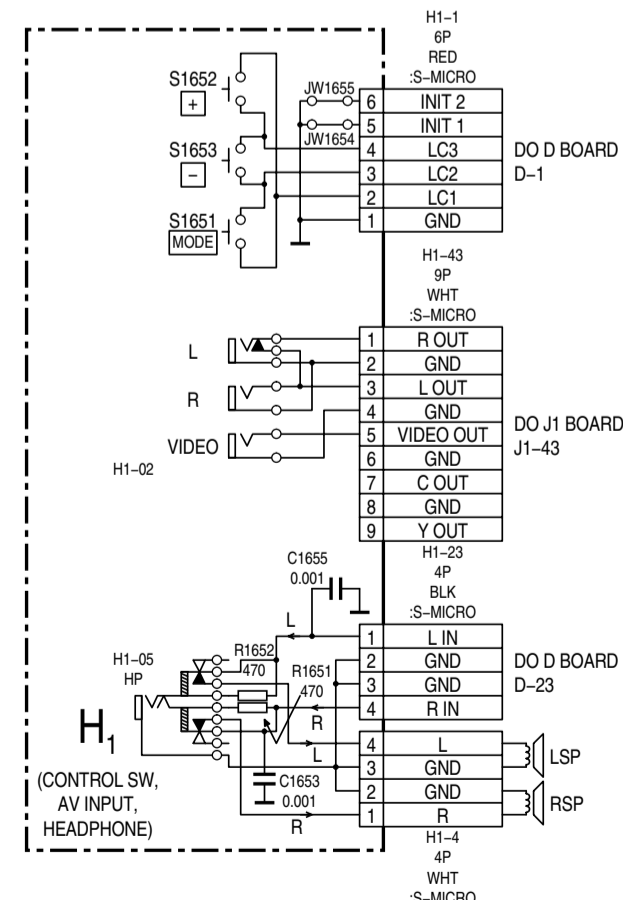
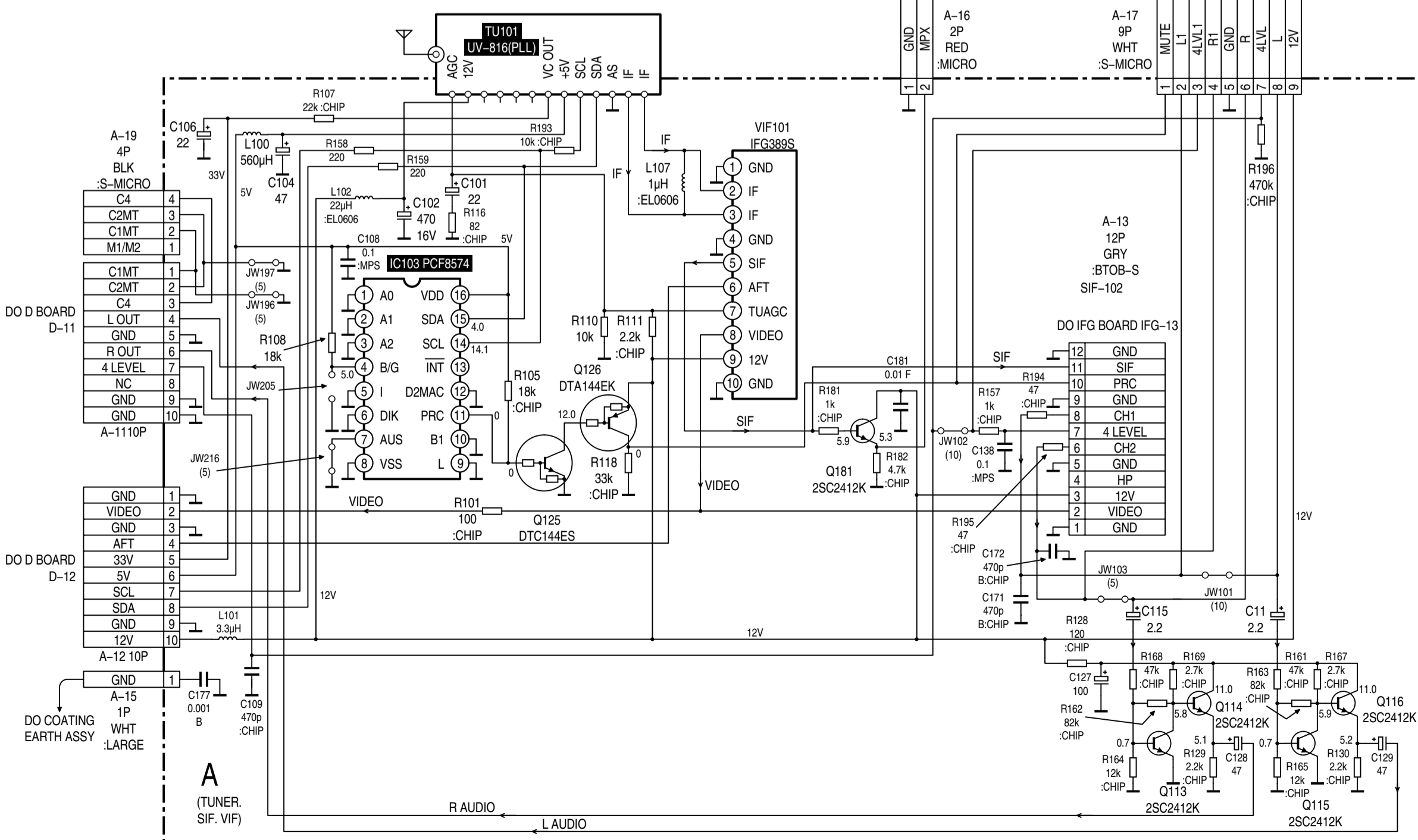

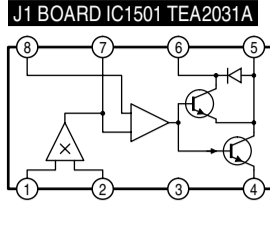
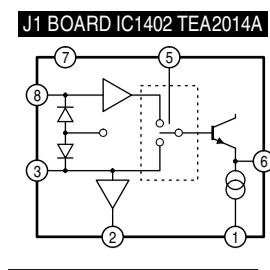
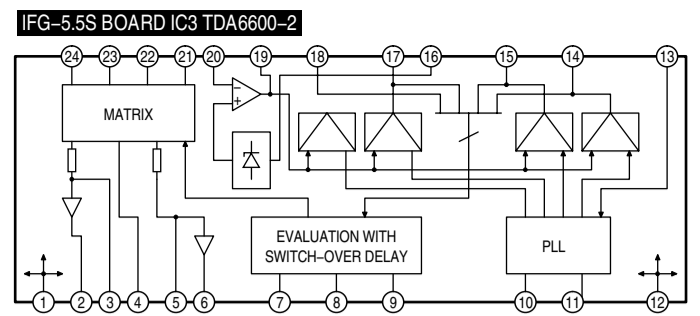
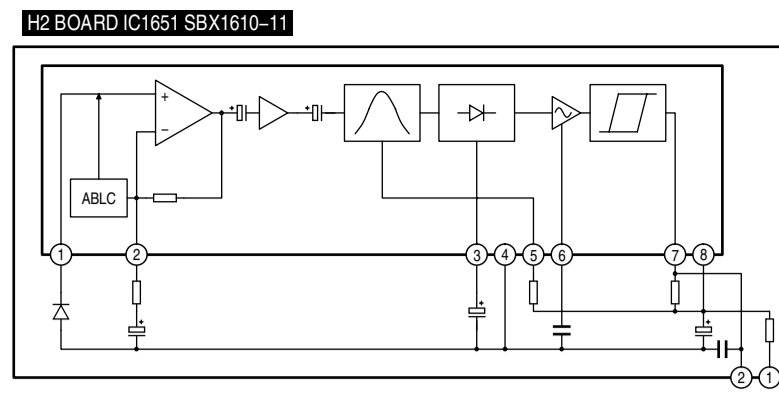
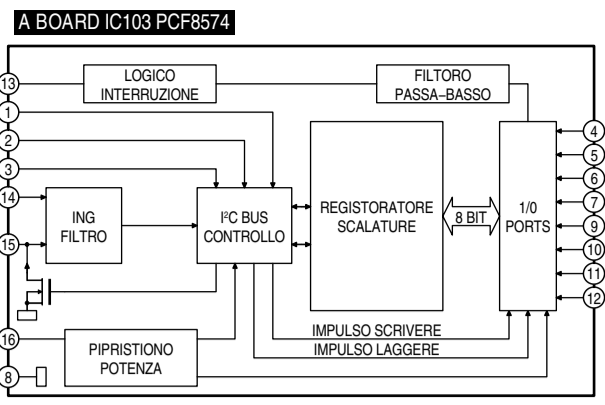

IFG-5.5S BOARD IC4 TDA2595/V9

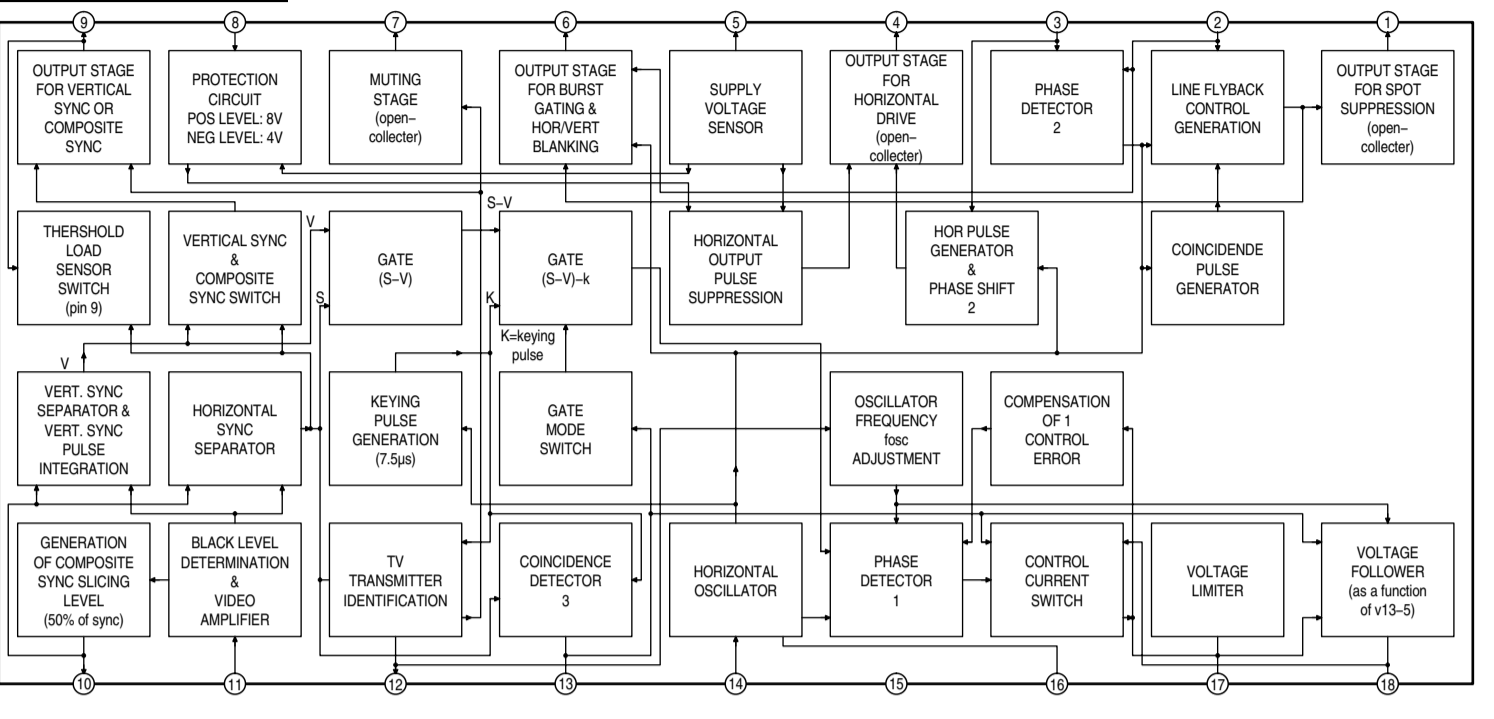

B BOARD IC302 TDA8442-N3

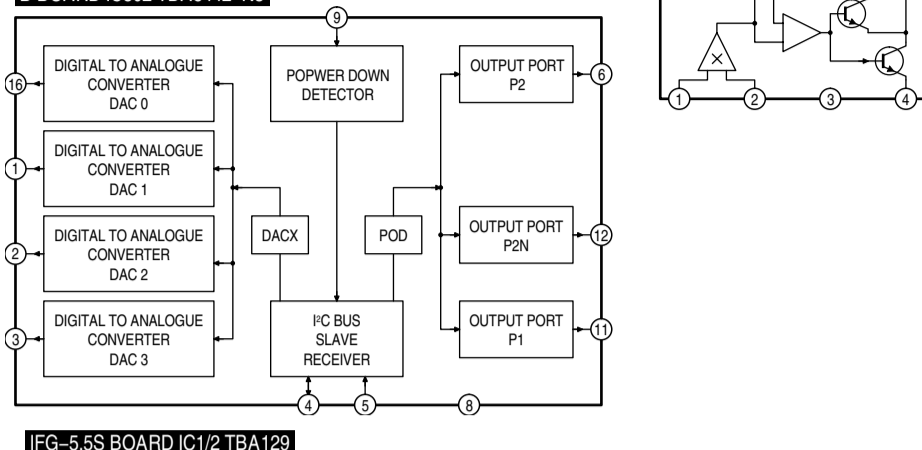

IFG-5.5S BOARD IC12 TBA129

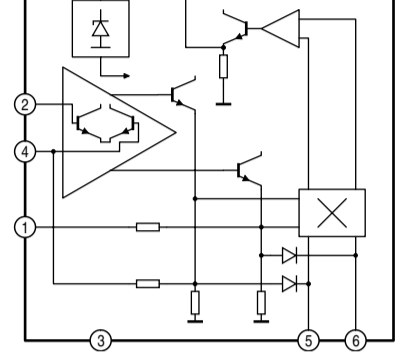

B BOARD IC303 MC14053BCP

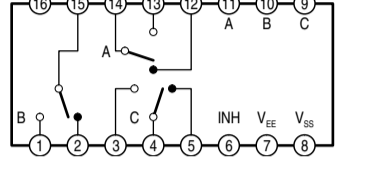

J1 BOARD IC1403 MC14053BCP

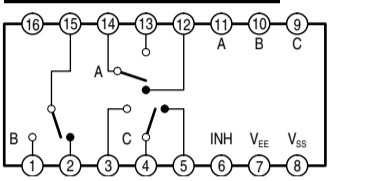

B BOARD IC301 TDA4580-V7

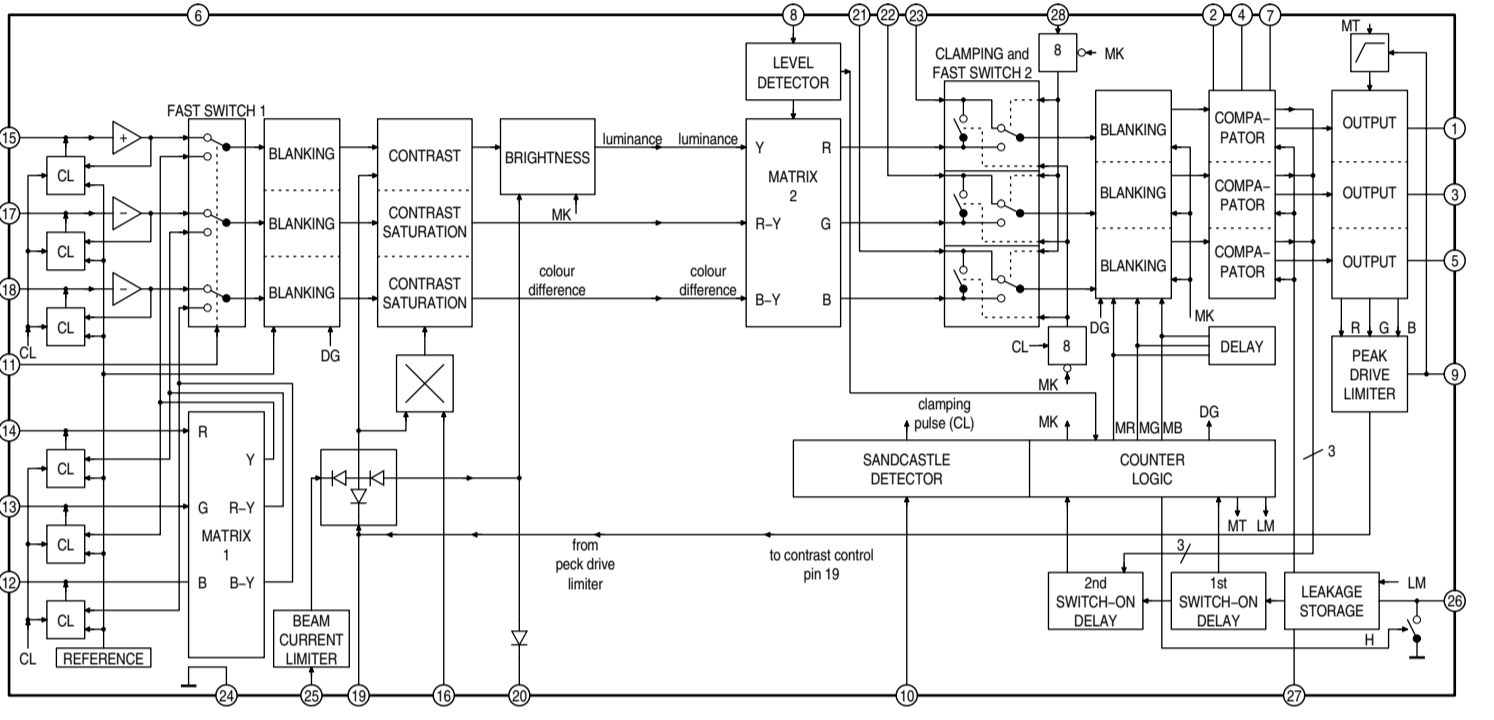

B BOARD IC331 TDA4650/V4

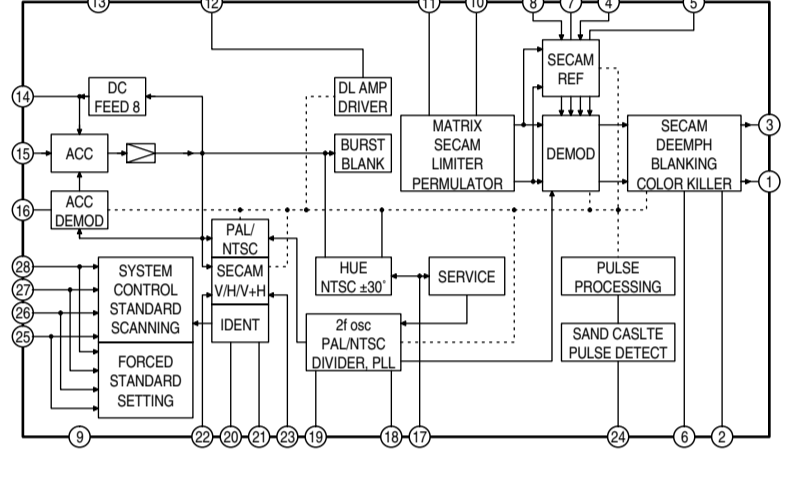

J1 BOARD IC201 TDA6200

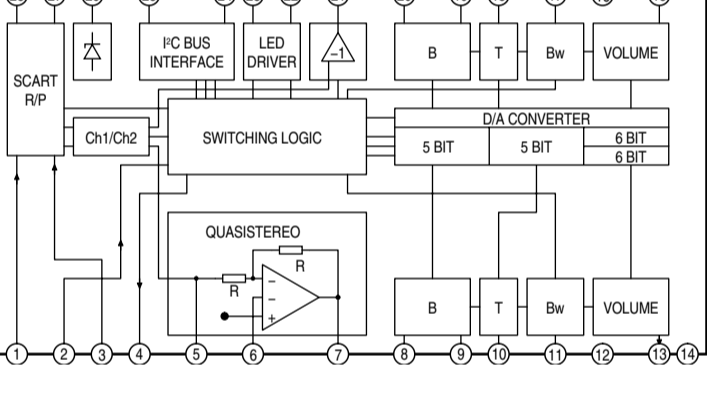

Q702	JC501	R DRIVE
Q703	BF871	R OUT
Q704	2SA10910	ACO MEASURING
Q705	JC501	G DRIVE
Q706	BF871	G OUT
Q707	2SA10910	ACO MEASURING
Q708	JC501	B DRIVE
Q709	BF871	B OUT
Q710	2SA10910	ACO MEASURING
D701	MTZJ9.1C	PROTECT
D702	1SS133	PROTECT
D703	1SS133	PROTECT
D704	1SS133	PROTECT
D705	1SS133	PROTECT
D706	1SS133	PROTECT
D707	1SS133	PROTECT
D708	1SS133	PROTECT
D709	1SS133	PROTECT
D710	1SS133	PROTECT
D711	RGP10G	HEATING VOLTAGE REC
D713	1SS133	PROTECT

IC1	SDA20162-B002	MICRO-CONT
IC2	SAAS246PIE	IVT
IC3	FCB61C65-70P	STATIC-RAM
Q1	DTC114EK	STAD BY
Q2	2SD2096	5V REG
Q3	2SC2412K	SYNC BUFFER
Q4	2SC2412K	BLK OUT
Q5	MMST2907A	B OUT
Q6	MMST2907A	G OUT
Q7	MMST2907A	R OUT
Q8	2SC2412K	RESET
D1	MA3056M	5V REG
D3	DAP202K	PROTEC
D4	DAN202K	PROTEC
D5	DAP202K	PROTEC
D6	DAN202K	PROTEC
D7	MA3036H	PROTEC
D9	MA3068M	PROTEC

IC201	TDA6200	AUDIO CONTROL
IC1401	CXA1114P	AV SW
IC1402	TEA2014A	SCART VIDEO OUT
IC1403	MC14053BCP	COMPOSITE Y/C SW
IC1501	TEA2031A	EAST-WEST CORRECTION
Q201	2SC2412K	AUDIO R BUFF
Q202	2SC2412K	AUDIO L BUFF
Q1401	2SA1037K	VIDEO OUT
Q1402	2SC2412K	VIDEO OUT BUFF
Q1403	2SC2412K	Y OUT BUFF
Q1404	2SC2412K	C OUT BUFF
D201	MTZJ9.1C	PROTECT
D202	MTZJ9.1C	PROTECT
D205	MTZJ7.5C	PROTECT
D206	MTZJ7.5C	PROTECT
D1401	MTZJ7.5C	PROTECT
D1403	MTZJ7.5C	PROTECT
D1404	MTZJ7.5C	PROTECT
D1405	MTZJ7.5C	PROTECT
D1406	MTZJ7.5C	PROTECT
D1407	MTZJ7.5C	PROTECT
D1408	MTZJ9.1C	REG
D1409	MTZJ9.1C	PROTECT
D1410	MTZJ9.1C	PROTECT
D1415	MTZJ7.5C	PROTECT
D1418	MTZJ7.5C	PROTECT
D1419	MTZJ7.5C	PROTECT
D1420	MTZJ7.5C	PROTECT
D1421	MTZJ7.5C	PROTECT
D1422	MTZJ7.5C	PROTECT
D1423	MTZJ7.5C	PROTECT
D1424	MTZJ7.5C	PROTECT
D1425	MTZJ7.5C	PROTECT
D1426	MTZJ7.5C	PROTECT
D1501	RGP10G	PROTECT
D1502	1SS133	DECOUPLING H SIZE
D1503	1SS133	CLIPPING V PARABORA
D1504	1SS133	CLIPPING H PULSE
D1505	1SS133	REG
D1506	MTZJ36D	PROTECT
D1507	1SS133	PROTECT
D1510	1SS133	REG

IC301	TDA4580-V7	VIDEO PROCESSOR
IC302	TDA8442-N3	D/A CONVERTER I'C BUS
IC303	MC14053BCP	Y/C COMP SW
IC331	TDA4650	COLOR PROCESSOR
IC332	TDA4661	14-DELAY
IC1301	HIC2110	SHARPNESS CONTROL
Q303	2SC2412K	STBY SW
Q305	DTA144EK	ANTI PRIORITY SCART
Q306	JC501	VIDEO BUF (HUE)
Q311	2SC2412K	ON SCREEN DISPLAY SW
Q312	2SC2412K	CANRL+BLK
Q313	2SC2412K	ON SCREEN DISPLAY
Q316	2SC2412K	FAS PICTURE MUTE SW
Q330	2SA1037K	VIDEO AMP
Q331	DTC124EK	NTSC SW
Q332	2SA1037K	VIDEO BUFF
Q333	2SA1037K	Y AMP
Q334	2SC2412K	PAL/NTSC SW
Q335	2SC2412K	SECAM SW
Q381	DTC124EK	MUTE
Q382	2SC2412K	ABL
Q1301	DTC124EK	Y BUFF
Q1305	2SC2412K	Y OUT
Q1306	2SC2412K	Y OUT
D301	1SS133	ACO AT STBY
D302	1SS133	ACO AT STBY
D303	1SS133	ACO AT STBY
D304	1SS133	DECOUPLING BLK
D305	1SS133	PROT
D307	MTZ11C	PROT
D309	1SS133	PROT
D310	MTZ11C	PROT
D311	MTZ11C	PROT
D312	MTZ11C	PROT
D313	1SS133	PROT
D314	1SS133	PROT
D315	1SS133	PROT
D316	1SS133	PROT
D317	1SS133	PROT
D318	1SS133	PROT
D319	1SS133	PROT
D320	1SS133	PROT
D331	1SS133	SECAM SW
D332	1SS133	SECAM SW
D333	1SS133	SECAM SW
D350	MTZJ5.6C	PROT

IC001	SDA20560-A012	TUNING CTL
IC002	MC14051BCP	ON SCREEN DISPLAY
IC003	BA4558	AFT COMPARTOR
IC005	SDA2546	MY MEMORY
IC251	TDA2050	AUDIO OUT (L)
IC261	TDA2050	AUDIO OUT (R)
IC501	TEA2028B	DEFLECTION PROCESSOR
IC502	TDA8170	V OUT
IC601	TEA2260	PRIMARY SMRS CTL
IC604	TEA7605	+5V REG
IC608	MC7812CT	+12V REG
Q001	DTC144EK	50/60HZ SW
Q002	DTC144EK	BLK SW
Q003	2SA1037K	SYNC SEPARATOR
Q004	2SA1037K	SYNC SEPARATOR
Q005	DTC144EK	Y/C SW
Q006	DTC144EK	FRONT/REAR SW
Q007	2SC2412K	MODE 2 SW
Q008	2SC2412K	MODE 1 SW
Q009	2SC2412K	MUTE SW
Q010	2SC2412K	RESET
Q251	2SC2412K	AUDIO MUTE
Q261	2SC2412K	AUDIO MUTE
Q271	2SC2412K	VOLTAGE DETEC
Q502	2SA1037K	CONSTANT CURRENT SOURCE
Q505	2SD774-4	V CENT
Q506	2SB734-3	V CENT
Q507	2SA1037K	CANAL + BLK
Q598	2SA1037K	VIDEO AMP
Q601	2SB1357T114EF	STBY SW
Q602	2SD1548	REG OUT
Q603	2SB1357T114EF	STBY SW
Q604	2SA1037K	FAST ON/OFF
Q605	2SC2412K	STBY SW
Q606	2SC2412K	STBY SW
Q607	2SD2096	+12V REG
Q608	2SC2412K	STBY SW
Q609	2SD789-3	STBY SW
Q801	2SC2412K	ABL AMP
Q804	2SD1941-06	H OUT
Q805	2SC2688-L	H DRIVER
D001	MTZJ6.8C	PROTECT
D002	MTZJ6.8C	PROTECT
D003	1SS133	HUE CTL
D005	MTZJ5.6B	PROT
D006	MTZJ33A	VC VOLTAGE REGULATION
D007	MTZJ3.9B	PLOT RESET
D009	MTZJ5.6B	CLIPPING SYNC LEVEL
D010	MTZJ6.2B	PROT
D011	MTZJ6.2B	PROT
D012	1SS133	PROT
D013	MTZJ6.8C	PROT
D271	MTZJ13B	VOLTAGE DETECT
D272	1SS133	DECOUPLING MUTE AUDIO
D501	1SS133	START
D504	GP08D	V PULSE OUT
D508	1SS133	CANAL + BLK LEVEL
D509	1SS133	V LIN
D511	GP08D	PROT
D512	GP08D	PROT
D513	MTZJ4.7B	PROT
D514	1SS133	PROT
D515	1SS133	PROT
D601	D4SB60L-F	AC RECT
D602	RGP10G	REF RECT
D603	GP08D	SMPS DRIVE 1
D604	GP08D	SMPS DRIVE 2
D605	GP08D	SMPS DRIVE 3
D606	RGP10G	+12V RECT
D607	RGP10G	REF RECT
D608	ERC25-06S	PLUSE CLIPPER
D609	MTZJ33A	FAST ON/OFF
D610	CTU-12S	+14V RECT
D611	ERD29-08J	+13V RECT
D612	CTU-12S	+7V RECT
D613	RGP15J	AF V RECT 1
D614	RGP15J	AF V RECT 2
D616	MTZJ6.2B	+12V REG
D617	1SS133	PROT
D618	MTZJ5.6B	+12V REF
D619	MTZJ33A	FAST ON/OFF 2
D620	DA204K	+12V REF
D621	MTZJ33A	FAST ON/OFF 3
D622	1SS133	PROT
D623	1SS133	DECOUPLING STBY
D624	1SS133	DECOUPLING STBY
D630	MTZJ15A	+12V RECT
D801	RGP10G	+27V RECT
D802	RGP10G	+200V RECT
D803	RGP02-17	G2 RECT
D804	GP08D	H CENTER 1
D805	GP08D	H CENTER 2
D806	ERC06-15S	H DAMPER 1
D807	ERC06-15S	H DAMPER 2
D808	ERD29-08J	PIN DAMPER

IC1651	SBX1610-11	INFRARED RECEIVER
D1651	LD-201VR	AUDIO CHANNEL A INDICATOR
D1652	LD-201VR	AUDIO CHANNEL B INDICATOR
D1654	LD-201VR	RESET

IC103	PCF8574	EXPANDER
Q113	2SC2412K	AUDIO AMP
Q114	2SC2412K	AUDIO AMP
Q115	2SC2412K	AUDIO AMP
Q116	2SC2412K	AUDIO AMP
Q125	DTC144ES	MUTE SW
Q126	DTA144EK	MUTE SW
Q181	2SC2412K	NICAM BUFFER

IC1651	SBX1610-11	INFRARED RECEIVER
D1651	LD-201VR	AUDIO CHANNEL A INDICATOR
D1652	LD-201VR	AUDIO CHANNEL B INDICATOR
D1654	LD-201VR	RESET

Q751	JC501	REF-AMP
Q752	JC501	REF-AMP
Q753	2SB734	PUSH-PULL OUT
Q754	2SD774	PUSH-PULL OUT

**Sony KV-C2949D**  
**chassis AE-1C**  
 (strona 4/4)