

# KA741/E/I

# SINGLE OPERATIONAL AMPLIFIER

## SINGLE OPERATIONAL AMPLIFIERS

The KA741 series are general purpose operational amplifiers which feature improved performance over industry standards like the KA709. It is intended for a wide range of analog applications. The high gain and wide range of operating voltage provide superior performance in integrator, summing amplifier, and general feedback applications.

## FEATURES

- Short circuit protection
- Excellent temperature stability
- Internal frequency compensation
- High Input voltage range
- Null of offset

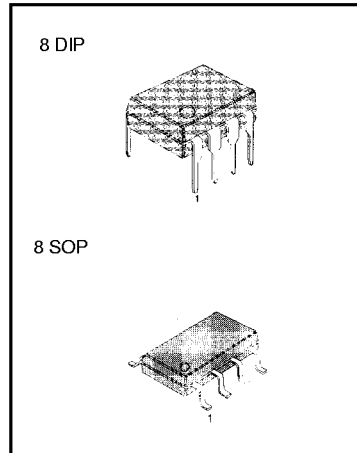

## BLOCK DIAGRAM

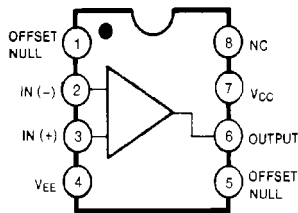

## ORDERING INFORMATION

Device	Package	Operating Temperature
KA741E KA741	8 DIP	0 ~ +70 °C
KA741ED KA741D	8 SOP	
KA741I KA741EI	8 DIP	-40 ~ +85 °C
KA741ID KA741EID	8 SOP	

## SCHEMATIC DIAGRAM

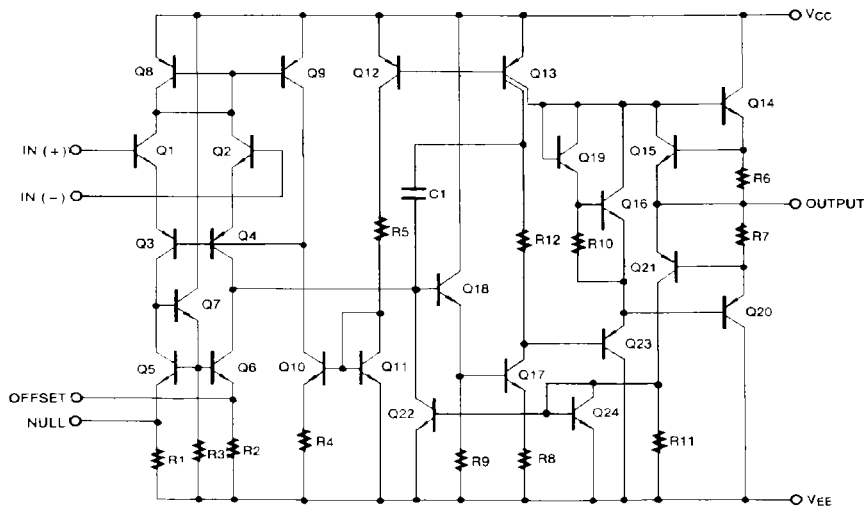

ABSOLUTE MAXIMUM RATINGS (T<sub>A</sub>=25 °C)

Characteristic	Symbol	KA741	KA741E	KA741I	Unit
Supply Voltage	V <sub>CC</sub>	± 18	± 22	± 18	V
Differential Input Voltage	V <sub>I(DIFF)</sub>	± 30	± 30	± 30	V
Input Voltage	V <sub>I</sub>	± 15	± 15	± 15	V
Output Short Circuit Duration		Indefinite	Indefinite	Indefinite	
Power Dissipation	P <sub>D</sub>	500	500	500	mW
Operating Temperature Range	T <sub>OPR</sub>	0 ~ + 70	0 ~ + 70	-40 ~ + 85	°C
Storage Temperature Range	T <sub>STG</sub>	-65 ~ + 150	-65 ~ + 150	-65 ~ + 150	°C

## ELECTRICAL CHARACTERISTICS

(V<sub>CC</sub> = 15V, V<sub>EE</sub> = -15V, T<sub>A</sub> = 25 °C, unless otherwise specified)

Characteristic	Symbol	Test Conditions	KA741E			KA741/KA741I			Unit
			Min	Typ	Max	Min	Typ	Max	
Input Offset Voltage	V <sub>IO</sub>	R <sub>S</sub> ≤ 10KΩ				2.0	6.0		mV
		R <sub>S</sub> ≤ 50Ω		0.8	3.0				
Input Offset Voltage Adjustment Range	V <sub>IO(R)</sub>	V <sub>CC</sub> = ± 20V	± 10			± 15		mV	
Input Offset Current	I <sub>IO</sub>			3.0	30	20	200	nA	
Input Bias Current	I <sub>BIAS</sub>			30	80	80	500	nA	
Input Resistance	R <sub>I</sub>	V <sub>CC</sub> = ± 20V	1.0	6.0		0.3	2.0	MΩ	
Input Voltage Range	V <sub>I(R)</sub>		± 12	± 13		± 12	± 13	V	
Large Signal Voltage Gain	G <sub>V</sub>	R <sub>L</sub> ≥ 2KΩ	V <sub>CC</sub> = ± 20V, V <sub>O(P,P)</sub> = ± 15V	50					V/mV
			V <sub>CC</sub> = ± 15V, V <sub>O(P,P)</sub> = ± 10V				20	200	
Output Short Circuit Current	I <sub>SC</sub>		10	25	35	25		mA	
Output Voltage Swing	V <sub>O(P,P)</sub>	V <sub>CC</sub> = ± 20V	R <sub>L</sub> ≥ 10KΩ	± 16					V
			R <sub>L</sub> ≥ 10KΩ	± 15					
		V <sub>CC</sub> = ± 15V	R <sub>L</sub> ≥ 10KΩ				± 12	± 14	
			R <sub>L</sub> ≥ 10KΩ				± 10	± 13	
Common Mode Rejection Ratio	CMRR	R <sub>S</sub> ≤ 10KΩ, V <sub>CM</sub> = ± 12V				70	90	dB	
		R <sub>S</sub> ≤ 50KΩ, V <sub>CM</sub> = ± 12V	80	95					
Power Supply Rejection Ratio	PSRR	V <sub>CC</sub> = ± 15V to V <sub>CC</sub> = ± 15V R <sub>S</sub> ≤ 50Ω	86	96				dB	
		V <sub>CC</sub> = ± 15V to V <sub>CC</sub> = ± 15V				77	96		
		R <sub>S</sub> ≤ 10KΩ							

## ELECTRICAL CHARACTERISTICS (Continued)

Characteristic	Symbol	Test Conditions	KA741E			KA741/KA741I			Unit
			Min	Typ	Max	Min	Typ	Max	
Transient Response	Rise Time	Unity Gain		0.25	0.8		0.3		$\mu$ s
	Overshoot			6.0	20		10		%
Bandwidth	BW		0.43	1.5					MHz
Slew Rate	SR	Unity Gain	0.3	0.7			0.5		V/ $\mu$ s
Supply Current	$I_{CC}$	$R_L = \infty$					1.5	2.8	mA
Power Consumption	$P_C$	$V_{CC} = \pm 20V$		80	150				mW
		$V_{CC} = \pm 15V$					50	85	

## ELECTRICAL CHARACTERISTICS

( $-40^\circ\text{C} \leq T_A \leq 85^\circ\text{C}$  for the KA7411,  $0^\circ\text{C} \leq T_A \leq 70^\circ\text{C}$  for the KA741 and KA741E.  $V_{CC} = \pm 15V$ , unless otherwise specified)

Characteristic	Symbol	Test Conditions	KA741E			KA741/KA741I			Unit	
			Min	Typ	Max	Min	Typ	Max		
Input Offset Voltage	$V_{IO}$	$R_S \leq 50\Omega$			4.0				mV	
		$R_S \leq 10K\Omega$						7.5		
Input Offset Voltage Drift	$\Delta V_{IO}/\Delta T$			15				$\mu$ V/ $^\circ\text{C}$		
Input Offset Current	$I_{IO}$				70		300	nA		
Input Offset Current Drift	$\Delta I_{IO}/\Delta T$				0.5			nA/ $^\circ\text{C}$		
Input Bias Current	$I_{BIAS}$				0.21		0.8	$\mu$ A		
Input Resistance	$R_I$	$V_{CC} = \pm 20V$	0.5					M $\Omega$		
Input Voltage Range	$V_{I(R)}$		$\pm 12$	$\pm 13$		$\pm 12$	$\pm 13$	V		
Output Voltage Swing	$V_{O(P-P)}$	$V_{CC} = \pm 20V$	$R_S \geq 10K\Omega$	$\pm 16$					V	
			$R_S \geq 2K\Omega$	$\pm 15$						
		$V_{CC} = \pm 15V$	$R_S \geq 10K\Omega$				$\pm 12$	$\pm 14$		
			$R_S \geq 2K\Omega$				$\pm 10$	$\pm 13$		
Output Short Circuit Current	$I_{SC}$		10		40	10	40	mA		
Common Mode Rejection Ratio	CMRR	$R_S \leq 10K\Omega$ , $V_{CM} = \pm 12V$				70	90		dB	
		$R_S \leq 50K\Omega$ , $V_{CM} = \pm 12V$	80	95						
Power Supply Rejection Ratio	PSRR	$V_{CC} = \pm 20V$ to $\pm 5V$	$R_S \leq 50\Omega$	86	96				dB	
			$R_S \leq 10K\Omega$				77	96		
Large Signal Voltage Gain	$G_V$	$R_S \geq 2K\Omega$	$V_{CC} = \pm 20V$ , $V_{O(P-P)} = \pm 15V$	32					V/mV	
			$V_{CC} = \pm 15V$ , $V_{O(P-P)} = \pm 10V$				15			
			$V_{CC} = \pm 15V$ , $V_{O(P-P)} = \pm 2V$	10						

TYPICAL PERFORMANCE CHARACTERISTICS

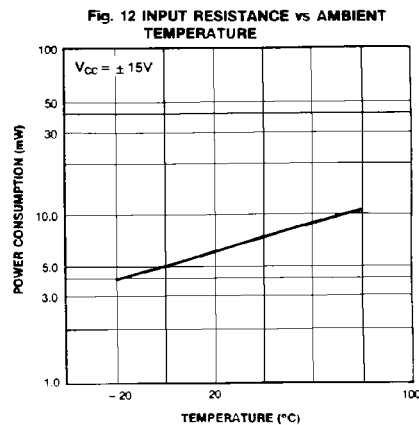
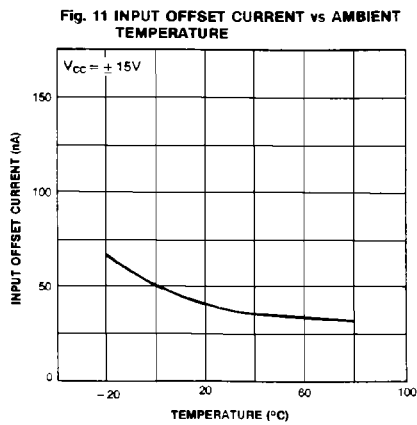
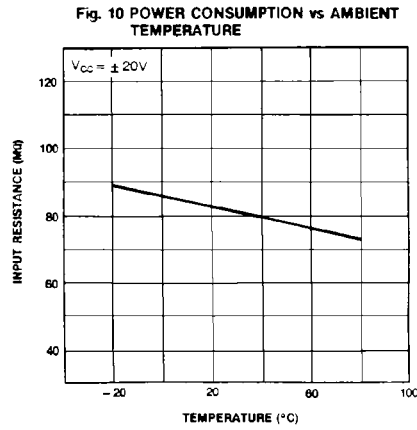
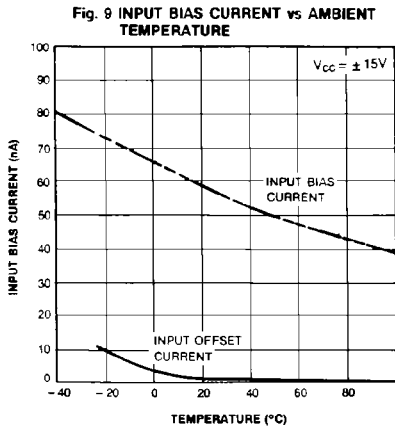
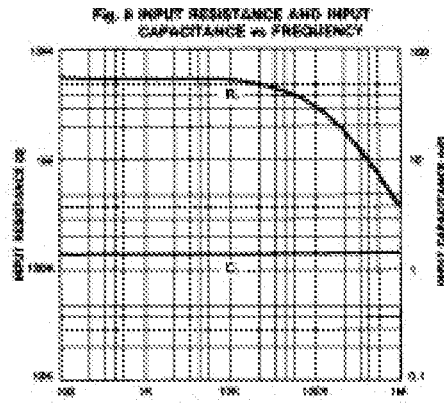
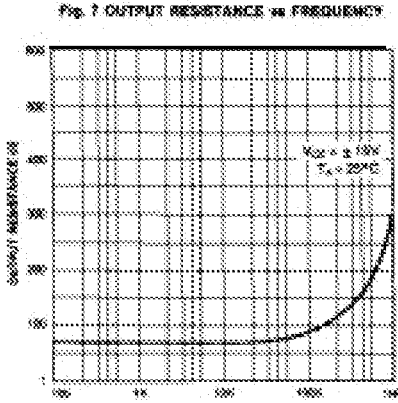

Fig. 13 NORMALIZED DC PARAMETERS vs AMBIENT TEMPERATURE

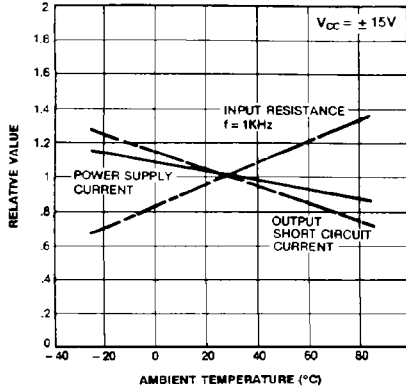

Fig. 14 FREQUENCY CHARACTERISTICS vs AMBIENT TEMPERATURE

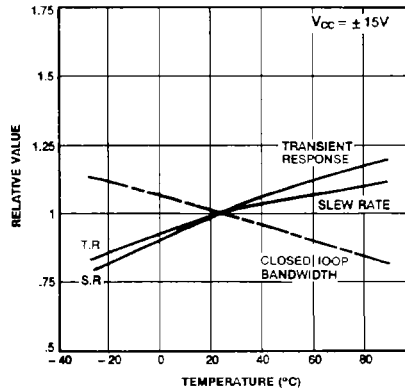

Fig. 15 FREQUENCY CHARACTERISTICS vs SUPPLY VOLTAGE

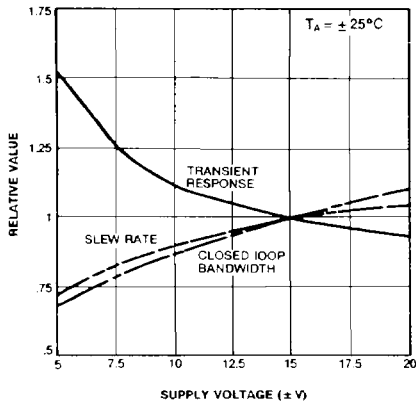

Fig. 16 OUTPUT SHORT CIRCUIT CURRENT vs AMBIENT TEMPERATURE

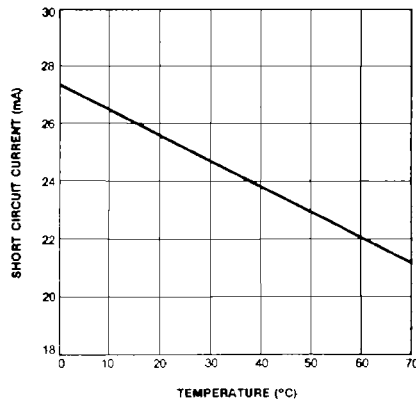

Fig. 17 TRANSIENT RESPONSE

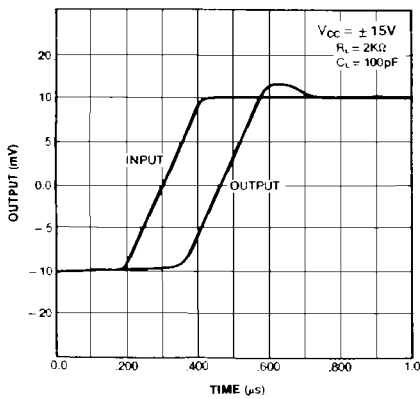

Fig. 18 COMMON-MODE REJECTION RATIO vs FREQUENCY

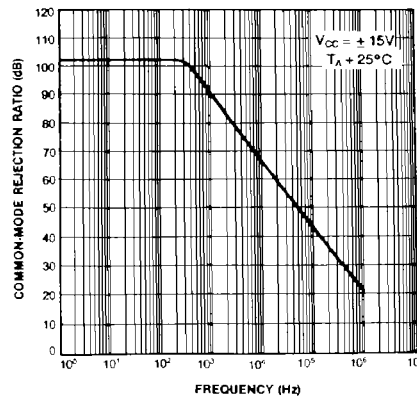

Fig. 18 VOLTAGE FOLLOWER LARGE SIGNAL PULSE RESPONSE

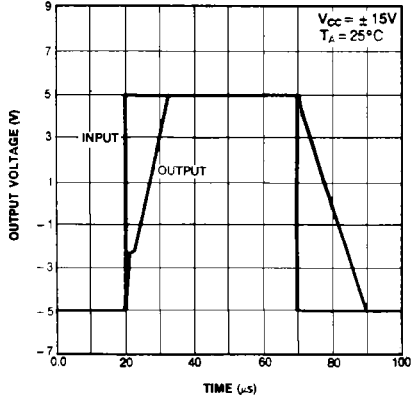
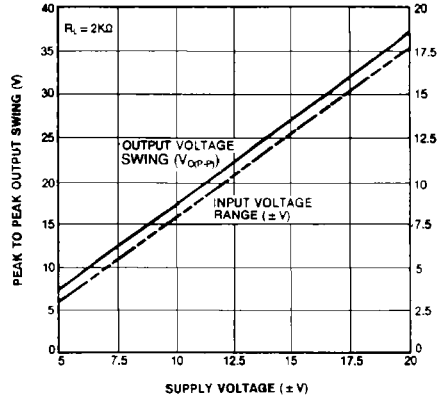

Fig. 19 OUTPUT SWING AND INPUT RANGE vs SUPPLY VOLTAGE



## TRADEMARKS

The following are registered and unregistered trademarks Fairchild Semiconductor owns or is authorized to use and is not intended to be an exhaustive list of all such trademarks.

ACE <sup>x</sup> ™	ISOPLANAR™	UHC™
CoolFET™	MICROWIRE™	VCX™
CROSSVOLT™	POP™	
E <sup>2</sup> CMOS™	PowerTrench™	
FACT™	QST™	
FACT Quiet Series™	Quiet Series™	
FAST®	SuperSOT™-3	
FASTr™	SuperSOT™-6	
GTO™	SuperSOT™-8	
HiSeC™	TinyLogic™	

## DISCLAIMER

FAIRCHILD SEMICONDUCTOR RESERVES THE RIGHT TO MAKE CHANGES WITHOUT FURTHER NOTICE TO ANY PRODUCTS HEREIN TO IMPROVE RELIABILITY, FUNCTION OR DESIGN. FAIRCHILD DOES NOT ASSUME ANY LIABILITY ARISING OUT OF THE APPLICATION OR USE OF ANY PRODUCT OR CIRCUIT DESCRIBED HEREIN; NEITHER DOES IT CONVEY ANY LICENSE UNDER ITS PATENT RIGHTS, NOR THE RIGHTS OF OTHERS.

## LIFE SUPPORT POLICY

FAIRCHILD'S PRODUCTS ARE NOT AUTHORIZED FOR USE AS CRITICAL COMPONENTS IN LIFE SUPPORT DEVICES OR SYSTEMS WITHOUT THE EXPRESS WRITTEN APPROVAL OF FAIRCHILD SEMICONDUCTOR CORPORATION. As used herein:

1. Life support devices or systems are devices or systems which, (a) are intended for surgical implant into the body, or (b) support or sustain life, or (c) whose failure to perform when properly used in accordance with instructions for use provided in the labeling, can be reasonably expected to result in significant injury to the user.
2. A critical component is any component of a life support device or system whose failure to perform can be reasonably expected to cause the failure of the life support device or system, or to affect its safety or effectiveness.

## PRODUCT STATUS DEFINITIONS

### Definition of Terms

Datasheet Identification	Product Status	Definition
Advance Information	Formative or In Design	This datasheet contains the design specifications for product development. Specifications may change in any manner without notice.
Preliminary	First Production	This datasheet contains preliminary data, and supplementary data will be published at a later date. Fairchild Semiconductor reserves the right to make changes at any time without notice in order to improve design.
No Identification Needed	Full Production	This datasheet contains final specifications. Fairchild Semiconductor reserves the right to make changes at any time without notice in order to improve design.
Obsolete	Not In Production	This datasheet contains specifications on a product that has been discontinued by Fairchild semiconductor. The datasheet is printed for reference information only.