



Cinema ProPack 600

# SUB135S

Amplifier/Subwoofer

## SERVICE MANUAL



JBL Consumer Products  
250 Crossways Park Dr.  
Woodbury, New York 11797

Rev1 04/03

**Note: The SUB135S is part of the SCS135S system, which is part of the JBL Cinema Propack 600 system.**

**Satellite loudspeakers 135SAT are replacement-only; order JBL part# SAT135.**

## **- CONTENTS -**

BASIC SPECIFICATIONS.....	1
DETAILED SPECIFICATIONS .....	2
OPERATION .....	3
EXPLODED VIEW.....	4
TEST SET-UP AND PROCEDURE.....	5
BLOCK DIAGRAM.....	6
PCB DRAWINGS.....	7
ELECTRICAL PARTS LIST .....	9
MECHANICAL PARTS LIST.....	11
INTEGRATED CIRCUIT/TRANSISTOR PINOUTS.....	12
SCHEMATICS.....	13

### **BASIC SPECIFICATIONS**

#### **SUB135S Subwoofer**

<b>Configuration:</b>	Floor-firing, bass-reflex ported enclosure
<b>Woofers:</b>	8" cone
<b>Amplifier Power output:</b>	100W Continuous RMS power @ 0.8% THD, 20Hz to 100Hz
<b>LFE Input Voltage/Impedance:</b>	2V p-p/47k ohms
<b>Dimensions:</b>	Width: 13 inches (330mm) Height: 15 inches (381mm) Depth: 14 inches (356mm)
<b>Weight:</b>	30 lb/13.6kg

Occasional refinements may be made to existing products without notice but will always meet or exceed original specifications unless otherwise stated

# SUB135S Cinema ProPack 600



## SUB135S 100W Powered Amplifier

LINE VOLTAGE	Yes/No	Hi/Lo Line	Unit	Notes
US 120vac/60Hz	Yes	108-132	Vrms	Normal Operation
Asia 100vac/50Hz	Yes	90-110	Vrms	Normal Operation

Parameter	Specification	Unit	QA Test Limits	Conditions	Notes
<b>Amp Section</b>					
Type (Class AB, D, other)	AB	AB	n/a		External Sink required for Class AB
Load Impedance (speaker)	4	Ohms	n/a	Nominal	Z-curve required
Rated Output Power	100	Watts	90	1 input driven	
THD@ Rated Power	0.08	%	0.3	22k filter	
THD @ 1 Watt	0.1	%	0.5	22k filter	
DC Offset	10	mV-DC	20	@ Speaker Outputs	
Damping factor	>75	DF	50		Measured at speaker terminals, Output power 90 Watts THD 0.1 %
<b>Input Sensitivity</b>					
Input Frequency	50	Hz	50	Nominal Freq.	1 input driven
LFE Input	550	mVrms	±2dB	To Rated Power	LFE input
<b>Signal to Noise</b>					
SNR-A-Weighted	100	dBa	85	rel. to rated power	A-Weighting filter
SNR-unweighted	85	dB	85	rel. to rated power	22k filter
SNR @ 1W-unweighted	65	dB	60	rel. to 1W Output	22k filter
Residual Noise Floor	1	mVrms	1.5	Using RMS reading DMM/VOM (or A/P)	LFE Input terminated with 600 Ohms
Residual Noise Floor	1	mVrms(max)	1.5	Using A/P Swept Bandpass Measurement (Line freq.+ harmonics)	
<b>Input Impedance</b>					
Line input L&R , LFE	>15	K ohms	n/a	Nominal	
<b>Filters</b>					
Low Pass (fixed or variable)	fixed	--	±2dB		
Slope & Q		dB/Octave	n/a		
Subsonic filter (HPF)		Hz	±2dB		
Slope & Q		dB/Octave	n/a		
Limiting (yes/no)	YES	--	n/a		Limiting diode current should not exceed 5% when input is overloaded by 3 times its input sensitivity
<b>Features</b>					
LFE Input	YES		functional		BW Limited to 500 Hz
ATO	YES		functional		
<b>Signal Sensing (ATO)</b>					
Auto-Turn-On (yes/no)	YES	--	functional		
ATO Input Frequency	50	Hz	functional		
ATO Level	2	mV	functional	2mV@50Hz into Line Input w/ 1 ch. driven	
ATO Turn-on time	5	ms	functional	Amp connected and AC on, then input signal applied	
Auto Mute/ Turn-OFF Time	15	minutes	functional	T before muting, after signal is removed	Auto turn of time (T) must be 10 > T <15
Power on Delay time	3	sec.	functional	AC Power Applied	
<b>Transients/Pops</b>					
ATO Transient	5	mV-peak	10	@ Speaker Outputs	
Turn-on Transient	50	mV-peak	100	@ Speaker Outputs	AC Line cycled from OFF to ON
Turn-off Transient	50	mV-peak	100	@ Speaker Outputs	AC Line cycled from ON to OFF
<b>Efficiency</b>					
Stand-by Input Power	13	Watts	15	@ nom. line voltage	Maximum allowable input power under nominal Input voltage and frequency, HOT or COLD operation.
Power Cons.@rated power	185	Watts	195	@ nom. line voltage	100 Watts @ 4 Ohms nominal line voltage
<b>Protection</b>					
Short Circuit Protection	YES	--	functional	Direct short at output	
Thermal Protection	65 deg. C	--	functional	@ 1/8 max unclipped Power	Temperature rise should not exceed 35K rise
DC Offset Protection	YES	--	functional	DC present at Speaker Out leads	Relay or crowbar (for driver/fire protection)
Line Fuse Rating	2.5	Amps	2.5	Type-T or Slo Blo	External fuse with UL/SEMKO rated holder

# Operating the SUB135S Subwoofer

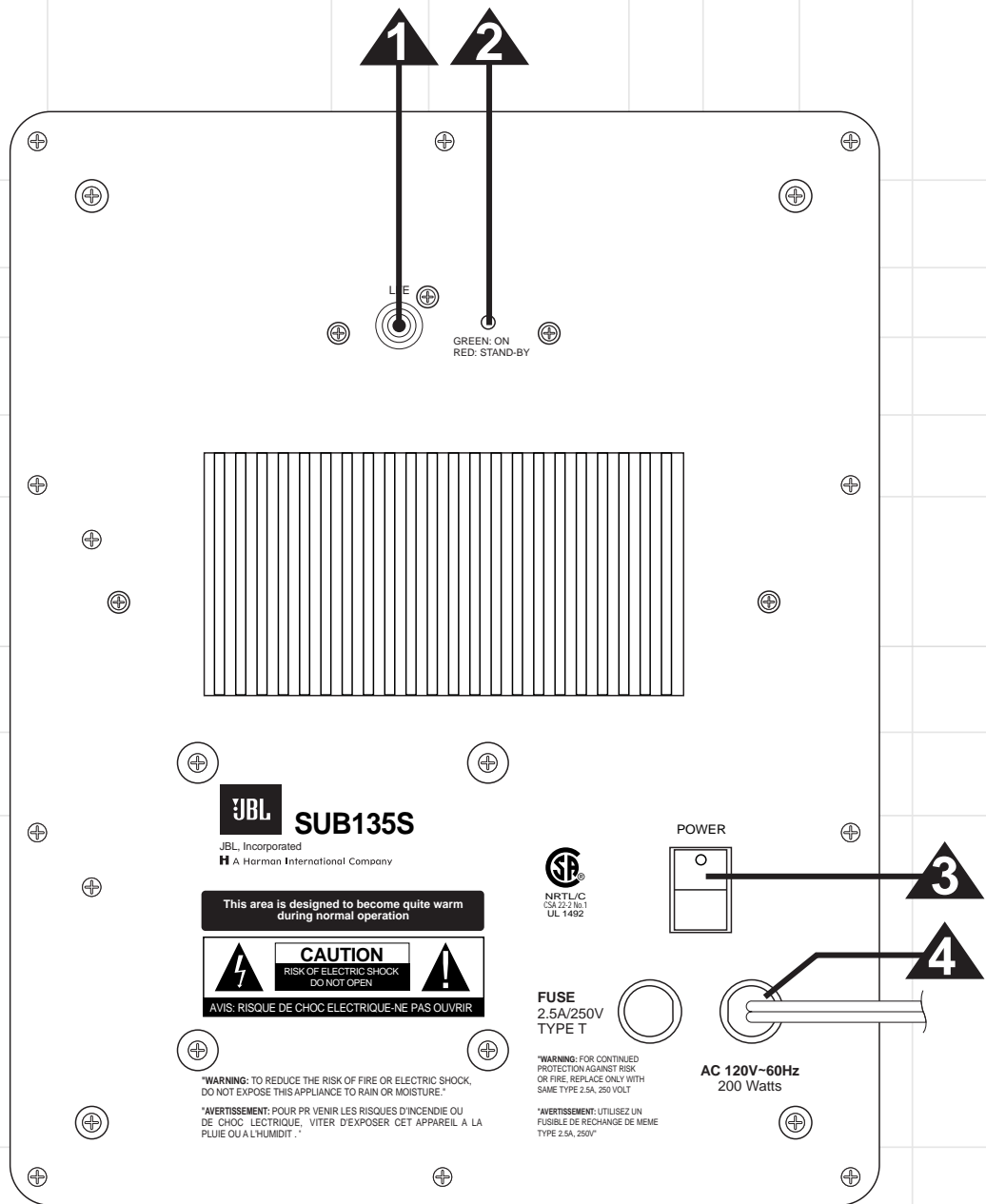

**▲ LFE Input:** Connect to LFE/Subwoofer Output on rear panel of DCR600 receiver using the single-lead RCA cable with brown connectors.

**▲ LED:** Lights green when a low-frequency signal is present and the subwoofer is playing. Lights red when no low-frequency audio signal is present to indicate that the subwoofer is plugged in, powered on and in the Standby mode.

**▲ Power Switch:** Turn the power switch to the "•" (dot) position to power the unit on. The SUB135S subwoofer will automatically turn itself on and go into Standby (Sleep) mode when left in the On position. When your DCR600 is off, or is not sending program material to the subwoofer, the subwoofer will be in Standby mode. When the subwoofer senses an audio signal, it will automatically turn itself on. If the subwoofer does not sense a signal after approximately twenty minutes, it will automatically go into Standby mode. If you will be away from home for an extended period of time, or if

the subwoofer will not be used, turn this switch off to conserve electricity and for safety.

**▲ AC Power Cord:** Plug the power cord into an unswitched outlet.

**SUB135S EXPLODED VIEW/MECHANICAL LIST**

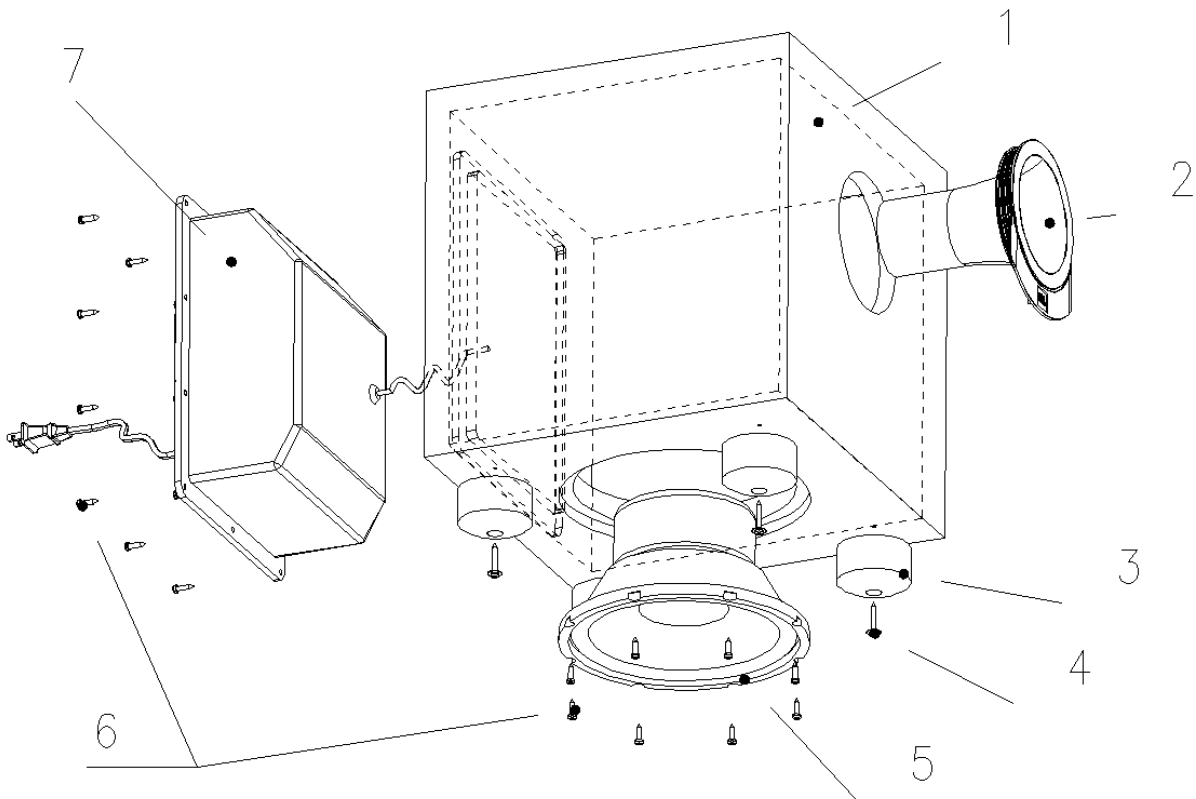

ID	DESCRIPTION	PART#	QTY
1	Cabinet	Not For Sale	1
2	Port Tube	wi5215	1
3	Main Foot	wi5447	4
	Rubber Pad for Foot	wi5448	4
4	Screw	06-t5345005	1
5	8" Woofer	20MF10DAG-DW03	1
6	Screw	06-t4205012	18
7	Amplifier Assembly	Not For Sale	1

## SUB135S Test Set Up and Procedure



### SYSTEM AURAL SWEEP TEST

#### Equipment needed:

- Function/signal generator/sweep generator
- Integrated Amplifier
- Multimeter

#### General Unit Function (UUT = Unit Under Test)

1. From the signal generator (set initially at 0 volts), connect one line level (RCA) cable to the SUB135S LFE jack on the UUT.
2. Plug in the power cord; turn the power switch ON. LED should be Red.
3. Turn up the generator and adjust to **300mV, 40 Hz**. LED should now be Green.
4. Immediate bass response should be heard and felt from port tube opening.

#### Sweep Function

1. Follow steps 1-4 above, using a sweep generator as a signal source.
2. Sweep generator from 20Hz to 1kHz. Listen to the cabinet and drivers for any rattles, clicks, buzzes or any other noises. If any unusual noises are heard, remove woofer and test.

#### Driver Function (Woofer)

1. Remove woofer from cabinet; detach the + and - wire clips.
2. Check DC resistance of woofer; it should be **3.4 ohms  $\pm 10\%$** .
3. Connect a pair of speaker cables to driver terminals. Cables should be connected to an integrated amplifier fed by a signal generator. Turn on generator and adjust so that speaker level output is **5.0V**.
5. Sweep generator from 20Hz to 1kHz. Listen to driver for any rubbing, buzzing, or other unusual noises.

Caution: take care to replace the + and - wire clips on the correct terminals, as they are the same size. Red wire should connect to the red dot on the terminal.

# BLOCK DIAGRAM

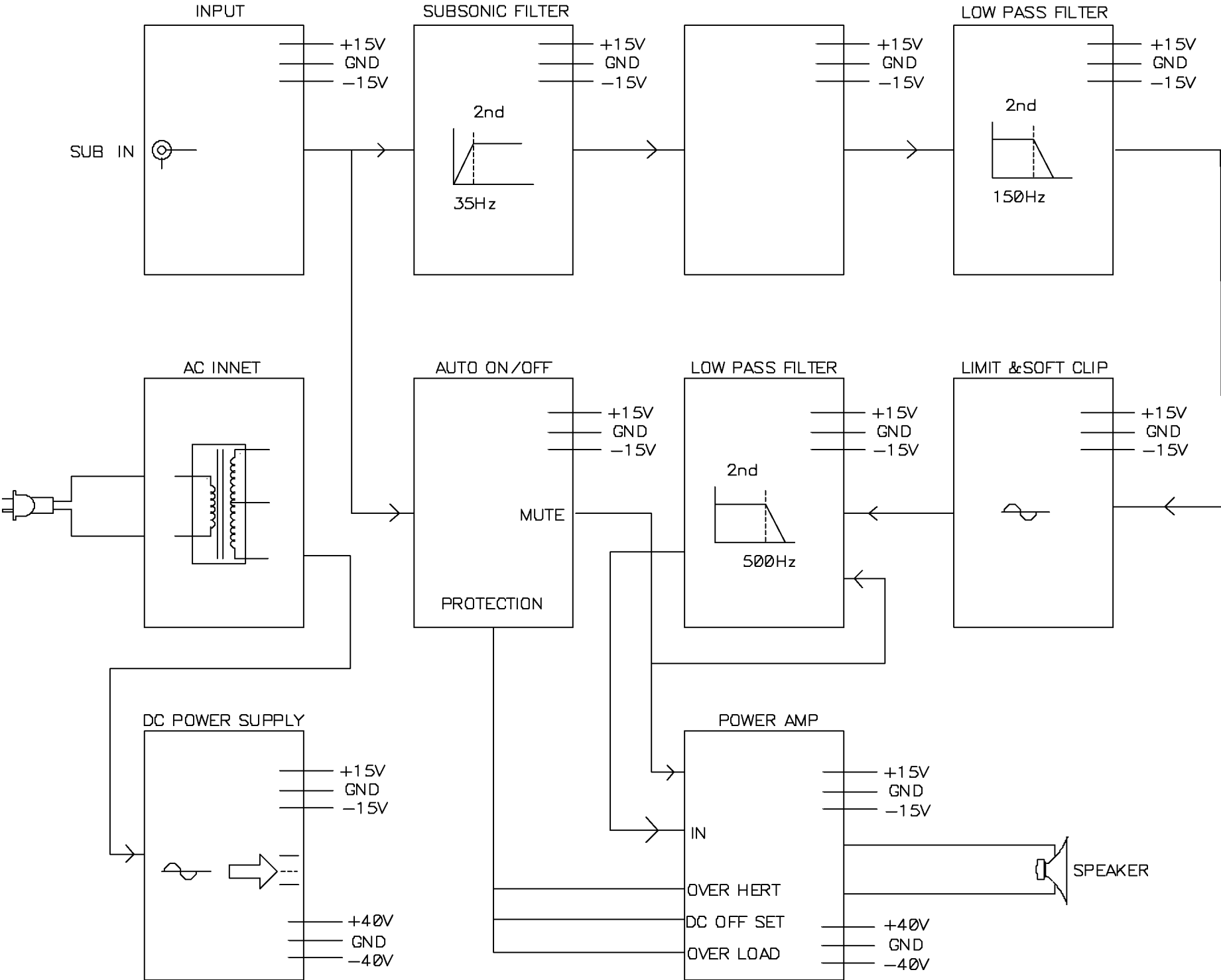

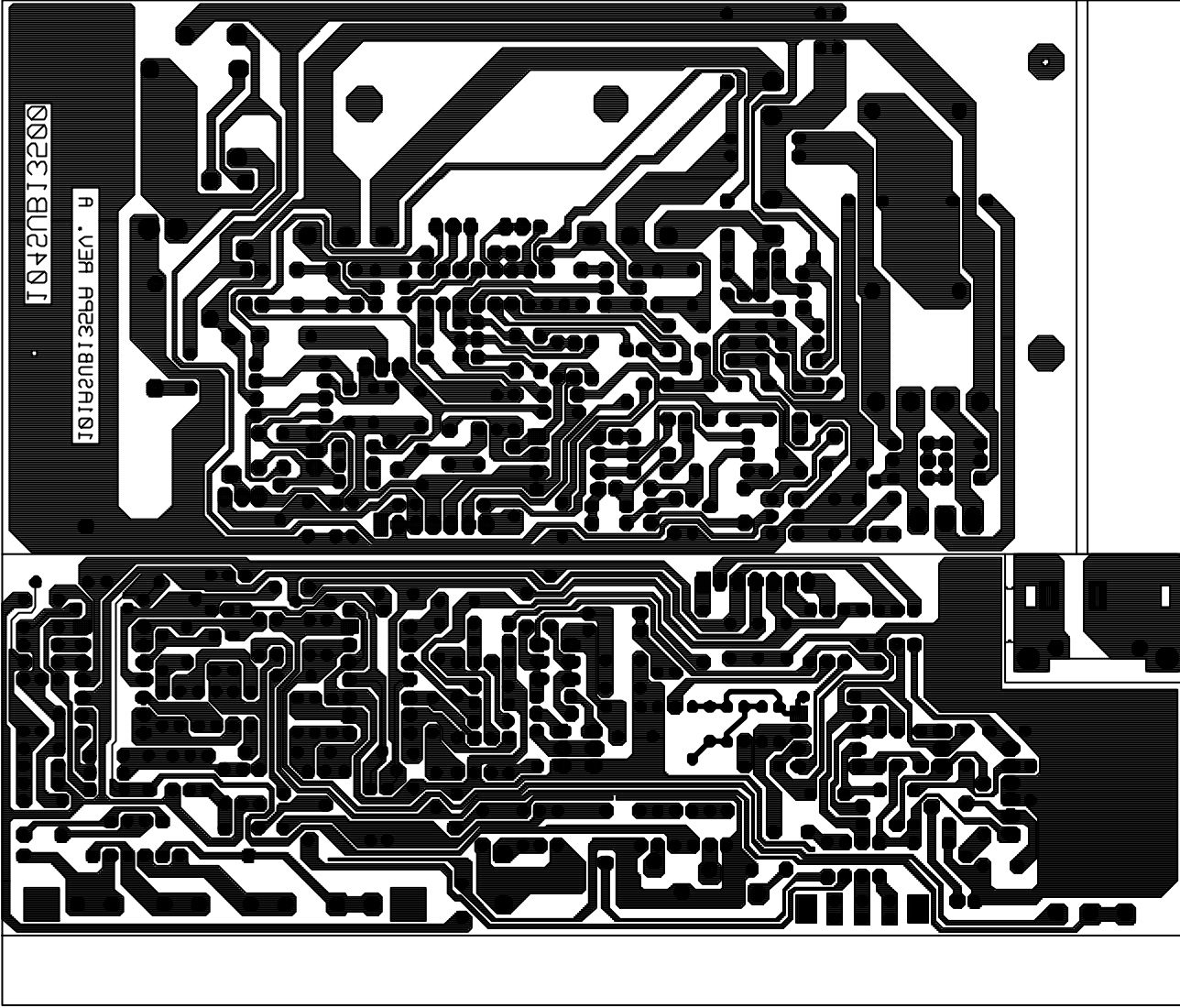

J042NBJ3200

J01A2UBI326A REV. 0



104SUB13500

RY101

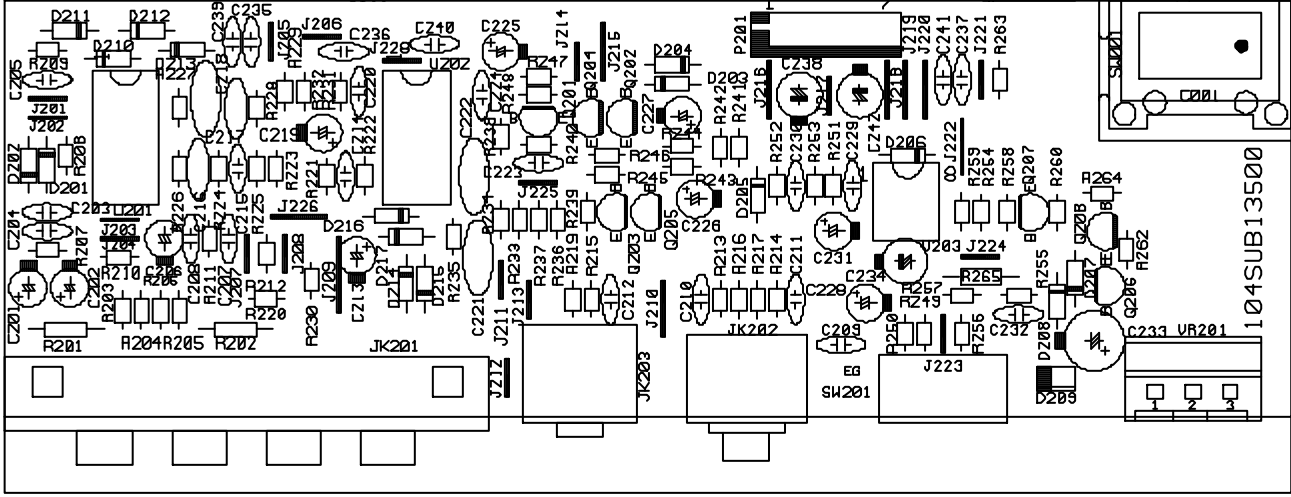
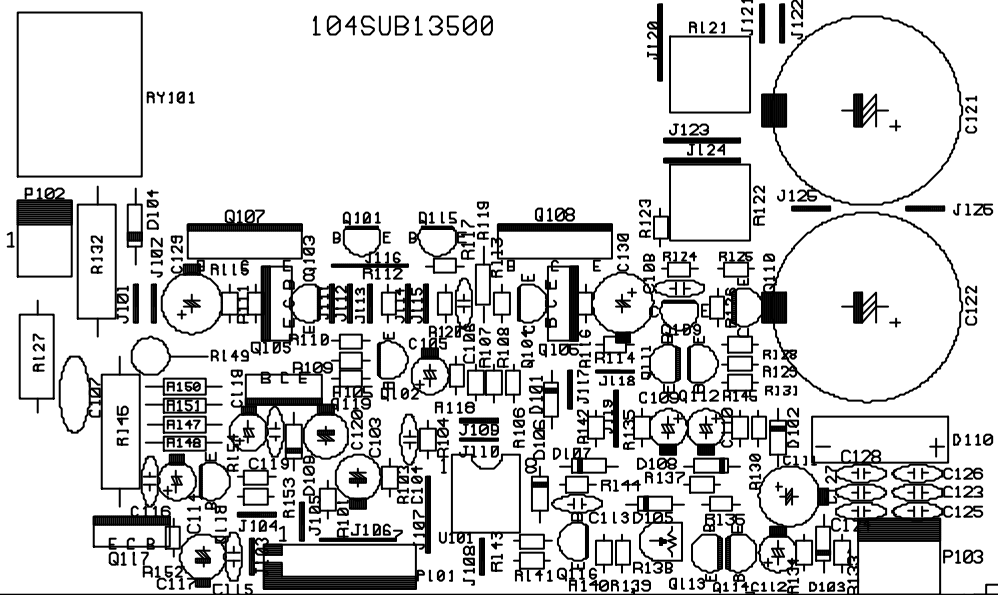

104SUB13500

# JBL SUB135S Electrical Parts List

Part Number	Description	QTY	Reference Designator
<b>Main/Input PCB</b>			
<i>Semiconductors</i>			
192027c1815gr	Transistor 2SC1815gr NPN	8	Q102,111,112,113,118,206,207,208
192028A1015gr	Transistor 2SA1015GR tap PNP	2	Q114,116
1921672n5551	Transistor 2N5551 tap NPN	2	Q103,109
1921682n5401	Transistor 2N5401 AI-PNP 350V	2	Q104,110
197131n4148	1N4148 26mm Diode	9	D101,103,105,108,206,207,208,214,215
19915000335	Zener diode 3.3V 1/2W 52mm	2	D102,205
19915000625	Zener diode 6.2V 1/2W 52mm	2	D106,107
19915001605	Zener diode 16V 1/2W 52mm	1	D109
19006m4558d	IC OPA 4558 Dual Op-Amp	2	U101,203
19016tl074cn	IC TL074CN ST Quad Op-Amp	1	U202
192011d669a	Transistor 2SD669A NPN	1	Q106
192012b649a	Transistor 2SB649A PNP	1	Q105
1920251tip35c	Transistor TIP35C NPN	1	Q107
192022tip36c	Transistor TIP36C PNP	1	Q108
192201d882y	Transistor KSD882Y NPN	1	Q117
192202b772y	Transistor KSB772Y PNP	1	Q119
19700kbl405	Diode Bridge 4A 500V KBL405	1	D110
197131n4002	1N4002 26mm TAP Diode	2	D104
19510204hgw	LED 204HGW	1	D209
<i>Resistors</i>			
11010821jk1	Resistor 820 Ohm 1W	1	R132
110122r2j15	Resistor 2.2 Ohm	1	R127
11020331jk2	Resistor 330 Ohm 2W 5mm	1	R146
11020331jk3	Resistor 330 Ohm 2W 7.5mm	1	R149
113500r1j20	cement Resistor 0.1 Ohm 5W	2	R121,122
11403302m0	SVR 3K 0.3W 20%	1	R138
11014472j26	Resistor 4.7K 1/4W	1	R147,50
11014681j26	Resistor 680 Ohm 1/4W	2	R148,51
11016101j26	Resistor 100 Ohm 1/6W	2	R120,215
11016102j26	Resistor 1k 1/6W	2	R124,254
11016103j26	Resistor 10k 1/6W	7	R134,230,232,235,240,260,264
11016105j26	Resistor 1M 1/6W	2	R143,259
11016123j26	Resistor 12k 1/6W	2	R135,139
11016124j26	Resistor 120k 1/6W	1	R233
11016151j26	Resistor 150 Ohm 1/6W	1	R253
11016152j26	Resistor 1.5k 1/6W	6	R103,123,136,137,141,142
11016153j26	Resistor 15k 1/6W	5	R118,145,152,154,234
11016154j26	Resistor 150k 1/6W	2	R131,252
11016181j26	Resistor 180 Ohm 1/6W	2	R111,114
11016182j26	Resistor 1.8k 1/6W	1	R153
11016183j26	Resistor 18k 1/6W	1	R262
11016205j26	Resistor 2.0M 1/6W	1	R257

Part Number	Description	QTY	Reference Designator
11016223j26	Resistor 22K 1/6W	7	R128,129,133,237,238,255,263
11016332j26	Resistor 3.3k 1/6W	3	R106,107,144
11016392j26	Resistor 3.9k 1/6W	2	R105,108
11016393j26	Resistor 39k 1/6W	1	R126
11016470j26	Resistor 47 Ohm 1/6W	4	R112,113,115,116
11016471j26	Resistor 470 Ohm 1/6W	1	R140
11016472j26	Resistor 4.7k 1/6W	4	R110,125,130,258
11016473j26	Resistor 47k 1/6W	4	R101,219,250,251
11016560j26	Resistor 56 Ohm 1/6W	1	R117
11016563j26	Resistor 56k 1/6W	1	R104
11016682j26	Resistor 6.8K 1/6W	1	R109
11016822j26	Resistor 8.2K 1/6W	1	R231

### Capacitors

1302g472md00	PE capacitor 4700p 400V	1	
132223ja03	Capacitor 0.022uf 100V	2	C123,127
1353107m16	Capacitor 100uf 16V	1	C110
1354688m50	Capacitor 6800U/50V	2	C121,122
1302b101k503	PE Capacitor 100P 50V	1	C220
1302b102k503	Capacitor 1000P 50V	1	C116
1302b221k503	Capacitor 220P50V	2	C212,230
1302f104z503	Capacitor 0.1U 50V	9	C108,113,115,119,232,236,237,240,241
1303f473m503	Capacitor 0.047U 50V	1	C106
130sl 470k503	Capacitor 47P 50V	1	C229
132103j503	Capacitor 0.01U 50V	2	C223,224
132104j503	Capacitor 0.1U 50V	3	C107,221,222
132223ja03	Capacitor 0.022uf 100V	4	C124,125,126,128
1353105m50	Capacitor 1U 50V	3	C105,112,228
1353106m50	Capacitor 10U 50V	2	C219,231
1353107m16	Capacitor 100uf 16V	6	C109,117,120,234,238,242
1353226m50	Capacitor 22U 50V	3	C114,118,225
1353227m10	Capacitor 220U 10V	2	C129,130
1353227m16	Capacitor 220U 16V	2	C111,233
1353476m25	Capacitor 47U 25V	1	C103

### Misc.

653hs135-s	heat sink 65*32*31	1	
712a130	IC spacer	2	
1933m2520	mica sheet T0-3P 25*20mm	2	For Q107,108
171udhss124d	Relay 5A 24V YDH-SS124D	1	RY101
1740rca108	Single RCA jack	1	JK203
1751c07v01	coupling 7pin pitch=2.5mm	1	P101
1751d02v01	coupling 2pin pitch=3.96mm	1	P102
192022tip36c	LED socket 14.2*8.0*5.2 t=1.6mm	1	

### Limiter PCB

192027c1815gr	Transistor 2SC1815gr NPN	2	Q301,302
197131n4148	1N4148 26mm Diode	2	D301,302

Part Number	Description	QTY	Reference Designator
19016tl074cn	I.C. TL074CN ST Dual Op-Amp	1	U301
11016103j26	Resistor 10K 1/6W	7	R301,302,303,304,308,309,314
11016223j26	Resistor 22k 1/6W	2	R310,312
11016333j26	Resistor 33k 1/6W	1	R305
11016474j26	Resistor 470k 1/6W	1	R307
11016751j26	Resistor 750 Ohm	2	R311,313
11016755j26	Resistor 7.5M 1/6W	1	R306
1302f104z503	Capacitor 0.1U 50V	2	C305,306
132103j503	PE Capacitor 0.01U 50V	2	C302,303
1353226m50	PE Capacitor 22U 50V	1	C301
1353476m25	PE Capacitor 47U25V	1	C304
16210059001	wire 50mm white UL1007	1	
16250129001	cable ASS'Y 120mm	1	P302
1759f40hr2	coupling 40pin pitch=2.54mm	1	P301

## Mechanical Parts list

602p8300800	screw M3*8	6	R/P TO BRKT-2,PCB TO BRKT-4
602c8401610	screw M4*16	4	XFORMER-4
610gm4b	screw nut for M4	4	XFORMER-4
607p8300800	B type screw 3*8	8	L-H/S TO R/P-6,R/P TO S-H/S-2
606p8301000	P type screw 3*10	2	JK201,202
600b8401200	screw 4*12	4	R/P TO R/C-4
150e8604107	transformer EI-86 120v 60Hz	1	
152u602015	power cord 2 cond. 6 Ft.	1	
154u25006t0	Fuse 2.5A 250v 20mm	1	FS101
155520020	Fuse holder R3-11	1	
16210082007	wire red AWG18 80mm	1	
16210372000	speaker wire UL1015 370mm	1	
176wjce1	terminal CE-1	1	
180pbr12c11s	Power Off/On switch BR12C11S	1	SW101
640rp135s	aluminum faceplate 215*270*2.5t	1	
650sub240	frame for PCB L type T=1.6mm	2	
653hs135-1	heat sink 117.5*60*25	1	
700rc800a	rear cabinet 268*213*102	1	
723a125	EVA gasket 213*15*2.0mm	2	
723a125-1	EVA gasket 213*15*1.0t	2	
725b125	EVA gasket 238*15*2.0mm	2	
723b125-1	EVA gasket 238*15*1.0t	2	
723j125	EVA gasket 225*15*1t UL	1	
725a125	rubber gasket 25*21*4t	4	
156b010010	connector wire 100mm	2	

# Integrated Circuit Diagrams

4558 DUAL OP AMP,  
U101, 203

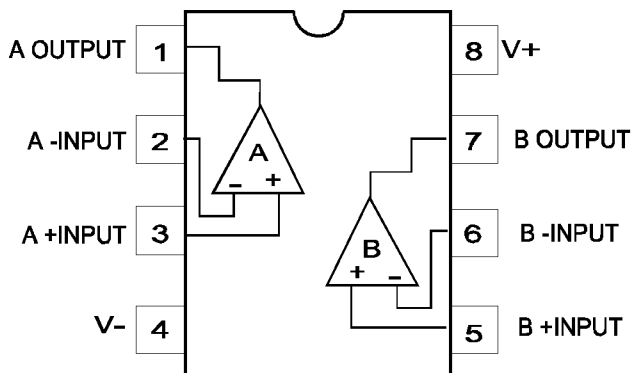

OPAMP, QUAD 14P DIL TL074  
U202, 301

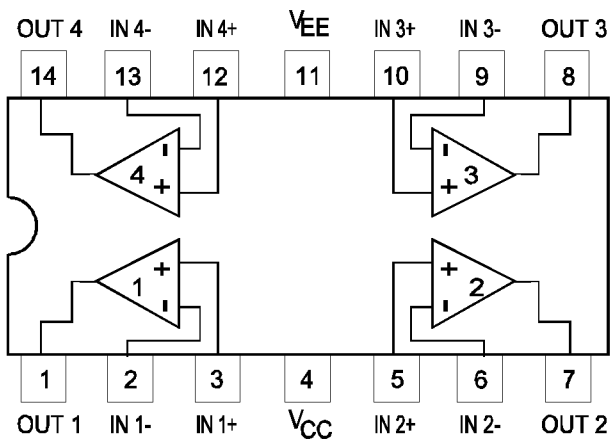

TRANS, PNP, 2N5401 TAP,  
TO-92,  
Q104,110

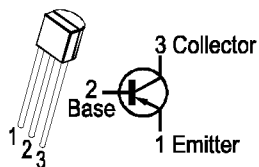

TRANS, NPN, 2N5551 TAP,  
Q103,109

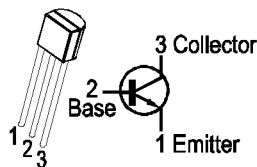

TRANS, NPN, 2SC1815GR TAP,  
KSD882Y  
Q102,111-113,117,118,206-208,  
301,302

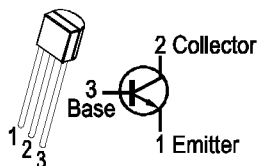

TRANS, PNP, TAP,  
2SA1015GR, KSB772Y  
Q114,116,119

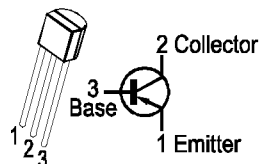

TIP35C NPN,  
TIP36C PNP,  
Q107,108

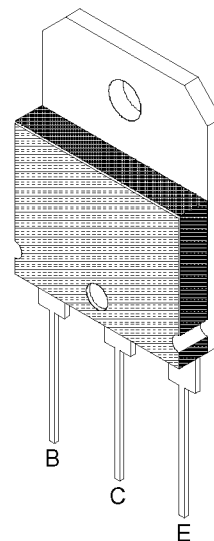

2SD 669  
2SB 649  
Q105,106

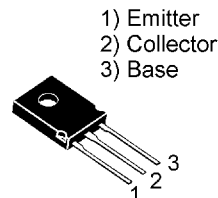

# SUB135S Cinema ProPack 600

SCS135S .SCH

DEC. 10. 2000

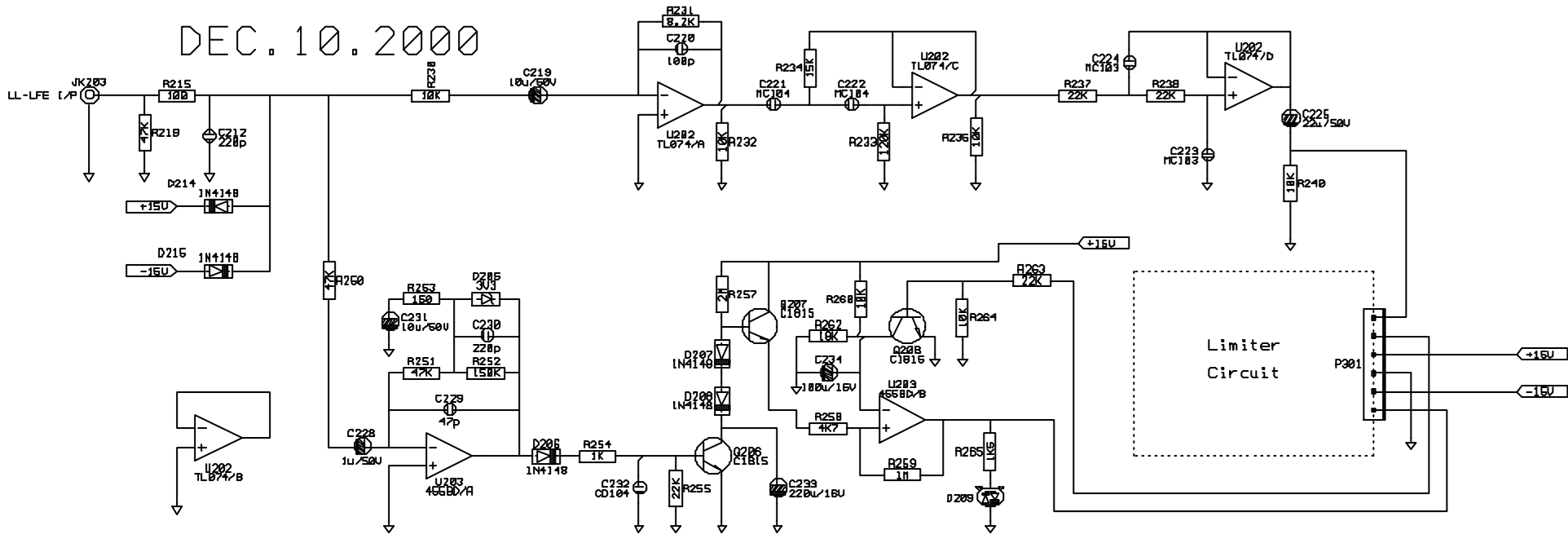

# SUB135S Cinema ProPack 600

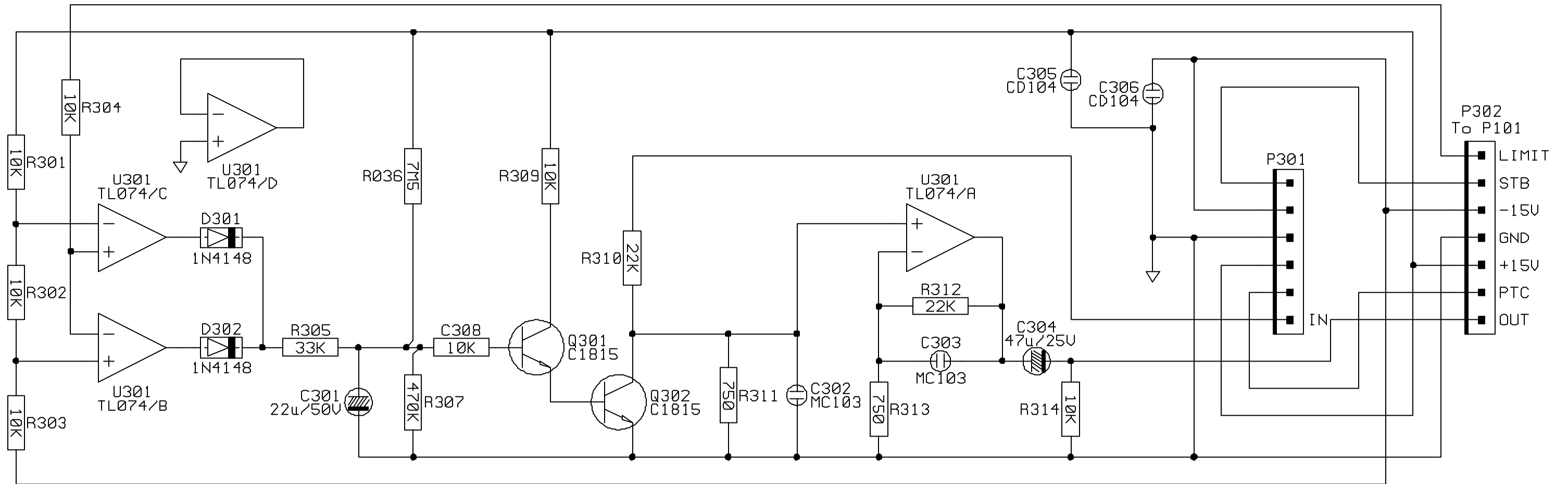

# SUB135S Cinema ProPack 600

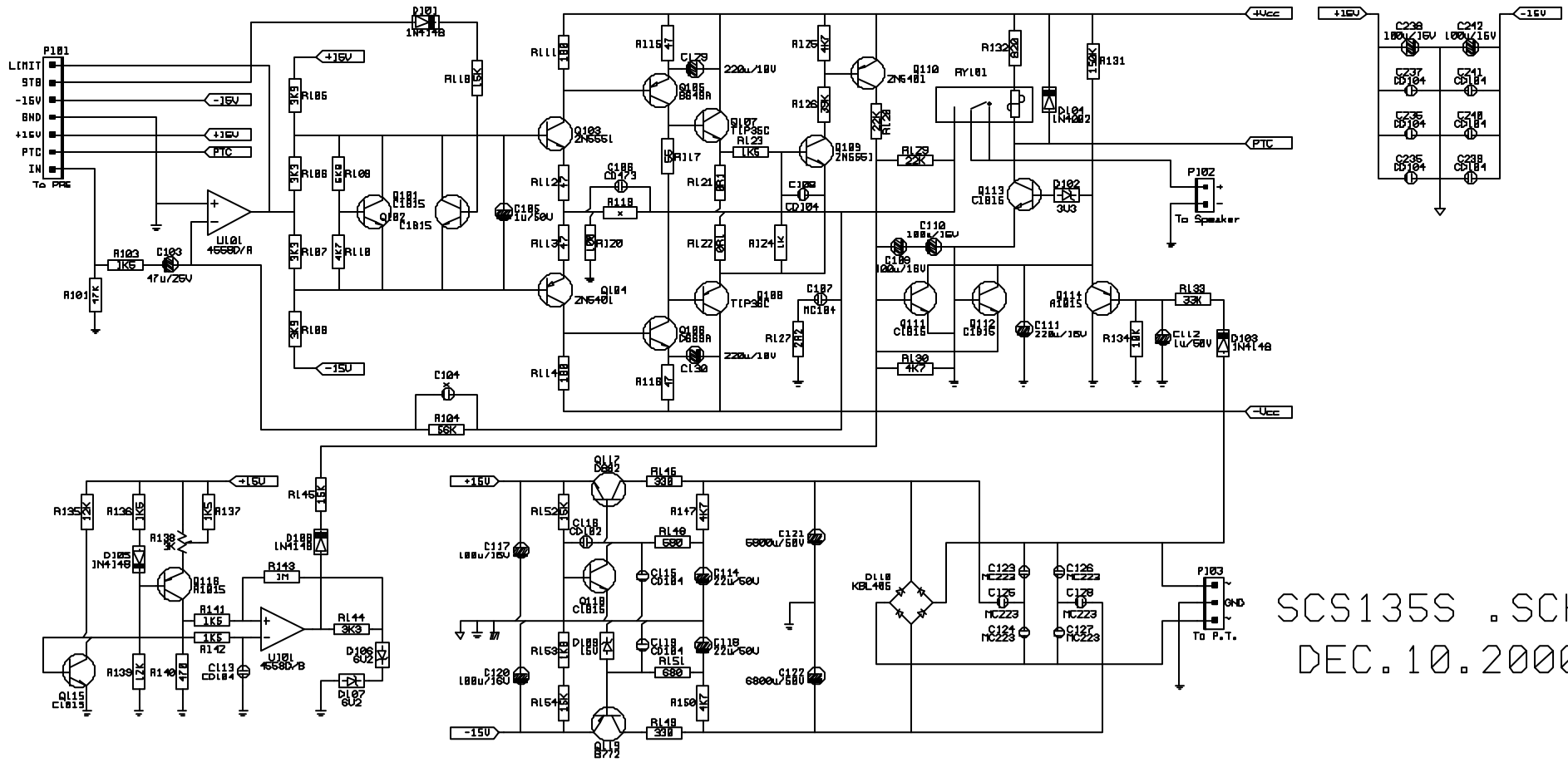

SCS135S .SCH  
DEC.10.2000