



For more Hi-Fi manuals and set-up information
please visit www.hifiengine.com

ONKYO SERVICE MANUAL

SERVO LOCKED FM/AM STEREO RECEIVER MODEL TX-2500MK II

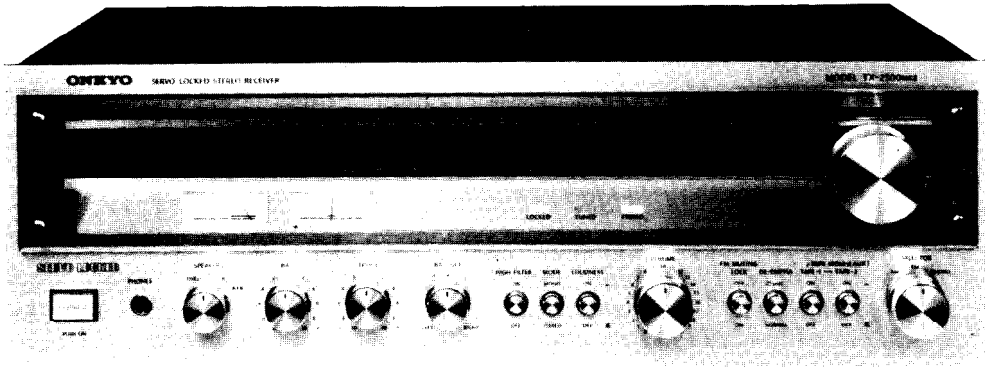

TABLE OF CONTENTS

Item	Page
Specifications	2
Service notes	2
Component location	4
Exploded view	5
Alignment Procedures	6
Stringing diagram	8
Schematic diagram	9
Printed circuit board view	11
Parts list	14
Block diagram	15
Circuit description	15
Packing procedures	17

ONKYO®
AUDIO COMPONENTS

SPECIFICATIONS

Amplifier section

Power Output	40 watts per channel, min. RMS, at 8 ohms both channels driven, from 20 Hz to 20 kHz, with no more than 0.1% total harmonic distortion.
Total Harmonic Distortion	0.1% at rated power
IM Distortion	0.08% at 1 watt output 0.3% at rated power
Damping Factor	40 at 8 ohms
Frequency Response	20 ~ 30,000 Hz (± 1 dB)
Sensitivity and Impedance	PHONO: 2.5 mV 50 kohms TAPE PLAY: 150 mV 50 kohms TAPE REC: 150 mV 3.5 kohms (PHONO)
Phono Overload	150 mV RMS at 1 kHz 0.1% THD.
Treble Control	± 10 dB at 10 kHz
Bass Control	± 12 dB at 100 Hz
Signal to Noise Ratio	PHONO: 85 dB (at 10 mV input IHF A network) 65 dB (IHF C network) TAPE: 95 dB (IHF A network) 90 dB (IHF C network)
High Filter	6 kHz 6 dB/oct.
Loudness (-30 dB)	+9 dB at 40 Hz +5 dB at 20 kHz

Tuner section

Tuning Range	FM: 88 ~ 108 MHz AM: 530 ~ 1605 kHz
Usable Sensitivity	FM mono: 11.2 dBf, 2 μ V FM stereo: 19.2 dBf, 5 μ V AM: 25 μ V

50 dB Quieting Sensitivity	FM mono: 17.2 dBf, 4 μ V FM stereo: 37.2 dBf, 40 μ V
Intermediate frequency	FM: 10.7 MHz AM: 455 kHz
Capture Ratio	FM: 2 dB
Image Rejection Ratio	FM: 45 dB AM: 45 dB
IF Rejection Ratio	FM: 80 dB AM: 30 dB
Spurious Rejection	FM: 1/2 IF 80 dB
Signal to Noise Ratio	FM mono: 65 dB FM stereo: 60 dB AM: 40 dB
ACA	FM: 60 dB
AM Suppression Ratio	FM: 50 dB
Harmonic Distortion	FM mono: 0.2% FM stereo: 0.4% AM: 0.8%
Frequency Response	FM: 30 ~ 15,000 Hz +0.5, - 2 dB
Stereo Separation	FM: 37 dB at 1 kHz 30 dB at 100 ~ 10,000 Hz
Muting Level	FM: 14.7 dBf, 3 μ V
Stereo Threshold	FM: 14.7 dBf, 3 μ V
Locked Level	FM: 14.7 dBf, 3 μ V
Tuning Meter	Signal strength & Center tuning

General

Power Supply	AC 120 volts 60 Hz 130 watts
Dimensions	19"W x 6-5/16"H x 14-5/8"D 483mmW x 160mmH x 371mmD
Weight	25.3 lbs. 11.5 kg.
Semiconductors	1 FET, 30 Transistors, 8 ICs, 28 Diodes

Specifications are subject to change without notice for improvement.

SERVICE NOTES

1. REPLACEMENT OF THE AC FUSE

- 1) Remove four screws holding leg and bottom board.
- 2) Remove five screws holding bottom board and side bracket.
- 3) Replace the AC fuse on the power supply p.c.b.

2. REPLACEMENT OF THE SPEAKER PROTECTION FUSE

- 1) Remove a screw holding the cover and back panel and remove the cover.
- 2) Replace the fuse with indicial 4-ampere types.

3. When replacing differential amplifier or push-pull amplifier transistors, be sure that transistors of one channel have the same h_{FE} ratings.

4. If the TUNED lamp does not turn off when you touch the tuning knob, this may be due to strong signals generated by a nearby MW or SW broadcasting station. In this case, adjust the frequency of oscillator coil with L201 until the TUNED lamp turn off.

SPEAKER FUSE

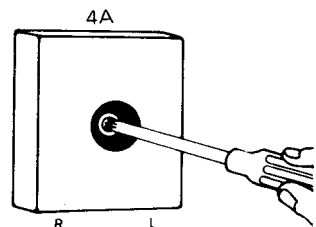

5. REMOVAL OF THE FRONT PANEL

- 1) Remove four screws holding top cover and chassis.
- 2) Remove two screws holding top cover and back panel.
- 3) Remove five screws holding front panel and front bracket.
- 4) Pull out all control knobs.

6. REMOVAL OF THE DIAL GLASS

- 1) Remove four screws holding dial glass and front panel.

NOTES: The dial glass has been mounted by applying an 800gr torque to the screws. If the dial glass is removed during repairs, and a torque driver is available, apply 800gr torque to the screws when replacing. If, however, a torque driver is not available, simply tighten the screws by hand.

When replacing the dial glass, insert all relevant component parts in accordance with the cross-sectional diagram.

7. REPLACEMENT OF INDICATOR LAMPS

All indicator lamps are linked to their respective lamp covers. So when replacing, remove the defective lamp from the front bracket with its cover in place.

8. REPLACING THE METER

- 1) Remove the top cover and the front panel.
- 2) Remove the two screws securing the illumination bracket and front bracket.
- 3) Remove the pointer ass'y from the front bracket.
- 4) Remove the 2 sets of screws securing the left and right lamp covers and dial plate covers to the front bracket.
- 5) Move the front panel out, keeping the dial plate cover held against the dial plate, and remove the 2 (left and right) lamp PC boards. Then remove the dial plate from the drive shaft.
- 6) Remove the 3 screws securing the front cover to the back plate.
- 7) The top sides of the meter covers are fastened to the back plate by adhesive tape. Remove this tape, taking care not to jar or knock the meters.

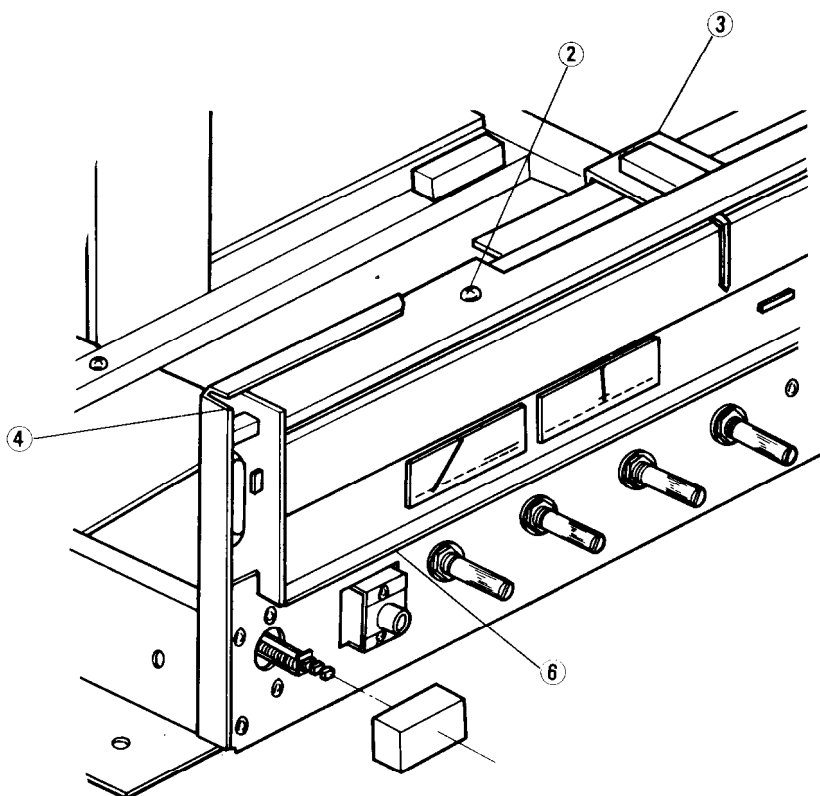

COMPONENT LOCATION

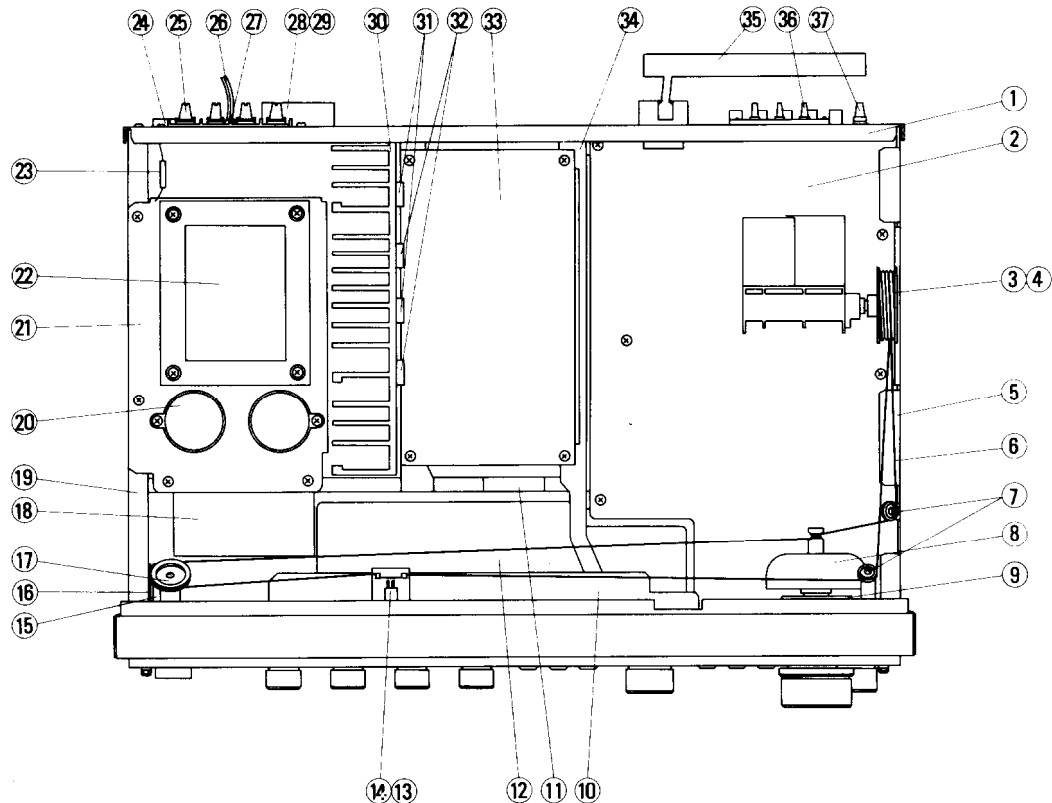

COMPONENT LOCATION-PARTS LIST

REF. NO.	CIRCUIT NO.	PARTS NO.	DESCRIPTION	REF. NO.	CIRCUIT NO.	PARTS NO.	DESCRIPTION
1	A081	27120114	Back panel	20	C908, C909	3504107	8,200 μ F, 50V, Elect. capacitor
2		13719570	NARFE-470, AM/FM tuner and equalizer ampli. p.c.b.	21	A060	27130125	Bracket, transformer
3	A075	27200019	Dial drum	22		230236	NPT-639D, Power transformer
4	A077	273803	SP-14A, Spring for dial drum	23	R801	431523355	3.3M Ω , 1/2W, Solid resistor
5	A035	27115030	Side bracket	24	P901, P902	25050008A	S-I6432, AC outlet
6	A078	273903	200mm, Dial cord	25	P805, P806	25060026	NTM-4PRMN03, Speaker terminal
7	A005	27185002	DP-16N, Dial pulley	26	W901	253072	AS-UC, Power supply cord
8	A002	27205013	Drive shaft	27	W901a	270025	SR-3P-4, Strainrelief
9	A003	27300071	Bearing	28	F501, F601	252014	4A-T, Speaker protector fuse
10	A001	27110056	Front bracket	29	F501a, F601a	25050004	Fuseholder with cover
11		250130	T-4461, Terminal	30	A070	27160035	Radiator
12		13719571	NAAF-471, Preampli. p.c.b.	31	Q505, Q605	2200822	2SD718 (R) Power ampli.
13	PL808	210044	PL8V0.05AW-3, Pointer lamp			2200823	2SD718 (O) transistor
14	A012	27220009	Pointer slider ass'y	32	Q506, Q606	2200832	2SB688 (R) Power ampli.
15	S901	25035047	NPS-111L12P, Power switch			2200833	2SB688 (O) transistor
16	C951	3504012	0.01 μ F, 125V, UL capacitor	33		13719572	NADA-472, Power ampli. p.c.b.
17	A004	27185001	DP-26N, Dial pulley	34	A046	27130126A	Bracket S
18		13719573	NAPS-473, Rectifier p.c.b.	35		232066	NMA-3012, AM bar antenna
19	A042	27115031	Side bracket	36	P804	25060020	NTM-3WPUN1, Antenna terminal
				37	P803	25060008	Ground terminal

EXPLODED VIEW

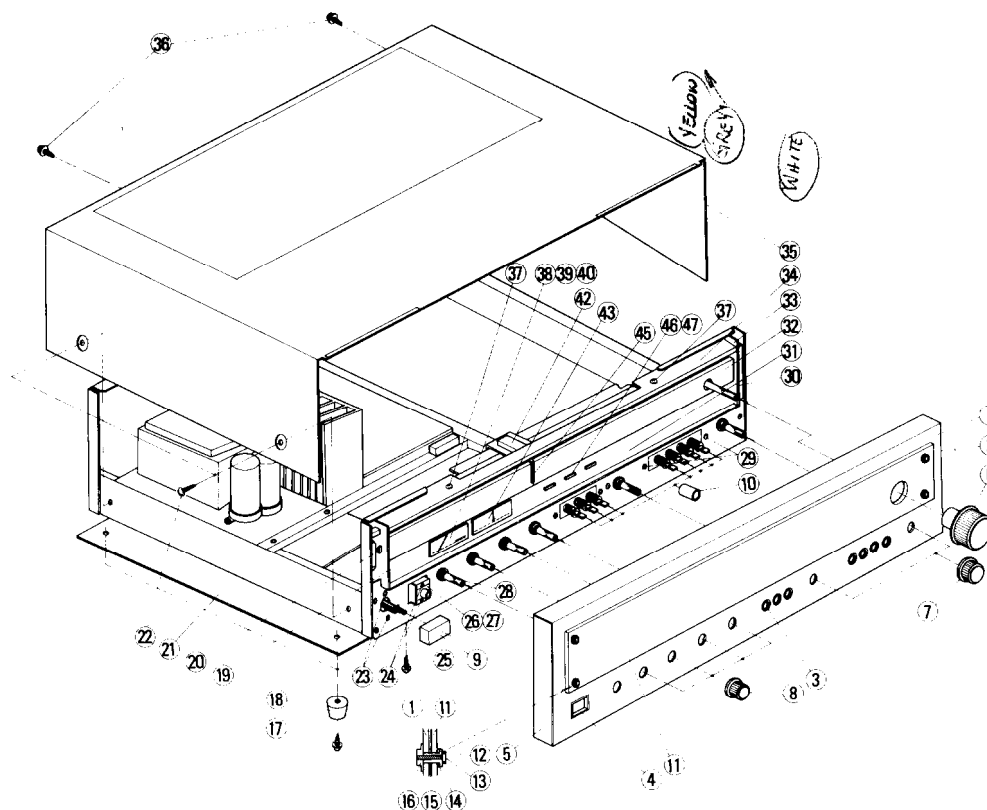

EXPLODED VIEW-PARTS LIST

REF. NO.	CIRCUIT NO.	PARTS NO.	DESCRIPTION	REF. NO.	CIRCUIT NO.	PARTS NO.	DESCRIPTION
		13719121-1	Front panel ass'y (1-5)	25	A602	831130082	3STW+8BQ, Screw
1	A501	27210095	Front panel	26	P807	25045018	LJ-100H, Stereo headphone jack
2	A502	28125048	End cap R	27	R528, R628	441623314	330Ω, 1W, Metal oxide film resistor
3	A509	27267026	Guide, push switch	28	S810	25030098	NRS-144-30Y, Speaker selector switch
4	A508	27267027	Guide, power switch	29		82113006	3P+6F-N, Screw
5	A503	28125049	End cap L	30		27300113	Lamp cover
6	A801	28320242	Tuning knob	31	A010	28133007	Back plate
7	A802	28320238	Volume knob	32	A013	28130063	Dial plate
8	A803	28320237	Tone knob	33	A016	27300103	Dial plate cover
9	A804	28320235	Power knob	34	A011	27240015	Illumination bracket
10	A805	28320239	Push knob	35	A351	28184037	Top cover
11	A504	28191024	Dial glass	36	A353	834430102	3STS+10BQ(BC), Tapping screw
12	A505	27270014	Spacer	37		834430102	3STS+6BQ Screw
13	A506	27300038A	Screw	38	M102	243085	NIND-0500S85, Strength meter
14	A512	870052	Washer	39	PL803, PL804	210041	PL8V0.15AW-2, Meter illumination lamp
15	A511	870051	Washer	40	A007	27300114	Cushion
16	A507	86213010	WN3×10FN, Nut	42	A022	28168002	Pointer cover
17	A605	831130162	3STW+16BQ, Screw	43	M101	243084	NIND-0250S84, Center meter
18	A604	280379	Leg	45	A009	28165042	Pointer
19	A015	27300102	Dial plate cover	46	A017	28198512	Facet
20		13719574	NAPL-474, Dial illumination p.c.b.	47	PL805-PL807	210040	PL12V 30mV, Stereo/Locked/Tuned indicator lamp
21	A600	27170041	Bottom board				
22	A352	838440109	4TTB+10C (BC), Screw				
23	A028	834130062	3STS+6BQ, Screw				
24	A023	801105	8W3P+6FN, Screw				

ALIGNMENT PROCEDURES

INSTRUMENTS REQUIRED

1. DC Voltmeter
2. AM Sweep Generator
3. AM/FM Signal Generator
4. AC VTVM
5. Oscilloscope
6. Monitorscope
7. Distortion Analyzer
8. Stereo Modulator
9. Frequency Counter

GENERAL ALIGNMENT CONDITIONS

1. Signal input should be kept as low as possible.
2. Standard modulation is 400Hz 30% (AM), 1kHz 100% (FM MONO), pilot 9% sub and main 91% (FM STEREO).
3. Standard knob position
 - SPEAKERS A
 - BASS, TREBLE & BALANCE Center
 - HIGH FILTER OFF
 - MODE STEREO
 - DE-EMPHA NORMAL
 - LOUDNESS OFF
 - MUTING LOCK OFF
 - TAPE 1, 2 OFF (SOURCE)

(1) IDLING CURRENT ADJUSTMENT

Connect the DC Voltmeter between ID and CT terminals.
 Adjust the voltage to $20 \pm 5\text{mV}$ with R513 (Left channel) *R515*
 Adjust the voltage to $20 \pm 5\text{mV}$ with R613 (Right channel) *R615*

NOTES: Adjust after switching on for 10 minutes.

Open load VOLUME Minimum TAPE MONITOR-1 ON

(2) AM IF ALIGNMENT

1. Set SELECTOR switch to AM.
2. Set radio dial to quiet point.

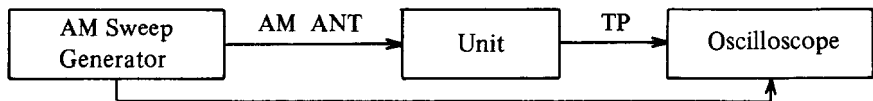

Set signal	Adjust	Oscilloscope	Remarks
455kHz	X103	Maximum Symmetrical Response	Usually not necessary to adjust

(3) AM RF ALIGNMENT

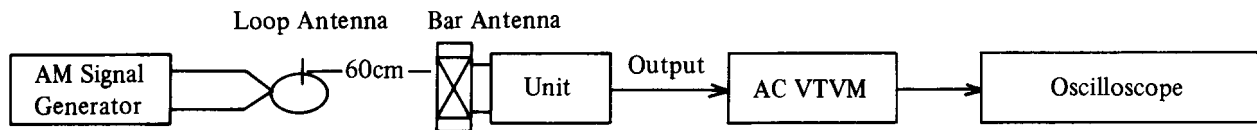

Step	Set Signal	Set Radio Dial	Adjust	VTVM reading	Remarks
1	515kHz 400Hz 30%	Lower end (515kHz)	L103	Maximum	Repeat step 1 and 2 as necessary
2	1680kHz 400Hz 30%	Upper end (1680kHz)	TC002	Maximum	
3	600kHz 400Hz 30%	600kHz	L007	Maximum	Repeat step 3 and 4 as necessary
4	1400kHz 400Hz 30%	1400kHz	TC001	Maximum	

(4) FM FRONT END ALIGNMENT

1. Set SELECTOR switch to FM.
2. Connect FM Signal Generator to 300-ohm antenna terminals.

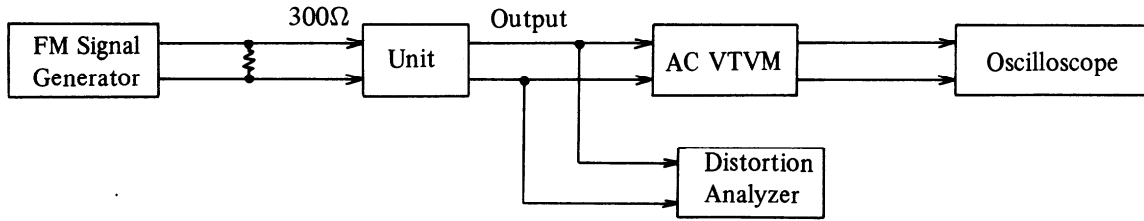

Step	FM Signal Generator	Dial to set	Adjust	Output Indicator	Adjust for	Remarks
1	No signal	Quiet Point	T101 Bottom	Tuning Indicator	Center	Repeat Steps 1 and 2 as necessary
2	98MHz 65dBf 1kHz 75kHz div.	98MHz	T101 Top	Distortion Analyzer	Minimum	
3	90MHz 65dBf 1kHz 75kHz div.	90MHz	L004	Tuning Indicator	Center	Repeat Steps 3 and 4 as necessary
4	106MHz 65dBf 1kHz 75kHz div.	106MHz	TC005		Center	
5	90MHz 20dBf 1kHz 75kHz div.	90MHz	L001 L002	AC VTVM or Oscilloscope	Maximum	Repeat Steps 5 and 6 as necessary
6	106MHz 20dBf 1kHz 75kHz div.	106MHz	TC003 TC004		Maximum	
7	98MHz 65dBf 1kHz 75kHz div.	98MHz	T001	Distortion Analyzer	Minimum	

(5) SERVO LOCKED CIRCUIT ALIGNMENT

FM signal generator	Dial to set	FM muting switch	Adjust	Output Indicator	Adjust for
98MHz 65dBf 1kHz 75kHz div.	98MHz	Off	Tuning	Center Meter	Center
		On	R143		Center

(6) MULTIPLEX ALIGNMENT

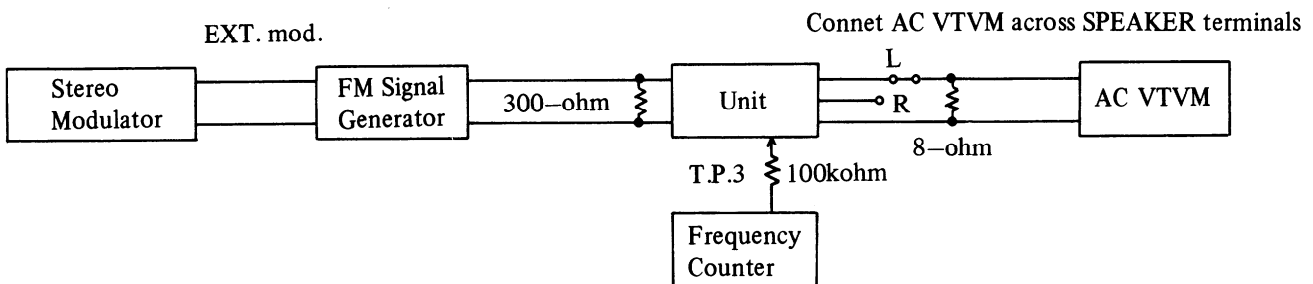

Step	FM Signal Generator	Stereo Modulator	Dial to set	Adjust	Output Indicator	Adjust for	Remarks
1	98MHz no mod. 65dBf	—	98MHz	R131	Frequency Counter	19000±19Hz	
2	STEREO INDICATOR should light up when stereo program is being received.						
3	98MHz EXT. Mod. 65dBf	Pilot Sig. 9% Main & Sub Sig. 1KHz Lch 91%	98MHz	R126	AC VTVM Right ch.	Minimum	Repeat Steps 3 & 4 as necessary
4	Same as above	Pilot Sig. 9% Main & Sub Sig. 1KHz Rch 91%	98MHz	R126	AC VTVM Left ch.	Minimum	

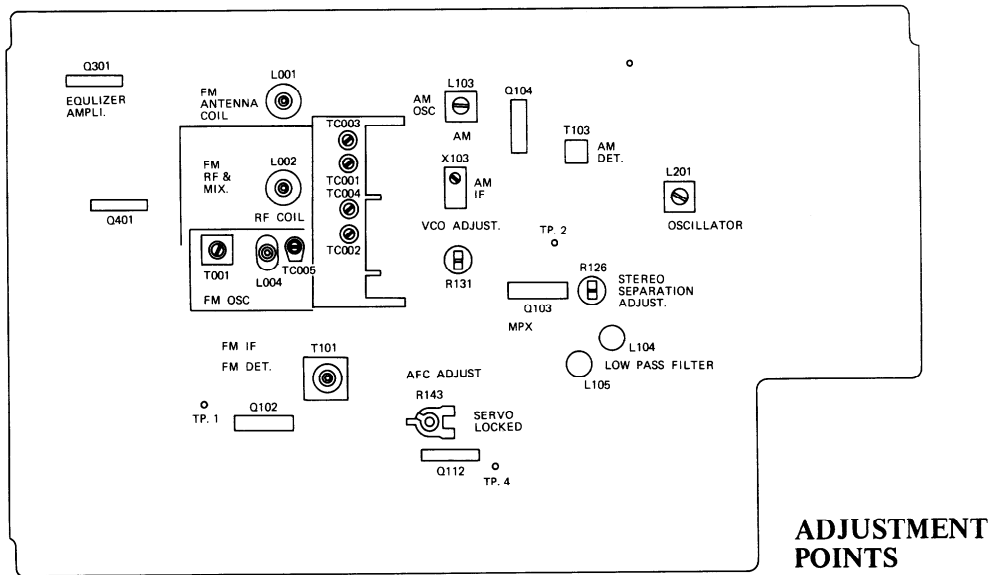

STRINGING DIAGRAM

1. Close the variable capacitor complete and tie the dial cord to the spring of the drum.
2. Thread the dial cord in the direction of arrow from (1) to (3) and wind the dial cord three turns around the tuning shaft clockwise.
3. Wind the dial cord 1½ turns around the dial drum.
4. Thread the dial cord to the dial pulley 3.

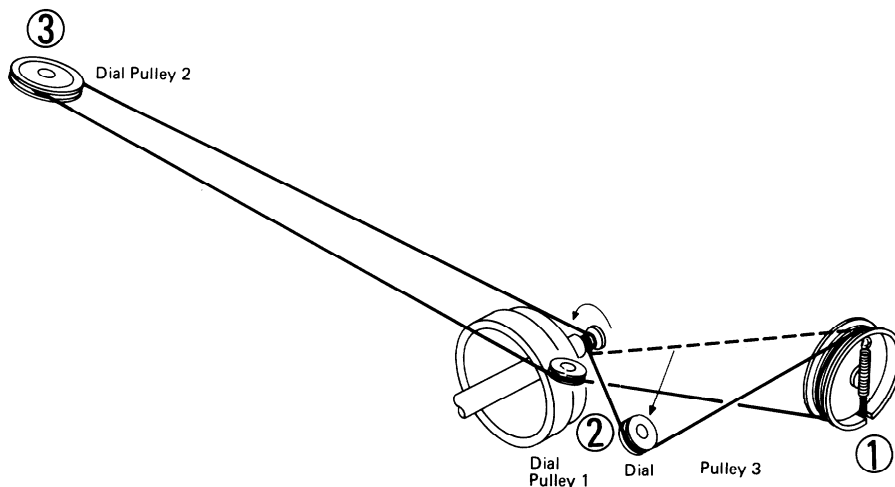

AM/FM TUNER AND EQUALIZER AMP. PC BOARD VIEW FROM BOTTOM SIDE

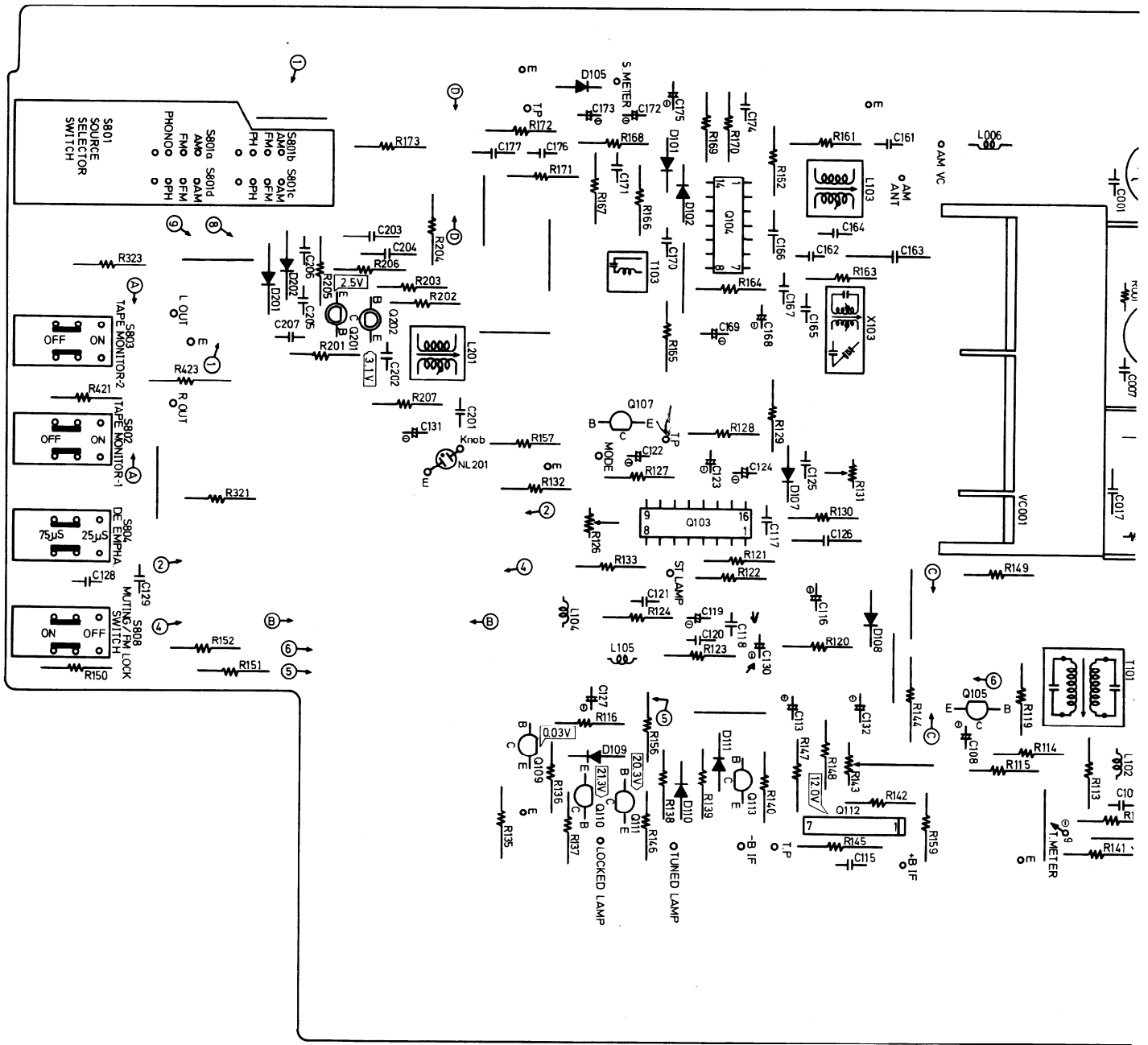

HA-1137 BLOCK DIAGRAM

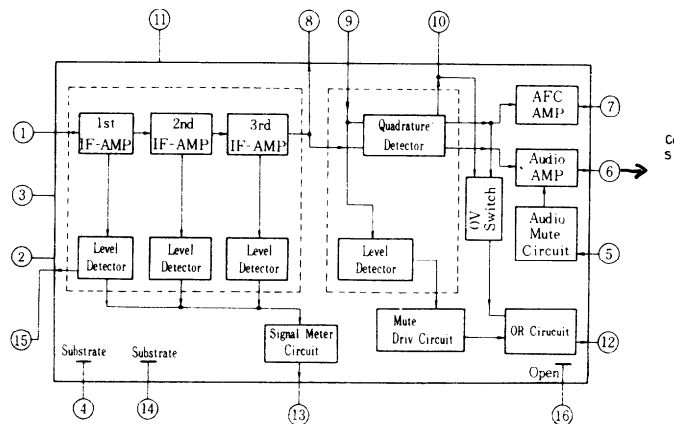

BA-1320 BLOCK DIAGRAM

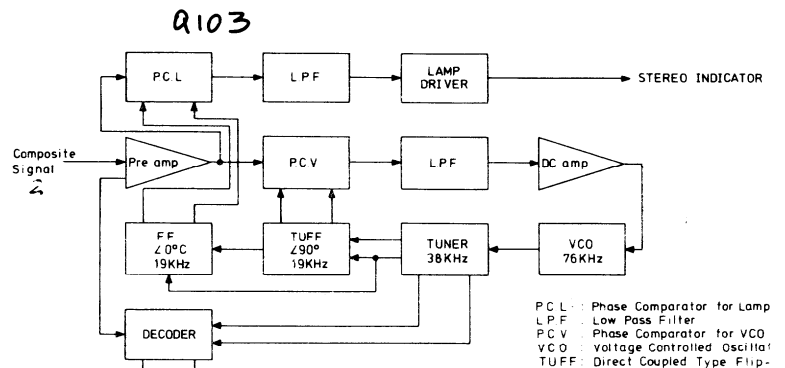

PREAMP. PC BOARD VIEW FROM BOTTOM SIDE

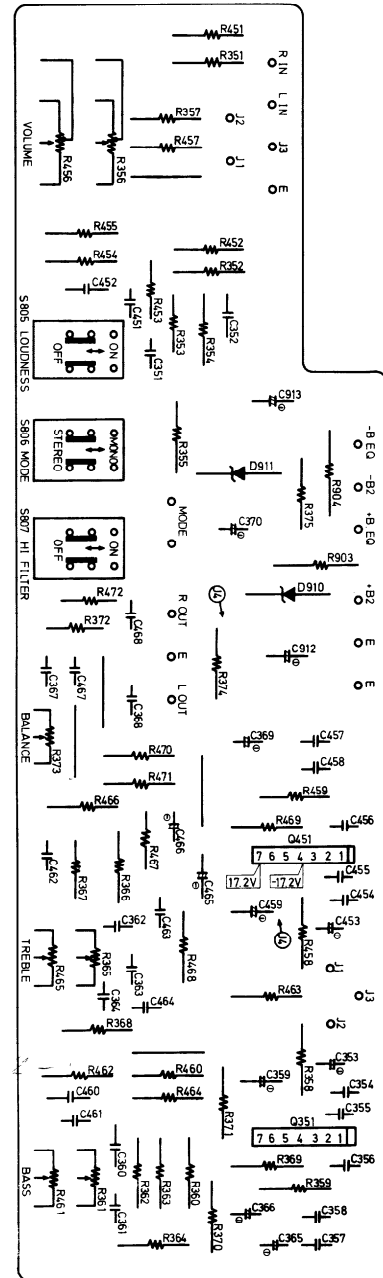
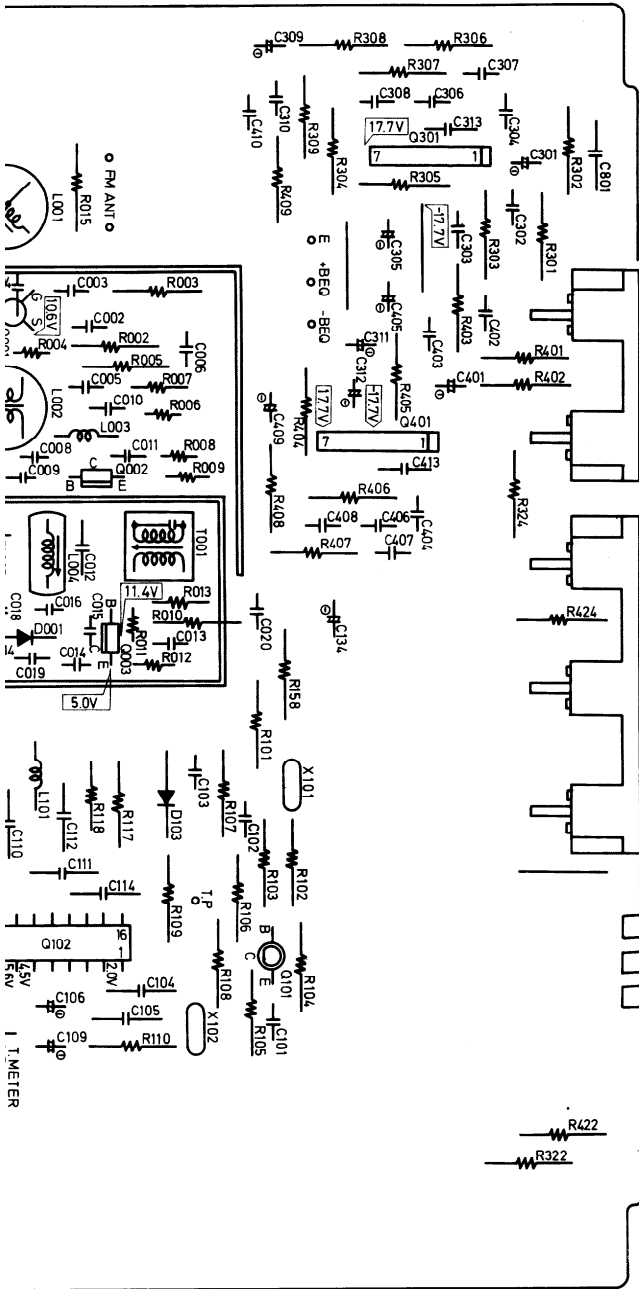

HA-1151 EQUIVALENT CIRCUIT

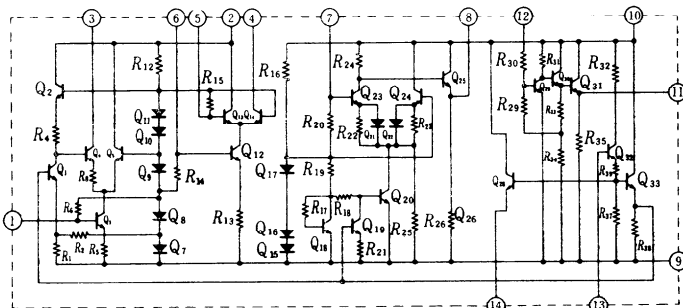

VOLTAGE
MEASURED WITH
V.T.V.M
(NO INPUT SIGNAL)

PARTS LIST

Q701, Q702	2210085 or 2210086	28C733 (GR) or T.K.C
Q703	2210670 or 2210671	28C1681 (O-1) or T.K.C
Q901	2200013 or 2200014	28D235 (O) or Rectifier
Q902	2211254 or 2211255	28C1815 (Y) or Rectifier

DIODES

D501, D907	223802 or 223849	1S1885 or ERB12-01
D502	223921	WZ-210, Zener
D701	223123	1S2472
D702	223124	1S2473

CAPACITORS

C501, C601	352780221	2.2μF, 50V, Elect.
C504, C604	352734701	47μF, 10V, Elect.
C508, C608	352784701	47μF, 50V, Elect.
C511, C611	352784711	470μF, 50V, Elect.
C512, C513	352780471	4.7μF, 50V, Elect.
C612, C613		
C703	352752211	220μF, 25V, Elect.
C704	352782211	220μF, 50V, Elect.
C915	352744701	47μF, 16V, Elect.
C916	352742211	220μF, 16V, Elect.

RESISTORS

R511, R611	4000003	D22A, Thermistor
R515, R615	5225026	N10HR470BD, Idling current adjustment
R517, R617	441622224	2.2kΩ, 1W, Metal oxide film
R522, R523	48394794	0.47Ω, 3W, Cement
R622, R623		

RADIATOR

L501, L601	27160029	RAD-07, Radiator
------------	----------	------------------

COILS

L501, L601	231001	S-1.3B
------------	--------	--------

RECTIFIER PC BOARD (NAPS-473) – PARTS LIST

CIRCUIT NO.	PARTS NO.	DESCRIPTION
-------------	-----------	-------------

DIODES

D901~D904	223841	GP-30G
D905, D906	223806	1S1886
D908, D909	223850 or 223848,	ERB12-02 or GP08P,
	223802 or 223849	1S1885 or ERB12-01
	223910 or 223963	WZ-120 or RD-12EB

CAPACITORS

C905	352782211	220μF, 50V, Elect.
C910, C911	352762211	220μF, 35V, Elect.
C914	352754711	470μF, 25V, Elect.
C917	352742211	220μF, 16V, Elect.

METAL OXIDE FILM RESISTORS

R901, R902	441623614	360Ω, 1W
R912	441621524	1.5kΩ, 1W
R913	441721824	1.8kΩ, 2W

FUSE HOLDER

F901	252049	4A ST-6, AC
------	--------	-------------

DIAL ILLUMINATION PC BOARD (NAPL-474) – PARTS LIST

F801	210039A	300mA, 8V, Dial illumination lamp
------	---------	-----------------------------------

BLOCK DIAGRAM

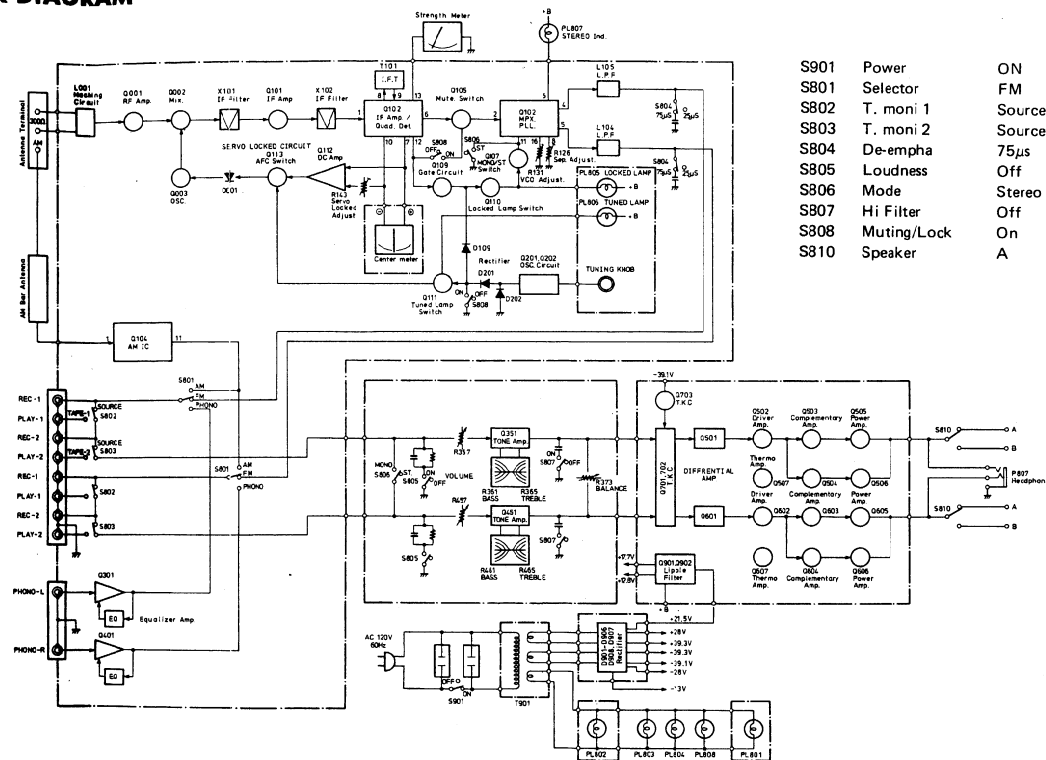

S901	Power	ON
S801	Selector	FM
S802	T. moni 1	Source
S803	T. moni 2	Source
S804	De-empha	75μs
S805	Loudness	Off
S806	Mode	Stereo
S807	Hi Filter	Off
S808	Muting/Lock	On
S810	Speaker	A

NOTES:

CAPACITOR

LL: Low leakage current type electrolytic capacitor
 ST: Polystyren film capacitor
 When replacing differential amplifier or push-pull amplifier transistors, be sure that transistors of one channel have same h_{FE} ratings.

CIRCUIT DESCRIPTION

1. Muting Circuit

The Quadrature detector IC incorporates an IF level detector circuit (output at pin 12). If the IF signal level drops below the muting level, pin 12 will be switched to high level, turning Q105 on. Consequently, the detector output signal will be cut off before it can be applied to the multiplex IC. When, on the other hand, the IF signal level is higher than the muting level, the Q102 pin 12 will be switched to low level, turning Q105, and Q109 off. Q110 will therefore turn on, followed by the LOCKED lamp turning on.

2. Servo Locked Circuit

The DC potential difference across both ends of the tuning meter (corresponding to the DC portion of the ratio detector output) is amplified by about 30dB by the Q112 operational amplifier in order to increase the AFC control capacity.

3. AFC Switching Circuit

In order to ensure accurate tuning, the AFC circuit is automatically disconnected as soon as the tuning knob is touched. The Q202 oscillator circuit generates a signal of approximately 6MHz which is amplified by Q201, and full-wave rectified by D201/D202. The DC portion of this signal is then employed in switching Q113 on and off. When tuned away from broadcasting stations, the Q109 collector will be at low level, thereby switching the Q111 base voltage to low level also. Q113 will consequently turn on, and the AFC circuit turn off. When tuned into a station, however, the Q111 base voltage will be switched to high level, thereby turning Q111, and the Tuned Lamp on. Q113 will turn off, and the AFC circuit turn on. If the tuning knob is then touched, the oscillator circuit will cease to generate signals, and the AFC circuit will turn off. Furthermore, the NL-201 neon lamp serves to prevent the destruction of transistors due to the presence of static electricity.

PACKING PROCEDURES

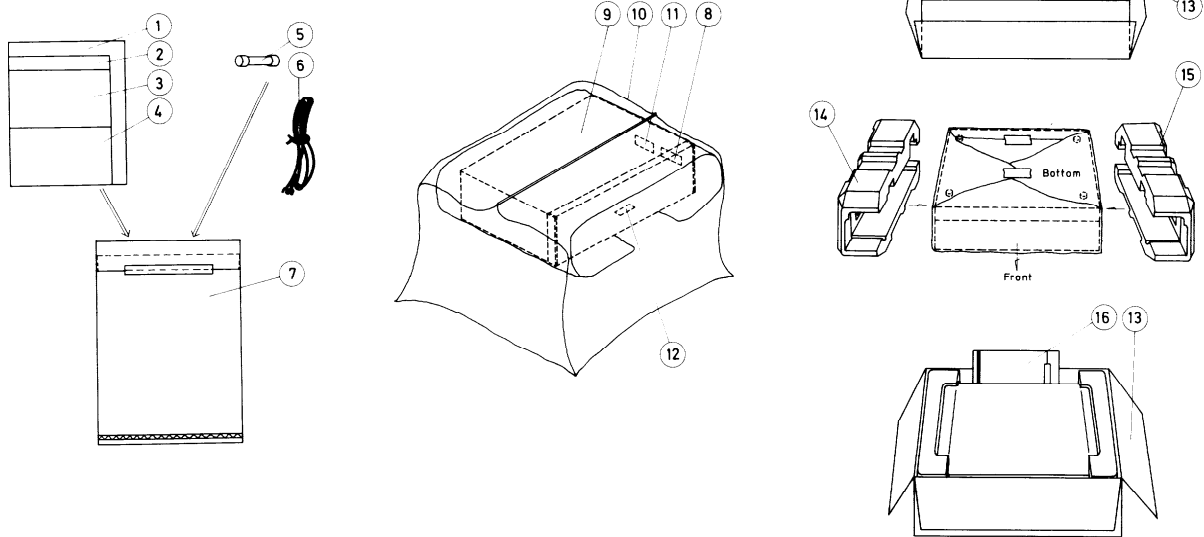

PARTS LIST

REF. NO.	CIRCUIT NO.	PARTS NO.	DESCRIPTION
1	A881	29340257	Instruction manual
2	A889	29358001	Service station list
3	A885	29355046	Caution card, warranty
4	A882	29365003	Warranty card
5	A902	252014	4A-T, Fuse
6	A901	292064	5059-01, FM antenna
7	A861	29100006	Poly bag
8	A886	29360197	Label, cabinet composite
9	A855	290093	500x1,200, Protection sheet
10	A854	29100027A	850 x 650mm, Poly bag
11	A884	282969	Caution label
12	A883	293041	Caution card
13	A851	29050185	Carton box
14	A852	29090279	Pad R
15	A853	29090278	Pad L
16		13719119	Accessory bag

ONKYO CORPORATION

International Division: No. 24 Mori Bldg., 23-5, 3-chome, Nishi-Shinbashi, Minato-ku, Tokyo, Japan.
Telex 2423551 ONKYO J. Phone 03-432-6981

ONKYO U.S.A. CORPORATION

Eastern Office

42-07 20th Avenue, Long Island City, New York 11105, U.S.A. Phone (212) 728-4639

Midwest Office

935 Sivert Drive, Wooddale, Illinois 60191, U.S.A. Phone (312) 595-2970