

T-65-09



PLESSEY
Semiconductors

SL440 POWER CONTROL CIRCUIT

The SL440 is a versatile integrated circuit designed to provide variable-phase control of triacs and other power switching devices in a variety of domestic and industrial applications. The basic elements of the SL440 are shown in Fig.2.

An external timing capacitor, C_T , connected to pin 14 is discharged during positive and negative half cycles of the driving waveform (typically 50Hz), at a constant rate which is proportional to the output of the servo amplifier (pin 13). When the charge reaches an internally-defined level, the conduction control circuit generates a $50\mu s$ (typ.) firing pulse (pin 1) to trigger the triac. The crossover detector resets the timing cycle when the driving waveform passes through zero, at which point C_T is recharged rapidly. The servo amplifier thus controls the conduction time of the triac, and hence the power delivered to the load.

If the inhibit input (pin 4) is taken below +5V (e.g. to pin 11) the conduction control circuit action is over-riden and the firing pulses are inhibited. This facility can be used in conjunction with the current limit detector, by driving the AC input terminals (pins 5 and 10) from a current transformer in

FEATURES

- Conduction Control
- Crossover Detector
- Servo Amplifier
- Internal Stabilised Supply (Available for External Circuitry)
- Total Power Shut-Down Facility
- AC Load Current Limitation

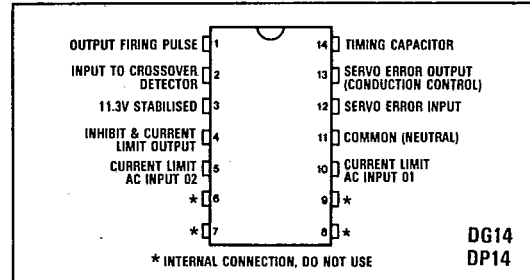

Fig.1 Pin connections (top view)

series with the load. If a load resistor is connected from pin 4 to the stabilised supply (pin 3), a DC voltage, inversely proportional to the AC load current, appears on pin 4. This is applied to the variable delay pulse generator as soon as the internally defined threshold voltage (approximately 5V) exceeds it, and so limits the load current.

APPLICATIONS

- Lamp Dimmers
- Automatic Lamp Faders
- Motor Speed Control

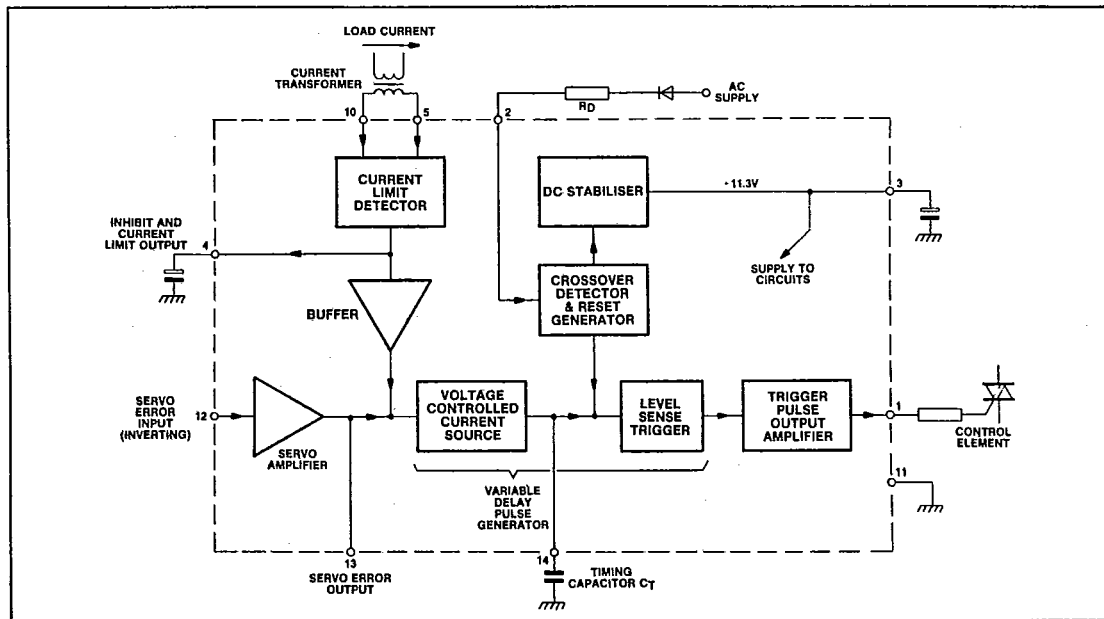

Fig.2 SL440 functional block diagram

T-65-09

ELECTRICAL CHARACTERISTICS
 Test conditions (unless otherwise stated):
 Tamb = +25°C

Characteristics	Value			Units	Conditions
	Min.	Typ.	Max.		
Firing pulse width		50		μs	Rectified AC
Max. pulse current	60	120		mA	
Current to pin 3	15		30	mA	
Voltage at pin 3 (internally stabilised)		11.3		+V	Typical application, gain = $\frac{R_L}{2k}$
Inhibit operating voltage (pin 4)	0		5	+V	
Static gain of servo amplifier		75		-	
Current limit input threshold		±0.7		V	

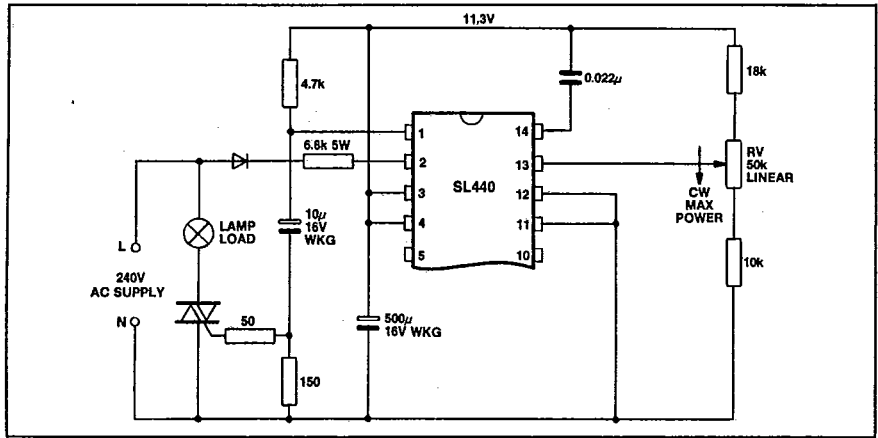

Fig.3 Lamp dimmer using minimum components

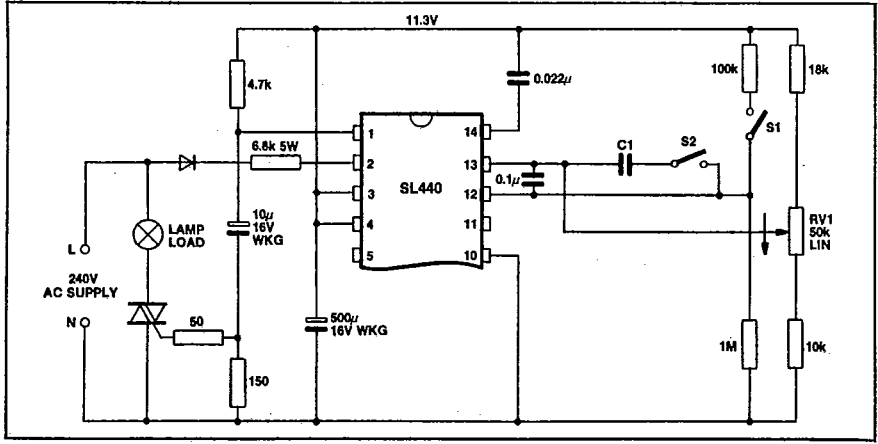

Fig.4 Automatic lamp fading circuit

APPLICATION NOTES

A simple, manually-controlled, lamp dimmer circuit is shown in Fig.3. In this application, the servo amplifier is not used; proportional control of lamp brightness is effected by the voltage applied via RV1 to the servo amplifier output (pin 13) which is internally connected to the conduction control circuit.

A more sophisticated use of the SL440 is shown in Fig.4 an

automatic lamp fading circuit which has applications in a variety of domestic environments. The circuit is used as follows: with S1 and S2 both open, the level of brightness is directly controlled by the setting of RV1. When S1 is closed, the positive voltage applied to pin 12 causes firing pulses to be produced at a conduction angle approaching 180° (Fig.5) and the lamp brightness is maximum. When S2 is closed and

S1 is opened, the servo amplifier acts as an integrator due to the Miller action of C1 and the lamp brightness fades progressively to the level previously set by RV1. The fade rate is determined by the choice of C1: for example, a 250 microfarad capacitor will result in a subjectively imperceptible fade rate of 20-30 minutes.

Fig.6 shows the SL440 used in a motor speed control circuit. The DC motor/tacho-generator is used in a velocity servo loop in which motor velocity is linearly proportional to the setting of RV1. RV2 controls the maximum motor current in the range 1 to 10A.

OPERATING NOTES

In applications where RF radiation is a problem, it is recommended that the filter circuit shown in Fig.7 be used.

Where the SL440 is used for domestic light dimming, or in other applications where the power dissipated in the dropping resistor R_D is considered excessive, the series rectifier and dropping resistor can be replaced by the circuit shown in Fig.8. The series capacitor, together with the low impedance at pin 3, provides a degree of RF filtering at the AC supply terminals.

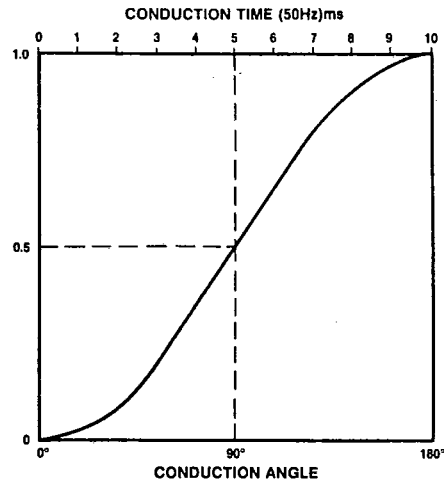

Fig.5 Triac conduction angle v. sinewave load power

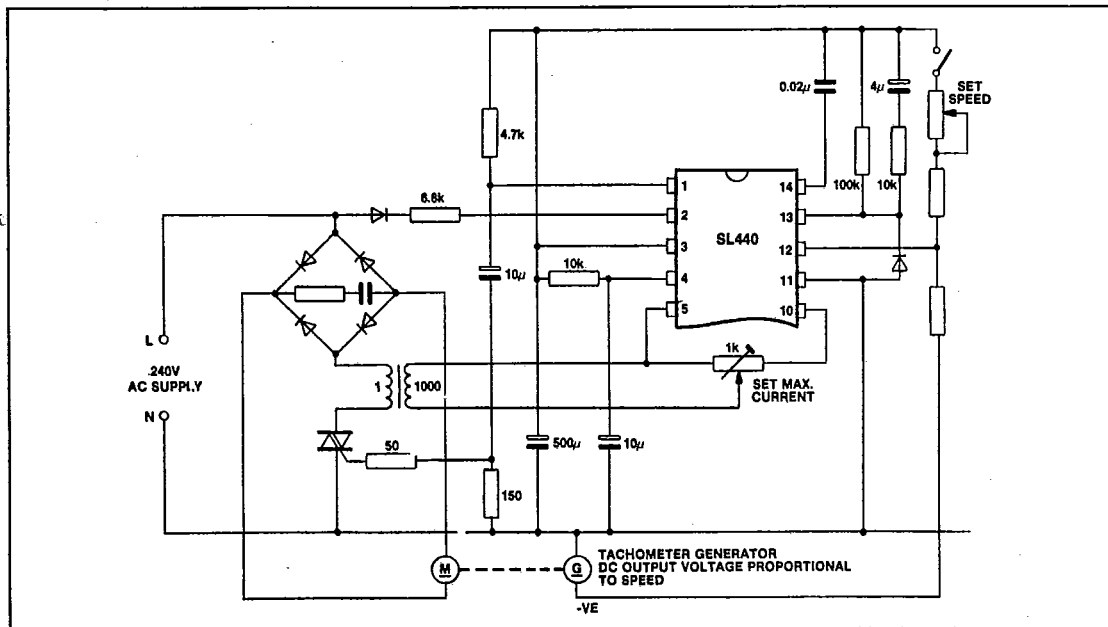

Fig.6 Servomotor control with motor current limiting

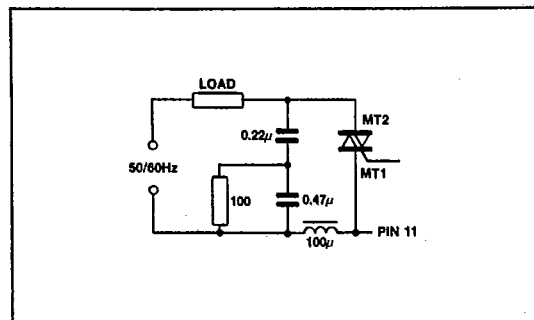

Fig.7 RF filter for loads less than 100W or inductive. For load of 100W and above, use 100µH and 0.1µF only.

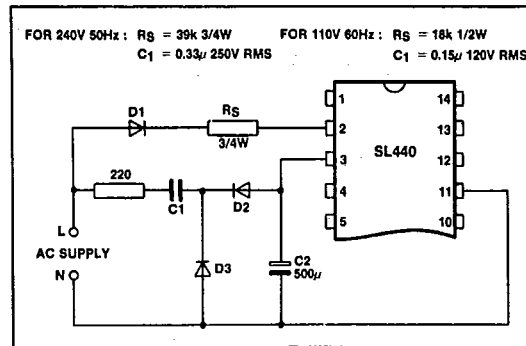

Fig.8 Low loss power supply

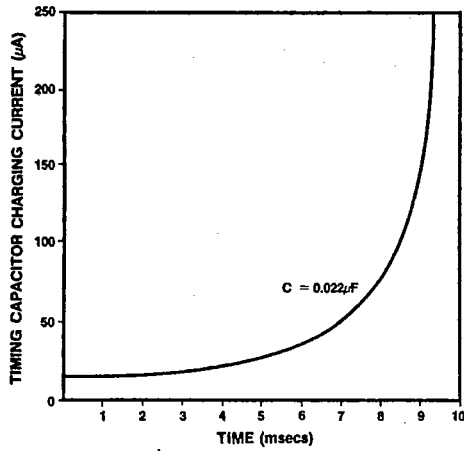

Fig.9 Triac conduction time v. capacitor charging current

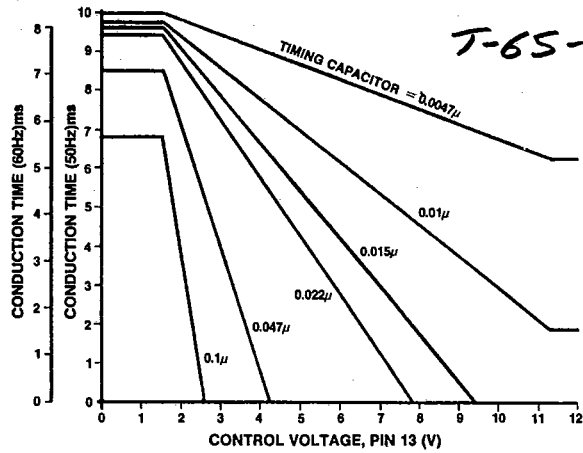

Fig.10 Triac conduction time v. servo amplifier output (demonstrating linear relationship)

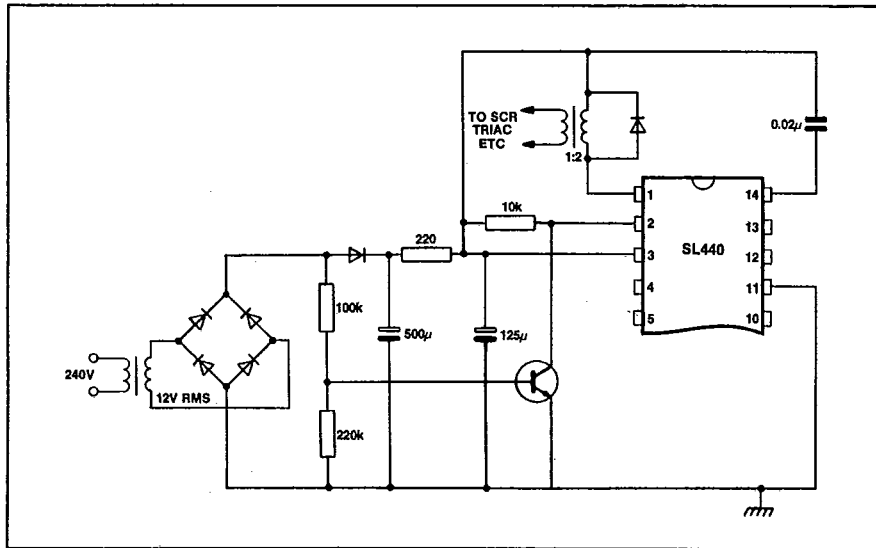

Fig.11 Fully isolated supply operation of SL440, featuring full-wave crossover detection for symmetrical timing. Additional SL440s can be powered via separate 220Ω feed resistors, synchronising being achieved by connecting pin 2 of each SL440 to the collector of the common sync. transistor TR1.

ABSOLUTE MAXIMUM RATINGS

Storage temperature	-55° C to +125° C
Operating temperature	-10° C to +65° C
Package dissipation	600mW
Supply current to pin 2	200mA DC

NOTE

Where the SL440 is to be used in a device socket, care should be taken to ensure that the reservoir capacitor on pin 3 is discharged before inserting the device. Failure to observe this precaution may result in damage to the internal shunt stabiliser.

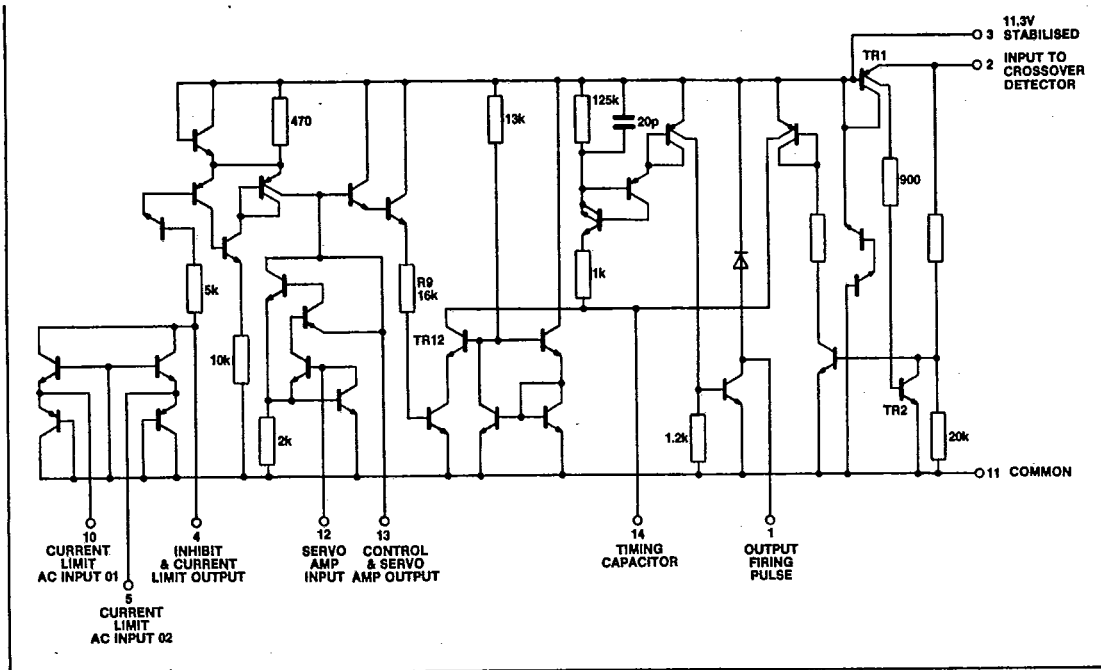

Fig.12 Circuit diagram of SL440

PACKAGE DETAILS

Dimensions are shown thus: mm (in)

