

LM10V332

Color STN LCD Module

(Model Number: LM10V332)

Specifications

Spec No.: LC99213A

Dated: May 31, 2002

NOTICE

This publication is the proprietary of SHARP and is copyrighted, with all rights reserved. Under the copyright laws, no part of this publication may be reproduced or transmitted in any form or by any means, electronic or mechanical for any purpose, in whole or in part, without the express written permission of SHARP. Express written permission is also required before any use of this publication may be made by a third party.

The application circuit examples in this publication are provided to explain the representative applications of SHARP's devices and are not intended to guarantee any circuit design or permit any industrial property right or other rights to be executed. SHARP takes no responsibility for any problems related to any industrial property right or a third party resulting from the use of SHARP's devices, except for those resulting directly from device manufacturing processes.

In the absence of confirmation by device specification sheets, SHARP takes no responsibility for any defects that occur in equipment using any of SHARP's devices, shown in catalogs, data books, etc. Contact SHARP in order to obtain the latest device specification sheets before using any SHARP's device.

SHARP reserves the right to make changes in the specifications, characteristics, data, materials, structures and other contents described herein at any time without notice in order to improve design or reliability. Contact SHARP in order to obtain the latest specification sheets before using any SHARP's device. Manufacturing locations are also subject to change without notice.

Observe the following points when using any device in this publication. SHARP takes no responsibility for damage caused by improper use of the devices.

The devices in this publication are designed for use in general electronic equipment designs, such as:

- Automotive auxiliary information display
- Automotive audio visual equipment

The appropriate design measures should be taken to ensure reliability and safety when SHARP's devices are used for equipment such as:

- Transportation control and safety equipment(i.e., aircraft, trains, automobiles, etc.)
- Traffic signals • Gas leakage sensor breakers
- Alarm equipment • Various safety devices etc.

SHARP's devices shall not be used for equipment that requires extremely high level of reliability, such as:

- Military and space applications • Nuclear power control equipment
- Medical equipment for life support

Contact a SHARP representative, in advance, when intending to use SHARP's devices for any "specific" applications other than those recommended by SHARP.

Contact and consult with a SHARP representative if there are any questions about the contents of this publication.

| | | |
|-------------------------------|--|--|
| PREPARED BY: _____ DATE _____ | <h1>SHARP</h1> <p>LIQUID CRYSTAL DISPLAY GROUP SHARP CORPORATION</p> <h2>SPECIFICATION</h2> | SPEC No. LC99213A |
| APPROVED BY: _____ DATE _____ | | FILE No. _____ |
| | | ISSUE JUL. 12.1999 |
| | | PAGE 26 Pages |
| | | REPRESENTATIVE DIVISION |
| | | ENGINEERING DEPARTMENT 1 DUTY LCD DEVELOPMENT CENTER DUTY LIQUID CRYSTAL DISPLAY GROUP |

DEVICE SPECIFICATION for
Passive Matrix Color LCD Module
(640×480 dots)

Model No.

LM10V332

CUSTOMER'S APPROVAL

DATE _____

BY _____

PRESENTED
for BY *A. Kawamori*
M.Ise
DEPARTMENT GENERAL MANAGER
ENGINEERING DEPARTMENT I
DUTY LCD DEVELOPMENT CENTER
DUTY LIQUID CRYSTAL DISPLAY GROUP
SHARP CORPORATION

| ● Contents | Page |
|---|------|
| 1.Application | 2 |
| 2.Construction and Outline | 2 |
| 3.Mechanical Specifications | 3 |
| 4.Absolute Maximum Ratings | 3 |
| 4-1.Electrical absolute maximum ratings | 3 |
| 4-2.Environment Conditions | 4 |
| 5.Electrical Specifications | 5 |
| 5-1.Electrical characteristics | 5 |
| 5-2.Interface signals | 6 |
| 6.Module Driving Method | 12 |
| 6-1.Circuit configuration | 12 |
| 6-2.Display face configuration | 12 |
| 6-3.Input data and control signal | 12 |
| 7.Optical Characteristics | 14 |
| 8.Characteristics of Backlight | 19 |
| 9.Supply voltage sequence condition | 21 |
| 10.Cautions | 22 |
| 11.Applicable inspection standard | 25 |
| Warning | 25 |

1. Application

This data sheet is to introduce the specification of LM10V332, Passive Matrix type Color LCD module.

2. Construction and Outline

Construction: 640×480 dots color display module consisting of an LCD panel, PWB(printed wiring board) with electric components mounted onto, TCP(tape carrier package) to connect the LCD panel and PWB electrically, and plastic chassis with CCFT back light and bezel to fix them mechanically.

Signal ground(Vss) is connected with the metal bezel.

DC/DC converter is built in.

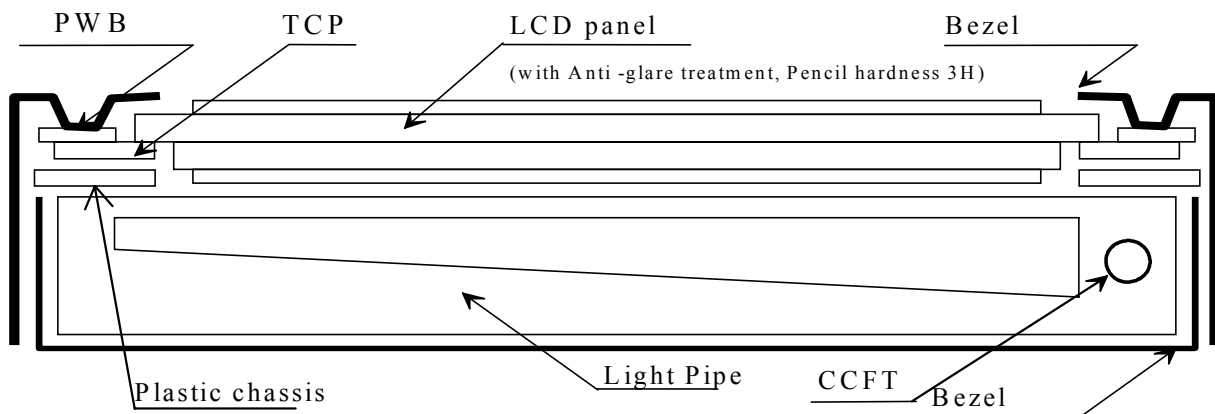

Outline :See Fig. 13

Connection :See Fig. 13 and Table 6

3. Mechanical Specification

Table1

| Parameter | Specifications | Unit |
|--------------------|-----------------------------------|------|
| Outline dimensions | 264±0.5(W)×193.6±0.5(H)×8.5MAX(D) | Mm |
| Bezel opening area | 215.2±0.3(W)×162.4±0.3(H) | mm |
| Display format | 640(W)×480(H) full dots | mm |
| Dot size | 0.09×RGB(W)×0.31(H) | — |
| Dot spacing | 0.02 | mm |
| *1 Base color | Normally black *2 | — |
| Weight | Approx. 450 | g |

*1 Due to the characteristics of the LC material, the colors vary with environmental temperature.

*2 Negative-type display

Display data “H” : ON → transmission

Display data “L” : OFF → light isolation

4. Absolute Maximum Ratings

4-1. Electrical absolute maximum ratings

Table 2

| Parameter | Symbol | MIN. | MAX. | Unit | Remark |
|-----------------------|----------------------------------|------|----------------------|------|----------|
| Supply voltage(Logic) | V _{DD} -V _{SS} | 0 | 6.0 | V | Ta=25 °C |
| Input voltage | V _{IN} | -0.3 | V _{DD} +0.3 | V | Ta=25 °C |

4-2.Environment Conditions

Table 3

| Item | Tstg | | Topr | | Remark |
|---------------------|---------|--------|---------|--------------------------------|-------------------------------------|
| | MIN. | MAX. | MIN. | MAX. | |
| Ambient temperature | -25 °C | +60 °C | 0 °C | \triangle +50 °C +40°C | Note 4) |
| Humidity | Note 1) | | Note 1) | | No condensation |
| Vibration | Note 2) | | Note 2) | | 3 directions(X/Y/Z) |
| Shock | Note 3) | | Note 3) | | 6 directions($\pm X \pm Y \pm Z$) |

Note 1) $T_a \leq 40$ °C 95 % RH Max.

$T_a > 40$ °C Absolute humidity shall be less than $T_a=40$ °C/95 % RH.

Note 2)

Table 4

| | | |
|-----------------|-----------------------------|----------------------|
| Frequency | 10 Hz~57 Hz | 57 Hz~500 Hz |
| Vibration level | - | 9.8 m/s ² |
| Vibration width | 0.075 mm | - |
| Interval | 10 Hz~500 Hz~10 Hz/11.0 min | |

2 hours for each direction of X/Y/Z (6 hours as total)

Note 3) Acceleration : 490 m/s²

Pulse width : 11 ms

3 times for each directions of $\pm X/\pm Y/\pm Z$

Note 4) As opt-electrical characteristics of LCD will be changed, dependent on the temperature, the confirmation of display quality and characteristics has to be done after temperature is set at 25°C and it becomes stable.

5. Electrical Specifications

5-1. Electrical characteristics

Table 5

Ta=25 °C

VDD= 5.0 V±10 %

| Parameter | Symbol | Conditions | Min. | Typ. | Max. | Unit |
|-------------------------|-----------------------------------|-------------------------------------|--------------------|--------------|-------------------|------|
| Supply voltage (Logic) | V _{DD} -V _{SS} | △Ta = 0~ 50 40°C(Note 1) | 4.5 | 5.0 | 5.5 | V |
| Contrast adjust voltage | V _{con} -V _{SS} | △Ta = 0~40 °C | 0.8 | 1.95 | 2.8 | V |
| Input signal voltage | V _{IN} | “H” level | 0.8V _{DD} | — | V _{DD} | V |
| | | “L” level | | | | |
| Supply current(Logic) | I _{DD} | Note 2) | — | △210 90 | △320 135 | mA |
| Power consumption | P _d | Note 2) | — | △1050 450 | △1600 680 | mW |
| Rush current(Logic) | I _{DD} | Ta=25°C,Note 1)-① | — | — | △2A×2 1A×2 | ms |
| | | Ta=25°C,Note 1)-② | — | — | △1A×10 0.5A×20 | μs |

Note 1) Under the following conditions.:Logic voltage(VDD) should be designed to supply following Inrush current.

- ①Immediately after the rise of V_{DD} .
- ②Under the situation that DISP signal is on and kept steady.

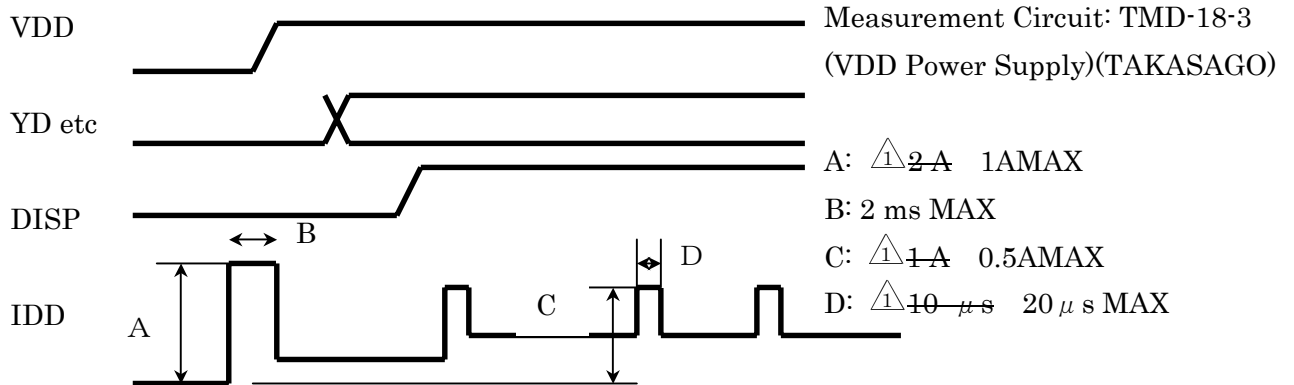

Note 2) Under the following condetions

V_{con}-V_{SS}: contrast max.(1.95V typ.)

V_{DD}-V_{SS}=5V,Frame frequency=120Hz, Display pattern : black/white stripe pattern.

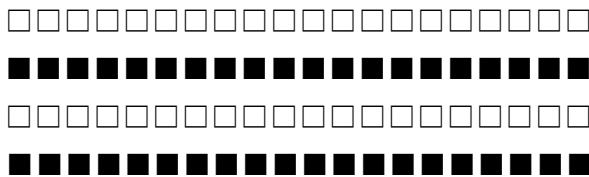

This value Is direct current.

5-2.Interface signals

● LCD

Table 6

| Pin No. | Symbol | Description | Level |
|---------|--------|--------------------------------|---------------|
| 1 | DL4 | Display data signal | H(ON), L(OFF) |
| 2 | VSS | Ground potential | - |
| 3 | DL5 | Display data signal | H(ON), L(OFF) |
| 4 | YD | Scan start-up signal | “H” |
| 5 | DL6 | Display data signal | H(ON), L(OFF) |
| 6 | LP | Input data latch signal | “H” → “L” |
| 7 | DL7 | Display data signal | H(ON), L(OFF) |
| 8 | VSS | Ground potential | - |
| 9 | VSS | Ground potential | - |
| 10 | XCK | Data input clock signal | “H” → “L” |
| 11 | DL0 | Display data signal | H(ON), L(OFF) |
| 12 | Vcon | Contrast adjust voltage | - |
| 13 | DL1 | Display data signal | H(ON), L(OFF) |
| 14 | VDD | Power supply for logic and LCD | - |
| 15 | VSS | Ground potential | - |
| 16 | VDD | Power supply for logic and LCD | - |
| 17 | DL2 | Display data signal | H(ON), L(OFF) |
| 18 | DISP | Display control signal | H(ON), L(OFF) |
| 19 | DL3 | Display data signal | H(ON), L(OFF) |
| 20 | NC | - | - |
| 21 | VSS | Ground potential | - |
| 22 | DU3 | Display data signal | H(ON), L(OFF) |
| 23 | DU4 | Display data signal | H(ON), L(OFF) |
| 24 | DU2 | Display data signal | H(ON), L(OFF) |
| 25 | DU5 | Display data signal | H(ON), L(OFF) |
| 26 | DU1 | Display data signal | H(ON), L(OFF) |
| 27 | VSS | Ground potential | - |
| 28 | DU0 | Display data signal | H(ON), L(OFF) |
| 29 | DU6 | Display data signal | H(ON), L(OFF) |
| 30 | VSS | Ground potential | - |
| 31 | DU7 | Display data signal | H(ON), L(OFF) |

● CCFT

| Pin No | Symbol | Description | Level |
|--------|--------|-----------------------------------|-------|
| 1 | HV | High voltage line (from Inverter) | - |
| 2 | NC | NC | - |
| 3 | GND | Ground line (from Inverter) | - |

● LCD

Used connector : DF9B-31P-1V(HIROSE)

Mating connector : DF9B-31S-1V(HIROSE)

● CCFT

Used connector : BHR-03VS-1(JST)

Mating connector : SM02(8.0)B-BHS(JST)

Except above connector shall be out of guaranty.

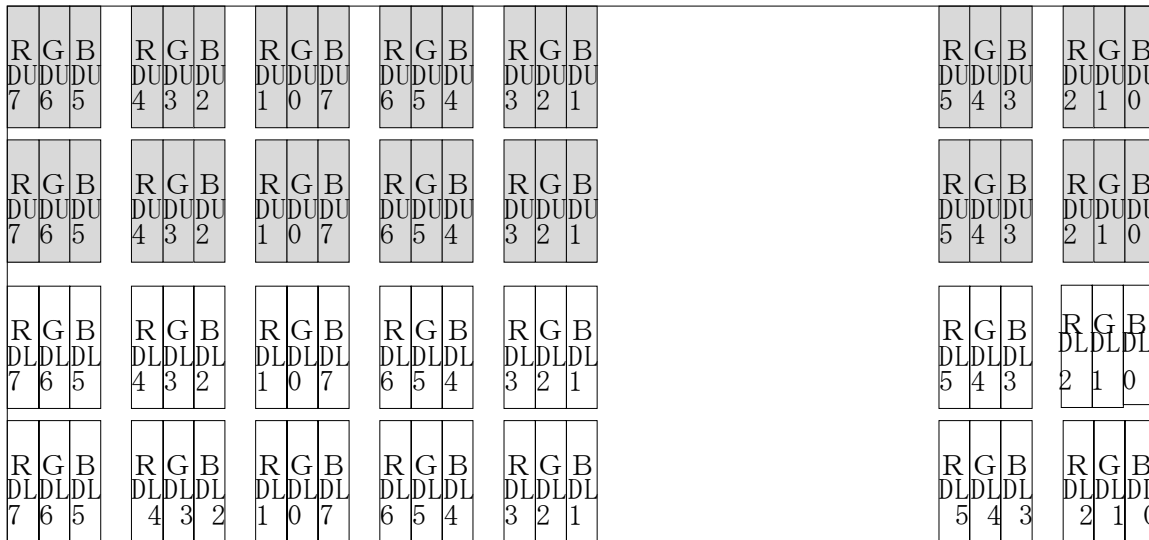
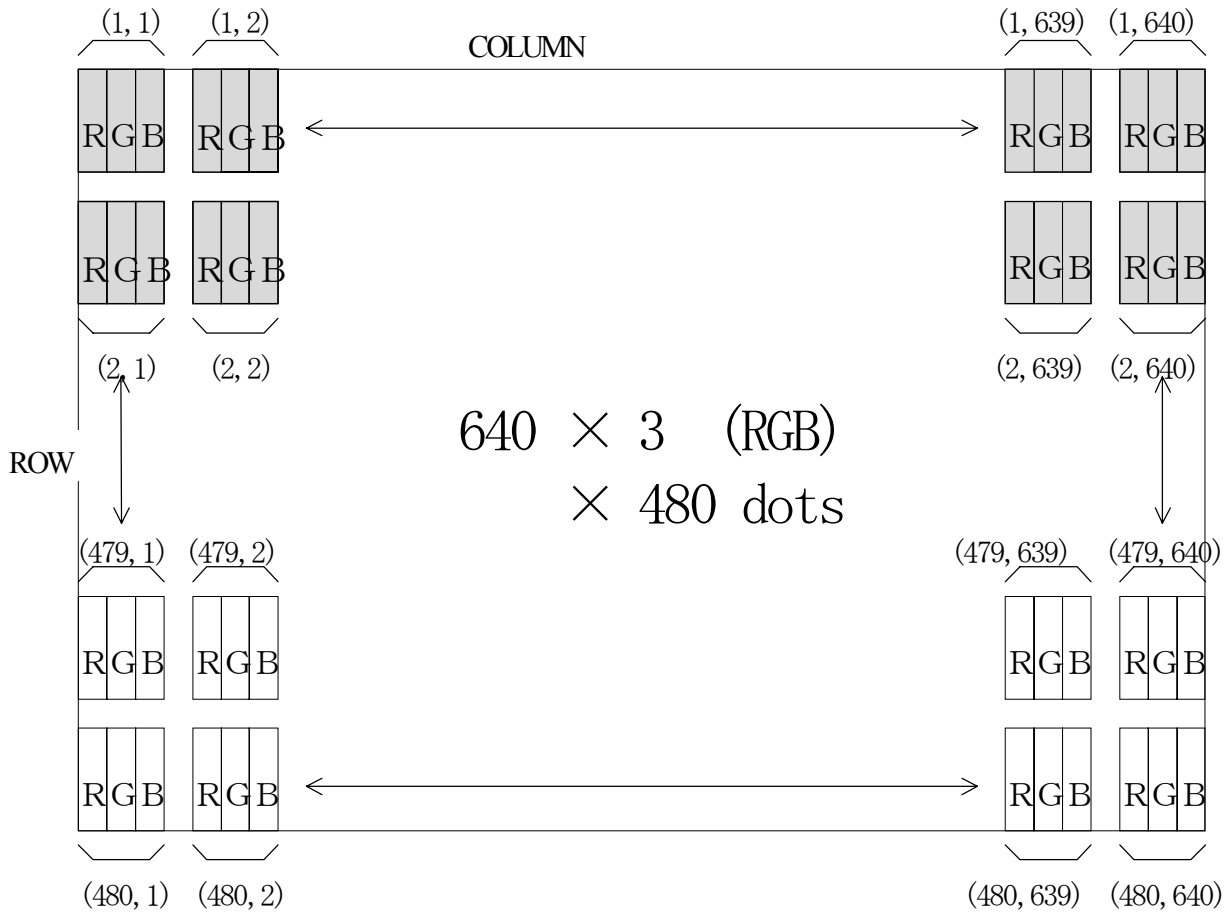

- Upper SEG Drivers , Upper data(DU0-7)
- Lower SEG Drivers , Lower data(DL0-7)

Fig.1 Dot chart of display area

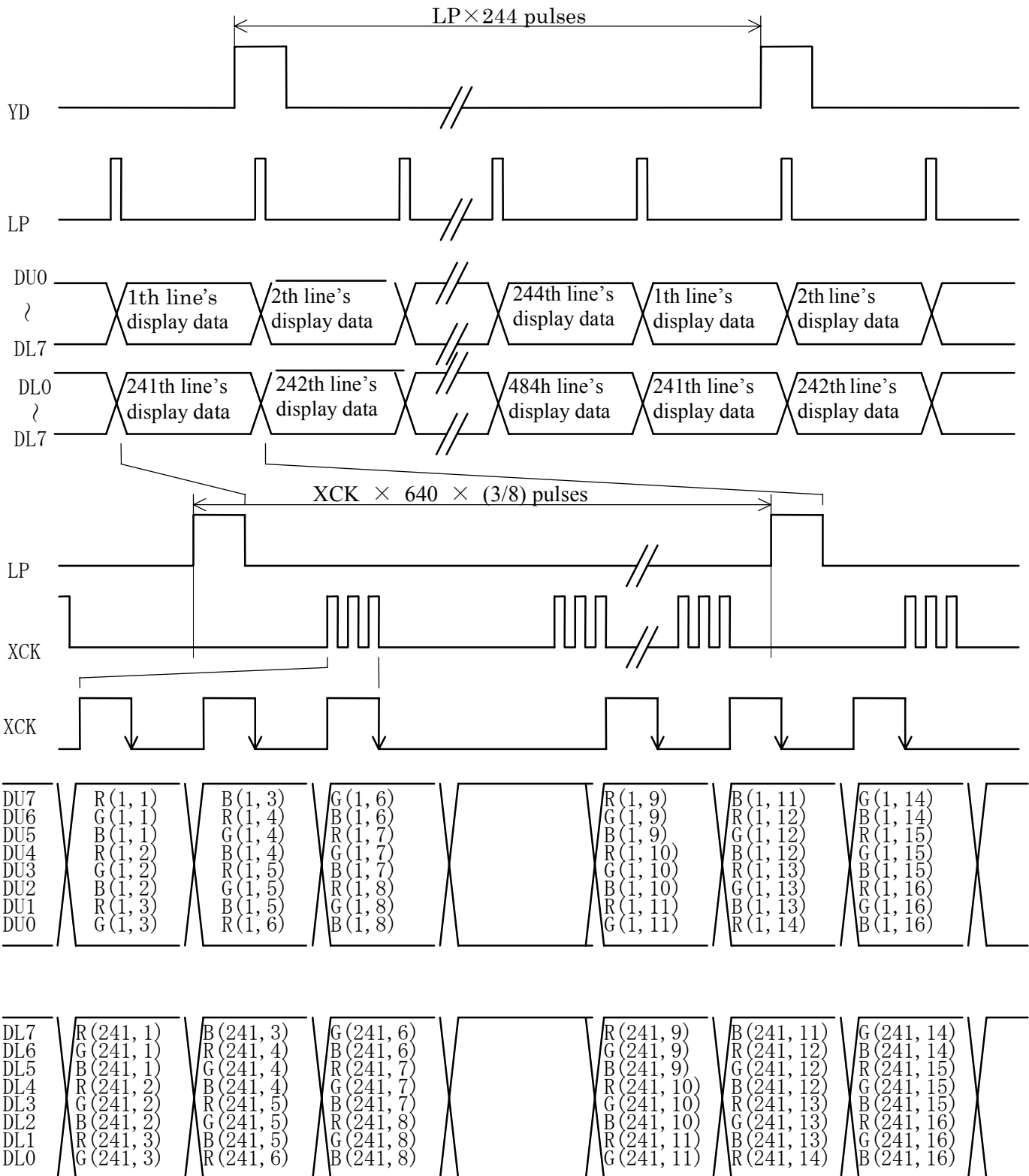

Fig.2 Data Input timing chart

Table 7 Interface timing ratings

| Item | Symbol | Rating | | | Unit |
|--|------------|----------------------------|------|-------|------|
| | | MIN. | TYP. | MAX. | |
| Frame cycle *1 | t_{FRM} | 8.33 | | 16.94 | ms |
| YD signal “H” level set up time | t_{HYS} | 100 | | | ns |
| “H” level hold time | t_{HYH} | 100 | | | ns |
| “L” level set up time | t_{LYS} | 100 | | | ns |
| “L” level hold time | t_{LYH} | 40 | | | ns |
| LP signal “H” level pulse width | t_{WLPH} | 200 | | | ns |
| XCK signal clock cycle | t_{CK} | 80 | | | ns |
| “H” level clock width | t_{WCKH} | 30 | | | ns |
| “L” level clock width | t_{WCKL} | 30 | | | ns |
| Data set up time | t_{DS} | $\frac{\Delta 1}{5}$ 15 | | | ns |
| hold time | t_{DH} | 40 | | | ns |
| LP \uparrow allowance time from XCK \downarrow | t_{LS} | 200 | | | ns |
| XCK \uparrow allowance time from LP \downarrow | t_{LH} | 200 | | | ns |
| Input signal rise/fall time *1 | t_r, t_f | | | 12 | ns |

*1 LCD module functions at the minimum frame cycle of 8.33 ms(Maximum frame frequency of 120 Hz).

Owing to the characteristics of LCD module, “shadowing” will become more eminent as frame frequency goes up, while flicker will be reduced.

According to our experiments, frame cycle of 8.33 ms Min. or frame frequency of 120 Hz Max. will demonstrate optimum display quality in terms of flicker and “shadowing”. But since judgment of display quality is subjective and display quality such as “shadowing” is pattern dependent, it is recommended that decision of frame frequency, to which power consumption of the LCD module is proportional, be made based on your own through testing on the LCD module with every possible patterns displayed on it.

The intervals of one LP fall and next must be always the same, and LPs must be input continuously.

The intervals must be 70 μ s Max.

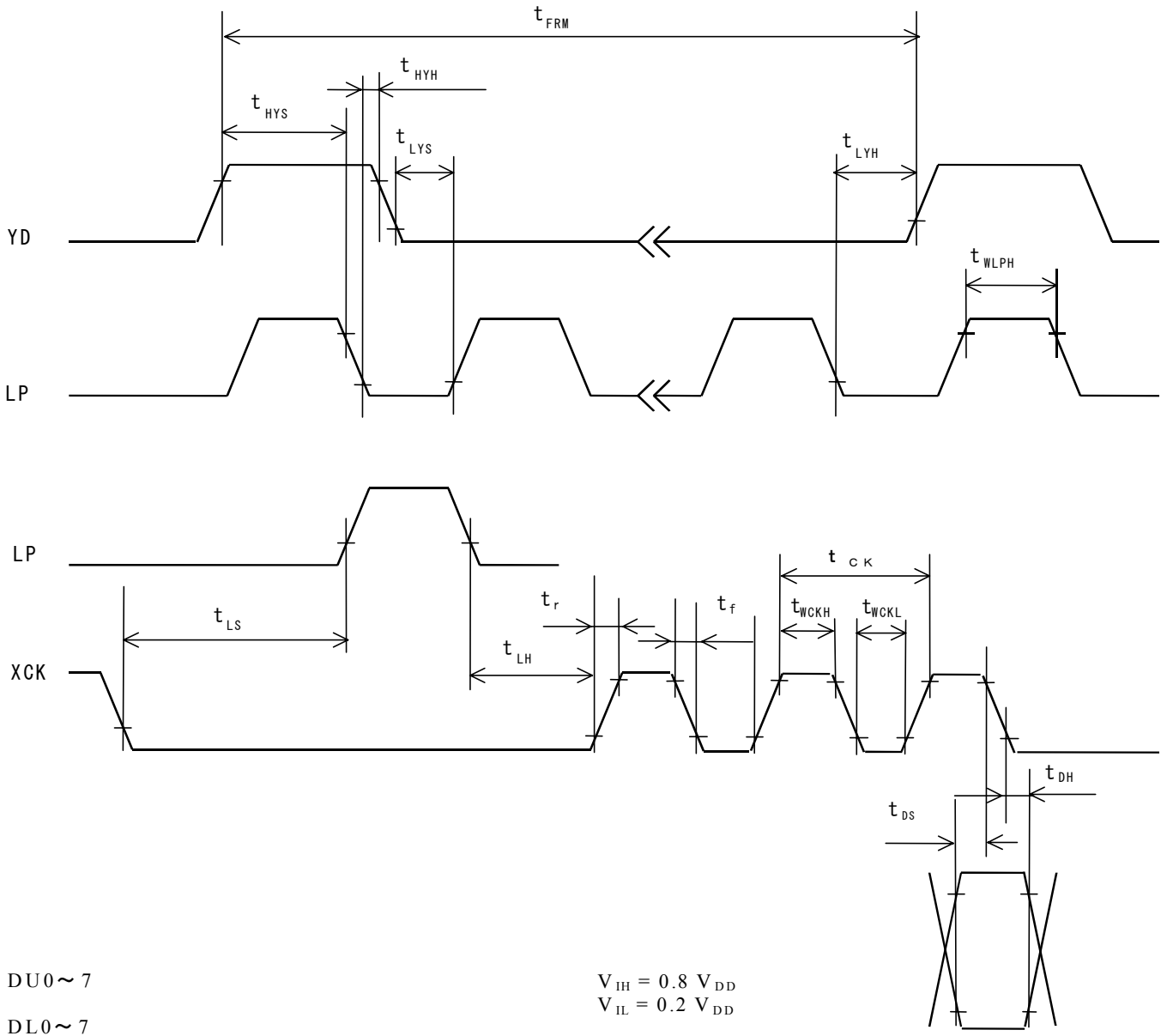

Fig.3 Interface timing chart

6. Module Driving Method

6-1. Circuit configuration

Fig.9 shows the block diagram of the module's circuitry.

6-2. Display face configuration

The display consists of $640 \times 3(R,G,B) \times 480$ dots as shown in Fig. 1.

The interface is single panel with double drive to be driven at 1/240(1/244) duty ratio.

(1/240:an odd number frame, 1/244:an even number frame)

6-3. Input data and control signal

The LCD driver is 240 bits LSI, consisting of shift registers, latch circuits and LCD driver circuits. Input data for each row ($640 \times 3 R,G,B$) will be sequentially transferred in the form of 8 bit parallel data through shift registers from top left of the display together with clock signal (XCK).

When input of one row ($640 \times 3 R,G,B$) is completed, the data will be latched in the form of parallel data corresponding to the signal electrodes by the falling edge of latch signal (LP) then, the corresponding drive signals will be transmitted to the 640×3 lines of column electrodes of the LCD panel by the LCD drive circuits.

At this time, scan start-up signal (YD) has been transferred from the scan signal driver to the 1st row of scan electrodes, and the contents of the data signals are displayed on the 1st row of the display face according to the combinations of voltages applied to the scan and signal electrodes of the LCD. While the data of 1st row are being displayed, the data of 2nd row are entered. When data for 640×3 dots have been transferred, they will be latched by the falling edge of LP, switching the display to the 2nd row.

Such data input will be repeated up to the 240(244)th row of each display segment, from upper row to lower rows, to complete one frame of display by time sharing method.

Simultaneously the same scanning sequence occur at the lower panel.

Then data input proceeds to the next display frame.

YD generates scan signal to drive horizontal electrodes.

Since DC voltage, if applied to LCD panel, causes chemical reaction in LC materials, causing deterioration of the materials, drive wave-form shall be inverted at every display frame to prevent the generation of such DC voltage. Control signal M plays such a role.

Because of the characteristics of CMOS driver LSI, the power consumption of the display module goes up with the clock frequency of XCK.

To minimize data transfer speed of XCK clock the LSI has the system of transferring 8 bit parallel data through the 8 lines of shift registers.

Thanks to this system the power consumption of the display module is minimized.

In this circuit configuration, 8 bit display data shall input to data input pins of DU0-7 and DL0-7.

Furthermore, the display module has bus line system for data input to minimize the power consumption with data input terminals of each driver LSI being activated only when relevant data input is fed.

Data input for column electrodes and chip select of driver LSI are made as follows:

The driver LSI at the left end of the display face is first selected, and the adjacent driver LSI right next side is selected when data of 240 dot (30XCK) is fed. This process is sequentially continued until data is fed to the driver LSI at the right end of the display face. This process is followed simultaneously both at the top and bottom column drivers LSI's.

Thus data input will be made through 8 bit bus line sequentially from the left end of the display face.

Since this display module contains no refresh RAM, it requires the above data and timing pulse inputs even for static display.

The timing chart of input signals are shown in fig. 3 and Table 7.

7. Optical Characteristics

Following spec are based upon the electrical measuring conditions, on which the contrast of perpendicular direction ($\theta_x = \theta_y = 0^\circ$) will be MAX..

Ta=25°C, VDD=5.0V, VCON-VSS=Vmax

Table 8

| Parameter | Symbol | Condition | MIN. | TYP. | MAX. | Unit | Remark | |
|---------------------|------------|---------------------------------|---------------------------------|------|-------|------|--------|---------|
| Viewing angle range | θ_x | Co>5.0 | $\theta_y = 0^\circ$ | -30 | — | 30 | deg. | Note 1) |
| | θ_y | | $\theta_x = 0^\circ$ | -15 | — | 25 | deg. | |
| Contrast ratio | Co | $\theta_x = \theta_y = 0^\circ$ | 35 | 50 | — | — | Note2) | |
| Response time | Rise | τ_r | $\theta_x = \theta_y = 0^\circ$ | — | 220 | 300 | ms | Note3) |
| | Decay | τ_d | $\theta_x = \theta_y = 0^\circ$ | — | 80 | 100 | ms | |
| | | x | $\theta_x = \theta_y = 0^\circ$ | — | 0.275 | — | — | |

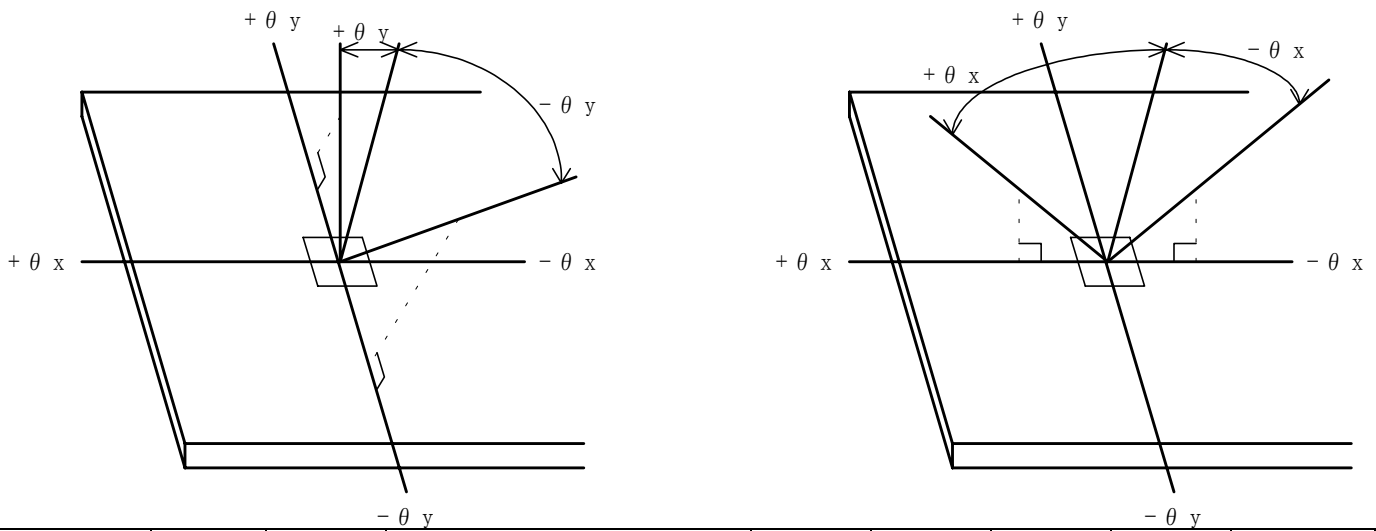

| | | | | | | | | |
|--|--|---|---------------------------------|---|-------|---|---|--|
| | | y | $\theta_x = \theta_y = 0^\circ$ | — | 0.320 | — | — | |
|--|--|---|---------------------------------|---|-------|---|---|--|

Fig.4 Definition of Viewing Angle

Note 1) The viewing angle range is defined as shown Fig.4.

Note 2) Contrast ratio is defined as follows:

$$Co = \frac{\text{Luminance(brightness) all pixes "White" at Vmax}}{\text{Luminance(brightness) all pixes "dark" at Vmax}}$$

Vmax is defined in Fig.6.

Note 3) The response characteristics of photo-detector output are measured as shown in Fig.7, assuming that input signals are applied so as to select and deselect the dot to be measured, in the optical characteristics test method shown in Fig.5.

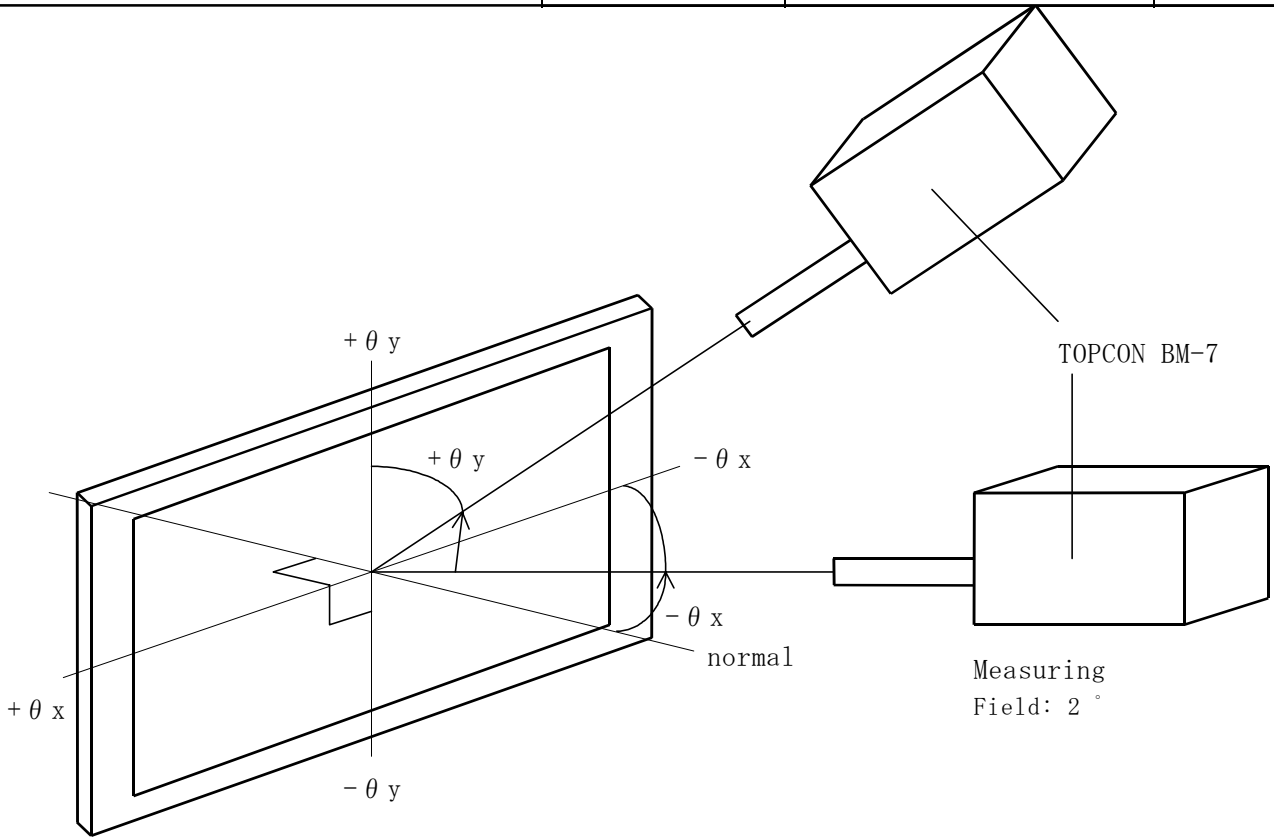

Measuring Spot Size : ϕ 10 mm

θx : Angle from “normal” to viewing surface rotated about the horizontal axis.

θy : Angle from “normal” to viewing surface rotated about the vertical axis.

Fig.5 Optical Characteristics Test Method I

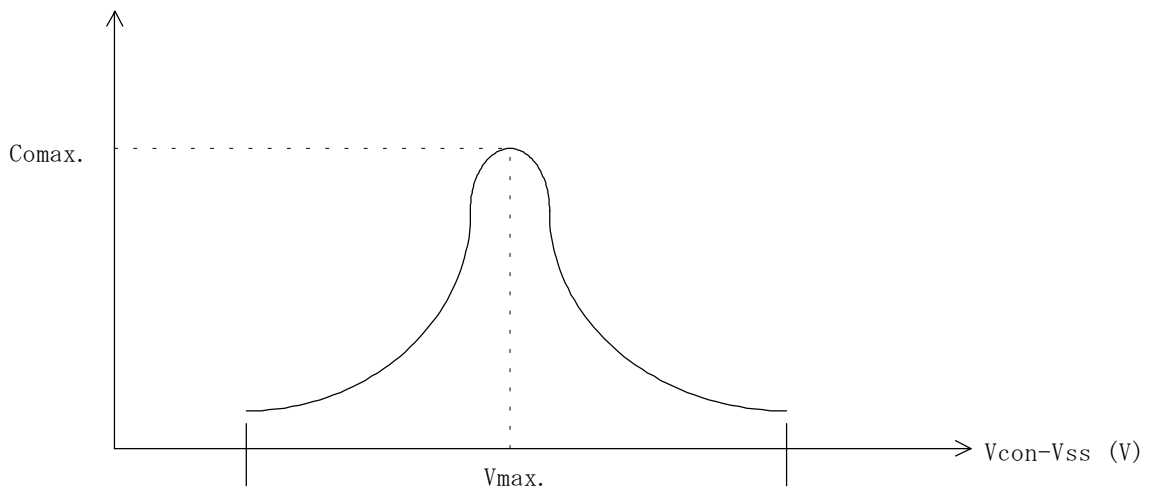
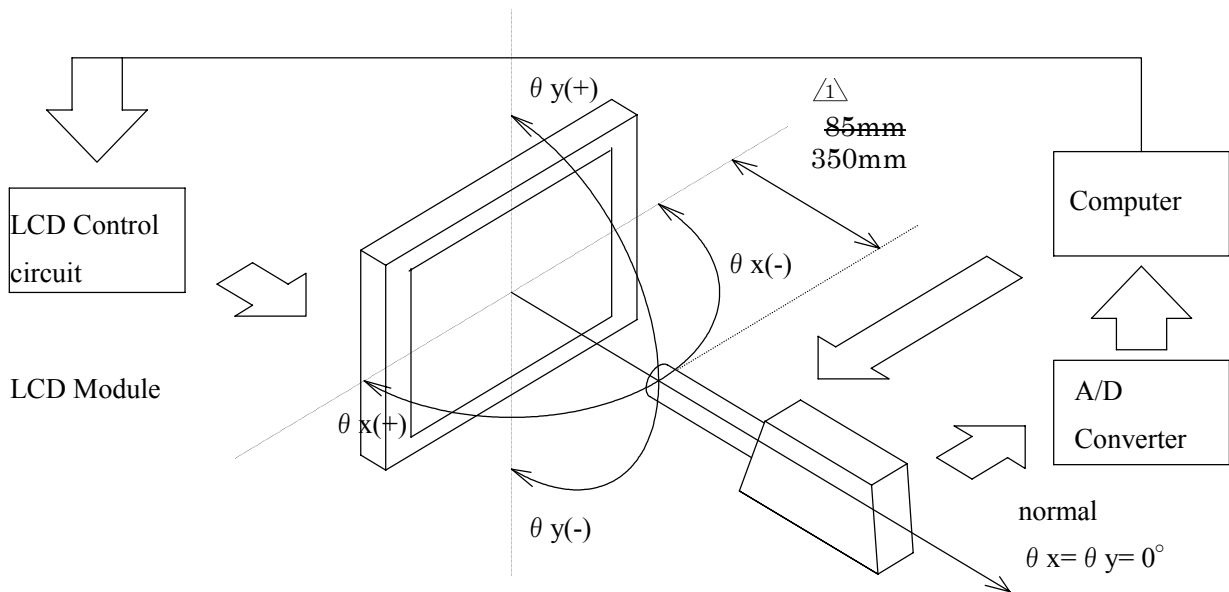

Fig.6 Definition of Vmax

(Response Measurement)

Ta = 25 °C

In dark room



TOPCON BM7 + quartz fiber
(Measuring spot size : ϕ 10 mm, Measuring Field : 2°)

Fig. 7 Optical Characteristics Test Method II

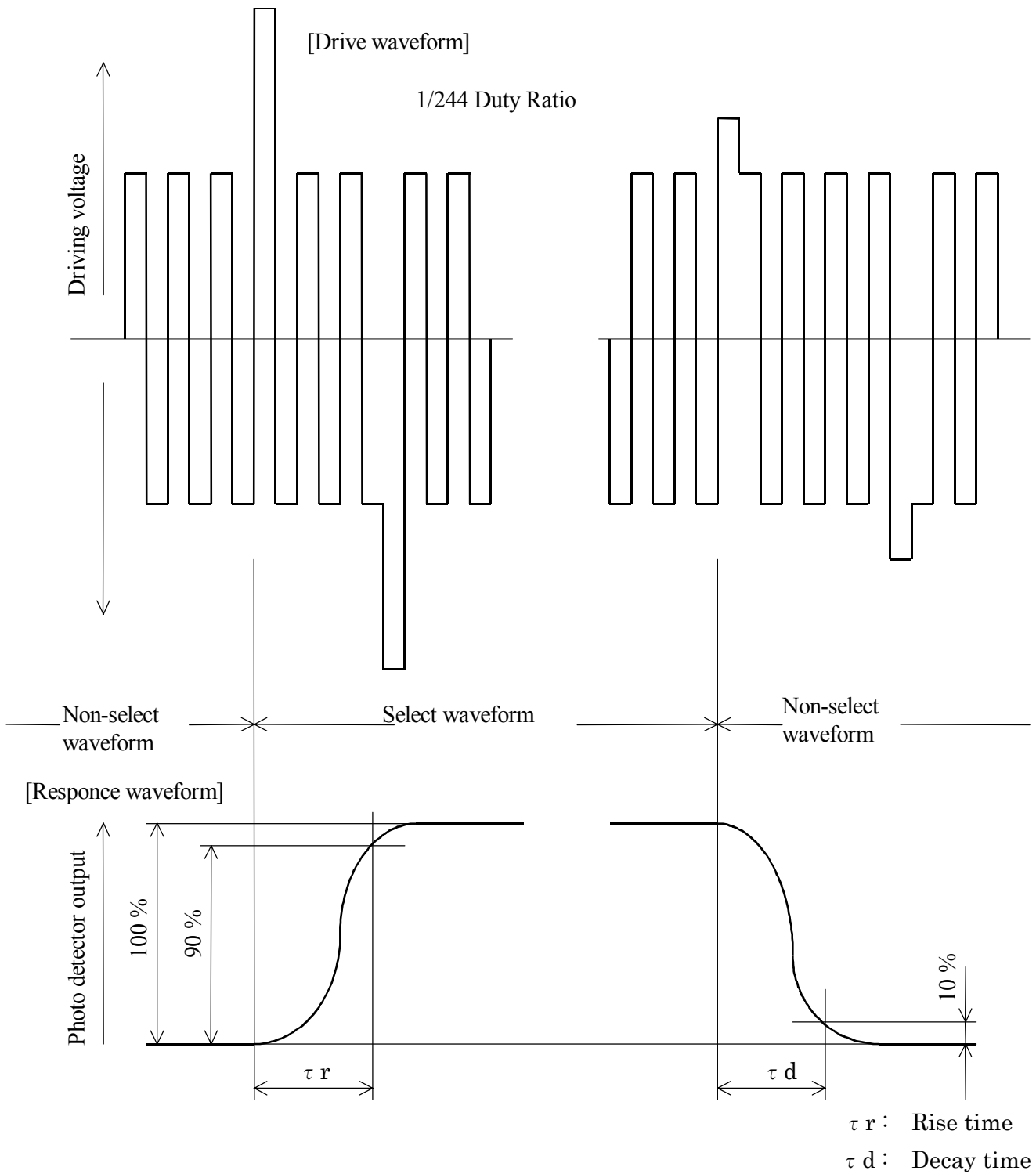

Fig.8 Definition of Response time

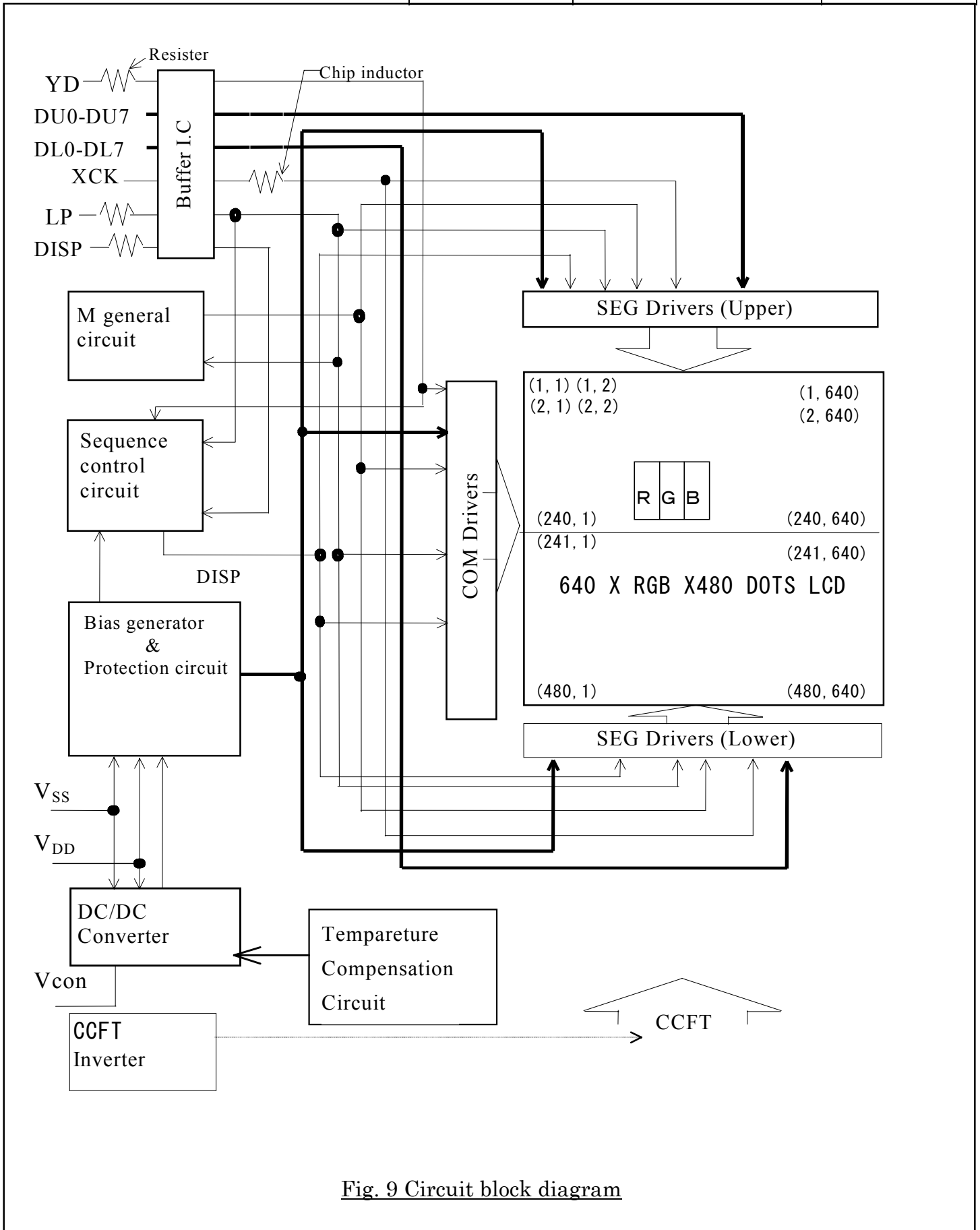

Fig. 9 Circuit block diagram

8.Characteristics of Backlight

The ratings are given on condition that the following conditions are satisfied.

1) Rating(Note)

| Parameter | MIN. | TYP. | MAX. | Unit |
|------------|------|------|------|-------------------|
| Brightness | 120 | 160 | — | cd/m ² |

2) Measurement circuit : CXA-M10L(TDK) (at IL = 5.5 mArms)

3) Measurement equipment : BM-7 (TOPCON Corporation)

4) Measurement conditions

4-1. Measurement circuit voltage : DC = 10.6 V, at primary side

4-2. LCD: All digits WHITE, VDD= 5 V, Vcon-VSS = Vmax,
DU0-7="H"(White), DL0-7="H"(White)

4-3. Ambient temperature : 25 °C

Measurement shall be executed 30 minutes after turning on.

5) Used lamp : K-CE235-24-50BH(WEST ELECTRIC CO.,LTD.) : 1 pc

5-1) Rating (1pc)

| Parameter | Symbol | MIN. | TYP. | MAX. | Unit | Remark |
|------------------------|----------------|--------|--------|------|-------|--------------|
| Lamp voltage | V _L | — | 520 | — | Vrms | — |
| Lamp current | I _L | — | 5.5 | — | mArms | (*1) |
| Lamp power consumption | P _L | — | 2.86 | — | W | (*2) |
| Lamp frequency | F _L | 30 | — | 70 | kHz | — |
| Kick-off voltage | V _S | — | — | 760 | Vrms | Ta=25 °C |
| | | — | — | 1300 | Vrms | Ta= 0 °C(*3) |
| Lamp life time | L _L | 25 000 | 40 000 | — | h | Ta=25 °C(*4) |
| | L _L | 1 000 | — | — | h | Ta=0 °C(*4) |

Within no conductor closed. (CCFT only)

*1 It is recommended that IL be not more than 5.5mArms so that heat radiation of CCFT backlight may least affect the display quality.

*2 Power consumption excluded inverter loss.

*3 The circuit voltage(Vs) of the inverter should be designed to have some margin, because VS may be increased due to the leak current in case of the LCD module.

*4 Average life time of CCFT will be decreased when LCD is operating at lower temperature.

5-2) Operating life

The operating life time is 25 000 hours or more at 5.5 mA , at 25°C.

(Operating life with CXA-M10L or equivalent.)

The inverter should meet the following conditions to keep the specified life time of used lamp;

Since, symmetric waveform without spike in positive and negative

Output frequency range : 30 kHz-70 kHz

Make sure the operating conditions by executing the burn-in enough time.

The operating life time is defined as having ended when any of the following conditions occur;

25± 1 °C

When the voltage required for initial discharge has reached 110 % of the initials value.

When the illuminance quantity of light has decreased to 50 % of the initials value.

(NOTE) Rating are defined as the average brightness inside the viewing area specified in Fig.10.

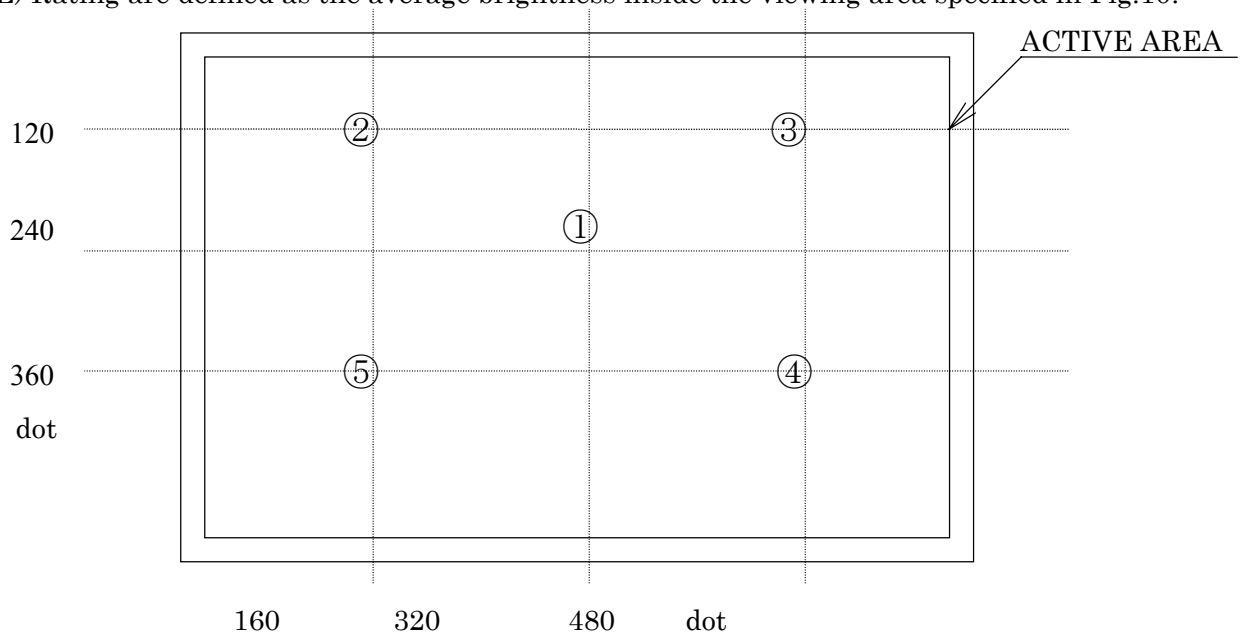

Fig.10 Measuring points (①-⑤)

9. Supply voltage sequence condition

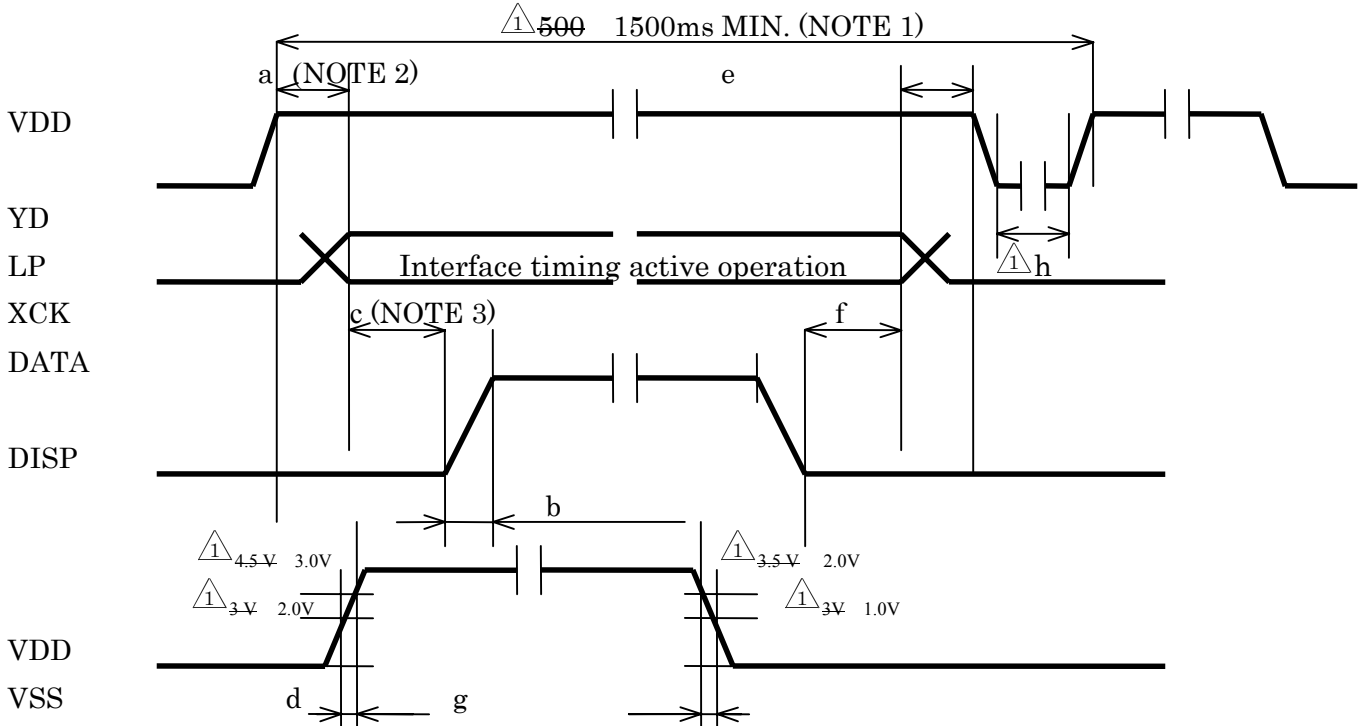

Fig.11 Supply voltage sequence condition

| POWER ON | |
|----------|--------------------|
| Symbol | Allowable value |
| a | 0 ms MIN. 1 s MAX. |
| b | — 100 ns MAX. |
| c | 50 ms MIN. - |
| d | - 10 ms MAX. |

| POWER OFF | |
|------------|---------------------------------|
| Symbol | Allowable value |
| e | 0 ms MIN. 1 s MAX. |
| f | 0 ms MIN. 1 s MAX. |
| g | Δ 10 ms MIN. 1 ms MIN. — |
| Δ h | 1s MIN. — |

(NOTE 1) Power ON/OFF cycle time. All signals and power line shall be in accordance with above sequence in case of power ON/OFF.

(NOTE 2) In this period, YD and LP shall be “L” level.

(NOTE 3) Before DISP rise up, the signals of YD,LP,XCK,DATA must be input, and the above condition of “a” must be satisfied. The signals which comply with the interface timing in Fig.2, Fig.3, and table 7, must be input.

10. Cautions

- 1) Industrial(Mechanical) design of the product in which this LCD module will be incorporated must be made so that the viewing angle characteristics of the LCD may be optimized.

This module's viewing angle is illustrated in Fig.12.

$\theta y \text{ MIN.} < \text{viewing angle} < \theta y \text{ MAX.}$

(For the specific values of $\theta y \text{ MIN.}$, and $\theta y \text{ MAX.}$, refer to the table8)

Please consider the optimum viewing conditions according to the purpose when installing the module.

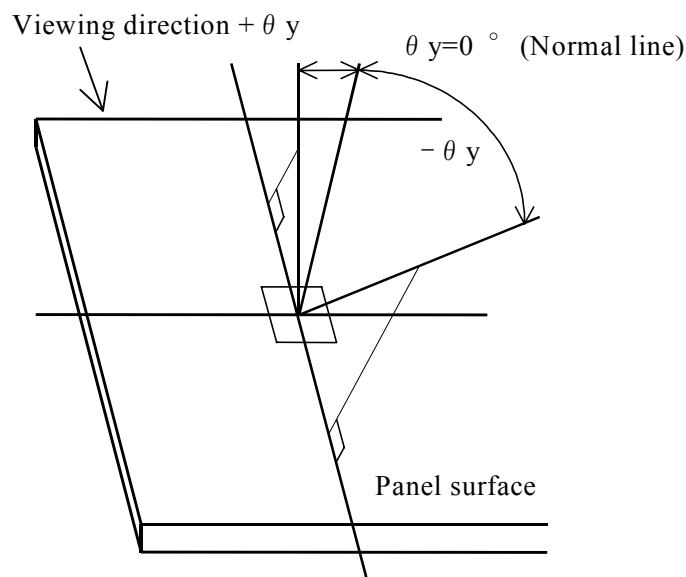

Fig.12 Definition of viewing angle

- 2) This module should be installed using mounting holes of metal bezel. When installing the module, pay attention and handle carefully not to allow any undue stress such as twist or bend.
- 3) Since the front polarizer is easily damaged. Please pay attention not to scratch on its face.
It is recommended to use a transparent acrylic resin board or other type of protective panel on the surface of the LCD module to protect the polarizer, LCD panel, etc..
- 4) If the surface of the LCD panel is required to be cleaned, wipe it swiftly with cotton or other soft cloth. If it is not still clear completely, blow on and wipe it.
- 5) Water droplets, etc. must be wiped off immediately since they may cause color changes, staining, etc., if it remained for a long time.
- 6) Since LCD is made of glass substrate, dropping the module or banging it against hard objects may cause cracking or fragmentation.
- 7) Since CMOS LSIs are equipped in this module, following countermeasures must be taken to avoid electrostatics charge.

1. Operator

Electrostatic shielding clothes shall be had because it is feared that the static electricity is electrified to human body in case that operator have a insulating garment.

2. Equipment

There is a possibility that the static electricity is charged to equipment which have a function of peeling or mechanism of friction(EX: Conveyer, soldering iron, working table), so the countermeasure (electrostatic earth: $1 \times 10^8 \Omega$) should be made.

3. Floor

Floor is a important part to leak static electricity which is generated from human body or equipment. There is a possibility that the static electricity is charged to them without leakage in case of insulating floor, so the countermeasure (electrostatic earth: $1 \times 10^8 \Omega$) should be made.

4. Humidity

Humidity of working room may lower electrostatics generating material's resistance and have something to prevent electrifying. So, humidity should be kept over 50% because humidity less than 50 % may

increase material's electrostatic earth resistance and it become easy to electrify.

5. Transportation/storage

The measure should be made for storage materials because there is a possibility that the static electricity, which electrify to human body or storage materials like container by friction or peeling, cause the dielectric charge.

6. Others

The laminator is attached on the surface of LCD module to prevent from scratches, fouling and dust. It should be peeled off unhurriedly with using static eliminator.

And also, static eliminator should be installed to prevent LCD module from electrifying at assembling line.

- 8) Don't use any materials which emit gas from epoxy resin(amines' hardener) and silicon adhesive agent(dealcohol or deoxym) to prevent change polarizer color owing to gas.
- 9) Since leakage current, which may be caused by routing of CCFT cables, etc., may affect the brightness of display, the inverter has to be designed taking the leakage current into consideration. Thorough evaluation of the LCD module/inverter built into its host equipment shall be conducted, therefore, to ensure the specified brightness.
- 10) Avoid to expose the module to the direct sun-light, strong ultraviolet light, etc. for a long time.
- 11) If stored at temperatures under specified storage temperature, the LC may freeze and be deteriorated. If storage temperature exceed the specified rating, the molecular orientation of the LC may change to that of a liquid, and they may not revert to their original state. Therefore, the module should be always stored at normal room temperature.
- 12) Disassembling the LCD module can cause permanent damage and should be strictly avoided.

13) Procedure insert mating connector

When the mating connector is inserted, it should be parallel to the used connector of LCD module and it should be inserted on horizontal firm base.

When the mating connector is attempted to be fixed to LCD connector, it should be inserted properly in order not to create a gap as shown following diagram 2).

Please insert the connector as both edge is placed to the connect position of LCD connector.

1) Method of correct insert

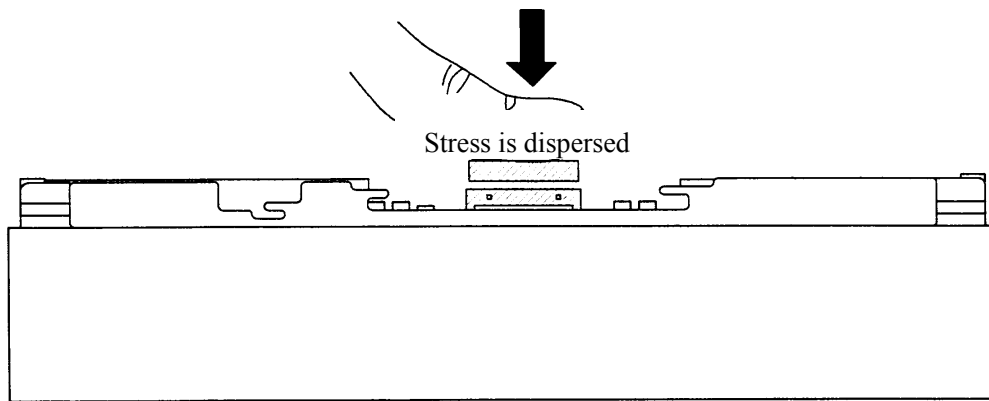

Base (horizontal film base) is required

2) Method of wrong insert

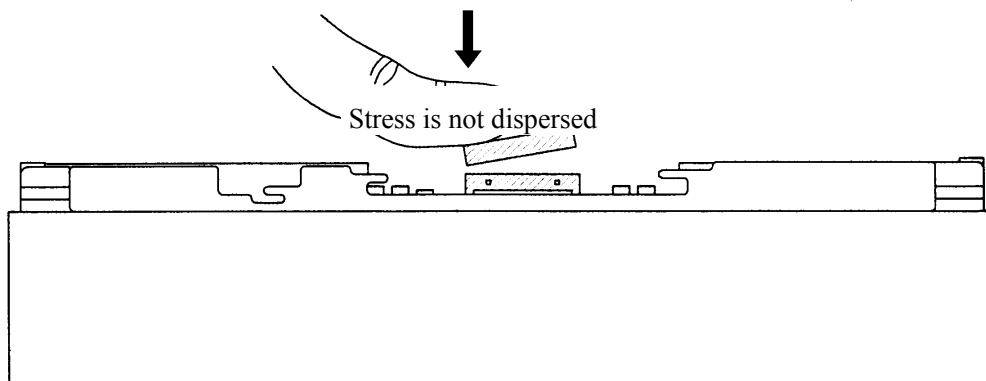

Base (horizontal film base) is required

- 14) This specification describes display quality in case of no gray scale. Since display quality can be affected by gray scale methods, display quality shall be carefully evaluated for the usability of LCD module in case gray scale is displayed on the LCD module.
- 15) The module should be driven according to the specified ratings to avoid permanent damage. DC voltage drive leads to rapid deterioration of LC, so ensure that the drive is alternating waveform by continuous application of the signal M. Especially the power ON/OFF sequence shown on Page 21 should be kept to avoid latch-up of drive LSI and application of DC voltage to LCD panel
- 16) It is a characteristic of LCD to maintain the displaying pattern when the pattern is applied for a long time.(Image retention)
To prevent image retention, please do not apply the fixed pattern for along time by pre-installing such programs at your side.
- 17) This phenomenon (image retention) is not deterioration of LCD. If it happens, you can remove it by applying different patterns.
- 18) CCFT backlight should be kept OFF during VDD is "L" level.

11. Applicable inspection standard

The LCD module shall meet the following inspection standard : \triangle S-U-014 S-U-035

WARNING

Don't use any materials which emit following gas from epoxy resin (amines' hardener) and silicone adhesive agent (dealcohol or deoxym) to prevent change polarizer color owing to gas.

| | |
|---------------------------------|---------------------|
| 出図 ISSUE | |
| 設計変更 DRAWING INFO No. () | 変更情報 INFORMATION |
| 新製 NEW | 変更 CHANGE |
| 交換 COMPL | 置換 REPLACE |

Fig.13 LCD Module outline dimensions

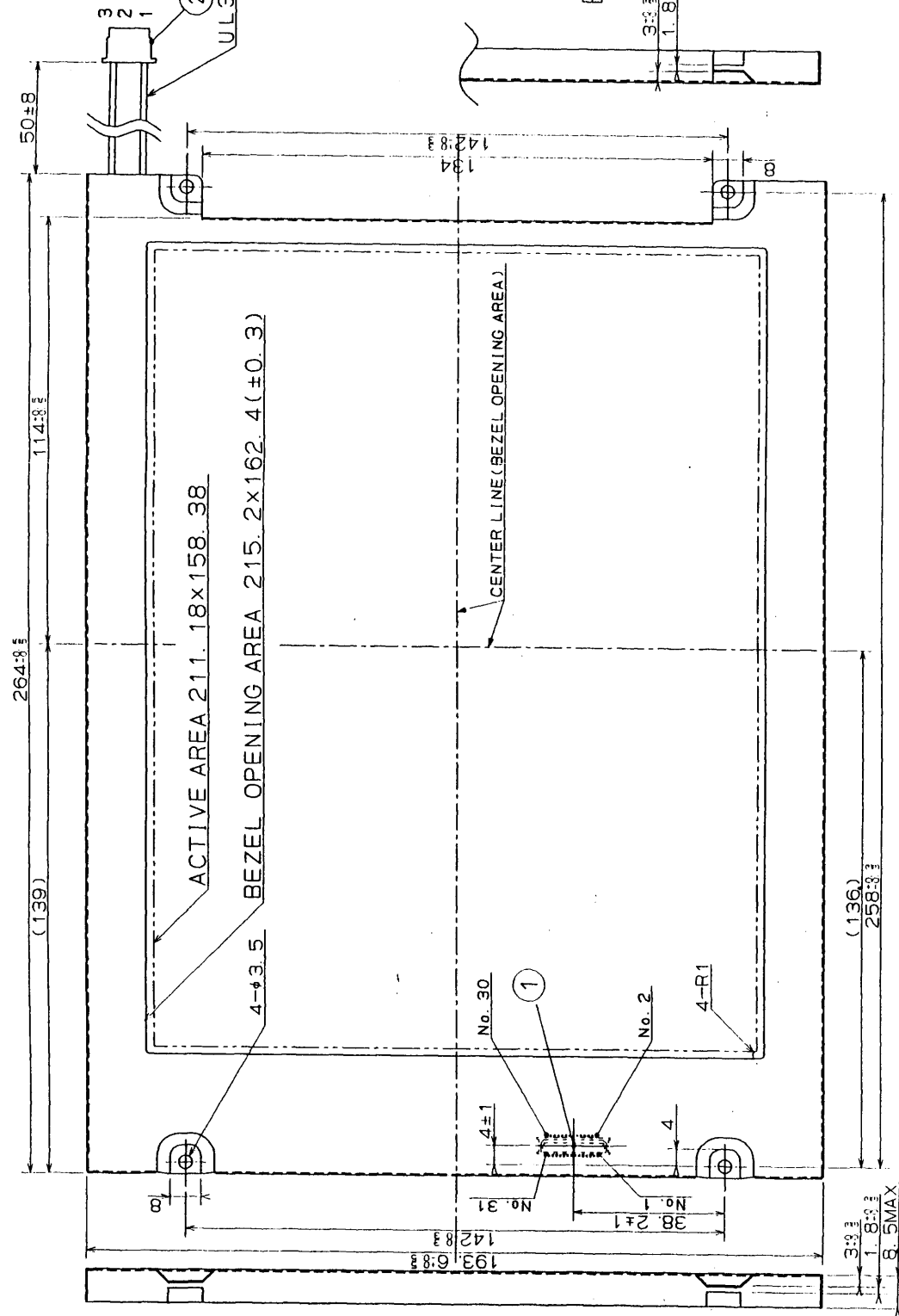

② CCFT CONNECTOR
BHR-03VS-1(JST)
◁PIN LAYOUT▶

| | | | |
|-----|---|----|------|
| PIN | 1 | 2 | 3 |
| | V | NC | DATA |

BEZEL/DISPLAY POSITION

- 1) TOLERANCE X-DIRECTION A: 2.0±0.8
- 2) TOLERANCE Y-DIRECTION B: 2.0±0.8
- 3) OBLIQUITY OF DISPLAY AREA IC-DI<0.8

指定公差は三二進法 ±0.5
UNSPECIFIED CC TO BE

| | | | |
|-------------------|----------|-------------------|------------------|
| 品名 NAME | LC99213A | 品名 NAME | LM10V332 |
| 図番 SYMBOL | | 図番 SYMBOL | 640RGBx480 P0.33 |
| 部番 PARTS CODE | | 部番 PARTS CODE | |
| 検査 INSPECTION | | 検査 INSPECTION | 300.2 |
| 製造 MANUFACTURE | | 製造 MANUFACTURE | |
| 設計 DESIGN | | 設計 DESIGN | OD10V3321110 |

Excluded the allowance of deformation
① INTERFACE CONNECTOR
DF98-31P-1V(HIROSE)
◁PIN LAYOUT▶

| | | | | | | | | | | | | | | | |
|-----|-----|-----|-----|-----|-----|-----|-----|-----|-----|-----|-----|-----|-----|-----|-----|
| PIN | 1 | 2 | 3 | 4 | 5 | 6 | 7 | 8 | 9 | 10 | 11 | 12 | 13 | 14 | 15 |
| | DL4 | VSS | DL5 | YD | DL6 | LP | DL7 | VSS | DCX | DL8 | WDM | DL1 | V00 | VSS | |
| | 16 | 17 | 18 | 19 | 20 | 21 | 22 | 23 | 24 | 25 | 26 | 27 | 28 | 29 | 30 |
| | V00 | DL2 | DL3 | DL3 | NC | VSS | DL3 | DL4 | DL2 | DL5 | DL5 | DL1 | VSS | DL0 | DL6 |
| | | | | | | | | | | | | | | | |

SHARP CORPORATION
シャープ株式会社 液晶事業部 (本社)

SPECIFICATIONS ARE SUBJECT TO CHANGE WITHOUT NOTICE.

Suggested applications (if any) are for standard use; See Important Restrictions for limitations on special applications. See Limited Warranty for SHARP's product warranty. The Limited Warranty is in lieu, and exclusive of, all other warranties, express or implied. ALL EXPRESS AND IMPLIED WARRANTIES, INCLUDING THE WARRANTIES OF MERCHANTABILITY, FITNESS FOR USE AND FITNESS FOR A PARTICULAR PURPOSE, ARE SPECIFICALLY EXCLUDED. In no event will SHARP be liable, or in any way responsible, for any incidental or consequential economic or property damage.

SHARP®

NORTH AMERICA

SHARP Microelectronics of the Americas
5700 NW Pacific Rim Blvd.
Camas, WA 98607, U.S.A.
Phone: (1) 360-834-2500
Fax: (1) 360-834-8903
Fast Info: (1) 800-833-9437
www.sharpsma.com

EUROPE

SHARP Microelectronics Europe
Division of Sharp Electronics (Europe) GmbH
Sonninstrasse 3
20097 Hamburg, Germany
Phone: (49) 40-2376-2286
Fax: (49) 40-2376-2232
www.sharpsme.com

JAPAN

SHARP Corporation
Electronic Components & Devices
22-22 Nagaike-cho, Abeno-Ku
Osaka 545-8522, Japan
Phone: (81) 6-6621-1221
Fax: (81) 6117-725300/6117-725301
www.sharp-world.com

TAIWAN

SHARP Electronic Components
(Taiwan) Corporation
8F-A, No. 16, Sec. 4, Nanking E. Rd.
Taipei, Taiwan, Republic of China
Phone: (886) 2-2577-7341
Fax: (886) 2-2577-7326/2-2577-7328

SINGAPORE

SHARP Electronics (Singapore) PTE., Ltd.
438A, Alexandra Road, #05-01/02
Alexandra Technopark,
Singapore 119967
Phone: (65) 271-3566
Fax: (65) 271-3855

KOREA

SHARP Electronic Components
(Korea) Corporation
RM 501 Geosung B/D, 541
Dohwa-dong, Mapo-ku
Seoul 121-701, Korea
Phone: (82) 2-711-5813 ~ 8
Fax: (82) 2-711-5819

CHINA

SHARP Microelectronics of China
(Shanghai) Co., Ltd.
28 Xin Jin Qiao Road King Tower 16F
Pudong Shanghai, 201206 P.R. China
Phone: (86) 21-5854-7710/21-5834-6056
Fax: (86) 21-5854-4340/21-5834-6057

Head Office:

No. 360, Bashen Road,
Xin Development Bldg. 22
Waigaoqiao Free Trade Zone Shanghai
200131 P.R. China
Email: smc@china.global.sharp.co.jp

HONG KONG

SHARP-ROXY (Hong Kong) Ltd.
3rd Business Division,
17/F, Admiralty Centre, Tower 1
18 Harcourt Road, Hong Kong
Phone: (852) 28229311
Fax: (852) 28660779
www.sharp.com.hk

Shenzhen Representative Office:

Room 13B1, Tower C,
Electronics Science & Technology Building
Shen Nan Zhong Road
Shenzhen, P.R. China
Phone: (86) 755-3273731
Fax: (86) 755-3273735