

# Rayson

## Bluetooth® Module

### Class2 BC04-ext Module

### BTM-112

#### Features

- The module is a Max.4dBm( Class2 ) module.
- Bluetooth standard Ver. 2.0 + EDR conformity.
- Internal 1.8V regulator
- Low current consumption :  
**Hold,Sniff,Park,Deep sleep Mode**
- 3.0v to 3.6v operation
- Support for up to seven slaves :  
**SCO links,ACL links,Piconet<7>**
- Interface: USB,UART&PCM(for voice CODEC)
- SPP firmware with AT command sets
- Small outline. 25 x 14.5 x 2.2 mm

#### Applications

- Notebook PC
- PDA
- Digital camera & printer
- GPS,POS, Barcode Reader
- Domestic and industrial applications

#### Outline



#### General Electrical Specification

Parameter	Description	Min.	Typ.	Max.	Units
Carrier Frequency		2.402		2.480	GHz
Operating Voltage (VDD)		3.00	3.30	3.60	V
RF Output Power	Measured in 50 ohm	-6	0	4	dBm
RX Sensitivity			-83	-70	dBm
Load Impedance	No abnormal Oscillation			5:1	-
Input Low Voltage	RESET,UART,GPIO,PCM	-0.30	-	0.80	V
Input High Voltage	RESET,UART,GPIO,PCM	0.70VDD	-	VDD+0.30	V
Output Low Voltage	UART,GPIO,PCM	-	-	0.40	V
Output High Voltage	UART,GPIO,PCM	VDD-0.40	-	-	V
Average Current Consumption	SCO connection HV1		46	-	mA
Peak Current	Tx burst +4dBm		-	80	mA

#### Block Diagram

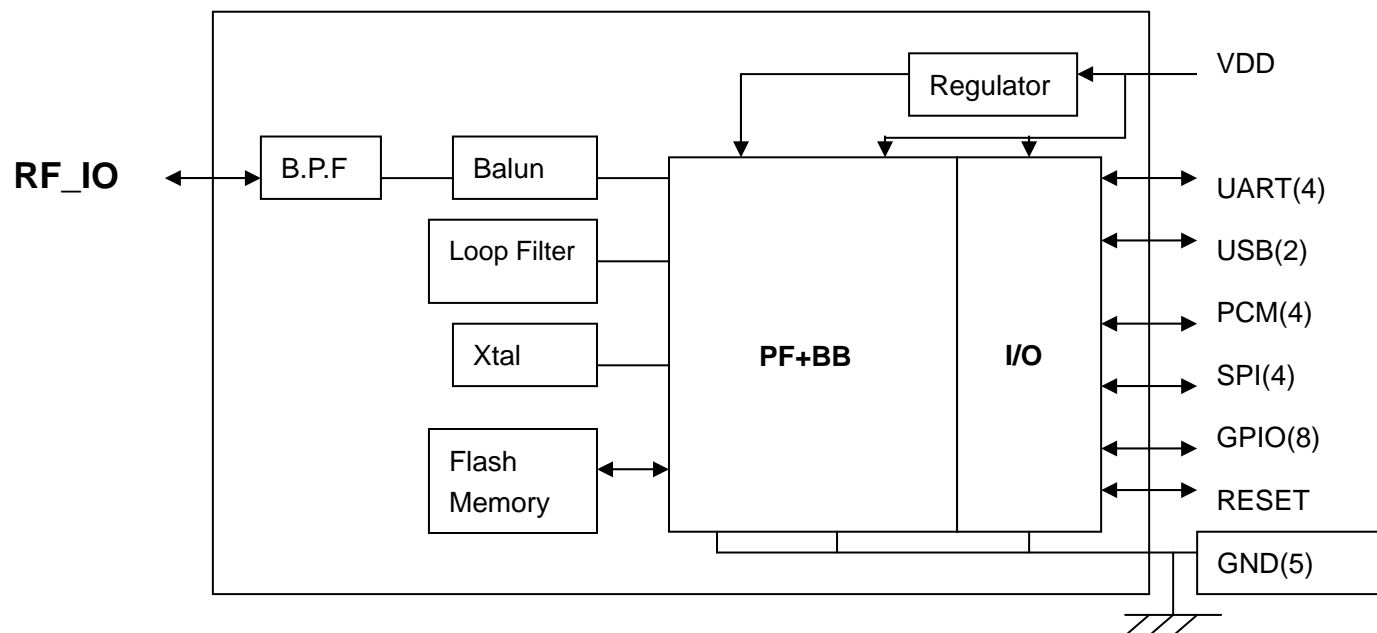

## BTM-11x Specification

### Radio Characteristics – Basic Data Rate

Radio Characteristics, VDD = 3.3V Temperature =+20°C						
	Frequency (GHz)	Min	Typ	Max	Bluetooth Specification	Unit
Sensitivity at 0.1% BER	2.402	-	-83	-82	≤ - 70	dBm
	2.441	-	-83	-82		dBm
	2.480	-	-83	-82		dBm
Maximum received signal at 0.1% BER	2.402	-	-6	0	≥ - 20	dBm
	2.441	-	-6	0		dBm
	2.480	-	-6	0		dBm
RF transmit power <sup>(1)</sup>	2.402	-	+2	-	-6 to +4 <sup>(2)</sup>	dBm
	2.441	-	+2	-		dBm
	2.480	-	+2	-		dBm
Initial carrier frequency tolerance	2.402	-	12	20	±75	kHz
	2.441	-	10	20		kHz
	2.480	-	9	20		kHz
20dBm bandwidth for modulated carrier	2.402	-	879	1000	≤ 1000	kHz
	2.441	-	816	1000		kHz
	2.480	-	819	1000		kHz
Drift (single slot packet)	2.402	-	-	20	≤25	kHz
	2.441	-	-	20		kHz
	2.480	-	-	20		kHz
Drift (five slot packet)	2.402	-	-	20	≤40	kHz
	2.441	-	-	20		kHz
	2.480	-	-	20		kHz
Drift Rate	2.402	-	-	15	20	kHz/50µs
	2.441	-	-	15		kHz/50µs
	2.480	-	-	15		kHz/50µs
RF power control range		16	35	-	≥16	dB
RF power range control resolution		-	1.8	-	-	dB
Δf1 <sup>avg</sup> "Maximum Modulation"	2.402	145	165	175	140<Δf1 <sup>avg</sup> <175	kHz
	2.441	145	165	175		kHz
	2.480	145	165	175		kHz
Δf2 <sup>maz</sup> "Minimum Modulation"	2.402	115	150	-	115	kHz
	2.441	115	150	-		kHz
	2.480	115	150	-		kHz
C/I co-channel		-	10	11	≤ 11	dB
Adjacent channel selectivity C/I F=F <sub>0</sub> +1 MHz <sup>(3)(5)</sup>		-	-4	0	≤ 0	dB
Adjacent channel selectivity C/I F=F <sub>0</sub> - 1MHz <sup>(3)(5)</sup>		-	-4	0	≤ 0	dB
Adjacent channel selectivity C/I F=F <sub>0</sub> +2 MHz <sup>(3)(5)</sup>		-	-35	-30	≤ - 30	dB
Adjacent channel selectivity C/I F=F <sub>0</sub> - 2MHz <sup>(3)(5)</sup>		-	-21	-20	≤ - 20	dB
Adjacent channel selectivity C/I F>=F <sub>0</sub> +3 MHz <sup>(3)(5)</sup>		-	-45	-	≤ - 40	dB
Adjacent channel selectivity C/I F<=F <sub>0</sub> -5 MHz <sup>(3)(5)</sup>		-	-45	-	≤ - 40	dB
Adjacent channel selectivity C/I F=F <sub>image</sub> <sup>(3)(5)</sup>		-	-18	-9	≤ - 9	dB
Adjacent channel transmit power F=F <sub>0</sub> ±2MHz <sup>(4)(5)</sup>		-	-35	-20	≤ - 20	dBc
Adjacent channel transmit power F=F <sub>0</sub> ±3MHz <sup>(4)(5)</sup>		-	-55	-40	≤ - 40	dBc

#### Notes:

- (1) BlueCore-External firmware maintains the transmit power to be within the Bluetooth specification v2.0 limits.
- (2) Class 2 RF transmit power range, Bluetooth specification v2.0
- (3) Up to five exceptions are allowed in v2.0 of the Bluetooth specification

(4) Up to three exceptions are allowed in v2.0 of the Bluetooth specification

(5) Measured at  $F_0 = 2441\text{MHz}$

## Radio Characteristics – Enhanced Data Rate

<b>Transmitter , VDD = 3.3V Temperature =+20°C</b>						
	<b>Frequency (GHz)</b>	<b>Min.</b>	<b>Typ.</b>	<b>Max.</b>	<b>Bluetooth Specification</b>	<b>Unit</b>
Maximum RF transmit power	2.402	-6	0	+2	-6 to +20	dBm
	2.441	-6	0	+2		dBm
	2.480	-6	0	+2		dBm
Relative transmit power		-	-1.5	-	-4 to +1	dB
$\pi/4$ DQPSK Maximum carrier frequency stability $w_0$		-	2	-	$\leq \pm 10$ for all blocks	kHz
$\pi/4$ DQPSK Maximum carrier frequency stability $w_i$		-	6	-	$\leq \pm 75$ for all packets	kHz
$\pi/4$ DQPSK Maximum carrier frequency stability $ w_0 + w_i $		-	8	-	$\leq \pm 75$ for all blocks	kHz
8 DPSK Maximum carrier frequency stability $w_0$		-	2	-	$\leq \pm 10$ for all blocks	kHz
8 DPSK Maximum carrier frequency stability $w_i$		-	6	-	$\leq \pm 75$ for all packets	kHz
8 DPSK Maximum carrier frequency stability $ w_0 + w_i $		-	8	-	$\leq \pm 75$ for all blocks	kHz
$\pi/4$ DQPSK Modulation Accuracy	RMS DVEM	-	7	-	$\leq 20$	%
	99% DEVM	-	13	-	$\leq 30$	%
	Peak DEVM	-	19	-	$\leq 35$	%
8 DPSK Modulation Accuracy	RMS DVEM	-	7	-	$\leq 13$	%
	99% DEVM	-	13	-	$\leq 20$	%
	Peak DEVM	-	17	-	$\leq 25$	%
In-band spurious emissions	$F > F_0 + 3\text{ MHz}$	-	<-50	-	$\leq -40$	dBm
	$F < F_0 - 3\text{ MHz}$	-	<-50	-	$\leq -40$	dBm
	$F = F_0 - 3\text{ MHz}$	-	-46	-	$\leq -40$	dBm
	$F = F_0 - 2\text{ MHz}$	-	-34	-	$\leq -20$	dBm
	$F = F_0 - 1\text{ MHz}$	-	-35	-	$\leq -26$	dBm
	$F = F_0 + 1\text{ MHz}$	-	-35	-	$\leq -26$	dBm
	$F = F_0 + 2\text{ MHz}$	-	-31	-	$\leq -20$	dBm
$F = F_0 + 3\text{ MHz}$	-	-33	-	$\leq -40$	dBm	
EDR Differential Phase Encoding			No Errors		$\geq 99$	%
<b>Receiver , VDD = 3.3V Temperature =+20°C</b>						
	<b>Modulation</b>	<b>Min.</b>	<b>Typ.</b>	<b>Max.</b>	<b>Bluetooth Specification</b>	<b>Unit</b>
Sensitivity at 0.1% BER	$\pi/4$ DQPSK	-	-82	-	$\leq -70$	dBm
	8 DPSK	-	-76	-	$\leq -70$	dBm
Maximum received signal level at 0.1% BER	$\pi/4$ DQPSK	-	-8	-	$\geq -20$	dBm
	8 DPSK	-	-10	-	$\geq -20$	dBm
C/I co-channel at 0.1% BER	$\pi/4$ DQPSK	-	10	-	$\leq +13$	dB
	8 DPSK	-	19	-	$\leq +21$	dB
Adjacent channel selectivity C/I $F = F_0 + 1\text{ MHz}$	$\pi/4$ DQPSK	-	-10	-	$\leq 0$	dB
	8 DPSK	-	-5	-	$\leq +5$	dB
Adjacent channel selectivity C/I $F = F_0 - 1\text{ MHz}$	$\pi/4$ DQPSK	-	-11	-	$\leq 0$	dB
	8 DPSK	-	-5	-	$\leq +5$	dB

Adjacent channel selectivity C/I F=F <sub>0</sub> +2 MHz	$\pi/4$ DQPSK	-	-40	-	$\leq -30$	dB
	8 DPSK	-	-40	-	$\leq -25$	dB
Adjacent channel selectivity C/I F=F <sub>0</sub> -2 MHz	$\pi/4$ DQPSK	-	-23	-	$\leq -20$	dB
	8 DPSK	-	-20	-	$\leq -13$	dB
Adjacent channel selectivity C/I F=F <sub>0</sub> +3 MHz	$\pi/4$ DQPSK	-	-45	-	$\leq -40$	dB
	8 DPSK	-	-45	-	$\leq -33$	dB
Adjacent channel selectivity C/I F=F <sub>0</sub> -5 MHz	$\pi/4$ DQPSK	-	-45	-	$\leq -40$	dB
	8 DPSK	-	-45	-	$\leq -33$	dB
F <sub>0</sub> = 2405, 2441, 2477 MHz						
Adjacent channel selectivity C/I F=F <sub>image</sub>	$\pi/4$ DQPSK		-20		$\leq -7$	dB
	8 DPSK		-15		$\leq 0$	dB

## Application Schematic

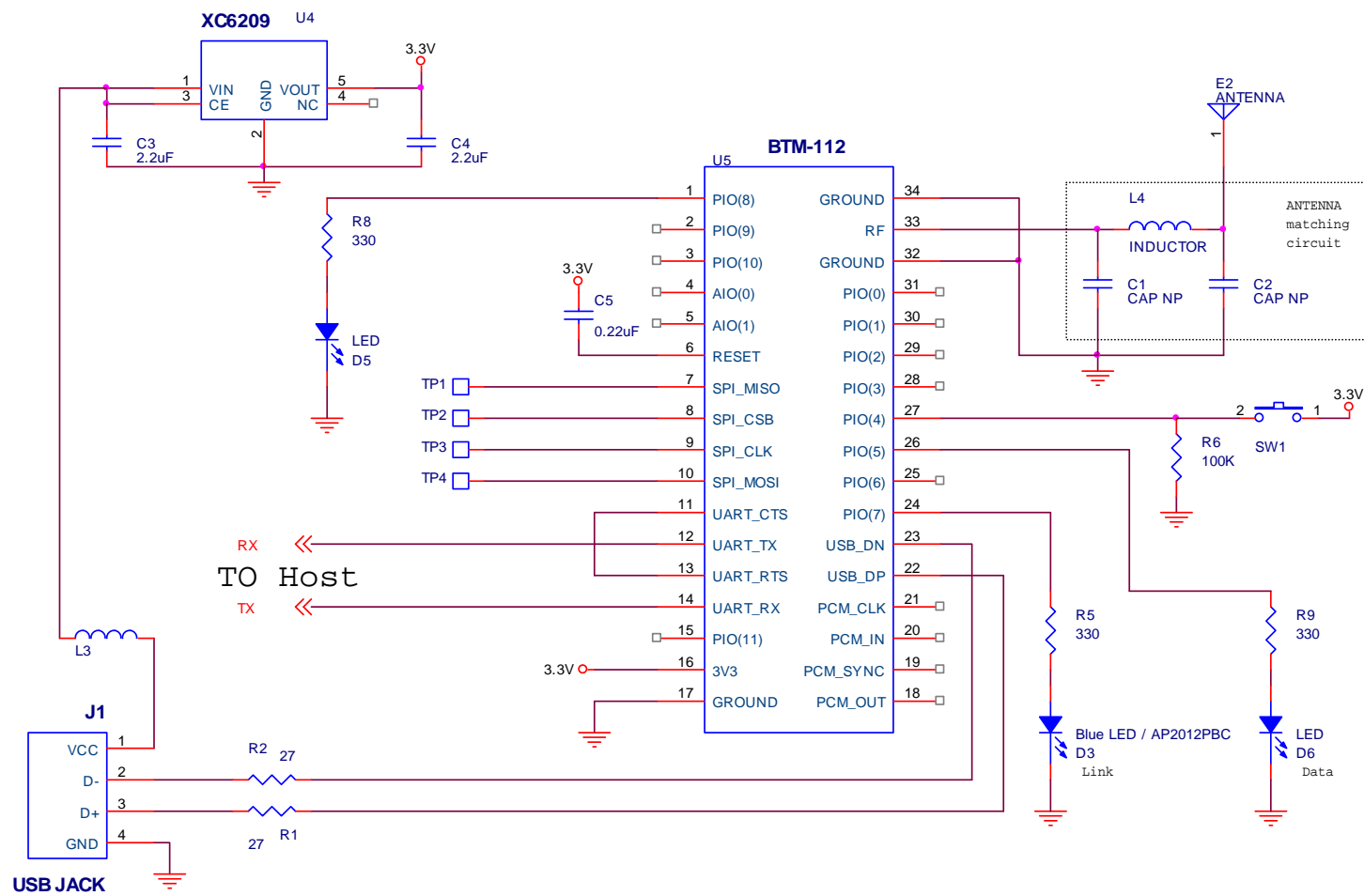

Title		
SPP MODULE APPLICATION		
Size	Document Number	Rev
A	<Doc>	XX
Date:	Monday, February 18, 2008	Sheet 1 of 1

## AT Command sets

<p>+++ (Escape Sequence)</p>	<p>When the device is in Data mode, it can be forced back into Command mode while maintaining the connection to the remote device. The sequence characters should be with 1000ms guard time.</p>	
<p>A (Establish connection)</p>	<p>This command is used to establish a connection in manual master role.</p>	
	<i>Modifiers</i>	<i>Description</i>
	A	Connect to a device which has been assigned by "ATD= xxxxxx"
<p>B (Display local BD address)</p>	<p>This command display the local device BD address</p>	
	<i>Modifiers</i>	<i>Description</i>
	B?	Inquire the Local BD address
<p>C (Flow Control)</p>	<p>This command enable or disable flow control signals (CTS/RTS) of the COM port. Note, the setting is not affected by ATZ0 but will cause a reboot.</p>	
	<i>Modifiers</i>	<i>Description</i>
	C0	Disable flow control.
	C1 (Default)	Enable flow control.
<p>D (Set Remote BD address)</p>	<p>For security purpose, We can specifies the unique remote device can be connected. In master role, it automatically inquire and search the slave even the slave is undiscoverable. In slave role, the command should be as a filter condition to accept the master' s inquiry.</p>	
	<i>Modifiers</i>	<i>Description</i>
	D=xxxxxxxx	"xxxxxxxx" is a string of 12 hexadecimal digits
	D0 (Default)	Clear Remote BD address setting, inquire any slave in master mode or accept any master in slave mode.
<p>E (Local Echo)</p>	<p>This command specifies whether the device should echo characters received from the UART back to the Host in command mode.</p>	
	<i>Modifiers</i>	<i>Description</i>
	E0	Characters received from the UART will not echo back to the Host.
	E1 (Default)	Characters received from the UART will echo back to the Host.
<p>F (Find Bluetooth device)</p>	<p>This command is used to find any bluetooth device in neighborhood within 60 seconds timeout. If any device is found, its name and address will be listed. The search ends with a message "Inquiry ends, xx device(s) found." This command is available only when the adaptor is in the manual master role. An AT can cancel the Inquiry.</p>	
	<i>Modifiers</i>	<i>Description</i>
	F?	Inquire scan max. 8 Bluetooth <b>neighborhood</b> devices.
<p>H (Discoverable)</p>	<p>This command is used to drop the connection either master or slave role. And it is used to specify whether the adaptor can be discovered by remote devices. <b>Note, it will cause a reboot when ATH0 or ATH1 take effect.</b></p>	
	<i>Modifiers</i>	<i>Description</i>

Control)	H	Drop current connection in Online command mode.	
	H0	The device enters undiscoverable mode. If a pair have been made, the original connection could be connected again. Other remote master device can not discovery this device.	
	H1 (Default)	The device enters discoverable mode.	
	H?	Inquire the current setting	
I (Information)	This command is used to inquiry the information.		
	<i>Modifiers</i>	<i>Description</i>	
	I0	Inquire the version Codes	
	I1	List all current setting value.	
	I2	Inquire RSSI in Online Command mode	
K (Stop setting)	bits	This command is used to specify one or two stop bits of COM port	
		<i>Modifiers</i>	<i>Description</i>
		K0 (Default)	One Stop bit
		K1	Two stop bits
		K?	Inquire the current setting
L (Baud Rate Control)	This command is used to specify the baud rate of COM port		
	<i>Modifiers</i>	<i>Description</i>	
	L#	1200bps	
	L*	2400bps	
	L0	4800bps	
	L1	9600bps	
	L2 (Default)	19200bps	
	L3	38400bps	
	L4	57600bps	
	L5	115200bps	
	L6	230.4Kbps	
	L7	460.8Kbps	
	L8	921.6Kbps	
	L?	Inquire the current setting	
M (Parity setting)	bits	This command is used to specify the parity bit setting of COM port	
		<i>Modifiers</i>	<i>Description</i>
		M0 (Default)	None Parity bit.
		M1	Odd parity setting.
		M2	Even parity setting
		M?	Inquire the current setting
N (Set name)	device	We can specifies the device a friendly name using 0 to 9, A to Z, a to z, space and - , which are all valid characters. Note that "firs space or -, last space or - isn' t permitted". The default name is "Serial Adaptor"	
		<i>Modifiers</i>	<i>Description</i>
		N=xxxxx	"xxxxx" is a character string, maxima length is 16

	N?	Inquire the device name
<b>O</b> (Auto connect setting)	This command is used to enable/disable auto-connection feature in master mode. By the way, it is used to online switch from command mode to data mode. Note, it will cause a reboot when ATH0 or ATH1 take effect.	
	<i>Modifiers</i>	<i>Description</i>
	O	Online switch from Command mode to Data mode.
	<b>O0</b> (Default)	<b>Automatically</b> connecting to a device which is assigned in "ATD=xxxx" or any available device if "ATD=" was not assigned.
	O1	Disable auto-connection feature, user should manually use "ATA" command to connect a remote device.
	O?	Inquire the current setting
<b>P</b> (Set PIN code)	This command specifies the PIN number. It control to off the PIN code authorization that allow to establish a connection without PIN code. Default PIN number is "1234"	
	<i>Modifiers</i>	<i>Description</i>
	<b>P=xxxx</b> (Default)	"xxxx" is 4~8 digit string
	<b>P0</b>	Turn off the PIN code authorization
	P?	Inquire the current PIN number
<b>Q</b> (Result Code Supression)	The command is used to determine if result Codes should be sent to the Host. When result Codes are supressed, the device does not generate any characters in response to the completion of a command or when an event occurs. Four Result Codes : OK,CONNECT,DISCONNECT,ERROR	
	<i>Modifiers</i>	<i>Description</i>
	<b>Q0</b> (Default)	The device will prompt Result Codes.
	Q1	The device will not prompt Result Codes.
	Q?	Inquire the current setting
<b>R</b> (Set Role)	This command specifies whether the device could be master or slave device. If change the role, the adaptor will reboot and clear all paired records.	
	<i>Modifiers</i>	<i>Description</i>
	<b>R0</b>	The device as master role.
	<b>R1</b> (Default)	The device as slave role.
	R?	Inquire the current setting
<b>X</b> (Escape Control)	This command is used to disable/enable escape sequence "+++".	
	<i>Modifiers</i>	<i>Description</i>
	<b>X0</b>	Disable escape character check.
	<b>X1</b>	Enable escape character check.
	<b>X?</b>	Inquire the current setting
<b>Z</b> (Restore)	This command is used to restore the default settings and reboot.	
	<b>Z0</b>	Restore the default setting.

The factory settings of UART are as follows:

- Baud rate: 19200 bps
- Data bit: 8
- Parity: none
- Stop bit: 1
- Flow control: H/W or none

### BTM-112 Pin Functions

PIN	NAME	TYPE	FUNCTION	REMARK
1	PIO(8)	Bi-directional	Programmable Input/Output line (Drive Power status led, active high, it will flash 3 times when it reboot).	
2	PIO(9)	Bi-directional	Programmable Input/Output line	
3	PIO(10)	Bi-directional	Programmable Input/Output line	
4	AIO0	Bi-directional	Programmable Input/Output Line	
5	AIO1	Bi-directional	Programmable Input/Output Line	
6	RESET	CMOS input	Reset if high. Input debounced so must be high for >5ms to cause a reset	
7	SPI_MISO	CMOS Output	Serial Peripheral Interface Data Output	
8	SPI_CSB	CMOS Input	Chip Select For Synchronous Serial Interface active low	
9	SPI_CLK	CMOS Input	Serial Peripheral Interface Clock	
10	SPI_MOSI	CMOS Input	Serial Peripheral Interface Data Input	
11	UART_CTS	CMOS Input	UART Clear To Send (Active Low)	
12	UART_TX	CMOS Output	UART Data Output	
13	UART_RTS	CMOS Output	UART Request To Send (Active Low)	
14	UART_RX	CMOS Input	UART Data Input	
15	PIO(11)	Bi-directional	Programmable Input/Output line	
16	3V3	Power	3.3V Power Supply Input	
17	GND	GND	Ground	
18	PCM_OUT	CMOS Output	Synchronous Data Output	
19	PCM_SYNC	Bi-directional	Synchronous Data Sync	
20	PCM_IN	CMOS Input	Synchronous Data Input	
21	PCM_CLK	Bi-directional	Synchronous Data Clock	
22	USB_DP	Bi-directional	USB Data Plus	
23	USB_DN	Bi-directional	USB Data Minus	
24	PIO(7)	Bi-directional	Programmable Input/Output line (Drive Link status led, active high, it will flash 3 times when it reboot).	
25	PIO(6)	Bi-directional	Programmable Input/Output line	
26	PIO(5)	Bi-directional	Programmable Input/Output line (Drive Data status led, active high, it will flash 3 times when it reboot)	
27	PIO(4)	Bi-directional	Programmable Input / Output Line (Button Input, active high)	
28	PIO(3)	Bi-directional	Programmable Input/Output Line	
29	PIO(2)	Bi-directional	Programmable Input / Output Line	
30	PIO(1)	Bi-directional	Programmable Input/Output Line	
31	PIO(0)	Bi-directional	Programmable Input / Output Line	
32	GND	GND	Ground	
33	RF_IO	Analogue	50 ohm Antenna connection	
34	GND	GND	Ground	



# BTM-11x Pin out Information

## PIN DETAILS VIEWED FROM TOP SIDE

1	34
PIO(8)	GND
PIO(9)	RF_IO
PIO(10)	GND
AIO(0)	PIO(0)
AIO(1)	PIO(1)
RESET	PIO(2)
SPI_MISO	PIO(3)
SPI_CSB	PIO(4)
SPI_CLK	PIO(5)
SPI_MOSI	PIO(6)
UART_CTS	PIO(7)
UART_TX	USB_DN
UART_RTS	USB_DP
UART_RX	PCM_CLK
PIO(11)	PCM_IN
3V3	PCM_SYNC
GND	PCM_OUT
17	18

## MODULE PAD AND SOLDER MASK DETAILS

SOLDER MASK WINDOW 1.0mm MAX

SOLDER PAD 0.8mm

## MECHANICAL DETAILS VIEWED FROM TOP/BOTTOM SIDE

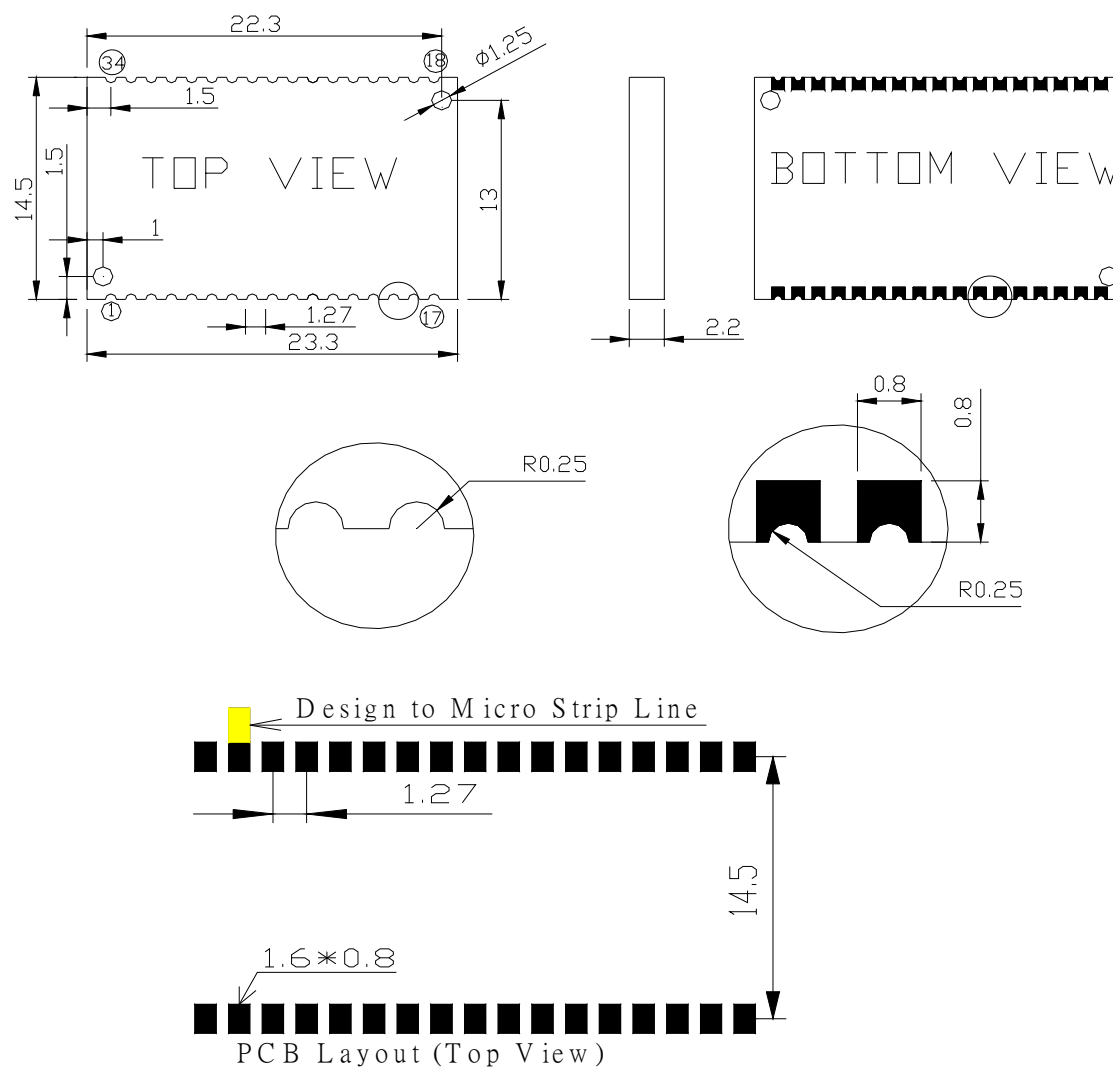

 **Bluetooth** Qualified Product Notice

Jan-Willem Vonk

Bluetooth Qualification Body (BQB)

TUV Rheinland Taiwan Ltd.

Applicant details	
Applicant	Rayson Technology Co., Ltd.
Address	1F, No.9, R&D Road, Science Based Industrial Park, Hsin-Chu, 300, Taiwan, R.O.C.
Person responsible	Tim Lin
Phone	+886 3 563 3666
Fax	+886 3 563 3688
E-mail	<a href="mailto:sales@mail.rayson.com">sales@mail.rayson.com</a>

Product information	
Product name	Bluetooth Class 2 CSR BC4-ext module
Product ID	BTM-11x
Hardware Version	A5
Software Version	Unified21d
Product category	Components
Product Type	Comp-HW-Integrated
Supported profiles	None
Product Description	BC4-ext Class 2 SMD type module

Reference documents	
Core Specification	Core V2.0 + EDR
Test Case Reference List	TCRL_EDR_2005-1-BQRB1, Release date: May 1st, 2005
Program Reference Document	Version 1.0 and First Addendum
Conformance Test Specification	See Annex A

Qualified Product Notice identification	
QPN Reference No.	BQ10016907
Date of Assessment	Jun 6, 2006
Date of Listing	Jun 6, 2006