

POWERTIP TECH. LTD.

DISPLAY DEVICES FOR BETTER ELECTRONIC DESIGN

Specification For Approval

液晶之光 电话: 020-33819057
[Http://www.lcdfriends.com](http://www.lcdfriends.com)

Customer : ELATEC

Model Type : LCD Module

Sample Code _____

Mass Production Code : PC2004LRU-CS0-B

Edit B

Customer Sign	Sales Sign	Approved By	Prepared By
			 09-29-99

CONTENTS

1. SPECIFICATIONS

- 1.1 Features
- 1.2 Mechanical Specifications
- 1.3 Absolute Maximum Ratings
- 1.4 DC Electrical Characteristics
- 1.5 Optical Characteristics
- 1.6 Backlight Characteristics

2. MODULE STRUCTURE

- 2.1 Counter Drawing
- 2.2 Interface Pin Description
- 2.3 Timing Characteristics
- 2.4 Display Command
- 2.5 Character Pattern



POWERTIP TECHNOLOGY CORPORATION

DISPLAY DEVICES FOR BETTER ELECTRONIC DESIGN

1. SPECIFICATIONS

1.1 Features

- 20-characters, four-lines liquid crystal display of 5*7dot matrix + cursor
- 1/16 Duty, 1/4 bias
- STN LCD, positive, yellow green
- Transflective LCD
- 6 o'clock viewing angle
- 8 bits parallel data input
- Built-in LED backlight

1.2 Mechanical Specifications

- Outline dimension : 77.0mm(L)* 47.0mm(W)* 14.2mm max.(H)
- Viewing area : 60.0mm *22mm
- Active area : 55.12mm *17.56mm
- Dot size : 0.42mm *0.46mm
- Dot pitch : 0.47mm *0.51mm
- Character Size : 2.3mm *4.03mm

1.3 Absolute Maximum Ratings

Item	Symbol	Conditions	Min.	Max.	Unit
Power supply Voltage	VDD	-	0	6.5	V
LCD drive Supply voltage	VDD-VO	-	0	13	V
Input voltage	VIN	-	-0.3	VDD+0.3	V
Operating temperature	TOPR	-	0	50	°C
Storage temperature	TSTG	-	-20	+70	°C
Humidity*1	HD	-	-	90	%RH

1.4 DC Electrical Characteristics

VDD=+5V±10%, VSS=0V, TA=25°C

Item	Symbol	Condition	Min.	Typ.	Max.	Unit
Logic Supply voltage	VDD	-	4.5	5	5.5	V
“H” input voltage	VIH	-	2.2	-	-	V
“L” input voltage	VIL	-	-	-	0.6	V
“H” output voltage	VOH	-	2.4	-	-	V
“L” output voltage	VOL	-	-	-	0.4	V
Supply current	IDD	VDD=5V	-	1.8	-	mA
LCD driving voltage	VOP	VDD-VO	-	4.6	-	V



POWERTIP TECHNOLOGY CORPORATION

DISPLAY DEVICES FOR BETTER ELECTRONIC DESIGN

1.5 Optical Characteristics

1/16 duty, 1/4 bias, $V_{op}=4.6V$, $T_a=25^\circ C$

Item	Symbol	Conditions	Min.	Typ.	Max	Reference
Viewing angle	θ	$C \geq 2.0, \phi = 0^\circ$	30°	-	-	Notes 1 & 2
Contrast	C	$\theta = 5^\circ, \phi = 0^\circ$	3	4.5	-	Note 3
Response time(rise)	t_r	$\theta = 5^\circ, \phi = 0^\circ$	-	120ms	180ms	Note 4
Response time(fall)	t_f	$\theta = 5^\circ, \phi = 0^\circ$	-	250ms	400ms	Note 4

Note 1: Definition of angles θ and ϕ

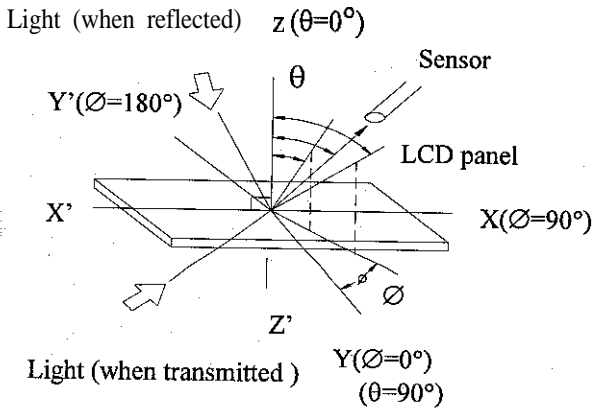

Note 2: Definition of viewing angles θ_1 and θ_2

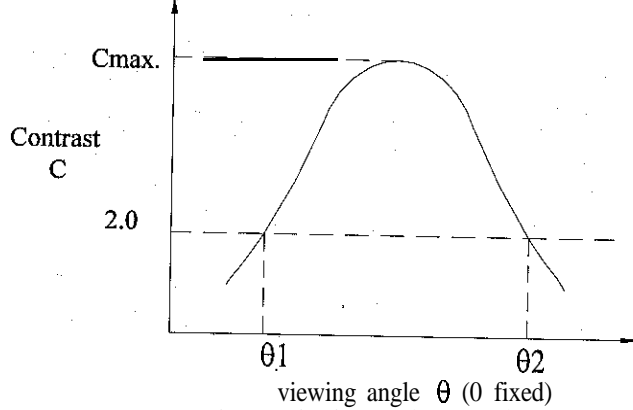

Note : Optimum viewing angle with the naked eye and viewing angle θ at C_{max} . Above are not always the same

Note 3: Definition of contrast C

$$c = \frac{\text{Brightness (reflection) of unselected dot (B2)}}{\text{Brightness (reflection) of selected dot (B1)}}$$

Note 4: Definition of response time

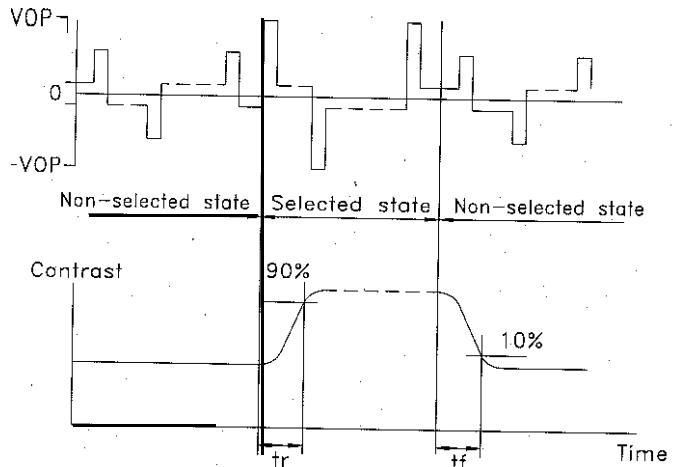
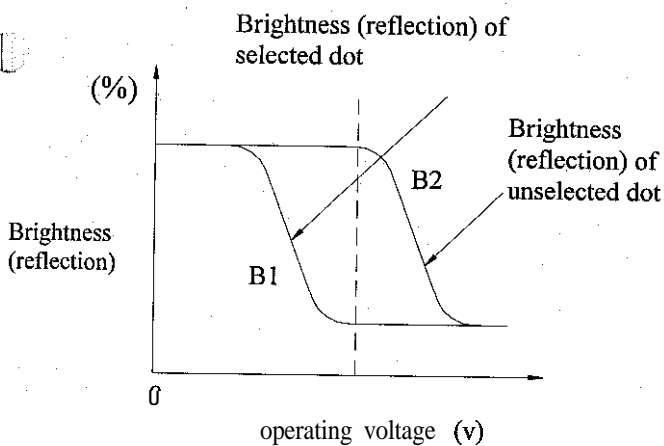

Note: Measured with a transmissive LCD panel which is displayed 1 cm²

V_{OPR} : operating voltage
 T_r : Response time (rise)

f_{FRM} : Frame frequency
 t_f : Response time (fall)



POWERTIP TECHNOLOGY CORPORATION

DISPLAY DEVICES FOR BETTER ELECTRONIC DESIGN

1.6 Backlight Characteristic

The LCD Module is backlight using a edge LED panel

- .Maximum Ratings

Item	Symbol	Conditions	Min.	Max.	Unit
Forward current	IF	TA=25°C	-	375	mA
Reverse voltage	VR	TA=25°C	-	8	V
Power dissipation	PO	TA=25°C	-	1.72	W
Operating Temperature	TOPR	-	-20	70	°C
Storage temperature	TSTG	-	-40	80	°C

- .Electrical Ratings

Item	Symbol	Condition	Min.	Typ.	Max.	Unit
Forward voltage	VF	IF=150mA	-	4.2	4.6	V
Reverse current	IR	VR=8V	-	-	0.2	mA
Luminous intensity	IV	IF=150mA	200	250	-	cd/m ²
Wavelength	λ_p	IF=150mA	571	-	576	nm
Color	Yellow Green					

2. MODULE STRUCTURE

2.1 Counter Drawing

*See Appendix

2.2 Interface Pin Description

Pin No.	Symbol	Signal Description
1	VSS	Signal ground (GND)
2	VDD	Power Supply (5 V)
3	VO	Operating voltage (LCD Driver)
4	RS	Register Selection input High = Data register Low = Instruction register (for write) Busy flag address counter (for read)
5	R/W	Read/Write signal input is used to select the read/write mode High = Read mode, Low = Write mode
6	E	Start enable signal to read or write the data
7~10	DB0 ~ DB3	Four low order bi-directional three-state data bus lines. Use for data transfer between the MPU and the LCD module. These four are not used during 4-bit operation.
11~14	DB4 ~ DB7	Four high order bi-directional three-state data bus lines. Used for data transfer between the MPU and the LCD module. DB7 can be used as a busy flag.
15	A	Power supply for LED B / L (+)
16	K	Power supply for LED B / L (-)

Contrast Adjust

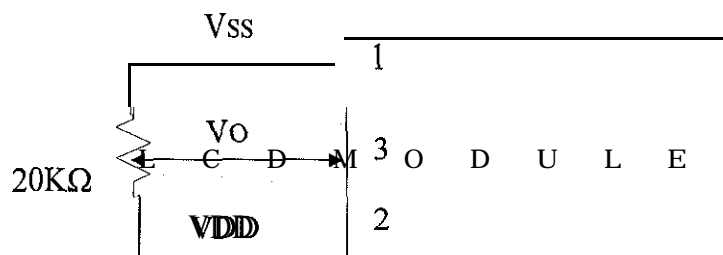

2.3 Timing Characteristics

• Read cycle

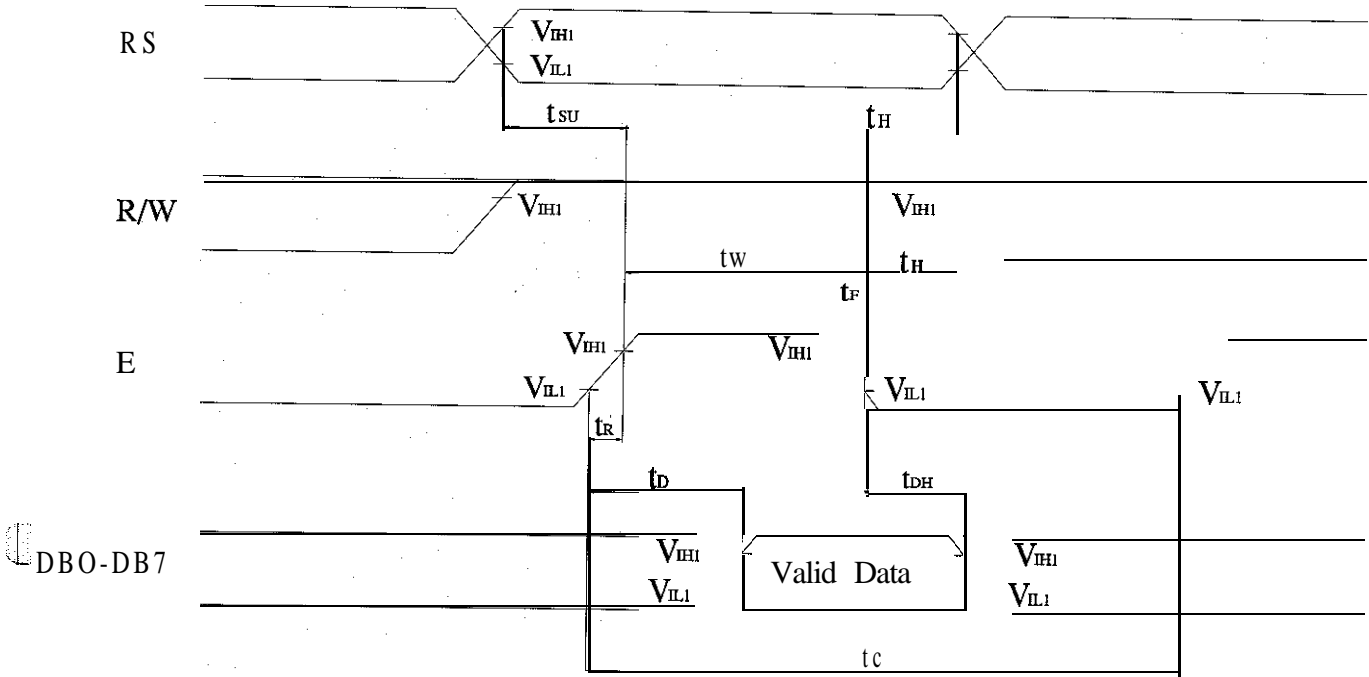

• Write cycle

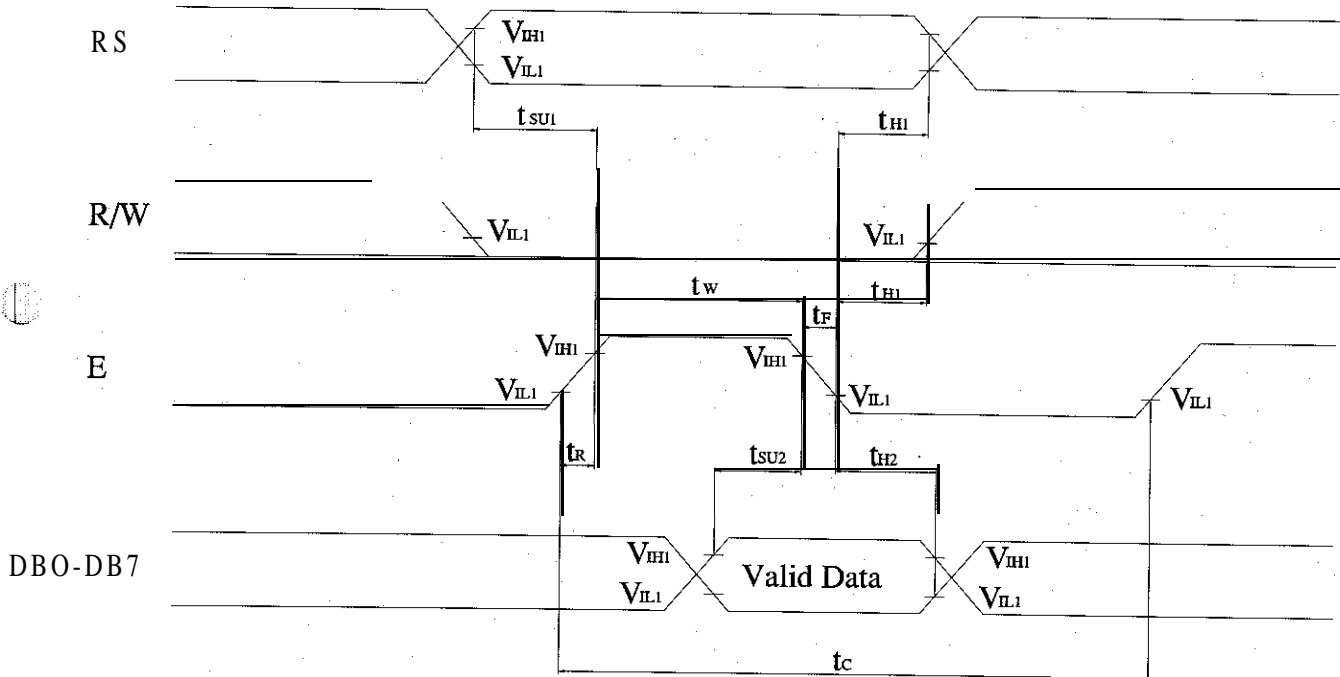

• Read cycle

 $V_{DD}=4.5V\sim 5.5V, T_a=-30\sim +85^{\circ}C$

Characteristics	Symbol	Min.	Typ.	Max.	Unit
E Cycle Time	t_C	500	-	-	ns
E Rise / Fall Time	t_R, t_F	-	-	20	ns
E Pulse Width (High, Low)	t_W	230	-	-	ns
R/W and RS Setup Time	t_{SU}	40	-	-	ns
R/W and RS Hold Time	t_H	10	-	-	ns
Data Output Delay Time	t_D	-	-	120	ns
Data Hold Time	t_{DH}	5	-	-	ns

• Write cycle

Characteristics	Symbol	Min.	Typ.	Max.	Unit
E Cycle Time	t_C	500	-	-	ns
E Rise / Fall Time	t_R, t_F	-	-	20	ns
E Pulse Width (High, Low)	t_W	230	-	-	ns
R/W and RS Setup Time	t_{SU1}	40	-	-	ns
R/W and RS Hold Time	t_{H1}	10	-	-	ns
Data Setup Time	t_{SU2}	80	-	-	ns
Data Hold Time	t_{H2}	10	-	-	ns

2.4 Display Command

Instructions	Instruction Code										Description	Execution Time (fosc=270KHZ)
	RS	R/W	DB7	DB6	DB5	DB4	DB3	DB2	DB1	DB0		
Clear Display	0	0	0	0	0	0	0	0	0	1	Write "20H" to DDRAM. and set DDRAM address to "00H" from AC.	1.52ms
Return Home	0	0	0	0	0	0	0	0	1	X	Set DDRAM address to "OOH" from AC and return cursor to it's original position if shifted. The contents of DDRAM are not changed.	1.52ms
Entry Mode Set	0	0	0	0	0	0	0	1	I/D	SH	Assign cursor moving direction and make shift of entire display enable.	37µs
Display ON/OFF Control	0	0	0	0	0	0	1	D C B (Sets display(D), cursor(C), and blinking of cursor(B) on/off control bit.			37µs	
cursor or Display Shift	0	0	0	0	0	1	SIC	R/L	×	X	Set cursor moving and display shift control bit, and the direction, without changing of DDRAM data.	37µs
Function Set	0	0	0	0	1	DL	N	F	×	X	Set interface data length (DL:4-bit/S-bit), numbers of display line (N:1-line/2-line), display font type(F:5*8 dots/5*11-dots)	37µs
Set CGRAM Address	0	0	0	1	AC5	AC4	AC3	AC2	AC1	AC0	Set CGRAM address in address counter.	37µs
Set DDRAM Address	0	0	1	AC6	AC5	AC4	AC3	AC2	AC1	AC0	Set DDRAM address in address counter.	37µs
Read Busy Flag and Address	0	1	BF	AC6	AC5	AC4	AC3	AC2	AC1	AC0	Whether during internal operation or not can be known by reading BF. The contents of address counter can also be read.	0µs
Write Data to RAM	1	0	D7	D6	D5	D4	D3	D2	D1	DO	Write data into internal RAM (DDRAM/CGRAM).	43µs
Read Data from RAM	1	1	D7	D6	D5	D4	D3	D2	D1	DO	Read data from internal RAM (DDRAM/CGRAM).	43µs

※ "×":don't care

2.5 Character Pattern

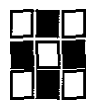

POWERTIP TECHNOLOGY CORPORATION
DISPLAY DEVICES FOR BETTER ELECTRONIC DESIGN

CHARACTER PATTERN (HO / EA / SO)

Upper 4bit Lower 4bit	LLLL	LLHL	LLHH	LHLL	LHLH	LHHL	LHHH	HLLL	HLLH	HLHL	HLLH	HHLH	HHLH	HHLH	HHLH
LLLL	CG RAM (1)														
LLHH	(2)														
LLHL	(3)														
LLHH	(4)														
LHLL	(5)														
LHLH	(6)														
LHHL	(7)														
LHHH	(8)														
HLLL	(1)														
HLLH	(2)														
HLHL	(3)														
HLHH	(4)														
HHLH	(5)														
HHLH	(6)														
HHLH	(7)														
HHLH	(8)														

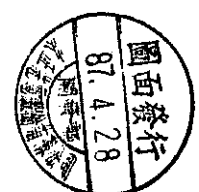
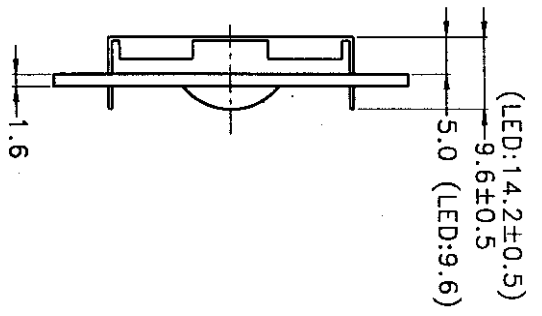
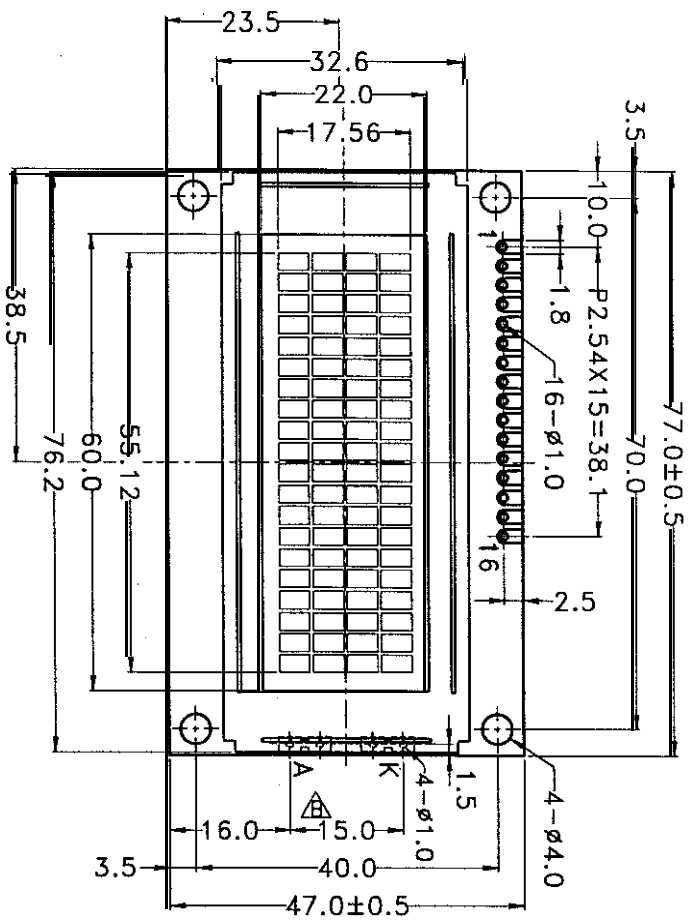

PIN NO.	SIGNAL
1	VSS
2	Vdd
3	Vo
4	RS
5	R/W
6	E
7	DB0
8	DB1
9	DB2
10	DB3
11	DB4
12	DB5
13	DB6
14	DB7
15	A
16	K

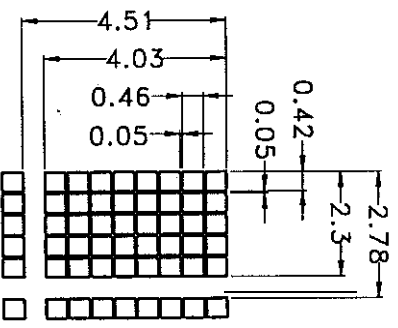
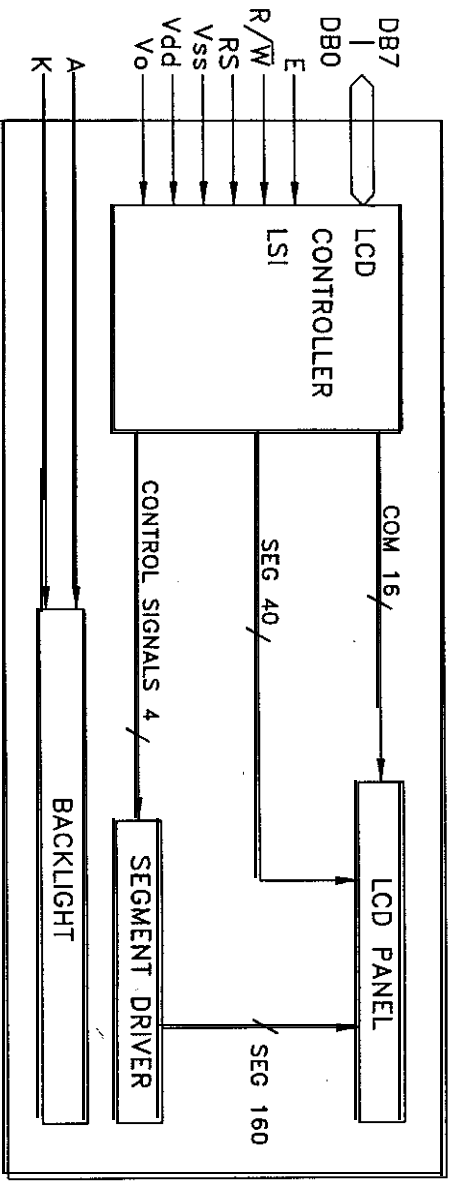

The tolerance unless classified ±0.3mm

SCALE: 6/1

POWER TIP TECHNOLOGY

SCALE: 1/1	MODEL NAME: PC 2004-C
UNIT: mm	TITLE: COUNTER DRAWING
EDI: PAGE: 1/1	DRAWN NO. PC-95040
APPROVED: [Signature]	CHECKER: [Signature]
DATE: 3/5/98	DRAWN: 87.3.3