

UTC TL1451 LINEAR INTEGRATED CIRCUIT

DUAL PULSE-WIDTH-MODULATION CONTROL CIRCUITS

DESCRIPTION

The UTC TL1451 incorporates on a single monolithic chip all the functions required in the construction of two pulse-width-modulation (PWM) control circuits. Designed primarily for power supply control, the TL1451 contains an on-chip 2.5V regulator, two error amplifiers, an adjustable oscillator, two dead-time comparators, undervoltage lockout circuitry, and dual common-emitter output transistor circuits.

FEATURES

- *Complete PWM Power control Circuitry
- *Completely Synchronized Operation
- *Internal Undervoltage Lockout Protection
- *Wide Supply Voltage Range
- *Internal Short-Circuit Protection
- *Oscillator Frequency .500kHz Max
- *Variable Dead Time Provides Control Over Total Range
- *Internal Regulator Provides a Stable 2.5V Reference Supply

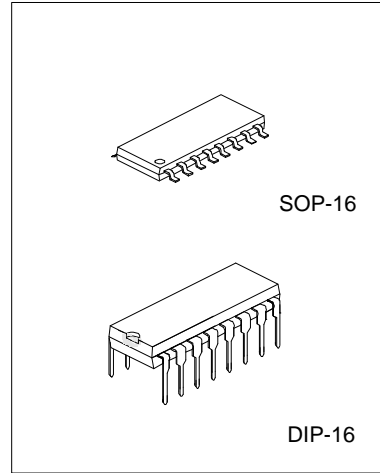

PIN CONFIGURATIONS

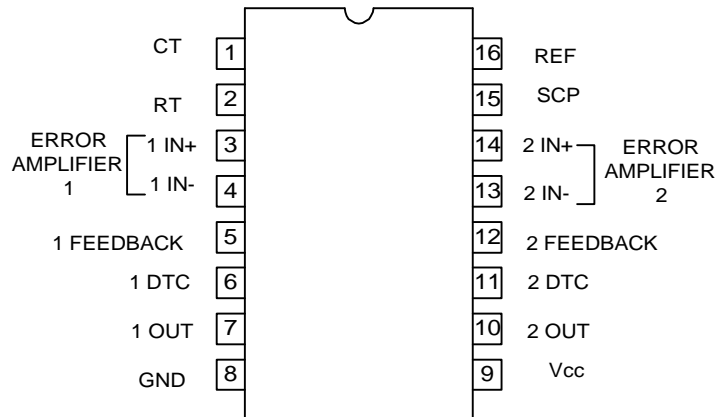

UTC TL1451 LINEAR INTEGRATED CIRCUIT

BLOCK DIAGRAM

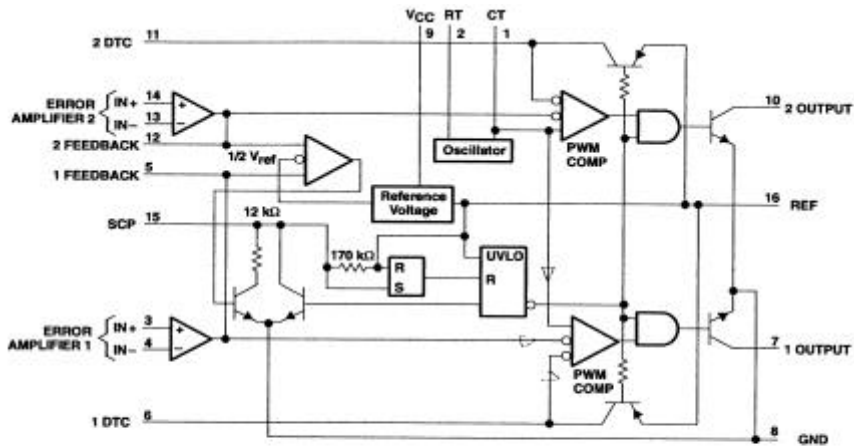

UTC TL1451 LINEAR INTEGRATED CIRCUIT

ABSOLUTE MAXIMUM RATINGS(Unless otherwise noted all is over operating free air temperature range)

PARAMETER	SYMBOL	VALUE	UNIT
Supply Voltage	V_{CC}	51	V
Amplifier Input Voltage	V_I	20	V
Collector Output Voltage	V_O	51	V
Collector Output Current	I_O	21	mA
Power Dissipation : $T_A \leq 25^\circ\text{C}$			mW
DIP		1000	
SOP		500	
Operating free-air Temperature Range	T_A	-20 TO 85	$^\circ\text{C}$
Storage Temperature Range	T_{stg}	-65 TO 150	$^\circ\text{C}$
Lead Temperature 1.6mm from Case for 10 Sec.	T_{case}	260	$^\circ\text{C}$

RECOMMENDED OPERATING CONDITIONS

PARAMETER	SYMBOL	VALUE		UNIT
		MIN	MAX	
Supply Voltage	V_{CC}	3.6	50	V
Amplifier Input Voltage	V_I	1.05	1.45	V
Collector Output Voltage	V_O		50	V
Collector Output Current(each Transistor)	I_O		20	mA
Current into Feedback Terminal			45	μA
Feedback Resistor	R_F	100		$k\Omega$
Timing Capacitor	C_T	150	15000	pF
Timing Resistor	R_T	5.1	100	$k\Omega$
Oscillator frequency		1	500	kHz
Operating Free-Air Temperature	T_A	-20	85	$^\circ\text{C}$

ELECTRICAL CHARACTERISTICS

(Over recommended operating free-air temperature range, $V_{CC}=6\text{V}$, $f=200\text{kHz}$, $T_A=25^\circ\text{C}$, Unless otherwise specified)

PARAMETER	TEST CONDITIONS	MIN	TYP	MAX	UNIT
Reference Section					
Output Voltage	$I_O=1\text{mA}$	2.4	2.5	2.6	V
Output Voltage Change with Temperature	$T_A=-20^\circ\text{C}$ to 25°C $T_A=25^\circ\text{C}$ to 85°C		-0.1	$\pm 1\%$	
			-0.2	$\pm 1\%$	
Input Voltage Regulation	$V_{CC}=3.6\text{V}$ to 40V		2	12.5	mV
Output Voltage Regulation	$I_O=0.1\text{mA}$ to 1mA		1	7.5	mV
Short-Circuit Output Current	$V_O=0$	3	10	30	mA
Undervoltage Lockout Section					
Upper Threshold Voltage (V_{CC})	$I_O(\text{ref})=0.1\text{mA}$, $T_A=25^\circ\text{C}$		2.72		V
Lower Threshold Voltage (V_{CC})			2.6		V
Hysteresis (V_{CC})		80	120		mV
Reset Threshold voltage (V_{CC})		1.5	1.9		V
Short-Circuit Protection Control Section					
Input Threshold Voltage(SCP)	$T_A=25^\circ\text{C}$	0.65	0.7	0.75	V

UTC TL1451 LINEAR INTEGRATED CIRCUIT

PARAMETER	TEST CONDITIONS	MIN	TYP	MAX	UNIT
Standby Voltage(SCP)	No pullup	140	185	230	mV
Latched Input Voltage (SCP)	No pullup		60	120	mV
Input (source) Current	VI=0.7V,TA=25°C	-10	-15	-20	μA
Comparator Threshold Voltage (FEEDBACK)			1.18		V
Oscillator Section					
Frequency	CT=330pF, RT=10kΩ		200		kHz
Standard deviation of frequency	CT=330pF, RT=10kΩ		10%		
Frequency Change with Voltage	Vcc=3.6V to 40V		1%		
Frequency Change with Temperature	TA=-20°C to 25°C TA=25°C to 85°C		-0.4% -0.2%	±2% ±2%	
Dead-Time Control Section					
Input bias Current (DTC)				1	μA
Latch mode (source) Current (DTC)	TA=25°C	-80	-145		μA
Latched Input Voltage (DTC)	Io=40μA	2.3			V
Input threshold Voltage at f=10kHz (DTC)	Zero duty cycle Maximum duty cycle	1.2	2.05 1.45	2.25	V
Error-Amplifier Section					
Input Offset Voltage	Vo (FEEDBACK)=1.25V			±6	mV
Input Offset Current	Vo (FEEDBACK)=1.25V			±100	nA
Input Bias current	Vo (FEEDBACK)=1.25V		160	500	nA
Common-Mode Input Voltage Range	Vcc=3.6V to 40V	1.05 to 1.45			V
Open-loop Voltage Amplification	RF=200kΩ	70	80		dB
Unity-gain Bandwidth			1.5		MHz
Common-mode Rejection Ratio		60	80		dB
Positive Output Voltage Swing		Vref- 0.1			V
Negative Output Voltage Swing				1	V
Output (sink) Current (FEEDBACK)	VID=-0.1V,Vo=1.25V	0.5	1.6		mA
Output (source) Current (FEEDBACK)	VID=-0.1V,Vo=1.25V	-45	-70		μA
Output Section					
Collector off-state Current	Vo=50V			10	μA
Output Saturation Voltage	Io=10mA		1.2	2	V
Short-Circuit Output Current	Vo=6V		90		mA
PWM Comparator Section					
Input Threshold Voltage at f=10kHz (FEEDBACK)	Zero duty cycle Maximum duty cycle	1.2	2.05 1.45	2.25	V
TOTAL DEVICE					
Standby Supply Current	Off-state		1.3	1.8	mA
Average Supply Current	RT=10kΩ		1.7	2.4	mA

UTC TL1451 LINEAR INTEGRATED CIRCUIT

TEST CIRCUIT

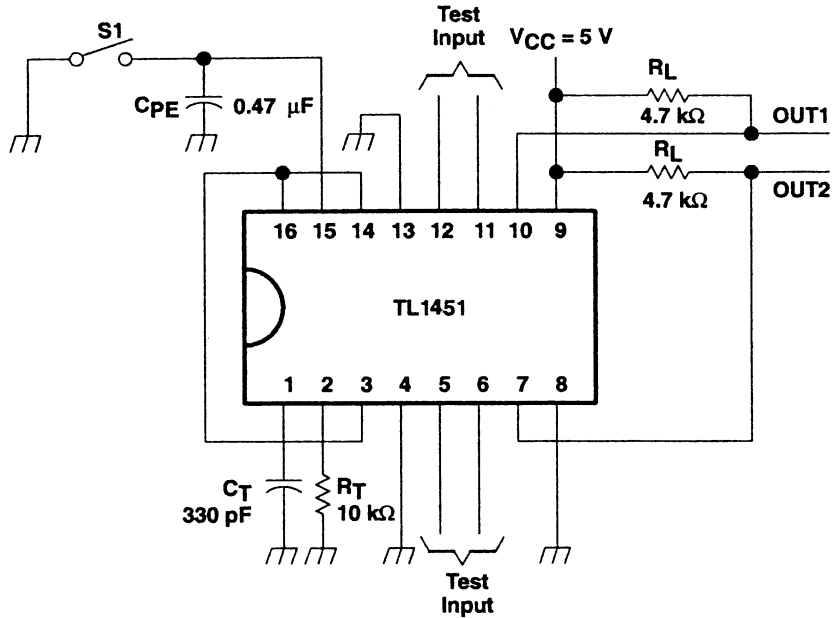

TIMING DIAGRAM

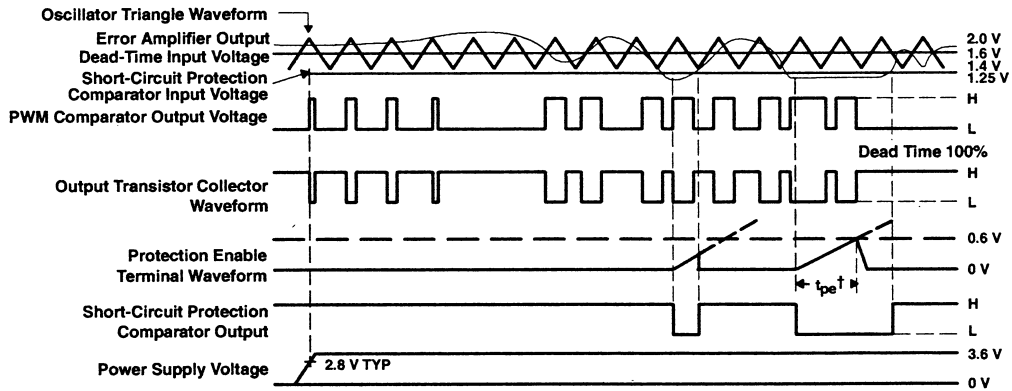

† Protection Enable Time, $t_{pe} = (0.051 \times 10^6 \times C_{pe})$ in seconds