

TCB6963

LCD Module Controller Board User Manual

Shenzhen Topway Electronics Co., Ltd.

Rev.	Descriptions	Release Date
1.0	New release	19-Mar-03

Table of Content

1. Basic Specifications	3
1.1 Product Highlight.....	3
1.2 Mechanical Specifications.....	3
1.3 Block Diagram.....	3
1.4 Terminal Functions.....	4
2. Absolute Maximum Ratings	5
3. Electrical Characteristics	5
3.1 DC Characteristics.....	5
3.2 AC Characteristics.....	5
Please refer to TOSHIBA T6963C for details.....	5
4. Function Specifications	6
4.1 Hard-wired Setting.....	6
4.2 Command and Data format.....	6
5. Design and Handling Precaution	6

1. Basic Specifications

1.1 Product Highlight

- 1) TCB6963 is a LCD Module Controller Board using Toshiba T6963C LCD controller
- 2) On board 64k byte memory
- 3) Speed up the development of using T6963 controller
- 3) Suitable for medium size (serial data stream) LCD module
- 4) Direct interface between MCU and LCD module
- 5) Designed for TOPWAY LM24064B or equivalent
- 6) Built in 128-word character generator ROM
- 7) 8bit MCU interface
- 8) Hardware selectable font size 5x8 or 8x8 dots

1.2 Mechanical Specifications

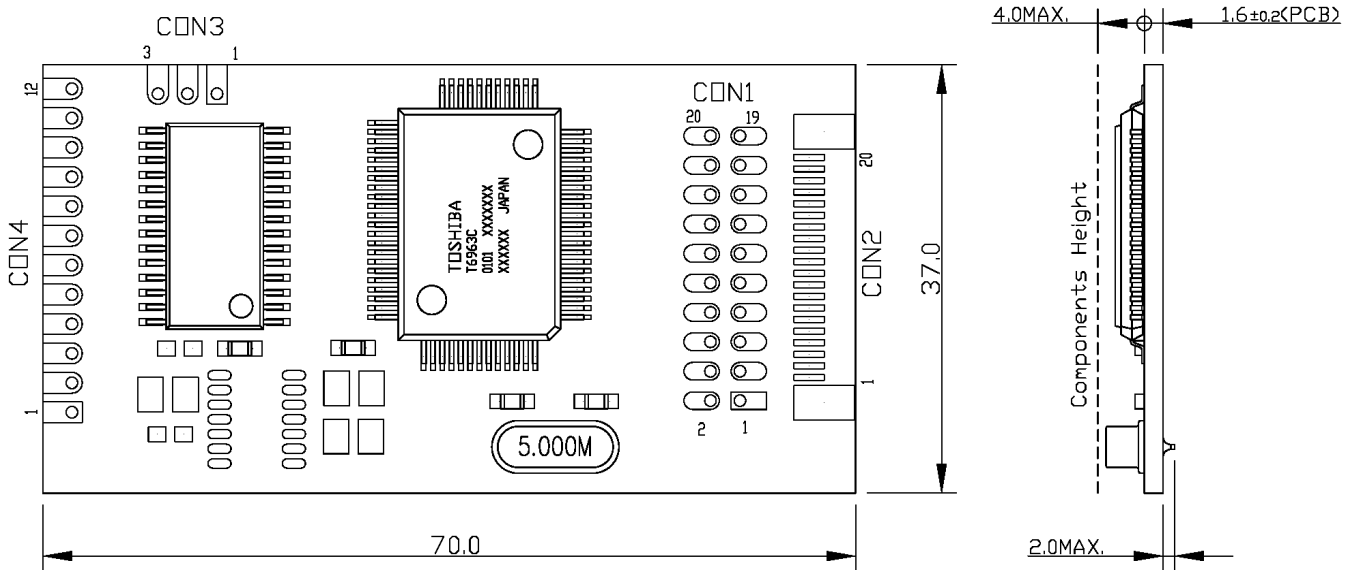

- CON1 : suitable for 20pin IDC connector (P2.54mm)
- CON2 : suitable for 20pin FFC connector (P1.0mm)
- CON3 : suitable for 3 pin SIL header (P2.54mm)
- CON4 : suitable for 12pin SIL header (P2.54mm)

1.3 Block Diagram

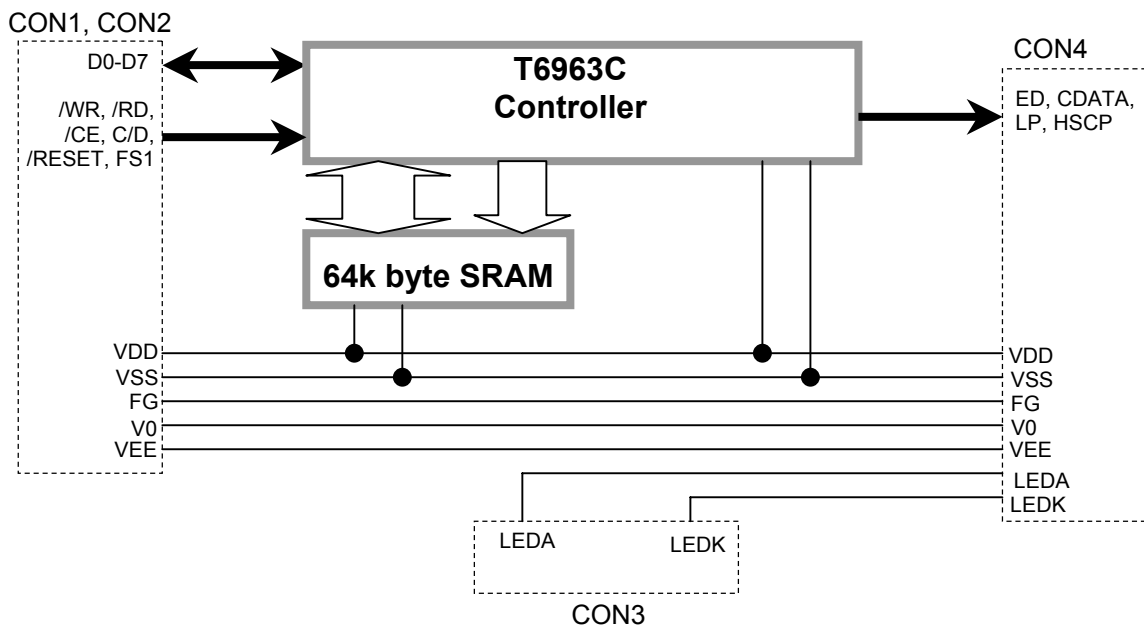

1.4 Terminal Functions

CON1 & CON2 (MCU Terminal) (*1)

Pin No.	Pin Name	I/O	Descriptions
1	FG	Passive	Direct connected to CON4.6 (FG)
2	VSS	Power	Negative Power Supply (0V) Direct Connected to CON4.8 (VSS)
3	VDD	Power	Positive Power Supply (5V) Direct Connected to CON4.7 (VDD)
4	V0	Passive	Direct connected to CON4.10 (V0)
5	/WR	Input	Data Write, Write data into TCB6963 when /WR=L
6	/RD	Input	Data Read, Read data from TCB6963 when /RD=L
7	/CE	Input	Chip Enable for TCB6963, /CE must be L when CPU communicates with TCB6963
8	C/D	Input	C/D=H, /WR=L, /RD=H : Command Write C/D=H, /WR=H, /RD=L : Status Read C/D=L, /WR=L, /RD=H : Data Write C/D=L, /WR=H, /RD=L : Data Read
9	NC	-	No connection
10	/RESET	Input	/RESET=H : Normal (built-in internal pull-up resistor) /RESET=L : Initialize TCB6963, Text and graphic have addresses and text and graphic area settings are retained
11~18	D0~D7	Bi-Direction	Data I/O pins between MCU and TCB6963
19	FS1	Input	Pins for font selection FS1=H : 6x8 font FS1=L : 8x8 font
20	VEE	Passive	Direct connected to CON4.9 (VEE)

Note: *1. CON1 and CON2 are identical and direct connected

CON3 (Backlight Supply Terminal) (*1)

Pin No.	Pin Name	I/O	Descriptions
1	LEDA	Passive	Direct connected to CON4.11 (LEDA)
2	NC	-	No connection
3	LEDK	Passive	Direct connected to CON4.12 (LEDK)

CON4 (LCD Module Terminal) (*1)

Pin No.	Pin Name	I/O	Descriptions
1	ED	Output	Data output for columns in both upper and lower areas of LCD
2	CDATA	Output	Synchronous signal for row driver
3	NC	-	No connection
4	LP	Output	Latch pulse for column driver. Shift clock pulse for row driver
5	HSCP	Output	Shift clock pulse for column driver for upper area of LCD
6	FG	Passive	Direct connected to CON1.1 (FG)
7	VDD	Power	Direct connected to CON1.3 (VDD) (5V), Power supply for LCD module.
8	VSS	Power	Direct connected to CON1.2 (VSS) (0V), Power supply for LCD module.
9	VEE	Passive	Direct connected to CON1.20 (VEE)
10	V0	Passive	Direct connected to CON1.4 (V0)
11	LEDA	Passive	Direct connected to CON3.1 (LEDA)
12	LEDK	Passive	Direct connected to CON3.3 (LEDK)

2. Absolute Maximum Ratings

Items	Symbol	Min.	Max.	Unit	Condition
Supply Voltage	V_{DD}	-0.3	6.0	V	$V_{SS} = 0V$
Input Voltage	V_{IN}	$V_{SS}-0.3$	$V_{DD}+0.3$	V	$V_{SS} = 0V$
Operating Temperature	T_{OP}	0	50	°C	No Condensation
Storage Temperature	T_{ST}	-10	60	°C	No Condensation

Cautions:

Any Stresses exceeding the Absolute Maximum Ratings may cause substantial damage to the device. Functional operation of this device at other conditions beyond those listed in the specification is not implied and prolonged exposure to extreme conditions may affect device reliability.

3. Electrical Characteristics

3.1 DC Characteristics

$V_{SS}=0V, V_{DD}=5V, T_{OP}=25^{\circ}C$

Items	Symbol	MIN.	TYP.	MAX.	Unit	Applicable Pin
Operating Voltage	V_{DD}	4.5	5.0	5.5	V	VDD
Input High Voltage	V_{IH}	$V_{DD}-0.5$	-	VDD	V	Input pins
Input Low Voltage	V_{IL}	0	-	0.5	V	Input pins
Output High Voltage	V_{OH}	$V_{DD}-0.5$	-	VDD	V	Output pins
Output Low Voltage	V_{OL}	0	-	0.5	V	Output pins
Input Pull-up Resistor	R_{PU}	50	-	200	$K\Omega$	/RESET
Operating Frequency	f_{OSC}	-	5.0	-	MHz	-
Operating Current	I_{DD}	-	-	12.0	mA	VDD

3.2 AC Characteristics

Please refer to TOSHIBA T6963C for details

4. Function Specifications

TOPWAY TCB6963 is using Toshiba T6963C. Please refer to its specification for functional details.

4.1 Hard-wired Setting

The following is the internal hard-wired setting inside TCB6963:

Setting / Connection	Descriptions
/HALT = H	Normal running
MDS = L MD0 = L MD1 = L	2 Screen, 16 lines, 128 V-Dots
MD2 = L MD3 = H	40 columns
FS0 = L	Make FS1 function as described in Section 1.4
/DUAL = H	Single Scan
SDSEL = L	Sending data by simple serial method

Note: These setting / connection is based on on-board T6963C pin name

4.2 Command and Data format

Please refer to TOSHIBA T6963C for details.

5. Design and Handling Precaution

1. Any mechanical shock (eg. dropping from high place) will damage the device.
2. Do not add excessive force on the device.
3. Never attempt to disassemble or rework the device.
4. When mounting the device, make sure that it is free from twisting, warping and distortion.
5. Only hold the device by its side.
6. Never add force to component of the device. It may cause invisible damage or degrade of the reliability.
7. This could be easily damaged by static electricity. Be careful to maintain an optimum anti-static work environment to protect it.
8. Take care and prevent get hurt by the device sharp edge.
9. Never operate the device exceed the absolute maximum ratings.
10. Keep the signal line as short as possible to prevent noisy signal applying to the device.
11. Never apply signal to the device without power supply.
12. Device reliability may be reduced by temperature shock.
13. When storing the device, avoid exposure to the direct sunlight, high humidity, high temperature or low temperature.