

ESPRIT 728+ PROGRAMMING GUIDE



SOFTWARE VERSION 3.10

KEYPAD TROUBLE DISPLAY

Key "ON" -

- | | |
|----------------------------|-----------------------------------|
| [1] No battery/low voltage | [7] Communication report failure |
| [2] Power failure | [8] Timer loss* |
| [4] Bell disconnect | [9] Tamper or zone wiring failure |
| [5] Maximum bell current | [10] Telephone line failure |
| [6] Max auxiliary current | [11] Fire loop trouble |

* To clear timer loss trouble, see Key Access Programming (MEM).
Press [CLEAR] to clear troubles.

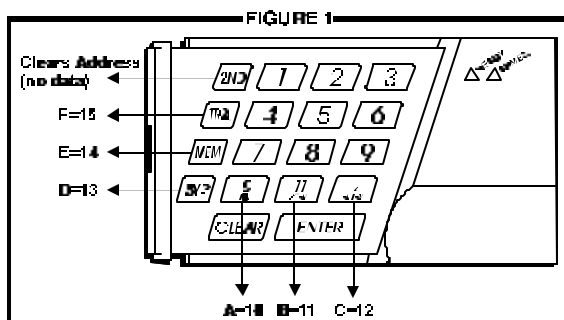
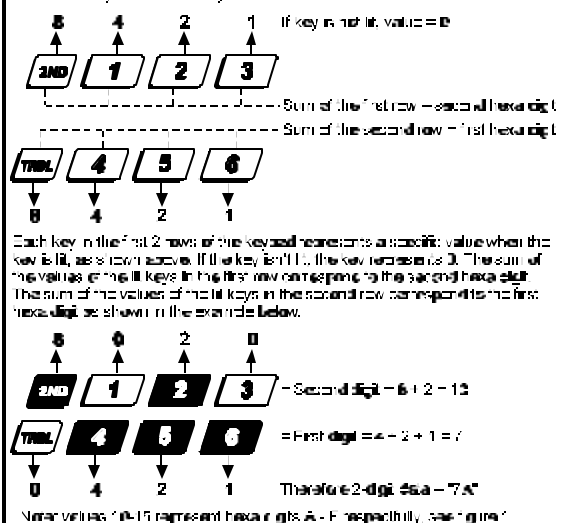

FIGURE 2 HEXA DIGIT DATA DISPLAY FOR LED KEYPADS

Note: LED keypads will display current data on the screen.



HEXA PROGRAMMING:

Addresses 000 to 043 and 300 to 527 are programmed using the Hexa Programming method. In this mode, you can enter any hexa-digit from 0-F where keys [1] to [9] represent digits 1 to 9 respectively; the other keys represent hexa digits A to F as shown in figure 1. To program using the Hexa Programming method:

- 1) Press [ENTER] + *Installer Code (default: 282828)*
- 2) The [ENTER] key will flash indicating you are in programming mode
- 3) Enter the desired 3-digit address
- 4) The keypad will display the 2-digit data currently saved at this address as described in figure 2
- 5) Enter 2-digit data; after entering data you do not need to press [ENTER], the software will automatically save the data into the selected address
- 6) Return to **step 2** or press [CLEAR] to exit programming mode

STREAMLINED SECTION PROGRAMMING

This is an alternate method to Hexa Programming. The addresses (000-043 and 300-527) programmed in the Hexa Programming method are grouped into 67 sections where each section contains four addresses (i.e. section 00 = addresses 000-003). Using this method allows you to program 8 digits (4 addresses) without having to exit and re-enter addresses. Note, the keypad will not display the current data in the Hexa Streamlined Programming method. To program using the Hexa Streamlined Section method:

- 1) Press [ENTER] + *Installer code (default: 282828)* + [7]
- 2) The [ENTER] and [2ND] keys will flash to indicate you are in programming mode
- 3) Enter **2-digit section** (00-67)
- 4) The [ENTER] key will remain on while the [2ND] key will be off
- 5) Enter **8-digit data** to program the section
- 6) The keypad will "beep" to indicate that the section has been programmed, data is saved and the software has advanced to the next section
- 7) Return to **step 4** or press [CLEAR] to exit programming mode

INSTALLER CODE (Default 282828)

Full access to programming, except user access codes. No access to arming/disarming. Use only numeric keys from [1] to [10]. (key [10] = 0)

PANEL ANSWER OPTIONS

First digit disables "Answering Machine Override" (key [2ND] or key [1]), or determines period of time between first and second call (see table below). Second digit determines number of rings required before panel will answer. If [2ND][2ND] is entered, panel will not answer. (Default value is [2ND] [8].)

Streamline section	Data	Description	Address	ANSWERING MACHINE OVERRIDE [2ND] or [1] = disabled [5] = 40 seconds [2] = 16 seconds [6] = 48 seconds [3] = 24 seconds [7] = 56 seconds [4] = 32 seconds [8] to [F] = 60 seconds
00	___/___	Installer code (1st, 2nd digit)	000	
	___/___	Installer code (3rd, 4th digit)	001	
	___/___	Installer code (5th, 6th digit)	002	
	___/___	Panel answer options	003	
	Number of rings (Max. 15)			

Streamline section	Data	Description	Address	
01	___/___	Panel identifier (1st, 2nd digit)	004	} identifies the control panel to the PC.
	___/___	Panel identifier (3rd, 4th digit)	005	
	___/___	PC password (1st, 2nd digit)	006	} identifies the PC to the panel.
	___/___	PC password (3rd, 4th digit)	007	

TELEPHONE AND ACCOUNT NUMBERS

If only one central station phone number is used, program the same number for telephone number 1 and 2. If only one account number is required, the same number must be entered for both account "A" and "B". (No Default)

- [10] = the number "0"
- [11] = *
- [12] = #
- [BYP] = switch from pulse to tone while dialing
- [MEM] = pause 4 seconds
- [TRBL] = end of number

COMPUTER TELEPHONE NUMBER (View at addresses 008 to 015.)

Streamline section	Streamline section
02 ___/___/___/___/___/___/___/___	03 ___/___/___/___/___/___/___/___
1 2 3 4 5 6 7 8	9 10 11 12 13 14 15 16

Press [TRBL] to end phone number if less than 16 digits are programmed.

CENTRAL STATION TELEPHONE NUMBER 1 (View at addresses 016 to 023.)

Streamline section	Streamline section
04 ___/___/___/___/___/___/___/___	05 ___/___/___/___/___/___/___/___
1 2 3 4 5 6 7 8	9 10 11 12 13 14 15 16

Press [TRBL] to end phone number if less than 16 digits are programmed.

CENTRAL STATION TELEPHONE NUMBER 2 (View at addresses 024 to 031.)

Streamline section	Streamline section
06 ___/___/___/___/___/___/___/___	07 ___/___/___/___/___/___/___/___
1 2 3 4 5 6 7 8	9 10 11 12 13 14 15 16

Press [TRBL] to end phone number if less than 16 digits are programmed.

ACCOUNT "A" AND "B": (View at addresses 032 to 035.)

Streamline section	Streamline section
08 ___/___/___/___ ___/___/___/___	
1 2 3 4 5 6 7 8	
A	B

For 3 digit account numbers, enter "skip" [2ND] as first digit.

Streamline section	Data	Description	Address
09	[2ND]/[2ND]	Future use	036
	[2ND]/___	1st digit: value must be entered i.e. [2ND]	037
	___/___	2nd digit: time correction (See table)	038
	___/___	1st digit: telephone 1 format	
	___/___	2nd digit: telephone 2 format	
___/[2ND]	1st digit: PGM type	039	
10	___/___	PGM 1	040
	[2ND]/[2ND]	Future Use	041
	___/___	PGM mask 1	042
	[2ND]/[2ND]	Future Use	043

TIME CORRECTION: (address 037 second digit)	
[2nd] - No adjustment	[8] - Minus 4 sec.
[1] - Plus 4 sec.	[9] - Minus 8 sec.
[2] - Plus 8 sec.	[10] - Minus 12 sec.
[3] - Plus 12 sec.	[11] - Minus 16 sec.
[4] - Plus 16 sec.	[12] - Minus 20 sec.
[5] - Plus 20 sec.	[byp] - Minus 24 sec.
[6] - Plus 24 sec.	[MEM] - Minus 28 sec.
[7] - Plus 28 sec.	[TRBL] - Minus 32 sec.

COMMUNICATOR FORMATS

Key

[2ND] = ADEMCO slow (1400Hz, 1900Hz, 10bps)	[6] = RADIONICS with PARITY (1400Hz, 40bps)
[1] = (1400Hz, 1800Hz, 10bps)	[7] = RADIONICS with PARITY (2300Hz, 40bps)
[2] = SILENT KNIGHT fast (1400Hz, 1900Hz, 20bps)	[8] = *ADEMCO express
[3] = SESCOA (2300Hz, 1800Hz, 20bps)	[9] = *ADEMCO contact ID (programmable codes)
[4] = RADIONICS (40bps with 1400Hz handshake)	[10] = *ADEMCO contact ID (all codes)
[5] = RADIONICS (40bps with 2300Hz handshake)	[TRBL] = *DTMF - no handshake (personal dialing)
	* = 4-Digit Codes Only

PROGRAMMABLE CONTACT ID EVENT CODES

All addresses from 300 to 527 (sections 11 to 67) programmed with values other than [2ND] [2ND] will report the contact ID codes corresponding to the values programmed. Values to be programmed should be selected from this table.

CID	REPORTING CODE	PROG. VALUE	CID	REPORTING CODE	PROG. VALUE
100:	AUXILIARY ALARM	[2nd] / [1]	300:	SYSTEM TROUBLE	[2] / [2]
110:	FIRE ALARM	[2nd] / [2]	301:	AC LOSS	[2] / [3]
111:	FIRE SMOKE	[2nd] / [3]	302:	LOW SYSTEM BATTERY	[2] / [4]
112:	COMBUSTION	[2nd] / [4]	305:	SYSTEM RESET	[2] / [5]
113:	WATER FLOW	[2nd] / [5]	306:	PROGRAM CHANGED	[2] / [6]
114:	HEAT	[2nd] / [6]	309:	BATTERY TEST FAIL	[2] / [7]
115:	PULLSTATION	[2nd] / [7]	320:	SOUNDER/RELAY TROUBLE	[2] / [8]
116:	DUCT	[2nd] / [8]	321:	BELL 1 TROUBLE	[2] / [9]
117:	FLAME	[2nd] / [9]	323:	ALARM RELAY TROUBLE	[2] / [10]
118:	NEAR ALARM	[2nd] / [10]	350:	COMMUNICATION TROUBLE	[2] / [11]
120:	PANIC ALARM	[2nd] / [11]	351:	TELCO 1 FAULT	[2] / [12]
121:	DURESS	[2nd] / [12]	354:	FAIL TO COMMUNICATE	[2] / [byp]
122:	SILENT PANIC	[2nd] / [byp]	370:	PROTECTION LOOP TROUBLE	[2] / [MEM]
123:	AUDIBLE PANIC	[2nd] / [MEM]	371:	PROTECTION LOOP OPEN	[2] / [TRBL]
130:	BURGLARY	[2nd] / [TRBL]	372:	PROTECTION LOOP SHORT	[3] / [2nd]
131:	PERIMETER BURG.	[1] / [2nd]	373:	FIRE LOOP TROUBLE	[3] / [1]
132:	INTERIOR BURG.	[1] / [1]	382:	SENSOR TROUBLE	[3] / [2]
133:	24HR BURGLARY	[1] / [2]	383:	SENSOR TAMPER	[3] / [3]
136:	BURGLARY OUTDOOR	[1] / [3]	400:	OPEN/CLOSE	[3] / [4]
137:	BURGLARY TAMPER	[1] / [4]	401:	OPEN/CLOSE BY USER	[3] / [5]
138:	BURGLARY NEAR ALARM	[1] / [5]	402:	GROUP OPEN/CLOSE	[3] / [6]
140:	GENERAL ALARM	[1] / [6]	403:	AUTOMATIC OPENING/CLOSING	[3] / [7]
150:	24 HOUR AUX	[1] / [7]	404:	LATE TO OPEN/CLOSE	[3] / [8]
151:	GAS DETECTED	[1] / [8]	407:	REMOTE ARM DOWNLOAD	[3] / [9]
152:	REFRIGERATION	[1] / [9]	410:	REMOTE ACCESS	[3] / [10]
153:	LOSS OF HEAT	[1] / [10]	441:	OPEN/CLOSE - STAY MODE	[3] / [11]
154:	WATER LEAKAGE	[1] / [11]	570:	BYPASS	[3] / [12]
155:	FOIL BREAK ALARM	[1] / [12]	572:	24 HOUR ZONE BYPASS	[3] / [byp]
156:	DAY TROUBLE ALARM	[1] / [byp]	573:	BURGLARY BYPASS	[3] / [MEM]
157:	LOW GAS LEVEL	[1] / [MEM]	574:	GROUP BYPASS	[3] / [TRBL]
158:	HIGH TEMPERATURE	[1] / [TRBL]	601:	MANUAL TEST	[4] / [2nd]
159:	LOW TEMPERATURE	[2] / [2nd]	602:	PERIODIC TEST	[4] / [1]
161:	LOSS AIR FLOW	[2] / [1]	675:	TIME/DATE RESET	[4] / [2]

For addresses 044 to 126, see pages 7 to 10.

REPORTING CODES: All digits from [1] to [F] are valid. [2Nd] = digit will not be reported except for contact I.D. programmable codes. For single digit reporting enter "skip" ([2Nd]) as first digit. (Default = "empty" [2Nd] [2Nd])

If CONTACT I.D. format (all codes) is selected, addresses 300 to 527 (sections 11- 67) do not have to be programmed. (Select Contact I.D. (all codes) - key [10] for both central station numbers at section 09 - address 038.)

ARMING (closing) CODES:

Streamline section	Data	Description	Address	Streamline section	Data	Description	Address
11	___/___	Auto / Esplod	300	18	___/___	User code 27	328
	___/___	Master	301		___/___	User code 28	329
	___/___	User code 1	302		___/___	User code 29	330
	___/___	User code 2	303		___/___	User code 30	331
12	___/___	User code 3	304	19	___/___	User code 31	332
	___/___	User code 4	305		___/___	User code 32	333
	___/___	User code 5	306		___/___	User code 33	334
	___/___	User code 6	307		___/___	User code 34	335
13	___/___	User code 7	308	20	___/___	User code 35	336
	___/___	User code 8	309		___/___	User code 36	337
	___/___	User code 9	310		___/___	User code 37	338
	___/___	User code 10	311		___/___	User code 38	339
14	___/___	User code 11	312	21	___/___	User code 39	340
	___/___	User code 12	313		___/___	User code 40	341
	___/___	User code 13	314		___/___	User code 41	342
	___/___	User code 14	315		___/___	User code 42	343
15	___/___	User code 15	316	22	___/___	User code 43	344
	___/___	User code 16	317		___/___	User code 44	345
	___/___	User code 17	318		___/___	User code 45	346
	___/___	User code 18	319		___/___	User code 46	347
16	___/___	User code 19	320	23	___/___	User code 47	348
	___/___	User code 20	321		___/___	User code 48 /	349
	___/___	User code 21	322			(Duress)	
	___/___	User code 22	323				
17	___/___	User code 23	324	→ See next page			
	___/___	User code 24	325				
	___/___	User code 25	326				
	___/___	User code 26	327				

REPORTING CODES: *(reset code "empty")*

DISARMING (opening) CODES:

Streamline section	Data	Description	Address	Streamline section	Data	Description	Address
	→ See previous page						
23	/	Esplod	350	30	/	User code 25	376
	/	Master	351		/	User code 26	377
24	/	User code 1	352		/	User code 27	378
	/	User code 2	353		/	User code 28	379
	/	User code 3	354	31	/	User code 29	380
	/	User code 4	355		/	User code 30	381
25	/	User code 5	356		/	User code 31	382
	/	User code 6	357		/	User code 32	383
	/	User code 7	358	32	/	User code 33	384
	/	User code 8	359		/	User code 34	385
26	/	User code 9	360		/	User code 35	386
	/	User code 10	361		/	User code 36	387
	/	User code 11	362	33	/	User code 37	388
	/	User code 12	363		/	User code 38	389
27	/	User code 13	364		/	User code 39	390
	/	User code 14	365		/	User code 40	391
	/	User code 15	366	34	/	User code 41	392
	/	User code 16	367		/	User code 42	393
28	/	User code 17	368		/	User code 43	394
	/	User code 18	369		/	User code 44	395
	/	User code 19	370	35	/	User code 45	396
	/	User code 20	371		/	User code 46	397
29	/	User code 21	372		/	User code 47	398
	/	User code 22	373		/	User code 48 /	399
	/	User code 23	374	(Duress)			
	/	User code 24	375				

ALARM CODES ZONES 1 TO 10:

Streamline section	Data	Description	Address
36	/	Zone 1	400
	/	Zone 2	401
	/	Zone 3 <i>(fire add. 100)</i>	402
	/	Zone 4	403
37	/	Zone 5	404
	/	Zone 6	405
	/	Zone 7	406
	/	Zone 8	407
38	/	Zone 9	408
	/	Zone 10	409
	[2ND] / [2ND]	Future Use	410
	[2ND] / [2ND]	Future Use	411

Addresses 410-423 reserved for future use.

ZONES 1 TO 10 RESTORE CODES:

Streamline section	Data	Description	Address
42	/	Zone 1	424
	/	Zone 2	425
	/	Zone 3 <i>(fire add. 100)</i>	426
	/	Zone 4	427
43	/	Zone 5	428
	/	Zone 6	429
	/	Zone 7	430
	/	Zone 8	431
44	/	Zone 9	432
	/	Zone 10	433
	[2ND] / [2ND]	Future Use	434
	[2ND] / [2ND]	Future Use	435

Addresses 434-447 reserved for future use

REPORTING CODES: (reset code "empty")

ZONES 1 TO 10 SHUTDOWN CODES:

Streamline section	Data	Description	Address
48	___/___	Zone 1	448
	___/___	Zone 2	449
	___/___	Zone 3	450
	___/___	Zone 4	451
49	___/___	Zone 5	452
	___/___	Zone 6	453
	___/___	Zone 7	454
	___/___	Zone 8	455
50	___/___	Zone 9	456
	___/___	Zone 10	457
	[2ND]/[2ND]	Future Use	458
	[2ND]/[2ND]	Future Use	459

Addresses 458-471 reserved for future use

TAMPER 1 TO 7 TROUBLE CODES:

Streamline section	Data	Description	Address
54	___/___	Tamper 1 (ATZ)	472
	___/___	Tamper 2	473
	___/___	Tamper 3 (ATZ)	474
	___/___	Tamper 4	475
55	___/___	Tamper 5 (ATZ)	476
	[2ND]/[2ND]	Future Use	477
	___/___	Tamper 7 (ATZ)	478
	[2ND]/[2ND]	Future Use	479

Addresses 480-495 reserved for future use

TROUBLE CODES:

Streamline section	Data	Description	Address
60	___/___	Max. auxiliary current	496
	___/___	Bell disconnect / max. bell current	497
	___/___	Battery disconnect / low voltage	498
	___/___	Power failure	499
	___/___		

Streamline section	Data	Description	Address
61	___/___	Fire loop trouble	500
	___/___	Timer loss	501
	[2ND]/[2ND]	Future use	502
	[2ND]/[2ND]	Future use	503

TROUBLE RESTORE CODES:

Streamline section	Data	Description	Address
62	___/___	Max. auxiliary current	504
	___/___	Bell disconnect	505
	___/___	Battery disconnect / low voltage	506
	___/___	Power failure	507
	___/___		

Streamline section	Data	Description	Address
63	___/___	Fire loop trouble	508
	___/___	Timer programmed	509
	___/___	Tamper / wiring fault	510
	___/___	TLM trouble restore	511

SPECIAL CODES:

Streamline section	Data	Description	Address
64	___/___	Test report	512
	___/___	Panic 1	513
	___/___	Panic 2	514
	___/___	Panic 3	515
65	___/___	Late to close	516
	___/___	No movement	517
	___/___	Partial arming	518
	___/___	Recent close	519

Streamline section	Data	Description	Address
66	___/___	Duress	520
	[2ND]/[2ND]	Future use	521
	[2ND]/[2ND]	Future use	522
	[2ND]/[2ND]	Future use	523
67	___/___	Log-in (Espload)	524
	___/___	Program change	525
	[2ND]/[2ND]	Future use	526
	[2ND]/[2ND]	Future use	527

DECIMAL PROGRAMMING

- 1) Press [ENTER] + *Installer Code (default: 282828)*
- 2) The [ENTER] key will flash to indicate you are in programming mode
- 3) Enter **3-digit address** (044-061)
- 4) The keypad will now display the current 3-digit data currently saved at this address as described in figure 3
- 5) Enter **3-digit data** (000-255) value; after entering data you do not need to press [ENTER], the software will automatically save the data into the selected address
- 6) Return to **step 2** or press [CLEAR] to exit programming mode

044: __/__/__ (hours) Auto arm time (between "000" and "023")

045: __/__/__ (minutes) Auto arm time (between "000" and "059")

046: __/__/__ (days) Auto test report every ? days (between "001" and "255") (000 = disabled)

047: __/__/__ (hours) Auto test report (between "000" and "023")

048: __/__/__ (minutes) Auto test report (between "000" and "059")

049: __/__/__ (seconds) Exit delay (*factory default 60 seconds*)

050: __/__/__ (seconds) Entry delay 1 (*factory default 45 seconds*)

051: __/__/__ (seconds) Entry delay 2 (*factory default 45 seconds*)

052: __/__/__ (minutes) Bell cut-off time (*factory default 5 minutes*)

053: __/__/__ (x 15 mSec.) Zone speed (*factory default 600 mSec.*)

054: __/__/__ (minutes) Power failure report delay (*factory default 30 minutes*) (000 = disabled)

055: __/__/__ (x 15 minutes) "No movement" report time (*factory default 8 hours*) (000 = disabled)

056: __/__/__ PGM timer setting (001 to 127 for seconds and 129 to 255 for minutes) (*factory default 5 seconds*)
Add 128 to desired value in minutes (i.e. for 5 minutes: enter 5 + 128 = 133)

057: __/__/__ Intellizone delay (in seconds, minimum = 10 seconds) (*factory default 48 seconds*)

058: __/__/__ Installer code lock (147 = locked, 000 = unlocked)

059: __/__/__ (seconds) Programmable delay before alarm transmission (5 to 63 seconds) (000 = disabled)

060: __/__/__ (seconds) Recent closing delay (000 = disabled)

061: __/__/__ Future Use

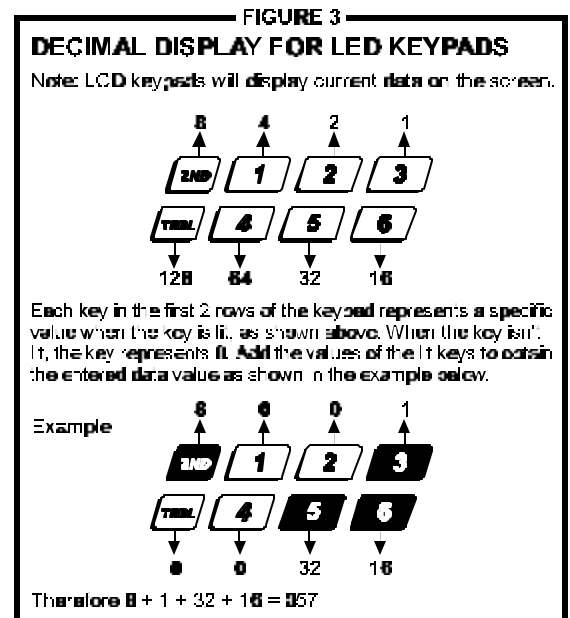

FEATURE SELECT PROGRAMMING

Addresses 062 to 126 are programmed using the Feature Select Programming method. In this method, every key on the keypad in each address represents an option or feature. Pressing a key will display it on the keypad and pressing it again will extinguish the key. The On/Off status of each key determines the selected feature. To program using the Feature Select Programming method:

- 1) Press [ENTER] + *Installer Code (default: 282828)*
- 2) The [ENTER] key will flash to indicate you are in programming mode
- 3) Enter **3-digit address** (062-126)
- 4) After entering the address, the keypad will display the feature selection status. Turn the keys On/Off by pressing the appropriate key until the desired options are set. Then press the [ENTER] key to accept, there will be a confirmation "beep" indicating the options have been accepted. The [ENTER] key will flash to indicate that the software is awaiting the next address entry
- 5) Return to **step 3** to continue programming or press [CLEAR] to exit programming mode

CODE PRIORITY																		
KEY SELECT: [1] [2] [3] [4] [5] [6] [7] [8] [9] [10] [11] [12] [BYT] [VEW] [MUL] [2-10]																		
062:	SYSTEM "A" / STAY	User #:	1	2	3	4	5	6	7	8	9	10	11	12	13	14	15	16
064:	SYSTEM "A" / STAY	User #:	17	18	19	20	21	22	23	24	25	26	27	28	29	30	31	32
066:	SYSTEM "A" / STAY	User #:	33	34	35	36	37	38	39	40	41	42	43	44	45	46	47	48
068:	SYSTEM "B" / AWAY	User #:	1	2	3	4	5	6	7	8	9	10	11	12	13	14	15	16
070:	SYSTEM "B" / AWAY	User #:	17	18	19	20	21	22	23	24	25	26	27	28	29	30	31	32
072:	SYSTEM "B" / AWAY	User #:	33	34	35	36	37	38	39	40	41	42	43	44	45	46	47	48
074:	Codes with bypass access	User #:	1	2	3	4	5	6	7	8	9	10	11	12	13	14	15	16
076:	Codes with bypass access	User #:	17	18	19	20	21	22	23	24	25	26	27	28	29	30	31	32
078:	Codes with bypass access	User #:	33	34	35	36	37	38	39	40	41	42	43	44	45	46	47	48

Addresses 080 to 085 for future use.

FEATURE SELECT PROGRAMMING (continued)

(On/off status of key lights determines which feature is selected.)

086:

See "TLM" table -----

- PS1/Keyswitch = regular arm -----
- PS1/keys switch arming -----
- Call back -----
- Auto arm on line -----
- Auto arm on no movement -----
- Pulse dialing -----
- Partitioning -----
- Silent zone/panic generates a silent alarm (1:2) Pulse Europe -----

See "Reporting" table -----

N/A

- Bell squawk on arm/disarm -----
- Auto zone shutdown -----

088:

- Automatic event buffer transmission -----
- Panic 1 (keys [1] & [3], PS1) -----
- Panic 2 (keys [4] & [6]) -----
- Panic 3 (keys [7] & [9]) -----
- Panic 1 silent (PS1) -----
- Panic 2 silent -----
- Panic 3 silent -----
- Key [10] regular arm -----
- Key [11] stay or system A arm -----
- 6 digit access codes -----

Tamper Recognition -----

- Beep on exit delay -----
- Report zone restore on bell cut-off -----
- Zones with EOL (1KΩ) -----
- Always report disarm -----

090:

- Exclude power failure from trouble display -----
- Zone 4 enabled -----
- Auto arm = regular arm -----

N/A

N/A

N/A

No tamper bypass -----

N/A

Zone doubling (ATZ) -----

Audible trouble warning -----

Duress -----

Keypad 1 zone supervision -----

Keypad 2 zone supervision -----

N/A

N/A

N/A

KEY		OFF	/	ON	
<input type="checkbox"/>	[2ND]	<input type="checkbox"/>		<input type="checkbox"/>	stay arm / System A
<input type="checkbox"/>	[1]	<input type="checkbox"/>		<input type="checkbox"/>	enabled
<input type="checkbox"/>	[2]	<input type="checkbox"/>		<input type="checkbox"/>	enabled
<input type="checkbox"/>	[3]	<input type="checkbox"/>		<input type="checkbox"/>	enabled
<input type="checkbox"/>	[4]	<input type="checkbox"/>		<input type="checkbox"/>	enabled
<input type="checkbox"/>	[5]	<input type="checkbox"/>		<input type="checkbox"/>	enabled
<input type="checkbox"/>	[6]	<input type="checkbox"/>		<input type="checkbox"/>	enabled
<input type="checkbox"/>	[7]	<input type="checkbox"/>		<input type="checkbox"/>	Tone dialing (DTMF)
<input type="checkbox"/>	[8]	<input type="checkbox"/>		<input type="checkbox"/>	enabled
<input type="checkbox"/>	[9]	<input type="checkbox"/>		<input type="checkbox"/>	generates only a report (1:1.5) Pulse USA
<input type="checkbox"/>	[10]	<input type="checkbox"/>		<input type="checkbox"/>	
<input type="checkbox"/>	[11]	<input type="checkbox"/>		<input type="checkbox"/>	
<input type="checkbox"/>	[12]	<input type="checkbox"/>		<input type="checkbox"/>	
<input type="checkbox"/>	[BYP]	<input type="checkbox"/>		<input type="checkbox"/>	N/A
<input type="checkbox"/>	[MEM]	<input type="checkbox"/>		<input type="checkbox"/>	enabled
<input type="checkbox"/>	[TRBL]	<input type="checkbox"/>		<input type="checkbox"/>	enabled

TELEPHONE LINE MONITOR

Address 086, Key [2nd] [1]

KEY		
[2ND]	[1]	
OFF	OFF	TLM disabled
OFF	ON	TLM generates trouble only
ON	OFF	generates an alarm if armed
ON	ON	silent alarm becomes audible

(address 086, key [9] has to be OFF)

REPORTING OPTIONS

Address 086, Key [11] [12]

KEY	TYPE	DIALING SEQUENCE (tel. No.)
[11]	[12]	
OFF	OFF	Reporting disabled
OFF	ON	Regular reporting - 1,2,*,2,1,2,1,2, fail to comm.
ON	OFF	Split reporting: Alarms* - 1,1,1,1,1,1,1,1, fail to comm.
		System report - 2,2,2,2,2,2,2,2, fail to comm.
ON	ON	Double reporting - 1,1,*,1,1,1,1,1, fail to comm., 2,2,2,2,2,2,2,2, fail to comm.

* On alarm, all reports are made to Tel. #1 until system is disarmed. (Once disarmed, system reports are made to tel. #2)

TAMPER / WIRE FAULT DEFINITIONS

Address 088, Key [10] [11]

	KEY		
	[10]	[11]	SYSTEM DISARMED*
SYSTEM ARMED			
Alarm as per individual zone definitions	OFF	OFF	Tamper supervision disabled
Always generate trouble and alarm, audible or silent as per individual zone definitions	OFF	ON	No alarm, trouble code reported
	ON	OFF	Silent alarm, Trouble and alarm codes reported
	ON	ON	Audible alarm, Trouble and alarm codes reported**

* Exception: for 24 hour zones the tamper definition will follow the audible/silent alarm definition of the 24 hour zone.
** Silent zones will generate a silent alarm.

KEY		OFF	/	ON	
<input type="checkbox"/>	[2ND]	<input type="checkbox"/>		<input type="checkbox"/>	enabled
<input type="checkbox"/>	[1]	<input type="checkbox"/>		<input type="checkbox"/>	enabled
<input type="checkbox"/>	[2]	<input type="checkbox"/>		<input type="checkbox"/>	enabled
<input type="checkbox"/>	[3]	<input type="checkbox"/>		<input type="checkbox"/>	enabled
<input type="checkbox"/>	[4]	<input type="checkbox"/>		<input type="checkbox"/>	audible
<input type="checkbox"/>	[5]	<input type="checkbox"/>		<input type="checkbox"/>	audible
<input type="checkbox"/>	[6]	<input type="checkbox"/>		<input type="checkbox"/>	fire
<input type="checkbox"/>	[7]	<input type="checkbox"/>		<input type="checkbox"/>	enabled
<input type="checkbox"/>	[8]	<input type="checkbox"/>		<input type="checkbox"/>	enabled
<input type="checkbox"/>	[9]	<input type="checkbox"/>		<input type="checkbox"/>	4 digit
<input type="checkbox"/>	[10]	<input type="checkbox"/>		<input type="checkbox"/>	enabled
<input type="checkbox"/>	[11]	<input type="checkbox"/>		<input type="checkbox"/>	enabled
<input type="checkbox"/>	[12]	<input type="checkbox"/>		<input type="checkbox"/>	enabled on zone closure
<input type="checkbox"/>	[BYP]	<input type="checkbox"/>		<input type="checkbox"/>	no EOL
<input type="checkbox"/>	[MEM]	<input type="checkbox"/>		<input type="checkbox"/>	only after alarm
<input type="checkbox"/>	[TRBL]	<input type="checkbox"/>		<input type="checkbox"/>	

KEY		OFF	/	ON	
<input type="checkbox"/>	[2ND]	<input type="checkbox"/>		<input type="checkbox"/>	enabled
<input type="checkbox"/>	[1]	<input type="checkbox"/>		<input type="checkbox"/>	disabled (in case of fire zone 3 only)
<input type="checkbox"/>	[2]	<input type="checkbox"/>		<input type="checkbox"/>	stay / System A
<input type="checkbox"/>	[3]	<input type="checkbox"/>		<input type="checkbox"/>	N/A
<input type="checkbox"/>	[4]	<input type="checkbox"/>		<input type="checkbox"/>	N/A
<input type="checkbox"/>	[5]	<input type="checkbox"/>		<input type="checkbox"/>	N/A
<input type="checkbox"/>	[6]	<input type="checkbox"/>		<input type="checkbox"/>	tamper follows zone bypass definition
<input type="checkbox"/>	[7]	<input type="checkbox"/>		<input type="checkbox"/>	N/A
<input type="checkbox"/>	[8]	<input type="checkbox"/>		<input type="checkbox"/>	enabled
<input type="checkbox"/>	[9]	<input type="checkbox"/>		<input type="checkbox"/>	enabled
<input type="checkbox"/>	[10]	<input type="checkbox"/>		<input type="checkbox"/>	enabled
<input type="checkbox"/>	[11]	<input type="checkbox"/>		<input type="checkbox"/>	enabled
<input type="checkbox"/>	[12]	<input type="checkbox"/>		<input type="checkbox"/>	enabled
<input type="checkbox"/>	[BYP]	<input type="checkbox"/>		<input type="checkbox"/>	N/A
<input type="checkbox"/>	[MEM]	<input type="checkbox"/>		<input type="checkbox"/>	N/A
<input type="checkbox"/>	[TRBL]	<input type="checkbox"/>		<input type="checkbox"/>	N/A

ZONE DEFINITION: (reset = OFF)										
KEY SELECT:	[1]	[2]	[3]	[4]	[5]	[6]	[7]	[8]	[9]	[10]
Intellizone = ON 092	<input type="checkbox"/>	<input type="checkbox"/>	<input type="checkbox"/>	<input type="checkbox"/>	<input type="checkbox"/>	<input type="checkbox"/>	<input type="checkbox"/>	<input type="checkbox"/>	<input type="checkbox"/>	<input type="checkbox"/>
Silent = ON 096	<input type="checkbox"/>	<input type="checkbox"/>	<input type="checkbox"/>	<input type="checkbox"/>	<input type="checkbox"/>	<input type="checkbox"/>	<input type="checkbox"/>	<input type="checkbox"/>	<input type="checkbox"/>	<input type="checkbox"/>
24HR/Fire = ON 100	<input type="checkbox"/>	<input type="checkbox"/>	<input type="checkbox"/>	<input type="checkbox"/>	<input type="checkbox"/>	<input type="checkbox"/>	<input type="checkbox"/>	<input type="checkbox"/>	<input type="checkbox"/>	<input type="checkbox"/>
When zone 3 is defined "24 Hour" it becomes a fire zone										
Instant = ON 104	<input type="checkbox"/>	<input type="checkbox"/>	<input type="checkbox"/>	<input type="checkbox"/>	<input type="checkbox"/>	<input type="checkbox"/>	<input type="checkbox"/>	<input type="checkbox"/>	<input type="checkbox"/>	<input type="checkbox"/>
Follow = ON 108	<input type="checkbox"/>	<input type="checkbox"/>	<input type="checkbox"/>	<input type="checkbox"/>	<input type="checkbox"/>	<input type="checkbox"/>	<input type="checkbox"/>	<input type="checkbox"/>	<input type="checkbox"/>	<input type="checkbox"/>
Delay 2 = ON 112	<input type="checkbox"/>	<input type="checkbox"/>	<input type="checkbox"/>	<input type="checkbox"/>	<input type="checkbox"/>	<input type="checkbox"/>	<input type="checkbox"/>	<input type="checkbox"/>	<input type="checkbox"/>	<input type="checkbox"/>
System A/ STAY										
If ON, zone is armed on stay or "system A" arming 116	<input type="checkbox"/>	<input type="checkbox"/>	<input type="checkbox"/>	<input type="checkbox"/>	<input type="checkbox"/>	<input type="checkbox"/>	<input type="checkbox"/>	<input type="checkbox"/>	<input type="checkbox"/>	<input type="checkbox"/>
System B										
If ON, zone is armed in "system B" arming 120	<input type="checkbox"/>	<input type="checkbox"/>	<input type="checkbox"/>	<input type="checkbox"/>	<input type="checkbox"/>	<input type="checkbox"/>	<input type="checkbox"/>	<input type="checkbox"/>	<input type="checkbox"/>	<input type="checkbox"/>
Bypass enable = ON 124	<input type="checkbox"/>	<input type="checkbox"/>	<input type="checkbox"/>	<input type="checkbox"/>	<input type="checkbox"/>	<input type="checkbox"/>	<input type="checkbox"/>	<input type="checkbox"/>	<input type="checkbox"/>	<input type="checkbox"/>

Zones that are not selected at addresses 100 to 112 become "Delay 1" zones.

Note: Do not use the Intellizone feature and an entry delay for the same zone, otherwise an alarm may occur as a user tries to disarm the system.

KEY ACCESS PROGRAMMING

Programs features quickly, without entering addresses or section numbers.

To activate "key access programming", press [ENTER], followed by installer, master or user code 1. (Code required depends on the feature you wish to access - see below.) Press the key corresponding to the desired feature.

Press [ENTER] or [CLEAR] to exit.

key

- [8] Installer test mode** *(installer code only)*
In installer test mode, a confirmation beep (intermittent) indicates test is "on", a "rejection" beep (long) indicates test is "off". The bell will squawk during walk testing to indicate opened, functional zones.
- [9] "Auto arming" time program** *(all 3 codes)*
Key [9] flashes. Enter two digits (00 to 23) for hours + 2 digits (00 to 59) for minutes.
- [MEM] "Panel time" and clear "trouble 8"** *(all 3 codes)*
Key [MEM] flashes. Enter two digits (00 to 23) for hours + 2 digits (00 to 59) for minutes.
- [BYP] Test report** *(all 3 codes)*
Reporting is enabled at address **086**, keys [11], [12]. A value must be entered at address **512**, and both telephone and account numbers must be programmed.
- [TRBL] Call Espload via telephone** *(all 3 codes)*
Panel identifier and PC password (addresses **004-007**) and computer telephone number (addresses **008-015**) must be programmed.
- [AWAY] Answer Espload** *(all 3 codes)*
This feature is available when using the ADP-1 adapter. In Espload, "blind dial" must be activated in "modem setup" section, and panel phone number programmed (works also without ADP-1).
- [STAY] Cancel communication attempts** *(master code and user 1 can only stop calls to Espload)*
Until next reportable event *(installer code - all communications)*

When communicating with Espload, it is impossible to enter programming mode.

CONNECTION DIAGRAMS

The system hardware will recognize the following zone conditions:

SINGLE ZONE CONNECTIONS

N.C. Contacts, Without EOL Resistor

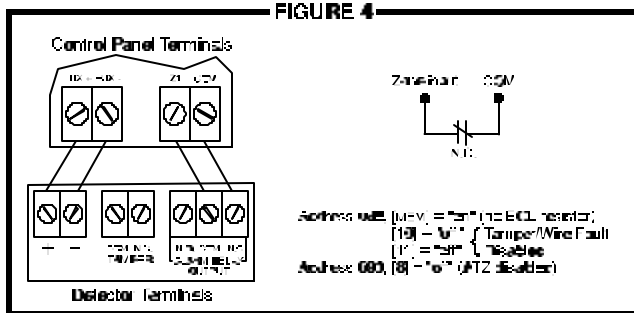

N.C. Contacts, With EOL Resistor (UL/ULC)

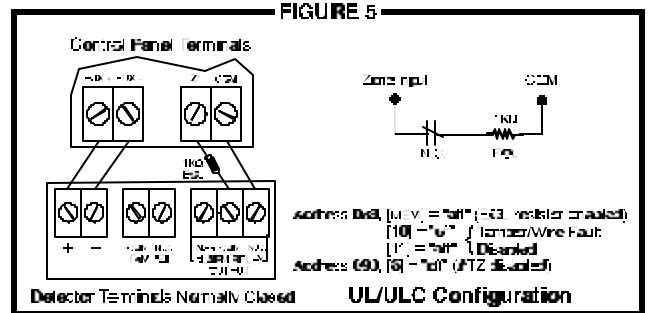

N.O. Contacts, With EOL Resistor (UL/ULC)

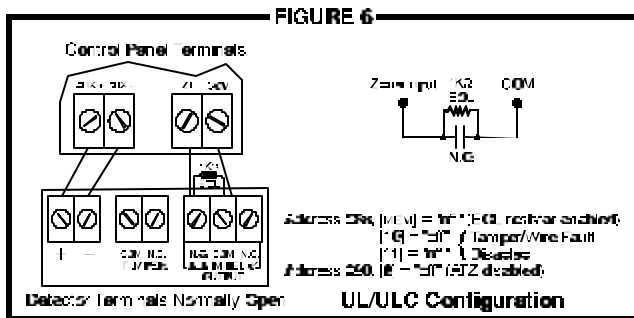

N.C. Contacts, Without EOL Resistor, With Tamper Recognition

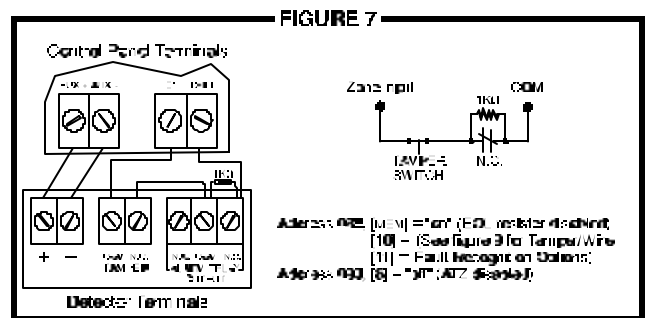

N.C. Contacts, With EOL Resistor, With Tamper and Wire Fault Recognition (UL/ULC)

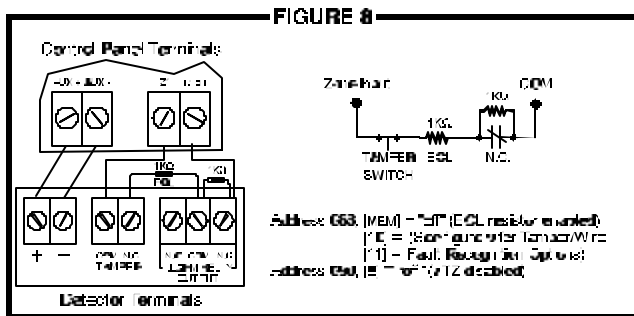

FIGURE 9

TAMPER / WIRE FAULT DEFINITIONS

Address 002, Key [10] [11]

SYSTEM ARMED	KEY [10] [11]	SYSTEM DISARMED*
Alarm as per individual zone definitions	-OFF OFF	- Tamper supervision disabled
Always generate trouble and alarm, audible or silent as per individual zone definitions	-OFF ON	- No alarm, trouble codes reported
	ON OFF	- Silent alarm, Trouble and alarm codes reported
	ON ON	- Audible alarm, Trouble and alarm codes reported**

* Exception: for 24 hour zones the tamper definition will follow the audible/silent alarm definition of the 24 hour zone.
 ** Silent zones will generate a silent alarm.

CONNECTION DIAGRAMS (continued)

ADVANCED TECHNOLOGY ZONE CONNECTIONS (2 zones / input)

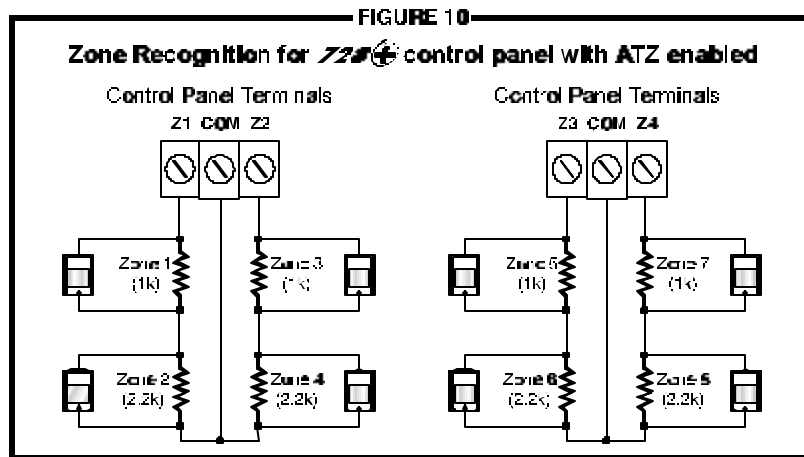

N.C. Contacts, Without EOL Resistor

N.C. Contacts, Without EOL Resistor, With Tamper Recognition

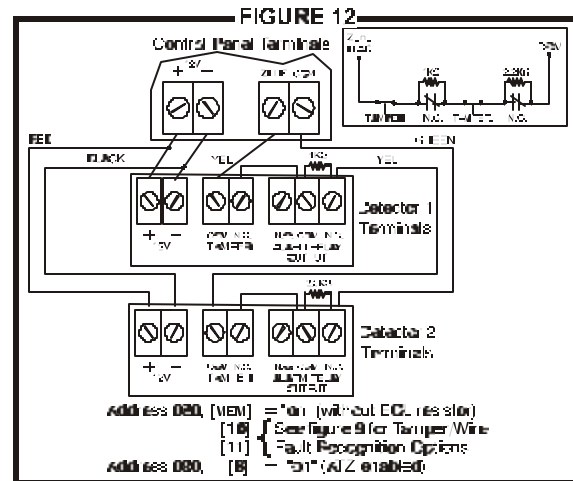
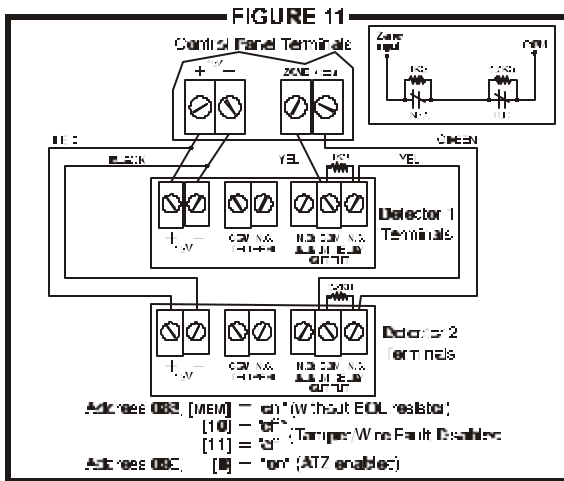

N.C. Contacts, With EOL Resistor, With Tamper & Wire Fault Recognition (UL/ULC)

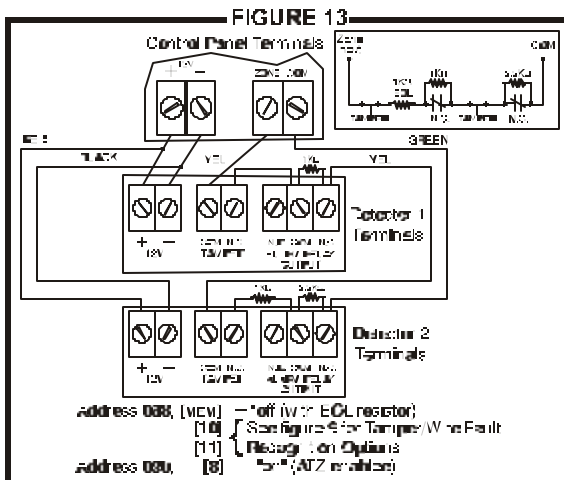

KEYPAD ZONE CONNECTION DIAGRAMS

Note: Keypad zones always use (1K OHM) EOL resistor.

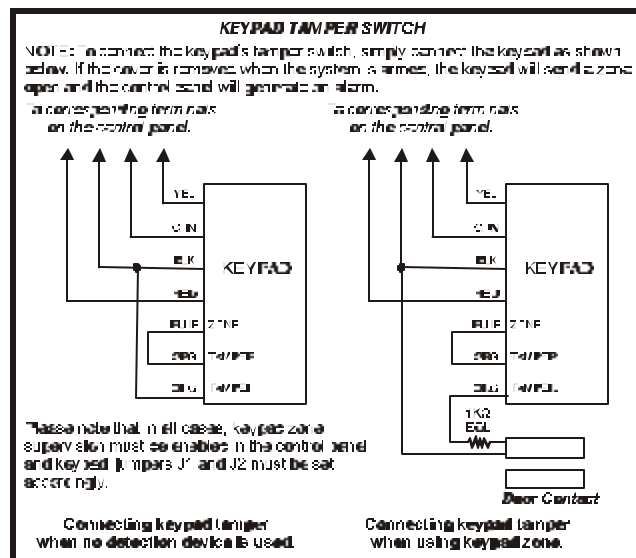
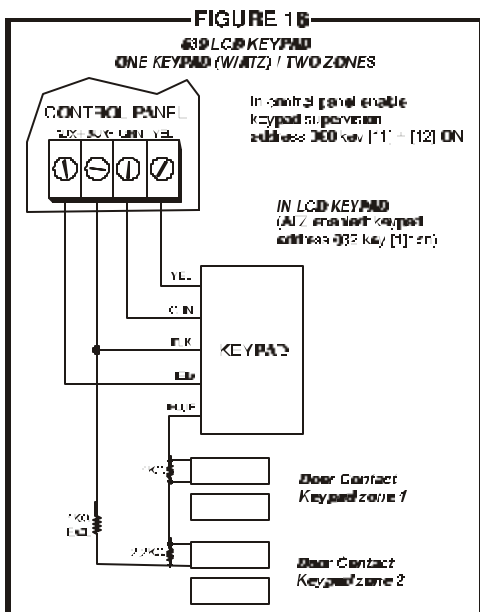
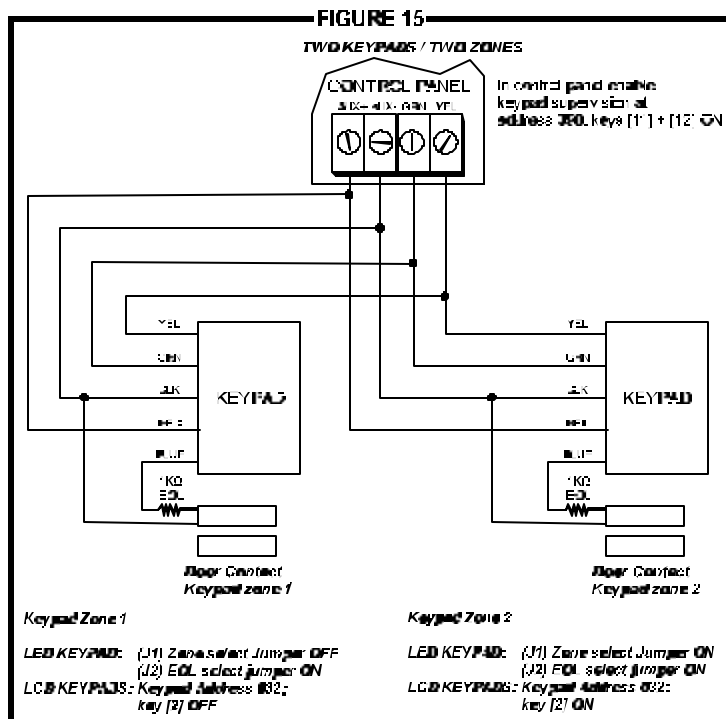
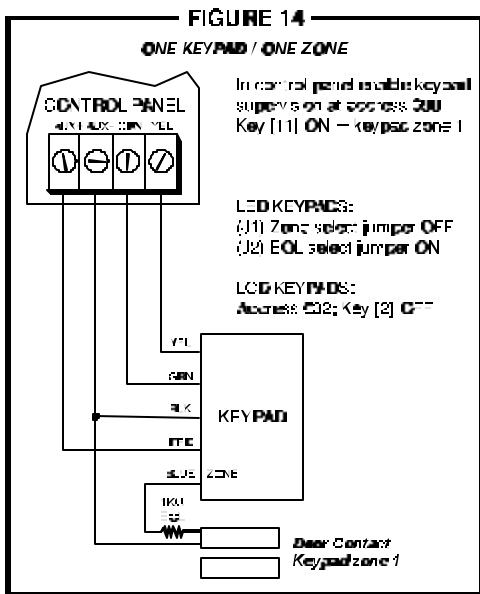

ESPRIT 728+ WIRING DIAGRAM

Charging and battery test LED (every 60 seconds)

Service Keypad



Four pin connector can be used for quick installation of an Esprit keypad.

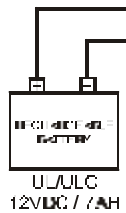

Caution: Disconnect battery before replacing fuse.

UL: K12 model T16 V4C
ULC: Frost model FTC 16J7

Warning: Improper connection may result in damage to the system.



BELL OUTPUT will shut down if current exceeds 3A.



PARADOX SECURITY SYSTEMS

728+

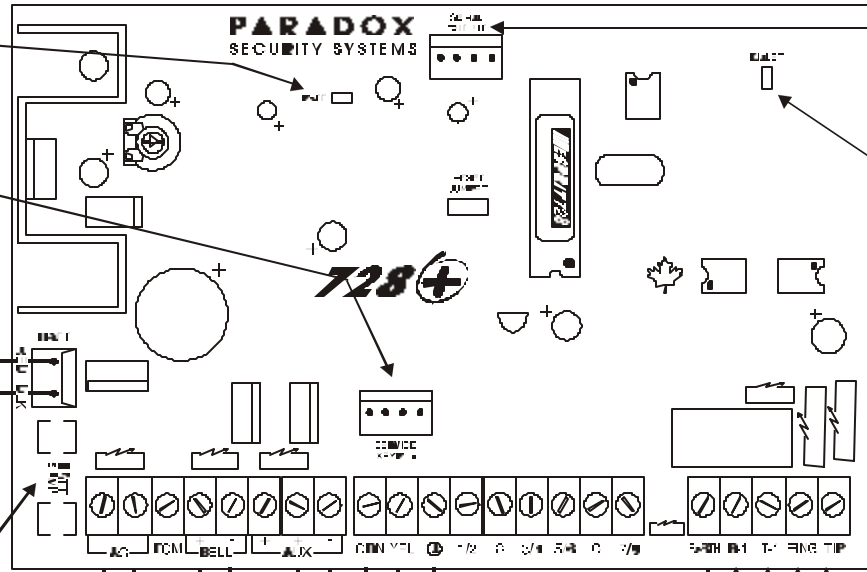

For use with 708, Esprit, and SRI-18 PGM expander. Note: To use you must disable PGM. To do so program [2ND] [2N3] in sections 039, 040 + 042.

TLM LED: Short flash = OK
Long flash = Fault
OFF = Disabled
Constant = On Line

Warning: Disconnect telephone line before servicing.



To provide maximum lightning protection we strongly recommend having separate earth connections for the dialer and zone ground terminals.

FIRE ALARM ZONE CONNECTIONS

Without ATZ Address 090; key [1] on
Address 100; key [3] on.
To set zone 3 as a fire zone.

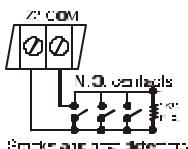

With ATZ enabled Address 090; key [1] off
Address 100; key [3] on.

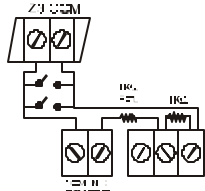

FIRE RESET

To program PGM to connect 4 zone smoke detectors read when [alarm] and [normal] are present simultaneously:

- Address 008 - [any] [0] [5] [9]
- Address 002 - [2] [0] [1] [0]
- Address 002 - [2] [0] [1] [0]
- Address 008 - [0] [0] [0] [0]

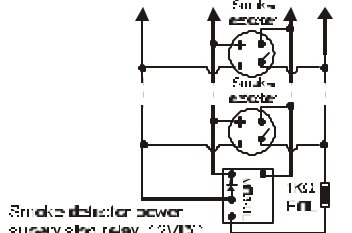
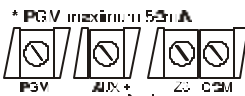

Smoke detector power supervision relay, 12VDC
Smoke detector must be 4 wire latching - UL: Falcon models S454, ULC BTRC 2412.
Power supervision relay model MR3-UL.

AUX POWER 400mA max. 250mA max. for 24 hr. standby. To connect additional wiring to auxiliary power, use the red (+) and black (-) keypad connectors. Aux power will shut down if current exceeds 1A.

KEYPADS

- LED Keypads 616, 626, & 633
- LCD Keypads 639 and 640
- PS1 Bedside Remote

The maximum number of keypads per installation is dependent on the auxiliary output, which is not to exceed 400mA. Please refer to the current consumption table in section 2.3.3 of the instruction manual. For information on connecting keypad zones, refer to page 13 of the programming guide.

GROUND START CIRCUIT

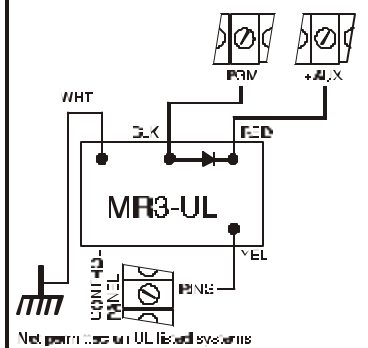

PGM OUTPUT RELAY

