

TUSB3200 Data Manual

USB Streaming Controller (STC)

Literature Number: SLAS240
October 1999



IMPORTANT NOTICE

Texas Instruments and its subsidiaries (TI) reserve the right to make changes to their products or to discontinue any product or service without notice, and advise customers to obtain the latest version of relevant information to verify, before placing orders, that information being relied on is current and complete. All products are sold subject to the terms and conditions of sale supplied at the time of order acknowledgement, including those pertaining to warranty, patent infringement, and limitation of liability.

TI warrants performance of its semiconductor products to the specifications applicable at the time of sale in accordance with TI's standard warranty. Testing and other quality control techniques are utilized to the extent TI deems necessary to support this warranty. Specific testing of all parameters of each device is not necessarily performed, except those mandated by government requirements.

CERTAIN APPLICATIONS USING SEMICONDUCTOR PRODUCTS MAY INVOLVE POTENTIAL RISKS OF DEATH, PERSONAL INJURY, OR SEVERE PROPERTY OR ENVIRONMENTAL DAMAGE ("CRITICAL APPLICATIONS"). TI SEMICONDUCTOR PRODUCTS ARE NOT DESIGNED, AUTHORIZED, OR WARRANTED TO BE SUITABLE FOR USE IN LIFE-SUPPORT DEVICES OR SYSTEMS OR OTHER CRITICAL APPLICATIONS. INCLUSION OF TI PRODUCTS IN SUCH APPLICATIONS IS UNDERSTOOD TO BE FULLY AT THE CUSTOMER'S RISK.

In order to minimize risks associated with the customer's applications, adequate design and operating safeguards must be provided by the customer to minimize inherent or procedural hazards.

TI assumes no liability for applications assistance or customer product design. TI does not warrant or represent that any license, either express or implied, is granted under any patent right, copyright, mask work right, or other intellectual property right of TI covering or relating to any combination, machine, or process in which such semiconductor products or services might be or are used. TI's publication of information regarding any third party's products or services does not constitute TI's approval, warranty or endorsement thereof.

Contents

| <i>Section</i> | <i>Title</i> | <i>Page</i> |
|----------------|--|-------------|
| 1 | Introduction | 1-1 |
| 1.1 | Features | 1-1 |
| 1.2 | Functional Block Diagram | 1-3 |
| 1.3 | Terminal Assignments – Normal Mode | 1-4 |
| 1.4 | Terminal Assignments – External MCU Mode | 1-4 |
| 1.5 | Ordering Information | 1-5 |
| 1.6 | Terminal Functions – Normal Mode | 1-5 |
| 1.7 | Terminal Functions – External MCU Mode | 1-7 |
| 1.8 | Device Operation Modes | 1-9 |
| 1.9 | Terminal Assignments for CODEC Port Interface Modes | 1-9 |
| 2 | Description | 2-1 |
| 2.1 | Architectural Overview | 2-1 |
| 2.1.1 | Oscillator and PLL | 2-1 |
| 2.1.2 | Clock Generator and Sequencer Logic | 2-1 |
| 2.1.3 | Adaptive Clock Generator (ACG) | 2-1 |
| 2.1.4 | USB Transceiver | 2-1 |
| 2.1.5 | USB Serial Interface Engine (SIE) | 2-1 |
| 2.1.6 | USB Buffer Manager (UBM) | 2-2 |
| 2.1.7 | USB Frame Timer | 2-2 |
| 2.1.8 | USB Suspend and Resume Logic | 2-2 |
| 2.1.9 | MCU Core | 2-2 |
| 2.1.10 | MCU Memory | 2-2 |
| 2.1.11 | USB Endpoint Configuration Blocks and Endpoint Buffer Space | 2-2 |
| 2.1.12 | DMA Controller | 2-2 |
| 2.1.13 | CODEC Port Interface | 2-3 |
| 2.1.14 | I ² C Interface | 2-3 |
| 2.1.15 | Pulse Width Modulation (PWM) Output | 2-3 |
| 2.1.16 | General-Purpose IO Ports (GPIO) | 2-3 |
| 2.1.17 | Interrupt Logic | 2-3 |
| 2.1.18 | Reset Logic | 2-3 |
| 2.2 | Device Operation | 2-3 |
| 2.2.1 | Clock Generation | 2-3 |
| 2.2.2 | Device Initialization | 2-4 |
| 2.2.3 | USB Enumeration | 2-5 |
| 2.2.4 | USB Reset | 2-5 |
| 2.2.5 | USB Suspend and Resume Modes | 2-6 |

| | | |
|-----------------|--|------------|
| 2.2.6 | Power Supply Sequencing | 2-6 |
| 2.2.7 | USB Transfers | 2-7 |
| 2.2.8 | Adaptive Clock Generator (ACG) | 2-14 |
| 2.2.9 | Microcontroller Unit | 2-16 |
| 2.2.10 | External MCU Mode Operation | 2-16 |
| 2.2.11 | Interrupt Logic | 2-16 |
| 2.2.12 | DMA Controller | 2-17 |
| 2.2.13 | CODEC Port Interface | 2-17 |
| 2.2.14 | I ² C Interface | 2-22 |
| 3 | Electrical Specifications | 3-1 |
| 3.1 | Absolute Maximum Ratings Over Operating Temperature Ranges . | 3-1 |
| 3.2 | Recommended Operating Conditions | 3-1 |
| 3.3 | Electrical Characteristics Over Recommended Operating Conditions | 3-2 |
| 3.4 | Timing Characteristics | 3-3 |
| 3.4.1 | Clock and Control Signals Over Recommended Operating Conditions | 3-3 |
| 3.4.2 | USB Transceiver Signals Over Recommended Operating Conditions | 3-3 |
| 3.4.3 | CODEC Port Interface Signals (AC '97 Modes) | 3-4 |
| 3.4.4 | CODEC Port Interface Signals (I ² S Modes) Over Recommended Operating Conditions | 3-5 |
| 3.4.5 | CODEC Port Interface Signals (General-Purpose Mode) Over Recommended Operating Conditions | 3-5 |
| 3.4.6 | I ² C Interface Signals Over Recommended Operating Conditions | 3-6 |
| 4 | Application Information | 4-1 |
| Appendix | | |
| A | MCU Memory and Memory Mapped Registers | A-1 |
| A.1 | MCU Memory Space | A-1 |
| A.2 | Internal Data Memory | A-2 |
| A.3 | External MCU Mode Memory Space | A-3 |
| A.4 | USB Endpoint Configuration Blocks and Data Buffers Space | A-4 |
| A.5 | Memory-Mapped Registers | A-15 |
| B | Mechanical Data | B-1 |

List of Illustrations

| <i>Figure</i> | <i>Title</i> | <i>Page</i> |
|---------------|--|-------------|
| 2-1 | Adaptive Clock Generator | 2-15 |
| 2-2 | Connection of the TUSB3200 to an AC '97 CODEC | 2-19 |
| 2-3 | Connection of the TUSB3200 to Multiple AC '97 CODECs | 2-20 |
| 2-4 | Single Byte Write Transfer | 2-23 |
| 2-5 | Multiple Byte Write Transfer | 2-23 |
| 2-6 | Single Byte Read Transfer | 2-23 |
| 2-7 | Multiple Byte Read Transfer | 2-24 |
| 3-1 | External Interrupt Timing Waveform | 3-3 |
| 3-2 | USB Differential Driver Timing Waveform | 3-3 |
| 3-3 | BIT_CLK and SYNC Timing Waveforms | 3-4 |
| 3-4 | SYNC, SD_IN, and SD_OUT Timing Waveforms | 3-4 |
| 3-5 | I ² S Mode Timing Waveforms | 3-5 |
| 3-6 | General-Purpose Mode Timing Waveforms | 3-5 |
| 3-7 | SCL and SDA Timing Waveforms | 3-6 |
| 3-8 | Start and Stop Conditions Timing Waveforms | 3-6 |
| 3-9 | Acknowledge Timing Waveform | 3-6 |
| 4-1 | Typical TUSB3200 Device Connections | 4-1 |

List of Tables

| <i>Table</i> | <i>Title</i> | <i>Page</i> |
|--------------|--|-------------|
| 2-1 | EEPROM Header | 2-4 |
| 2-2 | USB Device Information | 2-5 |
| 2-3 | Terminal Assignments for CODEC Port Interface AC '97 10 Mode | 2-18 |
| 2-4 | Terminal Assignments for CODEC Port Interface AC '97 20 Mode | 2-19 |
| 2-5 | Terminal Assignments for CODEC Port Interface I ² S Modes | 2-20 |
| 2-6 | SLOT Assignments for CODEC Port Interface I ² S Mode (Output) | 2-21 |
| 2-7 | SLOT Assignments for CODEC Port Interface I ² S Mode (Input) | 2-21 |
| 2-8 | Terminal Assignments for CODEC Port Interface General-Purpose Mode | 2-22 |

1 Introduction

The TUSB3200 integrated circuit (IC) is a universal serial bus (USB) peripheral interface device designed specifically for applications that require isochronous data streaming. Applications include digital speakers, which require the streaming of digital audio data between the host PC and the speaker system via the USB connection. The USB3200 device is fully compatible with the USB Specification Version 1.1 and the USB Audio Class Specification.

The TUSB3200 uses a standard 8052 microcontroller unit (MCU) core with on-chip memory. The MCU memory includes 4K bytes of program memory ROM that contains a boot loader program. At initialization, the boot loader program downloads the application program code to an 8K RAM from a nonvolatile memory on the printed-circuit board (PCB). The MCU handles all USB control, interrupt and bulk endpoint transactions. In addition, the MCU can handle USB isochronous endpoint transactions.

The USB interface includes an integrated transceiver that supports 12 Mb/s (full speed) data transfers. In addition to the USB control endpoint, support is provided for up to seven in endpoints and seven out endpoints. The USB endpoints are fully configurable by the MCU application code using a set of endpoint configuration blocks that reside in on-chip RAM. All USB data transfer types are supported.

The TUSB3200 device also includes a CODEC port interface (C-Port) that can be configured to support several industry standard serial interface protocols. These protocols include the audio CODEC (AC) '97 Revision 1.X, the audio CODEC (AC) '97 Revision 2.X and several Inter-IC sound (I²S) modes.

A direct memory access (DMA) controller with four channels is provided for streaming the USB isochronous data packets to/from the CODEC port interface. Each DMA channel can support one USB isochronous endpoint.

An on-chip phase lock loop (PLL) and adaptive clock generator (ACG) provide support for the USB synchronization modes, which include asynchronous, synchronous and adaptive.

Other on-chip MCU peripherals include an Inter-IC control (I²C) serial interface, two general-purpose input/output (GPIO) ports, and a pulse width modulation (PWM) output.

The TUSB3200 device is implemented in a 3.3-V 0.25 μ m CMOS technology. In addition, the use of 5-V compatible input/output buffers for the CODEC port interface allows the TUSB3200 device to be connected to either 3.3-V or 5-V CODEC devices.

1.1 Features

- **Universal Serial Bus (USB)**
 - USB Specification version 1.1 compatible
 - USB Audio Class Specification 1.0 compatible
 - Integrated USB transceiver
 - Supports 12 Mb/s data rate (full speed)
 - Supports suspend/resume and remote wake-up
 - Supports control, interrupt, bulk and isochronous data transfer types
 - Supports up to a total of 7 in endpoints and 7 out endpoints in addition to the control endpoint
 - Data transfer type, data buffer size, single or double buffering is programmable for each Endpoint
 - On-Chip adaptive clock generator (ACG) supports asynchronous, synchronous and adaptive synchronization modes for isochronous endpoints
 - To support synchronization for streaming USB audio data, the ACG can be used to generate the master clock for the CODEC

- **Micro-Controller Unit (MCU)**
 - Standard 8052 8-bit core
 - 4K Bytes of program memory ROM that contains a boot loader program that loads the application firmware from external EEPROM
 - 8K Bytes of program memory RAM which is loaded by the boot loader program
 - 256 Bytes of internal data memory RAM
 - Two GPIO ports
 - MCU handles all USB control, interrupt and bulk endpoint transfers
- **DMA Controller**
 - Four DMA channels to support streaming USB audio data to/from the CODEC Port Interface
 - Each channel can support a single USB isochronous endpoint
 - For I²S modes, either a single or multiple USB isochronous endpoints can be used to support multiple DACs/ADCs
- **CODEC Port Interface**
 - Configurable to support AC'97 1.X, AC'97 2.X or I²S serial interface formats
 - I²S modes can support a combination of up to 4 DACs and/or 3 ADCs
 - Can be configured as a general-purpose serial interface
- **I²C Interface**
 - Master only interface
 - Does not support a multimaster bus environment
 - Programmable to 100 kbit/s or 400 kbit/s data transfer speeds
- **Pulse Width Modulation (PWM) Output**
 - Programmable frequency range from 732.4 Hz to 93.75 kHz
 - Programmable duty cycle
- **General Characteristics**
 - Available in a 52-Pin TQFP Package
 - On-chip phase-locked loop (PLL) with internal oscillator is used to generate internal clocks from a 6 MHz crystal input
 - 3.3-V core and 5-V compatible input/output buffers used for CODEC port interface
 - Reset output available which is asserted for both system and USB reset
 - External MCU mode supports application firmware development

1.2 Functional Block Diagram

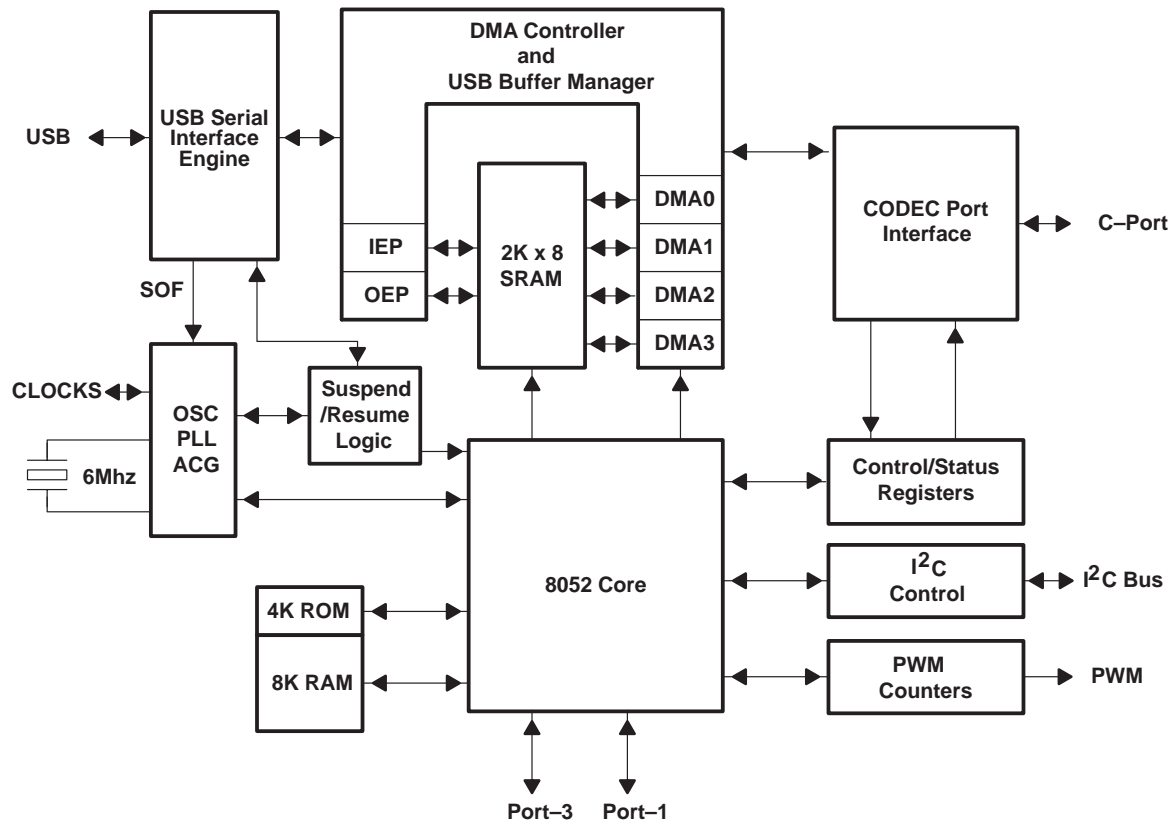

1.3 Terminal Assignments – Normal Mode

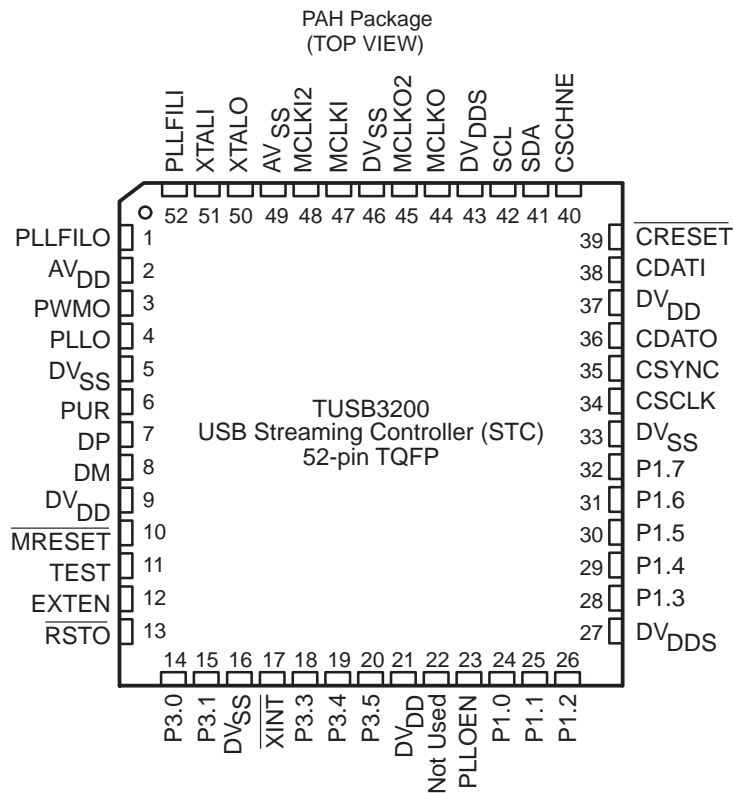

1.4 Terminal Assignments – External MCU Mode

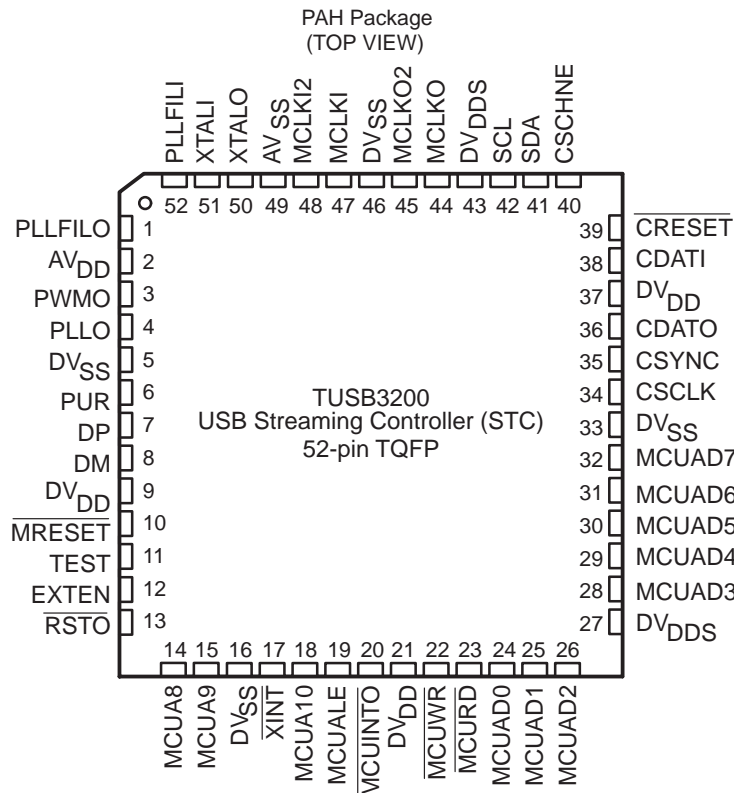

1.5 Ordering Information

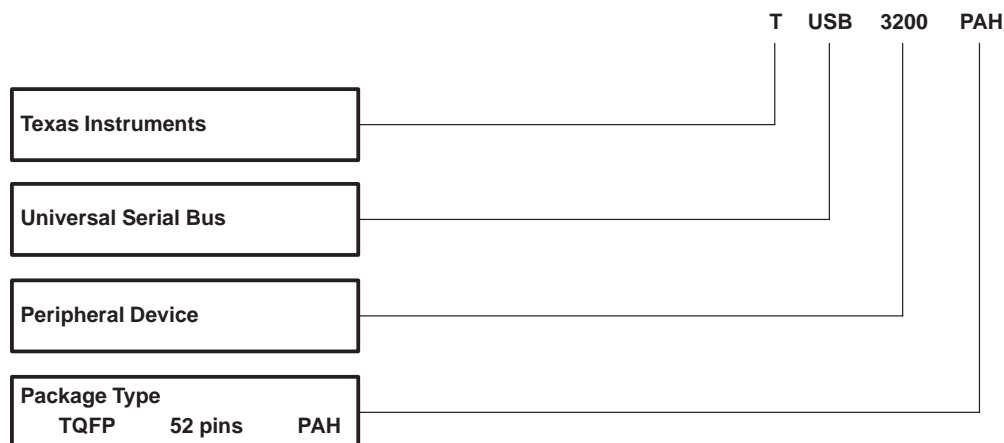

1.6 Terminal Functions – Normal Mode

| TERMINAL NAME | NO. | I/O | DESCRIPTION |
|-------------------|---------------|-----|---|
| AV _{DD} | 2 | | 3.3-V Analog supply voltage |
| AV _{SS} | 49 | | Analog ground |
| CSCLK | 34 | I/O | CODEC port interface serial clock: CSCLK is the serial clock for the CODEC port interface used to clock the CSYNC, CDATO, CDATI, CRESET AND CSCHNE signals. This signal uses a 5-V compatible TTL/LVCMOS input/output buffer. |
| CSYNC | 35 | I/O | CODEC port interface frame sync: CSYNC is the frame synchronization signal for the CODEC port interface. This signal uses a 5-V compatible TTL/LVCMOS input/output buffer. |
| CDATO | 36 | I/O | CODEC port interface serial data output: See section 1.9 for details. This signal uses a 5-V compatible TTL/LVCMOS input/output buffer. |
| CDATI | 38 | I/O | CODEC port interface serial data input: See section 1.9 for details. This signal uses a 5-V compatible TTL/LVCMOS input/output buffer. |
| CRESET | 39 | I/O | CODEC port interface reset output: See section 1.9 for details. This signal uses a 5-V compatible TTL/LVCMOS input/output buffer. |
| CSCHNE | 40 | I/O | CODEC port interface secondary channel enable: See section 1.9 for details. This signal uses a 5-V compatible TTL/LVCMOS input/output buffer. |
| DP | 7 | I/O | USB differential pair data signal plus: DP is the positive signal of the bidirectional USB differential pair used to connect the TUSB3200 device to the universal serial bus. |
| DM | 8 | I/O | USB differential pair data signal minus: DM is the negative signal of the bidirectional USB differential pair used to connect the TUSB3200 device to the universal serial bus. |
| DV _{DD} | 9, 21, 37 | | 3.3-V Digital supply voltage |
| DV _{DDS} | 27, 43 | | 5-V Digital supply voltage |
| DV _{SS} | 5, 16, 33, 46 | | Digital ground |
| EXTEN | 12 | I | External MCU mode enable: Input used to enable the device for the external MCU mode. This signal luses a 3.3-V TTL/LVCMOS input buffer. |
| MCLKI | 47 | I | Master clock input: An input that can be used as the master clock for the CODEC port interface or the source for MCLKO2. This signal uses a 5-V to 3.3-V level shifting input buffer. |
| MCLKI2 | 48 | I | Master clock input 2: An input that can be used as the master clock for the CODEC port interface or the source for MCLKO2. This signal uses a 5-V to 3.3-V level shifting input buffer. |
| MCLKO | 44 | O | Master clock output: The output of the ACG that can be used as the master clock for the CODEC port interface and the CODEC. This signal uses a 3.3-V TTL/LVCMOS output buffer. |

1.6 Terminal Functions – Normal Mode (Continued)

| TERMINAL NAME | NO. | I/O | DESCRIPTION |
|----------------------------|-----|-----|---|
| MCLKO2 | 45 | O | Master clock output 2: An output that can be used as the master clock for the CODEC port interface and the CODEC. This clock signal can also be used as a miscellaneous clock. This signal uses a 3.3-V TTL/LVCMOS output buffer. |
| $\overline{\text{MRESET}}$ | 10 | I | Master reset: An active low asynchronous reset for the device that resets all logic to the default state. This signal uses a 3.3-V TTL/LVCMOS input buffer. |
| Not Used | 22 | I | This pin is not used in the normal mode. This signal should be tied to digital ground for normal operation. |
| P1.0 | 24 | I/O | General-purpose I/O port 1 bit 0: A bidirectional I/O port. This signal uses a 5-V compatible TTL/LVCMOS input/output buffer with an internal 100 μA active pullup. |
| P1.1 | 25 | I/O | General-purpose I/O port 1 bit 1: A bidirectional I/O port. This signal uses a 5-V compatible TTL/LVCMOS input/output buffer with an internal 100 μA active pullup. |
| P1.2 | 26 | I/O | General-purpose I/O port 1 bit 2: A bidirectional I/O port. This signal uses a 5-V compatible TTL/LVCMOS input/output buffer with an internal 100 μA active pullup. |
| P1.3 | 28 | I/O | General-purpose I/O port 1 bit 3: A bidirectional I/O port. This signal uses a 5-V compatible TTL/LVCMOS input/output buffer with an internal 100 μA active pullup. |
| P1.4 | 29 | I/O | General-purpose I/O port 1 bit 4: A bidirectional I/O port. This signal uses a 5-V compatible TTL/LVCMOS input/output buffer with an internal 100 μA active pullup. |
| P1.5 | 30 | I/O | General-purpose I/O port 1 bit 5: A bidirectional I/O port. This signal uses a 5-V compatible TTL/LVCMOS input/output buffer with an internal 100 μA active pullup. |
| P1.6 | 31 | I/O | General-purpose I/O port 1 bit 6: A bidirectional I/O port. This signal uses a 5-V compatible TTL/LVCMOS input/output buffer with an internal 100 μA active pullup. |
| P1.7 | 32 | I/O | General-purpose I/O port 1 bit 7: A bidirectional I/O port. This signal uses a 5-V compatible TTL/LVCMOS input/output buffer with an internal 100 μA active pullup. |
| P3.0 | 14 | I/O | General-purpose I/O port 3 bit 0: A bidirectional I/O port. This signal uses a 5-V compatible TTL/LVCMOS input/output buffer with an internal 100 μA active pullup. |
| P3.1 | 15 | I/O | General-purpose I/O port 3 bit 1: A bidirectional I/O port. This signal uses a 5-V compatible TTL/LVCMOS input/output buffer with an internal 100 μA active pullup. |
| P3.3 | 18 | I/O | General-purpose I/O port 3 bit 3: A bidirectional I/O port. This signal uses a 5-V compatible TTL/LVCMOS input/output buffer with an internal 100 μA active pullup. |
| P3.4 | 19 | I/O | General-purpose I/O port 3 bit 4: A bidirectional I/O port. This signal uses a 5-V compatible TTL/LVCMOS input/output buffer with an internal 100 μA active pullup. |
| P3.5 | 20 | I/O | General-purpose I/O port 3 bit 5: A bidirectional I/O port. This signal uses a 5-V compatible TTL/LVCMOS input/output buffer with an internal 100 μA active pullup. |
| PLLFILI | 52 | I | PLL loop filter input: Input to on-chip PLL from external filter components. |
| PLLFILO | 1 | O | PLL loop filter output: Output from on-chip PLL to external filter components. |
| PLLO | 4 | O | PLL output: The 48-MHz output of the PLL used for diagnostic purposes only. This signal uses a 3.3-V TTL/LVCMOS output buffer. |
| PLLOEN | 23 | I | PLL output enable: An input used to enable the PLLO output signal. This signal uses a 5-V compatible input buffer. |
| PWMO | 3 | O | PWM output: Output of the pulse width modulation circuit. This signal uses a 3.3-V to 5-V CMOS level shifting output buffer. |
| PUR | 6 | O | USB data signal plus pullup resistor connect: PUR is used to connect the pullup resistor on the DP signal to 3.3-V or a 3-state. When the DP signal is connected to 3.3-V the host PC should detect the connection of the TUSB3200 device to the universal serial bus. This signal uses a 3.3-V TTL/LVCMOS output buffer. |
| $\overline{\text{RSTO}}$ | 13 | O | Reset output: Output that is active while the master reset input or the USB reset is active. This signal uses a 3.3-V TTL/LVCMOS output buffer. |
| SCL | 42 | O | I ² C interface serial clock: SCL is the clock signal for the I ² C serial interface. This signal uses a 3.3-V to 5-V TTL level shifting open drain output buffer. |

1.6 Terminal Functions – Normal Mode (Continued)

| TERMINAL NAME | NO. | I/O | DESCRIPTION |
|--------------------------|-----|-----|--|
| SDA | 41 | I/O | I ² C interface serial data input/output: SDA is the bidirectional data signal for the I ² C serial interface. This signal uses a 3.3-V to 5-V TTL level shifting open drain output buffer and a 5-V to 3.3-V TTL level shifting input buffer. |
| TEST | 11 | I | Test mode enable: Input used to enable the device for the factory test mode. This signal uses a 3.3-V TTL/LVCMOS input buffer. |
| $\overline{\text{XINT}}$ | 17 | I | External interrupt: An active low input used by external circuitry to interrupt the on-chip 8052 MCU. This signal uses a 5-V compatible input buffer. |
| XTALI | 51 | I | Crystal input: Input to the on-chip oscillator from an external 6-MHz crystal. |
| XTALO | 50 | O | Crystal Output: Output from the on-chip oscillator to an external 6-MHz crystal. |

1.7 Terminal Functions – External MCU Mode

| TERMINAL NAME | NO. | I/O | DESCRIPTION |
|-----------------------------------|---------------|-----|--|
| AV _{DD} | 2 | | 3.3-V Analog supply voltage |
| AV _{SS} | 49 | | Analog ground |
| C _S CLK | 34 | I/O | CODEC port interface serial clock: C _S CLK is the serial clock for the CODEC port interface used to clock the C _S SYNC, C _D ATO, C _D ATI, $\overline{\text{C}}\text{RESET}$ AND C _S CHNE signals. This signal uses a 5-V compatible TTL/LVCMOS input/output buffer. |
| C _S SYNC | 35 | I/O | CODEC port interface frame sync: C _S SYNC is the frame synchronization signal for the CODEC port interface. This signal uses a 5-V compatible TTL/LVCMOS input/output buffer. |
| C _D ATO | 36 | I/O | CODEC port interface serial data output: See section 1.9 for details. This signal uses a 5-V compatible TTL/LVCMOS input/output buffer. |
| C _D ATI | 38 | I/O | CODEC port interface serial data input: See section 1.9 for details. This signal uses a 5-V compatible TTL/LVCMOS input/output buffer. |
| $\overline{\text{C}}\text{RESET}$ | 39 | I/O | CODEC port interface reset output: See section 1.9 for details. This signal uses a 5-V compatible TTL/LVCMOS input/output buffer. |
| C _S CHNE | 40 | I/O | CODEC port interface secondary channel enable: See section 1.9 for details. This signal uses a 5-V compatible TTL/LVCMOS input/output buffer. |
| DP | 7 | I/O | USB differential pair data signal plus: DP is the positive signal of the bidirectional USB differential pair used to connect the TUSB3200 device to the universal serial bus. |
| DM | 8 | I/O | USB differential pair data signal minus: DM is the negative signal of the bidirectional USB differential pair used to connect the TUSB3200 device to the universal serial bus. |
| DV _{DD} | 9, 21, 37 | | 3.3-V Digital supply voltage |
| DV _{DD} S | 27, 43 | | 5 V-Digital supply voltage |
| DV _{SS} | 5, 16, 33, 46 | | Digital ground |
| EXTEN | 12 | I | External MCU mode enable: Input used to enable the device for the external MCU mode. This signal uses a 3.3 V TTL/LVCMOS input buffer. |
| MCLKI | 47 | I | Master clock input: An input that can be used as the master clock for the CODEC port interface or the source for MCLKO2. This signal uses a 5-V to 3.3-V level shifting input buffer. |
| MCLKI2 | 48 | I | Master clock input 2: An input that can be used as the master clock for the CODEC port interface or the source for MCLKO2. This signal uses a 5-V to 3.3-V level shifting input buffer. |
| MCLKO | 44 | O | Master clock output: The output of the ACG that can be used as the master clock for the CODEC port interface and the CODEC. This signal uses a 3.3-V TTL/LVCMOS output buffer |
| MCLKO2 | 45 | O | Master clock output 2: An output that can be used as the master clock for the CODEC port interface and the CODEC. This clock signal can also be used as a miscellaneous clock. This signal uses a 3.3-V TTL/LVCMOS output buffer. |
| MCUAD0 | 24 | I/O | MCU multiplexed address/data bit 0: Multiplexed address bit 0/data bit 0 for external MCU access to the TUSB3200 external data memory space. |

1.7 Terminal Functions – External MCU Mode (Continued)

| TERMINAL NAME | NO. | I/O | DESCRIPTION |
|---------------|-----|-----|---|
| MCUAD1 | 25 | I/O | MCU multiplexed address/data bit 1: Multiplexed address bit 1/data bit 1 for external MCU access to the TUSB3200 external data memory space. |
| MCUAD2 | 26 | I/O | MCU multiplexed address/data bit 2: Multiplexed address bit 2/data bit 2 for external MCU access to the TUSB3200 external data memory space. |
| MCUAD3 | 28 | I/O | MCU multiplexed address/data bit 3: Multiplexed address bit 3/data bit 3 for external MCU access to the TUSB3200 external data memory space. |
| MCUAD4 | 29 | I/O | MCU multiplexed address/data bit 4: Multiplexed address bit 4/data bit 4 for external MCU access to the TUSB3200 external data memory space. |
| MCUAD5 | 30 | I/O | MCU multiplexed address/data bit 5: Multiplexed address bit 5/data bit 5 for external MCU access to the TUSB3200 external data memory space. |
| MCUAD6 | 31 | I/O | MCU multiplexed address/data bit 6: Multiplexed address bit 6/data bit 6 for external MCU access to the TUSB3200 external data memory space. |
| MCUAD7 | 32 | I/O | MCU multiplexed address/data bit 7: Multiplexed address bit 7/data bit 7 for external MCU access to the TUSB3200 external data memory space. |
| MCUA8 | 14 | I | MCU address bit 8: Multiplexed address bit 8 for external MCU access to the TUSB3200 external data memory space. |
| MCUA9 | 15 | I | MCU address bit 9: Multiplexed address bit 9 for external MCU access to the TUSB3200 external data memory space. |
| MCUA10 | 18 | I | MCU address bit 10: Multiplexed address bit 10 for external MCU access to the TUSB3200 external data memory space. |
| MCUALE | 19 | I | MCU address latch enable: Address latch enable for external MCU access to the TUSB3200 external data memory space. |
| MCUINTO | 20 | O | MCU interrupt output: Interrupt output to be used for external MCU $\overline{\text{INTO}}$ input signal. All internal TUSB3200 interrupt sources are ORed together to generate this output signal. |
| MCURD | 23 | I | MCU read strobe: Read strobe for external MCU read access to the TUSB3200 external data memory space. |
| MCUWR | 22 | I | MCU write strobe: Write strobe for external MCU write access to the TUSB3200 external data memory space. |
| MRESET | 10 | I | Master reset: An active low asynchronous reset for the device that resets all logic to the default state. This signal uses a 3.3-V TTL/LVCMOS input bufer. |
| Not Used | 4 | O | This pin is not used in the normal mode. |
| PLLFILO | 52 | I | PLL loop filter input: Input to on-chip PLL from external filter components. |
| PLLFILO | 1 | O | PLL loop filter output: Output to on-chip PLL from external filter components. |
| PUR | 6 | O | USB data signal plus pullup resistor connect: PUR is used to connect the pullup resistor on the DP signal to 3.3-V or a 3-state. When the DP signal is connected to 3.3-V the host PC should detect the connection of the TUSB3200 device to the universal serial bus. This signal uses a 3.3-V TTL/LVCMOS output buffer. |
| PWMO | 3 | O | PWM output: Output of the pulse width modulation circuit. This signal uses a 3.3-V to 5-V CMOS level shifting output buffer. |
| RSTO | 13 | O | Reset output: Output that is active while the master reset input or the USB reset is active. This signal uses a 3.3-V TTL/LVCMOS output buffer. |
| SCL | 42 | O | I ² C interface serial clock: SCL is the clock signal for the I ² C serial interface. This signal uses a 3.3-V to 5-V TTL level shifting open drain output buffer. |
| SDA | 41 | I/O | I ² C interface serial data input/output: SDA is the bidirectional data signal for the I ² C serial interface. This signal uses a 3.3-V to 5-V TTL level shifting open drain output buffer and a 5-V to 3.3-V TTL level shifting input buffer. |
| TEST | 11 | I | Test mode enable: Input used to enable the device for the factory test mode. This signal uses a 3.3-V TTL/LVCMOS input bufer. |
| XINT | 17 | I | External interrupt: An active low input used by external circuitry to interrupt the on-chip 8052 MCU. This signal uses a 5-V compatible input bufer. |
| XTALI | 51 | I | Crystal input: Input to the on-chip oscillator from an external 6-MHz crystal. |
| XTALO | 50 | O | Crystal output: Output from the on-chip oscillator to an external 6-MHz crystal. |

1.8 Device Operation Modes

The EXTEN and TEST pins define the mode that the TUSB3200 will be in after reset.

| MODE | EXTEN | TEST |
|----------------------------|-------|------|
| Normal mode – internal MCU | 0 | 0 |
| External MCU mode | 1 | 0 |
| Factory test | 0 | 1 |
| Factory test | 1 | 1 |

1.9 Terminal Assignments for CODEC Port Interface Modes

The CODEC port interface has eight modes of operation that support AC97, I²S, and AIC CODECs. There is also a general-purpose mode that is not specific to a serial interface. The mode is programmed by writing to the mode select field of the CODEC port interface configuration register 1 (CPTCNF1). The CODEC port interface terminals CSYNC, CSCLK, CDATO, CDATI, CRESET, and CSCHNE take on functionality appropriate to the mode programmed as shown in the following tables.

| TERMINAL | | GP Mode 0 | | AIC Mode 1 | | AC '97 v1.X Mode 2 | | AC '97 v2.X Mode 3 | |
|----------|---------------------|---------------------|-----|--------------------|---|--------------------|---|--------------------|---|
| NO. | NAME | | | | | | | | |
| 35 | CSYNC | CSYNC | I/O | \overline{FS} | O | SYNC | O | SYNC | O |
| 34 | CSCLK | CSCLK | I/O | SCLK | O | BIT_CLK | I | BIT_CLK | I |
| 36 | CDATO | CDATO | O | DOUT | O | SD_OUT | O | SD_OUT | O |
| 38 | CDATI | CDATI | I | DIN | I | SD_IN | I | SD_IN1 | I |
| 39 | \overline{CRESET} | \overline{CRESET} | O | \overline{RESET} | O | \overline{RESET} | O | \overline{RESET} | O |
| 40 | CSCHNE | NC | O | FC | O | NC | O | SD_IN2 | I |

| TERMINAL | | I ² S Mode 4 | | I ² S Mode 5 | | I ² S Mode 6 | | I ² S Mode 7 | |
|----------|---------------------|-------------------------|---|-------------------------|---|-------------------------|---|-------------------------|---|
| NO. | NAME | | | | | | | | |
| 35 | CSYNC | LRCK | O | LRCK | O | LRCK | O | LRCK | O |
| 34 | CSCLK | SCLK | O | SCLK | O | SCLK | O | SCLK | O |
| 36 | CDATO | SDOUT1 | O | SDOUT1 | O | SDOUT1 | O | SDOUT1 | O |
| 38 | CDATI | SDOUT2 | O | SDOUT2 | O | SDIN1 | I | SDOUT2 | O |
| 39 | \overline{CRESET} | SDOUT3 | O | SDIN1 | I | SDIN2 | I | SDOUT3 | O |
| 40 | CSCHNE | SDIN1 | I | SDIN2 | I | SDIN3 | I | SDOUT4 | O |

- NOTES:
- Signal names and I/O direction are with respect to the TUSB3200 device. The signal names used for the TUSB3200 terminals for the various CODEC port interface modes reflect the nomenclature used by the CODEC devices.
 - NC indicates no connection for the terminal in a particular mode. The TUSB3200 device drives the signal as an output for these cases.
 - The CSYNC and CSCLK signals can be programmed as either an input or an output in the general-purpose mode.

2 Description

2.1 Architectural Overview

2.1.1 Oscillator and PLL

Using an external 6-MHz crystal, the TUSB3200 derives the fundamental 48-MHz internal clock signal using an on-chip oscillator and PLL. Using the PLL output, the other required clock signals are generated by the clock generator and adaptive clock generator.

2.1.2 Clock Generator and Sequencer Logic

Utilizing the 48-MHz input from the PLL, the clock generator logic generates all internal clock signals, except for the CODEC port interface master clock (MCLK) and serial clock (CSCLK) signals. The TUSB3200 internal clocks include the 48-MHz clock, a 24-MHz clock, a 12-MHz clock and a USB clock. The USB clock also has a frequency of 12-MHz. The USB clock is the same as the 12-MHz clock when the TUSB3200 is transmitting data and is derived from the data when the TUSB3200 is receiving data. To derive the USB clock when receiving USB data, the TUSB3200 utilizes an internal digital PLL (DPLL) that uses the 48-MHz clock.

The sequencer logic controls the access to the SRAM used for the USB endpoint configuration blocks and the USB endpoint buffer space. The SRAM can be accessed by the MCU, USB buffer manager (UBM) or DMA channels. The sequencer controls the access to the memory using a round robin fixed priority arbitration scheme. This basically means that the sequencer logic generates grant signals for the MCU, UBM and DMA channels at a predetermined fixed frequency.

2.1.3 Adaptive Clock Generator (ACG)

The adaptive clock generator is used to generate a master clock output signal (MCLKO) to be used by the CODEC port interface and the CODEC device. To synchronize the sample rate conversion of data by the CODEC to the USB frame rate, the MCLKO signal generated by the adaptive clock generator must be used. The synchronization of the MCLKO signal to the USB frame rate is controlled by the MCU by programming the adaptive clock generator frequency value. The MCLKO frequency is monitored by the MCU and updated as required. For asynchronous operation, an external source can be used to generate a master clock input signal (MCLKI) to be used by the CODEC port interface. In this scenario, the CODEC device should also use the same master clock signal (MCLKI).

2.1.4 USB Transceiver

The TUSB3200 provides an integrated transceiver for the USB port. The transceiver includes a differential output driver, a differential input receiver and two single ended input buffers. The transceiver connects to the USB DP and DM signal terminals.

2.1.5 USB Serial Interface Engine (SIE)

The serial interface engine logic manages the USB packet protocol requirements for the packets being received and transmitted on the USB by the TUSB3200 device. For packets being received, the SIE decodes the packet identifier field (PID) to determine the type of packet being received and to ensure the PID is valid. For token packets and data packets being received, the SIE calculates the packet cycle redundancy check (CRC) and compares the value to the CRC contained in the packet to verify that the packet was not corrupted during transmission. For token packets and data packets being transmitted, the SIE generates the CRC that is transmitted with the packet. For packets being transmitted, the SIE also generates the synchronization field (SYNC) that is an eight bit field at the beginning of each packet. In addition, the SIE generates the correct PID for all packets being transmitted. Another major function of the SIE is the overall serial-to-parallel conversion of the data packets being received and the parallel-to-serial conversion of the data packets being transmitted.

2.1.6 USB Buffer Manager (UBM)

The USB buffer manager provides the control logic that interfaces the SIE to the USB endpoint buffers. One of the major functions of the UBM is to decode the USB function address to determine if the host PC is addressing the TUSB3200 device USB peripheral function. In addition, the endpoint address field and direction signal are decoded to determine which particular USB endpoint is being addressed. Based on the direction of the USB transaction and the endpoint number, the UBM will either write or read the data packet to/from the appropriate USB endpoint data buffer.

2.1.7 USB Frame Timer

The USB frame timer logic receives the start of frame (SOF) packet from the host PC each USB frame. Each frame, the logic stores the 11-bit frame number value from the SOF packet in a register and asserts the internal SOF signal. The frame number register can be read by the MCU and the value can be used as a time stamp. For USB frames in which the SOF packet is corrupted or not received, the frame timer logic will generate a pseudo start of frame (PSOF) signal and increment the frame number register.

2.1.8 USB Suspend and Resume Logic

The USB suspend and resume logic detects suspend and resume conditions on the USB. This logic also provides the internal signals used to control the TUSB3200 device when these conditions occur. The capability to resume operation from a suspend condition with a locally generated remote wake-up event is also provided.

2.1.9 MCU Core

The TUSB3200 uses an 8-bit microcontroller core that is based on the industry standard 8052. The MCU is software compatible with the 8052, 8032, 80C52, 80C53, and 87C52 MCUs. The 8052 MCU is the processing core of the TUSB3200 and handles all USB control, interrupt and bulk endpoint transfers. In addition, the MCU can also be the source or sink for USB isochronous endpoint transfers.

2.1.10 MCU Memory

In accordance with the industry standard 8052, the TUSB3200 MCU memory is organized into program memory, external data memory and internal data memory. A 4K byte boot ROM is used to download the application code to an 8K byte RAM that is mapped to the program memory space. The external data memory includes the USB endpoint configuration blocks, USB data buffers, and memory mapped registers. The total external data memory space used is 2K bytes. A total of 256 bytes are provided for the internal data memory.

2.1.11 USB Endpoint Configuration Blocks and Endpoint Buffer Space

The USB endpoint configuration blocks are used by the MCU to configure and operate the required USB endpoints for a particular application. In addition to the control endpoint, the TUSB3200 supports a total of seven in endpoints and seven out endpoints. A set of six bytes is provided for each endpoint to specify the endpoint type, buffer address, buffer size and data packet byte count.

The USB endpoint buffer space provided is a total of 1832 bytes. The space is totally configurable by the MCU for a particular application. Therefore, the MCU can configure each buffer based on the total number of endpoints to be used, the maximum packet size to be used for each endpoint, and the selection of single or double buffering.

2.1.12 DMA Controller

Four DMA channels are provided to support the streaming of data for USB isochronous endpoints. Each DMA channel can support one USB isochronous endpoint, either in or out. The DMA channels are used to stream data between the USB endpoint data buffers and the CODEC port interface. The USB endpoint number and direction can be programmed for each DMA channel. Also, the CODEC port interface time slots to be serviced by each DMA channel can be programmed.

2.1.13 CODEC Port Interface

The TUSB3200 provides a configurable full duplex bidirectional serial interface that can be used to connect to a CODEC or another device for streaming USB Isochronous data. The interface can be configured to support several different industry standard protocols, including AC '97 1.X, AC '97 2.X and I²S.

2.1.14 I²C Interface

The I²C interface logic provides a two-wire serial interface that can be used by the 8052 MCU to access other ICs. The TUSB3200 is an I²C master device only and supports single byte or multiple byte read and write operations. The interface can be programmed to operate at either 100 kbps or 400 kbps. In addition, the protocol supports 8-bit or 16-bit addressing for accessing the I²C slave device memory locations.

2.1.15 Pulse Width Modulation (PWM) Output

The TUSB3200 provides a pulse width modulation output with programmable frequency and pulse width. The frequency can be programmed from 732 Hz to 93.7 kHz with an 8-bit register. The pulse width of the output signal is set with a 16-bit register.

2.1.16 General-Purpose IO Ports (GPIO)

The TUSB3200 provides two general-purpose IO ports that are controlled by the internal 8052 MCU. The two ports, port 1 and port 3, are 8-bits and 5-bits, respectively. Note that port 3 bit locations 2, 6, and 7 have been used in the TUSB3200 for other functionality. Therefore these three bit locations are not available for GPIO use. Port 3 bit location 2 has been used as the external interrupt (\overline{XINT}) input to the TUSB3200. Port 3 bit locations 6 and 7 have been used as the external MCU write strobe and read strobe inputs for the external MCU mode of operation.

Each bit of both ports can be independently used as either an input or output. Hence each port bit consists of an output buffer, an input buffer and a pullup resistor. The pullup resistors on the GPIO pins can be disabled using the PUDIS bit in the global control register.

2.1.17 Interrupt Logic

The interrupt logic monitors the various conditions that can cause an interrupt and asserts the interrupt 0 (INT0) input to the 8052 MCU accordingly. All of the TUSB3200 internal interrupt sources and the external interrupt (\overline{XINT}) input are ORed together to generate the INT0 signal. An interrupt vector register is provided that is used by the MCU to identify the interrupt source.

2.1.18 Reset Logic

An external master reset (\overline{MRESET}) input signal that is asynchronous to the internal clocks is used to reset the TUSB3200 logic. In addition to the master reset, the TUSB3200 logic can be reset with the USB reset from the host PC. The TUSB3200 also provides a reset output (\overline{RSTO}) signal that can be used by external devices. This signal is asserted when either a master reset or USB reset occurs.

2.2 Device Operation

The operation of the TUSB3200 is explained in the following sections. For additional information on USB, refer to the universal serial bus Specification version 1.1.

2.2.1 Clock Generation

The TUSB3200 requires an external 6-MHz crystal and PLL loop filter components connected as shown in Figure 4-1 to derive all the clocks needed for both USB and CODEC operation. Using the low frequency 6-MHz crystal and generating the required higher frequency clocks internal to the IC is a major advantage regarding EMI.

2.2.2 Device Initialization

After a power-on reset is applied to the TUSB3200 device, the 8052 MCU will execute a boot loader program from the 4K byte boot ROM mapped to the program memory space. During device initialization, the boot loader program downloads the application program code from an external EEPROM through the I²C interface. This requires that a binary image of the application code be written to the 8K byte code RAM in the TUSB3200 device.

All memory mapped registers are initialized to a default value as defined in Appendix A, *MCU Memory and Memory-Mapped Registers*. The TUSB3200 device powersup with a default function address of zero and disconnected from the USB.

2.2.2.1 Boot Load from EEPROM

Loading the application code from an external serial EEPROM requires a preprogrammed memory device containing an informative header and the application code. While the application code is being downloaded, the TUSB3200 will remain disconnected from the USB. When the code download is complete, execution of the application code should connect the TUSB3200 to the USB. In this situation, the TUSB3200 will enumerate using the vendor ID and product ID contained in the application code.

2.2.2.2 EEPROM Header

For both application code and USB device information stored in a EEPROM device, a common header format is used that proceeds the data payload. Table 2-1 shows the format and information contained in the header.

Table 2–1. EEPROM Header

| OFFSET | TYPE | SIZE | VALUE |
|--------|-------------|------|--|
| 0 | Signature | 4 | 0x04513200 |
| 4 | Header size | 1 | Header size |
| 5 | Version | 1 | Firmware version |
| 6 | EEPROM type | 1 | 0x01 = Reserved 0x02 = Reserved 0x03 = Reserved 0x04 = Reserved 0x05 = Reserved 0x06 = Reserved 0x07 = Reserved 0x08 = Reserved 0x09 = 24C32 0x0A = 24C64 0x0B...0xFF = Reserved |
| 7 | Data type | 1 | 0x01 = Application code 0x02...0xFF = Reserved |
| 8 | Data size | 2 | Data payload only size |
| 10 | Check sum | 2 | Check sum of the data payload beginning at location Check Sum + 2 |
| 12 | Data | - | Data payload |

The *signature* field is used for the detection of a EEPROM device connected to the TUSB3200. The *header size* field supports future updates of the header. Data begins right after the header. The *version* field identifies the header version. The *EEPROM type* field identifies the specific EEPROM device being used. The *data type* field describes the nature of data stored in the EEPROM (application code or USB device information). The *data size* field holds the length of the data payload starting from the end of the header. The *check sum* field contains the check sum for the data payload portion of the EEPROM.

2.2.2.3 EEPROM Data Type

The two types of data that are stored in the EEPROM are application code and USB device information.

2.2.2.3.1 Application Code

Application firmware is stored as a binary image of the code. The binary image is mapped to the MCU program memory space starting at address zero and is stored in the EEPROM as a continuous linear block starting after the header information. A utility program is available that converts a file in Intel hexadecimal format to a binary image data file and appends it to the header.

2.2.2.3.2 USB Device Information

The USB device information is comprised of the vendor ID and product ID. Optionally, a manufacturer string and product string can be included. The boot loader uses this information during enumeration to identify the USB peripheral device. Table 2-2 shows the format and information contained in the *USB Device Information Section*.

Table 2–2. USB Device Information

| OFFSET | TYPE | SIZE | CONTENTS | REMARK |
|------------|--------------------|------|-------------------------------|--------------------|
| H+1 | Vendor ID | 2 | Vendor ID code | |
| H+3 | Product ID | 2 | Product ID code | |
| H+5 | M Offset | 1 | Pointer to manufacture string | String is optional |
| H+6 | P Offset | 1 | Pointer to product string | String is optional |
| H+M Offset | Manufacture string | - | | Null terminated |
| H+P Offset | Product string | - | | Null terminated |

2.2.2.4 EEPROM Device Type

The TUSB3200 boot loader program supports several different types of serial EEPROM devices. The boot loader program will automatically identify the EEPROM type from the header information and use the correct serial interface protocol accordingly. The boot loader program uses an I²C slave device address of A0h for the serial EEPROM device.

These EEPROM devices require an I²C device address in addition to a two byte data word address. These devices require the full 7-bit I²C device address. Depending on the memory size of the EEPROM device being used, the most significant three or four bits of the two byte data word address are don't care bits. The EEPROM types supported are: 24C32 and 24C64

All of these EEPROM devices can be used for storing and loading application code. However most applications will use devices which are capable of storing up to 8K bytes of program code.

2.2.3 USB Enumeration

USB enumeration is accomplished by interaction between the host PC software and the TUSB3200 code. After power-on reset the boot loader code first reads the information from the EEPROM, then runs the application code. The application code connects the TUSB3200 to the USB. During the enumeration, the application code identifies the device as an application specific device and the host loads the appropriate host driver(s). The boot loader and application code both use the CONT, SDW and FRSTE bits to control the enumeration process. The function connect (CONT) bit is set to a 1 by the MCU to connect the TUSB3200 device to the USB. When this bit is set to a 1, the USB data plus pullup resistor (PUR) output signal is enabled, which will connect the pullup on the PCB to the TUSB3200 3.3-V digital supply voltage. When this bit is cleared to a 0, the PUR output is in the 3-state mode. This bit is not affected by a USB reset. The shadow the boot ROM (SDW) bit is set to a 1 by the MCU to switch the MCU memory configuration from boot loader mode to normal operating mode. The function reset enable (FRSTE) bit is set to a 1 by the MCU to enable the USB reset to reset all internal logic including the MCU. However, the shadow the ROM (SDW) and the USB function connect (CONT) bits will not be reset. When this bit is set, the reset output (\overline{RSTO}) signal from the TUSB3200 device will also be active when a USB reset occurs. This bit is not affected by USB reset.

2.2.4 USB Reset

The TUSB3200 can detect a USB reset condition. When the reset occurs, the TUSB3200 responds by setting the function reset (RSTR) bit in the USB status register (USBSTA). If the corresponding function reset bit in the USB

interrupt mask register is set, an MCU interrupt will be generated and the USB function reset (0x17) vector will appear in the interrupt vector register (VECINT).

The function reset enable bit (FRSTE) in the USB control register (USBCTL) is used to control the extent to which the internal logic is reset. The function reset enable bit is set to a 1 by the MCU to enable the USB reset to reset all internal logic including the MCU. However, the shadow the ROM (SDW) and the USB function connect (CONT) bits will not be reset. When this bit is set, the reset output (\overline{RSTO}) signal from the device will also be active when a USB reset occurs. This bit is not affected by USB reset.

2.2.5 USB Suspend and Resume Modes

All USB devices must support the suspend and resume modes. During the suspend mode, USB devices that are bus powered must enter a low power suspend state. If the USB peripheral device is not bus powered, then entering the low power suspend state is not required. A suspend condition is defined as a constant idle state on the bus for more than 3.0ms. A USB device must actually be in the suspend state no more than 10 ms after the suspend condition is detected. There are two ways for the TUSB3200 device to exit the suspend mode, which are 1) detection of USB resume signaling and 2) detection of a local remote wake-up event.

2.2.5.1 USB Suspend Mode

When a suspend condition is detected on the USB, the suspend/resume logic will set the function suspend request bit (SUSR) in the USB status register. As a result, the function suspend request interrupt (SUSR) will be generated. To enter the low power suspend state and disable all TUSB3200 device clocks, the MCU firmware should set the idle mode bit (IDL), which is bit 0 in the MCU power control (PCON) register. The instruction that sets the IDL bit will be the last instruction executed before the MCU goes to idle mode. In idle mode, the MCU status is preserved. Note that the low power suspend state is a state in which the TUSB3200 clocks are disabled and the IC will consume the least amount of power possible.

2.2.5.2 USB Resume Mode

When the TUSB3200 is in a suspend state, any non-idle signaling on the USB will be detected by the suspend/resume logic and device operation will be resumed. As a result of the resume signaling being detected, the TUSB3200 clocks will be enabled, the function resume request bit (RESR) will be set, and the function resume request interrupt (RESR) will be generated. The function resume request interrupt to the MCU will automatically clear the idle mode bit in the PCON register. As a result, MCU operation will resume with servicing the new interrupt. After the RETI from the ISR, the next instruction to be executed will be the one following the instruction that set the IDL bit. Note that if the low power suspend state was not entered by setting the IDL bit, the clocks will already be enabled and the IDL bit will already be cleared.

2.2.5.3 USB Remote Wake-up Mode

The TUSB3200 device has the capability to remotely wake-up the USB by generating resume signaling upstream. Note that this feature must be enabled by the host software with the SET_FEATURE DEVICE_REMOTE_WAKEUP request. The remote wake-up resume signaling should not be generated until the suspend state has been active for at least 5 ms. In addition, the remote wake-up resume signaling must be generated for at least 1ms but for no more than 15 ms. When the TUSB3200 is in the low power suspend state, asserting the external interrupt input (\overline{XINT}) to the device will enable the clocks and generate the XINT interrupt. The XINT interrupt to the MCU will automatically clear the idle mode bit in the PCON register. As a result, MCU operation will resume with servicing the new interrupt. After the RETI from the ISR, the next instruction to be executed will be the one following the instruction that set the IDL bit. Please note that if the low power suspend state was not entered by setting the IDL bit, the clocks will already be enabled and the IDL bit will already be cleared. When the firmware sets the remote wake-up request bit (RWUP) in the USB control register, the suspend/resume logic will generate the resume signaling upstream on the USB.

2.2.6 Power Supply Sequencing

Turning power supplies on and off with a mixed 5-V/3.3-V system is an important consideration. To avoid possible damage to the TUSB3200 device, proper power sequencing is required. The turnon requirement is that the 5-V and

3.3-V power supplies should start ramping from 0 volts and reach 95 percent of the final voltage values within 25 ms of each other. The turnoff requirement is that the 5-V and 3.3-V power supplies should start ramping from the steady-state voltage and reach 5 percent of these values within 25 ms of each other. In addition, the difference between the two voltages should never exceed 3.6-V while turning on or off. Normally, in a mixed voltage system, the 3.3-V supply is generated from a voltage regulator running from the 5-V supply. A voltage regulator, such as the Texas Instrument's TP7133, can be used to meet these power sequencing requirements.

2.2.7 USB Transfers

The TUSB3200 device supports all the USB data transfer types, which are control, bulk, interrupt, and isochronous. In accordance with the USB specification, endpoint zero is reserved for the control endpoint and is bidirectional. In addition to the control endpoint, the TUSB3200 is capable of supporting up to 7 in endpoints and 7 out endpoints. These additional endpoints can be configured as bulk, interrupt, or isochronous endpoints. The MCU handles all control, bulk, and interrupt endpoint transactions. In addition the MCU can handle isochronous endpoint transactions, such as a rate feedback endpoint to the host PC. However, for streaming isochronous data between the host PC and the CODEC interface port, the DMA channels are provided.

2.2.7.1 Controls Transfers

Control transfers are used for configuration, command, and status communication between the host PC and the TUSB3200 device. Control transfers to the TUSB3200 device use in endpoint 0 and out endpoint 0. The three types of control transfers are control write, control write with no data stage, and control read. Note that the control endpoint must be initialized before connecting the TUSB3200 device to the USB.

2.2.7.1.1 Control Write Transfer (Out Transfer)

The host PC uses a control write transfer to write data to the USB function. A control write transfer consists of a setup stage transaction, at least one out data stage transaction, and an in status stage transaction.

The steps to be followed for a control write transfer are as follows:

1. MCU initializes in endpoint 0 and out endpoint 0 by programming the appropriate USB endpoint configuration blocks. This entails programming the buffer size and buffer base address, selecting the buffer mode, enabling the endpoint interrupt, initializing the TOGGLE bit, enabling the endpoint, and clearing the NACK bit for both in endpoint 0 and out endpoint 0.

Setup Stage Transaction:

2. The host PC sends a setup token packet followed by the setup data packet addressed to out endpoint 0. If the data is received without an error, then the UBM will write the data to the setup data packet buffer, set the setup stage transaction (SETUP) bit to a 1 in the USB status register, return an ACK handshake to the host PC, and assert the setup stage transaction interrupt. Note that as long as the setup transaction (SETUP) bit is set to a 1, the UBM will return a NAK handshake for any data stage or status stage transactions regardless of the endpoint 0 NACK or STALL bit values.
3. The MCU services the interrupt and reads the setup data packet from the buffer then decodes the command. If the command is not supported or valid, the MCU should set the STALL bit in the out endpoint 0 configuration byte and the in endpoint 0 configuration byte before clearing the setup stage transaction (SETUP) bit. This will cause the device to return a STALL handshake for any data stage or status stage transactions. After reading the data packet and decoding the command, the MCU should clear the interrupt, which will automatically clear the setup stage transaction status bit. The MCU should also set the TOGGLE bit in the out endpoint 0 configuration byte to a 1. For control write transfers, the PID used by the host for the first out data packet will be a DATA1 PID and the TOGGLE bit must match.

Data Stage Transaction(s):

1. The host PC sends an out token packet followed by a data packet addressed to out endpoint 0. If the data is received without an error, then the UBM will write the data to the endpoint buffer, update the data count value, toggle the TOGGLE bit, set the NACK bit to a 1, return an ACK handshake to the host PC, and assert the endpoint interrupt.
2. The MCU services the interrupt and reads the data packet from the buffer. To read the data packet, the MCU first needs to obtain the data count value. After reading the data packet, the MCU should clear the interrupt and clear the NACK bit to allow the reception of the next data packet from the host PC.
3. If the NACK bit is set to a 1 when the data packet is received, the UBM simply returns a NAK handshake to the host PC. If the STALL bit is set to a 1 when the data packet is received, the UBM simply returns a STALL handshake to the host PC. If a CRC or bit stuff error occurs when the data packet is received, then no handshake is returned to the host PC.

Status Stage Transaction:

1. For in endpoint 0, the MCU updates the data count value to zero, sets the TOGGLE bit to 1, then clears the NACK bit to a 0 to enable the data packet to be sent to the host PC. Note that for a status stage transaction a null data packet with a DATA1 PID is sent to the host PC.
2. The host PC sends an in token packet addressed to in endpoint 0. After receiving the in token, the UBM transmits a null data packet to the host PC. If the data packet is received without errors by the host PC, then an ACK handshake is returned. The UBM will then toggle the TOGGLE bit, set the NACK bit to a 1, and assert the endpoint interrupt.
3. If the NACK bit is set to a 1 when the in token packet is received, the UBM simply returns a NAK handshake to the host PC. If the STALL bit is set to a 1 when the in token packet is received, the UBM simply returns a STALL handshake to the host PC. If no handshake packet is received from the host PC, then the UBM prepares to retransmit the same data packet again.

2.2.7.1.2 Control Write With No Data Stage Transfer (Out Transfer)

The host PC uses a control write transfer to write data to the USB function. A control write with no data stage transfer consists of a setup stage transaction and an in status stage transaction. For this type of transfer, the data to be written to the USB function is contained in the two byte value field of the setup stage transaction data packet.

The steps to be followed for a control write with no data stage transfer are as follows:

1. MCU initializes in endpoint 0 and out endpoint 0 by programming the appropriate USB endpoint configuration blocks. This entails programming the buffer size and buffer base address, selecting the buffer mode, enabling the endpoint interrupt, initializing the TOGGLE bit, enabling the endpoint, and clearing the NACK bit for both in endpoint 0 and out endpoint 0.

Setup Stage Transaction:

2. The host PC sends a setup token packet followed by the setup data packet addressed to out endpoint 0. If the data is received without an error then the UBM will write the data to the setup data packet buffer, set the setup stage transaction (SETUP) bit to a 1 in the USB status register, return an ACK handshake to the host PC, and assert the setup stage transaction interrupt. Note that as long as the setup transaction (SETUP) bit is set to a 1, the UBM will return a NAK handshake for any data stage or status stage transactions regardless of the endpoint 0 NACK or STALL bit values.
3. The MCU services the interrupt and reads the setup data packet from the buffer then decodes the command. If the command is not supported or valid, the MCU should set the STALL bit in the out endpoint 0 configuration byte and the in endpoint 0 configuration byte before clearing the setup stage transaction (SETUP) bit. This will cause the device to return a STALL handshake for an data stage or status stage transactions. After reading the data packet and decoding the command, the MCU should clear the interrupt, which will automatically clear the setup stage transaction status bit.

Data Stage Transaction(s): Note, there are NO data stage transactions for this type of transfer.

Status Stage Transaction:

1. For in endpoint 0, the MCU updates the data count value to zero, sets the TOGGLE bit to 1, then clears the NACK bit to a 0 to enable the data packet to be sent to the host PC. Note that for a status stage transaction a null data packet with a DATA1 PID is sent to the host PC.
2. The host PC sends an in token packet addressed to in endpoint 0. After receiving the in token, the UBM transmits a null data packet to the host PC. If the data packet is received without errors by the host PC, then an ACK handshake is returned. The UBM will then toggle the TOGGLE bit, set the NACK bit to a 1 and assert the endpoint interrupt.
3. If the NACK bit is set to a 1 when the in token packet is received, the UBM simply returns a NAK handshake to the host PC. If the STALL bit is set to a 1 when the in token packet is received, the UBM simply returns a STALL handshake to the host PC. If no handshake packet is received from the host PC, then the UBM prepares to retransmit the same data packet again.

2.2.7.1.3 Control Read Transfer (In Transfer)

The host PC uses a control read transfer to read data to the USB function. A control read transfer consists of a setup stage transaction, at least one in data stage transaction and an out status stage transaction.

The steps to be followed for a control read transfer are as follows:

1. MCU initializes in endpoint 0 and out endpoint 0 by programming the appropriate USB endpoint configuration blocks. This entails programming the buffer size and buffer base address, selecting the buffer mode, enabling the endpoint interrupt, initializing the TOGGLE bit, enabling the endpoint, and clearing the NACK bit for both in endpoint 0 and out endpoint 0.

Setup Stage Transaction:

2. The host PC sends a setup token packet followed by the setup data packet addressed to out endpoint 0. If the data is received without an error then the UBM will write the data to the setup data packet buffer, set the setup stage transaction (SETUP) bit to a 1 in the USB status register, return an ACK handshake to the host PC and assert the setup stage transaction interrupt. Note that as long as the setup transaction (SETUP) bit is set to a 1, the UBM will return a NAK handshake for any data stage or status stage transactions regardless of the endpoint 0 NACK or STALL bit values.
3. The MCU services the interrupt and reads the setup data packet from the buffer then decodes the command. If the command is not supported or valid, the MCU should set the STALL bit in the out endpoint 0 configuration byte and the in endpoint 0 configuration byte before clearing the setup stage transaction (SETUP) bit. This will cause the device to return a STALL handshake for any data stage or status stage transactions. After reading the data packet and decoding the command, the MCU should clear the interrupt, which will automatically clear the setup stage transaction status bit. The MCU should also set the TOGGLE bit in the in endpoint 0 configuration byte to a 1. For control read transfers, the PID used by the host for the first in data packet will be a DATA1 PID.

Data Stage Transaction(s):

1. The data packet to be sent to the host PC is written to the in endpoint 0 buffer by the MCU. The MCU also updates the data count value then clears the in endpoint 0 NACK bit to a 0 to enable the data packet to be sent to the host PC.
2. The host PC sends an in token packet addressed to the in endpoint 0. After receiving the in token, the UBM transmits the data packet to the host PC. IF the data packet is received without errors by the host PC, then an ACK handshake is returned. The UBM will then toggle the TOGGLE bit, set the NACK bit to a 1 and assert the endpoint interrupt.
3. The MCU services the interrupt and prepares to send the next data packet to the host PC.
4. If the NACK bit is set to a 1 when the in token packet is received, the UBM simply returns a NAK handshake to the host PC. IF the STALL bit is set to a 1 when the in token packet is received, the UBM simply returns a STALL handshake to the host PC. If a no handshake packet is received from the host PC, then the UBM prepares to retransmit the same data packet again.
5. MCU continues to send data packets until all data has been sent to the host PC.

Status Stage Transaction:

1. For out endpoint 0, the MCU sets the TOGGLE bit to 1, then clears the NACK bit to a 0 to enable the data packet to be sent to the host PC. Note that for a status stage transaction a null data packet with a DATA1 PID is sent to the host PC.
2. The host PC sends an out token packet addressed to out endpoint 0. If the data packet is received without an error then the UBM will update the data count value, toggle the TOGGLE bit, set the NACK bit to a 1, return an ACK handshake to the host PC and assert the endpoint interrupt.
3. The MCU services the interrupt. If the status stage transaction completed successfully, then the MCU should clear the interrupt and clear the NACK bit.
4. If the NACK bit is set to a 1 when the in data packet is received, the UBM simply returns a NAK handshake to the host PC. If the STALL bit is set to a 1 when the in data packet is received, the UBM simply returns a STALL handshake to the host PC. If a CRC or bit stuff error occurs when the data packet is received, then no handshake is returned to the host PC.

2.2.7.2 Interrupt Transfers

The TUSB3200 supports interrupt data transfers both to and from the host PC. Devices that need to send or receive a small amount of data with a specified service period should use the interrupt transfer type. In endpoints 1 through 7 and out endpoints 1 through 7 can all be configured as interrupt endpoints.

2.2.7.2.1 Interrupt Out Transaction

The steps to be followed for an interrupt out transaction are as follows:

1. MCU initializes one of the out endpoints as an out interrupt endpoint by programming the appropriate USB endpoint configuration block. This entails programming the buffer size and buffer base address, selecting the buffer mode, enabling the endpoint interrupt, initializing the toggle bit, enabling the endpoint, and clearing the NACK bit.
2. The host PC sends an out token packet followed by a data packet addressed to the out endpoint. If the data is received without an error then the UBM will write the data to the endpoint buffer, update the data count value, toggle the toggle bit, set the NACK bit to a 1, return an ACK handshake to the host PC and assert the endpoint interrupt.
3. The MCU services the interrupt and reads the data packet from the buffer. To read the data packet, the MCU first needs to obtain the data count value. After reading the data packet, the MCU should clear the interrupt and clear the NACK bit to allow the reception of the next data packet from the host PC.

4. If the NACK bit is set to a 1 when the data packet is received, the UBM simply returns a NAK handshake to the host PC. If the STALL bit is set to a 1 when the data packet is received, the UBM simply returns a STALL handshake to the host PC. If a CRC or bit stuff error occurs when the data packet is received, then no handshake is returned to the host PC.

NOTE: In double buffer mode for interrupt out transactions, the UBM selects between the X and Y buffer based on the value of the toggle bit. If the toggle bit is a 0, the UBM will write the data packet to the X buffer. If the toggle bit is a 1, the UBM will write the data packet to the Y buffer. When a data packet is received, the MCU could determine which buffer contains the data packet by reading the toggle bit. However, when using double buffer mode, the possibility exists for data packets to be received and written to both the X and Y buffer before the MCU responds to the endpoint interrupt. In this case, by simply using the toggle bit to determine which buffer contains the data packet would not work. Hence, in double buffer mode, the MCU should read the X buffer NACK bit, the Y buffer NACK bit and the toggle bit to determine the status of the buffers.

2.2.7.2.2 *Interrupt In Transaction*

The steps to be followed for an interrupt in transaction are as follows:

1. MCU initializes one of the in endpoints as an in interrupt endpoint by programming the appropriate USB endpoint configuration block. This entails programming the buffer size and buffer base address, selecting the buffer mode, enabling the endpoint interrupt, initializing the toggle bit, enabling the endpoint, and setting the NACK bit.
2. The data packet to be sent to the host PC is written to the buffer by the MCU. The MCU also updates the data count value then clears the NACK bit to a 0 to enable the data packet to be sent to the host PC.
3. The host PC sends an in token packet addressed to the in endpoint. After receiving the in token, the UBM transmits the data packet to the host PC. If the data packet is received without errors by the host PC, then an ACK handshake is returned. The UBM will then toggle the toggle bit, set the NACK bit to a 1 and assert the endpoint interrupt.
4. The MCU services the interrupt and prepares to send the next data packet to the host PC.
5. If the NACK bit is set to a 1 when the in token packet is received, the UBM simply returns a NAK handshake to the host PC. If the STALL bit is set to a 1 when the In token packet is received, the UBM simply returns a STALL handshake to the host PC. If no handshake packet is received from the host PC, then the UBM prepares to retransmit the same data packet again.

NOTE: In double buffer mode for interrupt in transactions, the UBM selects between the X and Y buffer based on the value of the toggle bit. If the toggle bit is a 0, the UBM will read the data packet from the X buffer. If the toggle bit is a 1, the UBM will read the data packet from the Y buffer.

2.2.7.3 Bulk Transfers

The TUSB3200 supports bulk data transfers both to and from the host PC. Devices that need to send or receive a large amount of data without a suitable bandwidth should use the bulk transfer type. In endpoints 1 through 7 and out endpoints 1 through 7 can all be configured as bulk endpoints.

2.2.7.3.1 Bulk Out Transaction

The steps to be followed for a bulk out transaction are as follows:

1. MCU initializes one of the out endpoints as an out bulk endpoint by programming the appropriate USB endpoint configuration block. This entails programming the buffer size and buffer base address, selecting the buffer mode, enabling the endpoint interrupt, initializing the toggle bit, enabling the endpoint, and clearing the NACK bit.
2. The host PC sends an out token packet followed by a data packet addressed to the out endpoint. If the data is received without an error then the UBM will write the data to the endpoint buffer, update the data count value, toggle the toggle bit, set the NACK bit to a 1, return an ACK handshake to the host PC and assert the endpoint interrupt.
3. The MCU services the interrupt and reads the data packet from the buffer. To read the data packet, the MCU first needs to obtain the data count value. After reading the data packet, the MCU should clear the interrupt and clear the NACK bit to allow the reception of the next data packet from the host PC.
4. If the NACK bit is set to a 1 when the data packet is received, the UBM simply returns a NAK handshake to the host PC. If the STALL bit is set to a 1 when the data packet is received, the UBM simply returns a STALL handshake to the host PC. If a CRC or bit stuff error occurs when the data packet is received, then no handshake is returned to the host PC.

NOTE: In double buffer mode for bulk out transactions, the UBM selects between the X and Y buffer based on the value of the toggle bit. If the toggle bit is a 0, the UBM will write the data packet to the X buffer. If the toggle bit is a 1, the UBM will write the data packet to the Y buffer. When a data packet is received, the MCU could determine which buffer contains the data packet by reading the toggle bit. However, when using double buffer mode, data packets may be received and written to both the X and Y buffer before the MCU responds to the endpoint interrupt. In this case, simply using the toggle bit to determine which buffer contains the data packet would not work. Hence, in double buffer mode, the MCU should read the X buffer NACK bit, the Y buffer NACK bit, and the toggle bit to determine the status of the buffers.

2.2.7.3.2 Bulk In Transaction

The steps to be followed for a bulk in transaction are as follows:

1. MCU initializes one of the in endpoints as an in bulk endpoint by programming the appropriate USB endpoint configuration block. This entails programming the buffer size and buffer base address, selecting the buffer mode, enabling the endpoint interrupt, initializing the toggle bit, enabling the endpoint, and setting the NACK bit.
2. The data packet to be sent to the host PC is written to the buffer by the MCU. The MCU also updates the data count value then clears the NACK bit to a 0 to enable the data packet to be sent to the host PC.
3. The host PC sends an in token packet addressed to the in endpoint. After receiving the in token, the UBM transmits the data packet to the host PC. If the data packet is received without errors by the host PC, then an ACK handshake is returned. The UBM will then toggle the toggle bit, set the NACK bit to a 1 and assert the endpoint interrupt.
4. The MCU services the interrupt and prepares to send the next data packet to the host PC.
5. If the NACK bit is set to a 1 when the in token packet is received, the UBM simply returns a NAK handshake to the host PC. If the STALL bit is set to a 1 when the In token packet is received, the UBM simply returns a STALL handshake to the host PC. If no handshake packet is received from the host PC, then the UBM prepares to retransmit the same data packet again.

NOTE: In double buffer mode for bulk in transactions, the UBM selects between the X and Y buffer based on the value of the toggle bit. If the toggle bit is a 0, the UBM will read the data packet from the X buffer. If the toggle bit is a 1, the UBM will read the data packet from the Y buffer.

2.2.7.4 Isochronous Transfers

The TUSB3200 supports isochronous data transfers both to and from the host PC. Devices that need to send or receive constant-rate data with a suitable USB bandwidth should use the isochronous transfer type. In endpoints 1 through 7 and out endpoints 1 through 7 can all be configured as isochronous endpoints.

The transfer of isochronous data on the USB requires the use of double buffering. The TUSB3200 provides an X buffer and Y buffer for each isochronous endpoint.

Four DMA channels are also provided to support streaming isochronous data to/from the host PC to/from a CODEC. For isochronous endpoints handled by the MCU, the DMA channels are not used.

2.2.7.4.1 *Isochronous Out Transaction (host PC as source and CODEC as destination)*

The steps to be followed for an isochronous out transaction are as follows:

1. MCU initializes one of the out endpoints as an out isochronous endpoint by programming the appropriate USB endpoint configuration block. This entails programming the buffer size and the buffer base address for both the X and Y buffers and the bytes per sample bits, setting the isochronous endpoint bit, enabling the endpoint, and clearing the NACK bit.
2. The MCU initializes one of the four DMA channels to support the isochronous out endpoint by programming the appropriate DMA configuration registers.
3. The host PC sends an out token packet followed by a data packet addressed to the out endpoint. The UBM writes the data packet to the X (or Y) endpoint buffer, updates the sample count in the data count byte, and sets the X (or Y) buffer NACK bit to a 1. Note that the number of audio samples and not the number of bytes is written to the data count byte. Also, note that there is no endpoint interrupt generated for isochronous endpoints. If a buffer overflow occurs, the UBM will set the overflow bit in the endpoint configuration byte.
4. The DMA channel reads the X (or Y) buffer data count byte to verify that the NACK bit is set and to obtain the sample count in the new data packet. The DMA channel then clears the NACK bit and streams the data to the CODEC port interface. Note that if a new data packet has not been received, the NACK bit will not be set, and the DMA channel will not move any data to the CODEC port interface.

2.2.7.4.2 *Isochronous Out Transaction (host PC as source and MCU as destination)*

The steps to be followed for an isochronous out transaction are as follows:

1. MCU initializes one of the out endpoints as an out isochronous endpoint by programming the appropriate USB endpoint configuration block. This entails programming the buffer size and the buffer base address for both the X and Y buffers and the bytes per sample bits, setting the isochronous endpoint bit, enabling the endpoint, and clearing the NACK bit.
2. The host PC sends an out token packet followed by a data packet addressed to the out endpoint. The UBM writes the data packet to the X (or Y) endpoint buffer, updates the sample count in the data count byte, and sets the X (or Y) buffer NACK bit to a 1. Note that the number of audio samples and not the number of bytes is written to the data count byte. Also, note that there is not an endpoint interrupt generated for isochronous endpoints. If a buffer overflow occurs, the UBM will set the overflow bit in the endpoint configuration byte.
3. After an SOF or PSOF interrupt, the MCU reads the USB frame number register and uses the least significant bit (bit 0) value as the buffer select bit. If bit 0 is a 0 for the current USB frame, then the MCU should access the Y buffer. If bit 0 is a 1 for the current USB frame, then the MCU should access the X buffer.

4. The MCU reads the X (or Y) buffer data count byte to verify that the NACK bit is set and to obtain the sample count in the new data packet. Note that if a new data packet has not been received, the NACK bit will not be set. If there is a valid data packet in the buffer, then the MCU clears the NACK bit and proceeds with reading the data.

2.2.7.4.3 *Isochronous In Transaction (CODEC as source and host PC as destination)*

The steps to be followed for an isochronous in transaction are as follows:

1. MCU initializes one of the in endpoints as an in isochronous endpoint by programming the appropriate USB endpoint configuration block. This entails programming the buffer size and the buffer base address for both the X and Y buffers and the bytes per sample bits, setting the isochronous endpoint bit, enabling the endpoint, and setting the NACK bit.
2. The MCU initializes one of the four DMA channels to support the isochronous in endpoint by programming the appropriate DMA configuration registers.
3. During the current USB frame, the DMA proceeds with reading the data from the CODEC port interface and storing the data in the X (or Y) endpoint buffer. At the end of the current USB frame, the DMA updates the sample count in the data count byte then clears the X (or Y) buffer NACK bit to a 0. If a buffer overflow occurs, the DMA will set the overflow bit in the endpoint configuration byte.
4. The host PC sends an in token packet addressed to the in endpoint. The UBM reads the X (or Y) buffer data count byte to verify the NACK bit is cleared and to obtain the sample count of the new data packet. The UBM reads the data packet from the X (or Y) endpoint buffer then transmits the data to the PC. At the end of the USB transaction, the UBM sets the X (or Y) buffer NACK bit to a 1. Note that if a new data packet has not been written to the buffer by the DMA, then the NACK bit will still be set to a 1 and the UBM will send a null packet to the PC. Also, note that there is not an endpoint interrupt generated for isochronous endpoints.

2.2.7.4.4 *Isochronous In Transaction (MCU as source and host PC as destination)*

The steps to be followed for an isochronous in transaction are as follows:

1. MCU initializes one of the in endpoints as an in isochronous endpoint by programming the appropriate USB endpoint configuration block. This entails programming the buffer size and the buffer base address for both the X and Y buffers and the bytes per sample bits, setting the isochronous endpoint bit, enabling the endpoint, and setting the NACK bit.
2. The host PC sends an in token packet addressed to the in endpoint. The UBM reads the X (or Y) buffer data count byte to verify the NACK bit is cleared and to obtain the sample count of the new data packet. The UBM reads the data packet from the X (or Y) endpoint buffer then transmits the data to the PC. At the end of the USB transaction, the UBM sets the X (or Y) buffer NACK bit to a 1. Note that if a new data packet has not been written to the buffer by the MCU then the NACK bit will still be set to a 1 and the UBM will send a null packet to the PC. Also, note that there is not an endpoint interrupt generated for isochronous endpoints.

2.2.8 Adaptive Clock Generator (ACG)

The adaptive clock generator is used to generate a programmable master clock output signal (MCLKO) that can be used by the CODEC port interface and the CODEC device. The ACG can be used to generate the master clock for the CODEC for USB asynchronous, synchronous, and adaptive modes of operation. However, for the USB asynchronous mode of operation, an external clock can be used to drive the MCLKI signal of the TUSB3200. In this scenario, the MCLKI signal would be used as the clock source for the CODEC port interface instead of the clock output from the ACG.

A block diagram of the adaptive clock generator is shown in Figure 2–1. The frequency synthesizer circuit generates a programmable clock with a frequency range of 12–25 MHz. The output of the frequency synthesizer feeds the divide-by-M circuit, which can be programmed to divide by 1 to 16. As a result, the frequency range of the MCLKO signal is 750 kHz to 25 MHz. The duty cycle of the MCLKO signal is 50% for all programmable MCLKO frequencies.

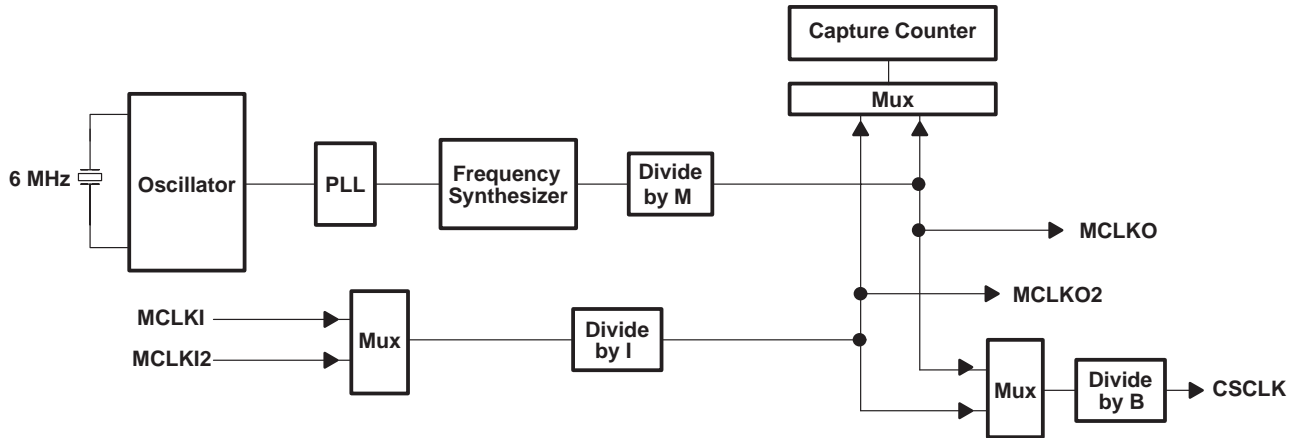

Figure 2–1. Adaptive Clock Generator

The ACG is controller by the following registers. Refer to section A.5.3 for details.

| FUNCTIONAL REGISTER | ACTUAL BYTE-WIDE REGISTERS | | |
|--------------------------------|----------------------------|---------|---------|
| 24-bit Frequency register | ACGFRQ2 | ACGFRQ1 | ACGFRQ0 |
| 16-bit MCLK capture register | | ACGCAPH | ACGCAPL |
| 8-bit Divider control register | | | ACGDCTL |
| 8-bit ACG control register | | | ACGCTL |

The main functional modules of the ACG are described in the following sections.

2.2.8.1 Programmable Frequency Synthesizer

The 24-bit ACG frequency register value is used to program the frequency synthesizer. This results in high resolution to accurately select the desired CODEC master clock frequency. The value of the frequency register may be updated by the MCU while the ACG is running. In audio applications, the firmware can adjust the frequency value by \pm LSB or more to lock onto the USB start-of-frame (SOF) signal to achieve a synchronous mode of operation. The 24-bit frequency register value is updated and used by the frequency synthesizer only when MCU writes to the ACGFRQ0 register.

Depending on the application, a smaller number of bits for controlling the synthesizer frequency can be chosen. The frequency resolution also depends on the actual frequency being used. In general, the frequency resolution is less for higher frequencies and more for lower frequencies. This is due to the fact that the 208 ps frequency resolution becomes more significant compared to the period at higher frequencies than at lower frequencies. The resolution increases with the number of bits used to represent the frequency as the quantization error reduces as more bits are used to represent a fractional number.

The clock frequency of the MCLKO output signal is calculated by using the formula:

$$\text{For } N > 24 \text{ and } N < 50, \text{ MCLKO frequency} = (25/N) \times 192/8 \text{ MHz}$$

$$\text{For } N = 50, \text{ MCLKO frequency} = 96/8 \text{ MHz}$$

Where N is the value in the 24-bit frequency register (ACGFRQ). The value of N can range from 24 to 50. The 6 most significant bits of the 24-bit frequency register are used to represent the integer portion of N and the remaining 18 bits of the frequency register are used to represent the fractional portion of N. An example is shown below.

Example Frequency Register Calculation

Suppose the desired MCLKO frequency is 24.576 MHz. Using the above formula, $N = 24.4140625$ decimal. To determine the binary value to be written to the ACGFRQ register, separately convert the integer value (24) to 6-bit binary and the fractional value (4140625) to 18-bit binary. As a result, the 24-bit binary value is 011000.011010100000000000.

The corresponding values to program into the ACGFRQ registers are:

ACGFRQ2 = 01100001b = 61h

ACGFRQ1 = 10101000b = A8h

ACGFRQ0 = 00000000b = 00h

Keep in mind that writing to the ACGFRQ0 register loads the frequency synthesizer with the new 24-bit value.

Example Frequency Resolution Calculation

To illustrate the frequency resolution capabilities of the ACG, the next possible higher and lower frequencies for MCLKO can be calculated.

To get the next possible higher frequency of MCLKO equal to 24.57600384 MHz, increase the value of N by 1 LSB. Thus, N = 011000.011010100000000001 binary.

To get the next possible lower frequency of MCLKO equal to 24.57599600 MHz, decrease the value of N by 1 LSB. Thus, N = 011000.011010011111111111 binary.

For this example with a nominal MCLKO frequency of 24.576 MHz, the frequency resolution is approximately 4 Hz.

2.2.8.2 Capture Counter and Register

The capture counter and register circuit consists of a 16-bit free running counter which runs at the capture clock frequency. The capture clock source can be selected by using the MCLKCP bit in the ACGCTL register to select either the MCLKO or MCLKO2 signal. With each USB start-of-frame (SOF) signal or pseudo-start-of-frame (PSOF) signal, the capture counter value is stored into the 16-bit capture register. This value is valid until the next SOF or PSOF signal occurs (~1 ms). The MCU can read the 16-bit capture register value by reading the ACGCAPH and ACGCAPL registers.

2.2.9 Microcontroller Unit

The 8052 core used in the TUSB3200 is based on the industry standard 8052 MCU and is software compatible with the 8052, 8032, 80C52, 80C53, and 87C52 MCUs. Therefore, refer to a standard 8052 data manual for more details if needed.

2.2.10 External MCU Mode Operation

The external MCU mode of operation is provided for firmware development using an in-circuit emulator (ICE). In the external MCU mode, the internal 8052 MCU core of the TUSB3200 is disabled. Also in the external MCU mode, the GPIO ports are used for the external MCU data, address, and control signals. Refer to section 1.7, *Terminal Functions – External MCU Mode*, for details. In this mode, the external MCU or ICE is able to access the memory mapped IO registers, the USB configuration blocks and the USB buffer space. Refer to section 1.8, *Device Operation Modes*, for information regarding the various modes of operation.

Texas Instruments has developed the TUSB3200 evaluation module (EVM) to allow customers to develop application firmware and to evaluate device performance. The EVM board provides a 40-pin dip socket for an ICE in addition to headers to allow expansion of the system in a variety of ways.

2.2.11 Interrupt Logic

The 8052 MCU core used in the TUSB3200 supports all the standard interrupt sources. The five standard MCU interrupt sources are timer 0, timer 1, serial port, external 1 (INT1), and external 0 (INT0).

All of the additional interrupt sources within the TUSB3200 device are ORed together to generate the INT0 signal to the MCU. Refer to the interrupt vector register for more details on the other TUSB3200 interrupt sources.

The other interrupt sources are the eight USB in endpoints, the eight USB out endpoints, USB function reset, USB function suspend, USB function resume, USB start-of-frame, USB pseudo start-of-frame, USB setup stage transaction, USB setup stage transaction over-write, CODEC port interface transmit data register empty, CODEC port interface receive data register full, I²C interface transmit data register empty, I²C interface receive data register full, and the external interrupt input.

The interrupts for the USB in endpoints and USB out endpoints can not be masked. An interrupt for a particular endpoint occurs at the end of a successful transaction to that endpoint. A status bit for each in and out endpoint also exists. However, these status bits are read only, and therefore, these bits are intended to be used for diagnostic purposes only. After a successful transaction to an endpoint, both the interrupt and status bit for an endpoint will be asserted until the interrupt is cleared by the MCU.

The USB function reset, USB function suspend, USB function resume, USB start-of-frame, USB pseudo start-of-frame, USB setup stage transaction, and USB setup stage transaction over-write interrupts can all be masked. A status bit for each of these interrupts also exists. Refer to the USB interrupt mask register and the USB status register for more details. Note that the status bits for these interrupts are read only. For these interrupts, both the interrupt and status bit will be asserted until the interrupt is cleared by the MCU.

The CODEC port interface transmit data register empty, CODEC port interface receive data register full, I²C Interface transmit data register empty, and I²C interface receive data register full interrupts can all be masked. A status bit for each of these interrupts also exists. Note that the status bits for these interrupts are read only. However, for these interrupts, the status bits are not cleared automatically when the interrupt is cleared by the MCU. Refer to the CODEC port interface control/status register and the I²C interface control/status register for more details.

The external interrupt input (\overline{XINT}) is also ORed together with the on-chip interrupt sources. An enable bit exists for this interrupt in the global control register. This interrupt does not have a status bit.

2.2.12 DMA Controller

The TUSB3200 provides four DMA channels for transferring data between the USB endpoint buffers and the CODEC port interface. The DMA channels are provided to support the streaming of data for USB isochronous endpoints only. Each DMA channel can be programmed to service only one isochronous endpoint. The endpoint number and direction are programmable using the DMA channel control register provided for each of the four DMA channels.

The CODEC port interface time slots to be serviced by a particular DMA channel must also be programmed. For example, an AC'97 mode stereo speaker application would use time slots 3 and 4 for audio playback. Therefore, the DMA channel being used to move the audio data to the CODEC port interface would need time slot assignment bits 3 and 4 set to a 1. Each DMA channel is capable of being programmed to transfer data for time slots 0 through 13 using the two DMA channel time slot assignment registers provided for each DMA channel.

The number of bytes to be transferred for each time slot is also programmable. The number of bytes used should be set based on the desired audio data format.

2.2.13 CODEC Port Interface

The CODEC port interface is a configurable serial interface used to transfer data between the TUSB3200 IC and a CODEC device. The serial protocol and formats supported include AC '97 1.0, AC '97 2.0 and several I²S modes. In addition, a general purpose mode is provided that can be configured to various user defined serial interface formats.

Configuration of the interface is accomplished using the four CODEC port interface configuration registers, which are CPTCNF1, CPTCNF2, CPTCNF3, and CPTCNF4. Please refer to section A.5.4 for more details on these registers. The serial interface is basically a time division multiplexed (TDM) *time slot based* scheme. The basic serial format is programmed by setting the number of time slots per CODEC frame and the number of serial clock cycles (or bits) per time slot. The interface in all modes is bidirectional and full duplex. For some modes, both audio data and command/status data are transferred via the serial interface. The source of the transmit data and destination of the receive data for all audio data time slots is the USB endpoint data buffers. Transfer of the audio data packets to/from

the USB endpoint data buffers and the CODEC port interface is controlled by one or more of the DMA channels. Remember that each DMA channel can be assigned to one USB isochronous endpoint. The source and/or destination of the command/status address and data values is the MCU.

The features of the CODEC port interface that can be configured are:

- The mode of operation
- The number of time slots per CODEC frame
- The number of serial clock cycles for slot 0
- The number of serial clock cycles for all slots other than slot 0
- The number of valid data bits per audio data time slot
- The time slots to be used for command/status address and data
- The serial clock (CSCLK) frequency in relation to the CODEC master clock (MCLK) frequency
- The source of the serial clock signal; internally generated or an input from the CODEC device
- The source of the CODEC master clock signal used to generate the internal serial clock signal; internally generated by the ACG or an input to the TUSB3200 device
- The polarity, duration, and direction of the CODEC frame sync signal
- The relationship between the CODEC frame sync signal and the serial clock signal
- The relationship between the CODEC frame sync signal and the serial data signals
- The relationship between the serial clock signal and the serial data signals
- The use of zero padding or a 3-state level for unused time slots and/or bits
- The byte ordering to be used

2.2.13.1 Audio CODEC (AC) '97 1.0 Mode of Operation

In AC '97 1.0 mode, the CODEC port interface can be configured as an AC link serial interface to the AC '97 CODEC device. Refer to the Audio CODEC '97 Specification Revision 1.03 for additional information. The AC Link serial interface is a time division multiplexed (TDM) *slot based* serial interface that is used to transfer both audio data and command/status data between the TUSB3200 IC and the CODEC device.

Table 2–3. Terminal Assignments for CODEC Port Interface AC '97 1.0 Mode

| TERMINAL | | AC '97 Version 1.0 MODE 2 | |
|----------|----------------------------|------------------------------|---|
| NO. | NAME | | |
| 35 | CSYNC | SYNC | O |
| 34 | CSCLK | BIT_CLK | I |
| 36 | CDATO | SD_OUT | O |
| 38 | CDATI | SD_IN | I |
| 39 | $\overline{\text{CRESET}}$ | $\overline{\text{RESET}}$ | O |
| 40 | CSCHE | NC | O |

In this mode, the CODEC port interface is configured as a bi-directional full duplex serial interface with a fixed rate of 48 kHz. Each 48-kHz frame is divided into 13 time slots, with the use of each time slot predefined by the Audio CODEC '97 Specification. Each time slot is 20 serial clock cycles in length except for time slot 0, which is only 16 serial clock cycles. The serial clock, which is referred to as the BIT_CLK for AC '97 modes, is set to 12.288 MHz. Based on the length of each slot, there is a total of 256 serial clock cycles per frame at a frequency of 12.288 MHz. As a result the frame frequency is 48 kHz. For the AC '97 modes, the BIT_CLK is input to the TUSB3200 device from the CODEC. The BIT_CLK is generated by the CODEC from the master clock (MCLK) input. The CODEC MCLK input, which can

be generated by the TUSB3200 device, should be a frequency of 24.576 MHz. The start of each 48-kHz frame is synchronized to the rising edge of the SYNC signal, which is an output of the TUSB3200 device. The SYNC signal is driven high each frame for the duration of slot 0. See Figure 2–2 for details on connecting the TUSB3200 to a CODEC device in this mode.



Figure 2–2. Connection of the TUSB3200 to an AC '97 CODEC

The AC link protocol defines slot 0 as a special slot called the *tag slot* and defines slots 1 through 12 as *data slots*. Slot 1 and slot 2 are used to transfer command and status information between the TUSB3200 device and the CODEC. Slot 1 and slot 2 of the outgoing serial data stream are defined as the command address and command data slots, respectively. These slots are used for writing to the control registers in the CODEC. Slot 1 and slot 2 of the incoming serial data stream are defined as the status address and status data slots, respectively. These slots are used for reading from the control registers in the CODEC.

Unused or reserved time slots and unused bit locations within a valid time slot are filled with zeros. Since each data time slot is 20 bits in length, the protocol supports 8-bit, 16-bit, 18-bit or 20-bit data transfers.

2.2.13.2 Audio CODEC (AC) '97 2.0 Mode of Operation

The basic serial protocol for the AC '97 2.0 mode is the same as the AC '97 1.0 mode. The AC '97 2.0 mode, however, offers some additional features. In this mode, the TUSB3200 provides support for multiple CODEC devices and also on-demand sampling. The TUSB3200 can connect directly to two AC '97 CODECs as shown in Figure 2–3. Note that if only one CODEC is used, then the SD_IN2 input (pin 40) should be tied to DVSS.

Table 2–4. Terminal Assignments for CODEC Port Interface AC '97 2.0 Mode

| TERMINAL | | AC '97 Version 2.0 MODE 3 | |
|----------|----------------------------|------------------------------|---|
| NO. | NAME | | |
| 35 | CSYNC | SYNC | O |
| 34 | CSCLK | BIT_CLK | I |
| 36 | CDATO | SD_OUT | O |
| 38 | CDATI | SD_IN1 | I |
| 39 | $\overline{\text{CRESET}}$ | $\overline{\text{RESET}}$ | O |
| 40 | CSCHNE | SD_IN2 | I |

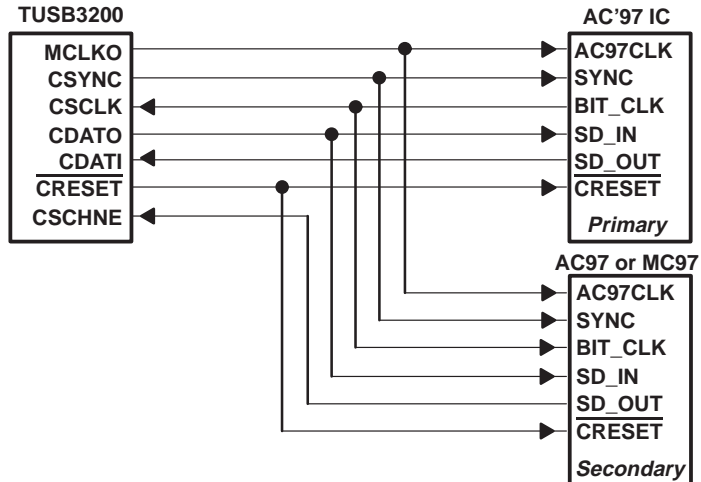

Figure 2–3. Connection of the TUSB3200 to Multiple AC '97 CODECs

2.2.13.3 Inter-IC Sound (I²S) Modes of Operation

The TUSB3200 offers a total of four I²S modes of operation. However, the serial format is the same for all four of the I²S modes. The difference in the I²S modes is simply the number of serial data outputs and/or serial data inputs supported. For instance, in CODEC port interface mode 4, there are three serial data outputs (SDOUT1, SDOUT2, SDOUT3) and one serial data input (SDIN1). Hence, mode 4 can be used to connect the TUSB3200 device to a CODEC with three stereo DACs and one ADC for multichannel audio applications. Note however that not all of the serial data outputs and/or inputs must be used for any given mode. Table 2–5 shows the TUSB3200 CODEC terminal assignments and the respective signal names for each of the I²S modes.

Table 2–5. Terminal Assignments for CODEC Port Interface I²S Modes

| TERMINAL | | I ² S MODE 4 | | I ² S MODE 5 | | I ² S MODE 6 | | I ² S MODE 7 | |
|----------|--------|-------------------------|---|-------------------------|---|-------------------------|---|-------------------------|---|
| NO. | NAME | | | | | | | | |
| 35 | CSYNC | LRCK | O | LRCK | O | LRCK | O | LRCK | O |
| 34 | CSCLK | SCLK | O | SCLK | O | SCLK | O | SCLK | O |
| 36 | CDATO | SDOUT1 | O | SDOUT1 | O | SDOUT1 | O | SDOUT1 | O |
| 38 | CDATI | SDOUT2 | O | SDOUT2 | O | SDIN1 | I | SDOUT2 | O |
| 39 | CRESET | SDOUT3 | O | SDIN1 | I | SDIN2 | I | SDOUT3 | O |
| 40 | CSCHNE | SDIN1 | I | SDIN2 | I | SDIN3 | I | SDOUT4 | O |

In all I²S modes, the CODEC port interface is configured as a bidirectional full duplex serial interface with two time slots per frame. The frame sync signal is the left/right clock (LRCK) signal. Time slot 0 is used for the left channel audio data and time slot 1 is used for the right channel audio data. Both time slots should be set to 32 serial clock (SCLK) cycles in length giving an SCLK-to-LRCK ratio of 64. The serial clock frequency is based on the audio sample rate and the CODEC master clock (MCLK) frequency. For example, when using an audio sample rate (FS) of 48 kHz and an MCLK frequency of 12.288 MHz (256xFS), the SCLK frequency should be set to 3.072 MHz (64xFS). Note that the CODEC frame sync, the audio sample rate (FS), and the LRCK are all synonymous.

The LRCK signal has a 50% duty cycle. The LRCK signal is low for the left channel time slot and is high for the right channel time slot. In addition, the LRCK signal is synchronous to the falling edge of the SCLK. Serial data is shifted out on the falling edge of SCLK and shifted in on the rising edge of SCLK. There is a one SCLK cycle delay from the edge of the LRCK before the most significant bit of the data is shifted out for both the left channel and right channel.

For the I²S modes of the CODEC port interface, there is a 24-bit transmit and 24-bit receive shift register for each SDOUT and SDIN signal, respectively. As a result, the interface can actually support 16-bit, 18-bit, 20-bit or 24-bit transfers. The interface will pad the unused bits automatically with zeros.

The I²S protocol does not provide for command/status data transfers. Therefore, when using the TUSB3200 device with a CODEC that uses an I²S serial interface for audio data transfers, the TUSB3200 I²C serial interface can be used for CODEC command/status data transfers.

In addition, the TUSB3200 CODEC port interface is very flexible. As a result, many variations of the serial interface protocol can be configured including an SCLK-to-LRCK ratio of 32.

2.2.13.3.1 Mapping of DMA Time Slots to CODEC Port Interface Time Slots for I²S Modes

The I²S serial data format requires two time slots (left channel and right channel) for each serial data output or input. As discussed in the previous section, the TUSB3200 can support multiple serial data outputs and/or inputs at the same time in accordance with Table 2–5. Each of the serial data outputs and/or inputs has a unique left channel time slot (slot number 0) and right channel time slot (slot number 1). For the I²S modes of operation, the DMA channel time slot assignments must be mapped to the different left channel and right channel time slots for the serial data outputs and inputs. Each DMA channel has fourteen time slot bits, which are time slot assignment bits 0 through 13. Table 2–6 and 2–7 show the CODEC port interface time slot numbers and the corresponding time slot numbers for the DMA channels.

As an example, suppose that CODEC port interface mode 4 is to be used with three serial data outputs and one serial data input. The DMA channel to be programmed to support the three serial data outputs would need to have time slot assignment bits 0, 1, 2, 4, 5, and 6 set to a 1. The DMA channel to be programmed to support the serial data input would need to have time slot assignment bits 0 and 4 set to a 1.

Table 2–6. SLOT Assignments for CODEC Port Interface I²S Mode (Output)

| SERIAL DATA OUTPUT | CODEC PORT INTERFACE TIME SLOT NUMBER | | DMA CHANNELS(s) TIME SLOT NUMBER | |
|--------------------|---------------------------------------|---------------|----------------------------------|---------------|
| | LEFT CHANNEL | RIGHT CHANNEL | LEFT CHANNEL | RIGHT CHANNEL |
| SDOUT1 | 0 | 1 | 0 | 4 |
| SDOUT2 | 0 | 1 | 1 | 5 |
| SDOUT3 | 0 | 1 | 2 | 6 |
| SDOUT4 | 0 | 1 | 3 | 7 |

Table 2–7. SLOT Assignments for CODEC Port Interface I²S Mode (Input)

| SERIAL DATA INPUT | CODEC PORT INTERFACE TIME SLOT NUMBER | | DMA CHANNELS(s) TIME SLOT NUMBER | |
|-------------------|---------------------------------------|---------------|----------------------------------|---------------|
| | LEFT CHANNEL | RIGHT CHANNEL | LEFT CHANNEL | RIGHT CHANNEL |
| SDIN1 | 0 | 1 | 0 | 4 |
| SDIN2 | 0 | 1 | 1 | 5 |
| SDIN3 | 0 | 1 | 2 | 6 |

2.2.13.4 General-Purpose Mode of Operation

In the general-purpose mode the CODEC port interface can be configured to various user defined serial interface formats using the pin assignments shown in Table 2–8. This mode gives the user the flexibility to configure the TUSB3200 to connect to various CODECs and DSPs that do not use a standard serial interface format.

Table 2–8. Terminal Assignments for CODEC Port Interface General-Purpose Mode

| TERMINAL | | GP MODE 0 | |
|----------|----------------------------|----------------------------|-----|
| NO. | NAME | | |
| 35 | CSYNC | CSYNC | I/O |
| 34 | CSCLK | CSCLK | I/O |
| 36 | CDATO | CDAT0 | O |
| 38 | CDATI | CDAT1 | I |
| 39 | $\overline{\text{CRESET}}$ | $\overline{\text{CRESET}}$ | O |
| 40 | CSCHNE | NC | O |

2.2.14 I²C Interface

The TUSB3200 has a bidirectional two-wire serial interface that can be used to access other ICs. This serial interface is compatible with the I²C (Inter IC) bus protocol and supports both 100-kbps and 400-kbps data transfer rates. The TUSB3200 is a master only device that does not support a multimaster bus environment (no bus arbitration) or wait state insertion. Hence this interface can be used to access I²C slave devices including EEPROMs and CODECs. For example, if the application program code is stored in an EEPROM on the PCB, then the MCU will download the code from the EEPROM to the TUSB3200 on-chip RAM using the I²C interface. Another example is the control of a CODEC device that uses an I²S interface for audio data transfers and an I²C interface for control register read/write access.

2.2.14.1 Data Transfers

The two-wire serial interface uses the serial clock signal, SCL, and the serial data signal, SDA. As stated above, the TUSB3200 is a master only device, and therefore, the SCL signal is an output only. The SDA signal is a bidirectional signal that uses an open-drain output to allow the TUSB3200 to be wire-ORed with other devices that use open-drain or open-collector outputs.

All read and write data transfers on the serial bus are initiated by a master device. The master device is also responsible for generating the clock signal used for all data transfers. The data is transferred on the bus serially one bit at a time. However, the protocol requires that the address and data be transferred in byte (8-bit) format with the most-significant bit (MSB) transferred first. In addition, each byte transferred on the bus is acknowledged by the receiving device with an acknowledge bit. Each transfer operation begins with the master device driving a start condition on the bus and ends with the master device driving a stop condition on the bus.

The timing relationship between the SCL and SDA signals for each bit transferred on the bus is shown in Figure 3-7. As shown, the SDA signal must be stable while the SCL signal is high, which also means that the SDA signal can only change states while the SCL signal is low.

The timing relationship between the SCL and SDA signals for the start and stop conditions is shown in Figure 3-8. As shown, the start condition is defined as a high-to-low transition of the SDA signal while the SCL signal is high. Also as shown, the stop condition is defined as a low-to-high transition of the SDA signal while the SCL signal is high.

When the TUSB3200 is the device receiving data information, the TUSB3200 will acknowledge each byte received by driving the SDA signal low during the acknowledge SCL period. During the acknowledge SCL period, the slave device must stop driving the SDA signal. If the TUSB3200 is unable to receive a byte, the SDA signal will not be driven low and should be pulled high external to the TUSB3200 device. A high during the SCL period indicates a not-acknowledge to the slave device. The acknowledge timing is shown in Figure 3-9.

Read and write data transfers by the TUSB3200 device can be done using single byte or multiple byte data transfers. Therefore, the actual transfer type used depends on the protocol required by the I²C slave device being accessed.

2.2.14.2 Single Byte Write

As shown in Figure 2-4, a single byte data write transfer begins with the master device transmitting a start condition followed by the I²C device address and the read/write bit. The read/write bit determines the direction of the data transfer. For a write data transfer, the read/write bit should be a 0. After receiving the correct I²C device address and the read/write bit, the I²C slave device should respond with an acknowledge bit. Next, the TUSB3200 should transmit the address byte or bytes corresponding to the I²C slave device internal memory address being accessed. After receiving the address byte, the I²C slave device should again respond with an acknowledge bit. Next, the TUSB3200 device should transmit the data byte to be written to the memory address being accessed. After receiving the data byte, the I²C slave device should again respond with an acknowledge bit. Finally, the TUSB3200 device should transmit a stop condition to complete the single byte data write transfer.

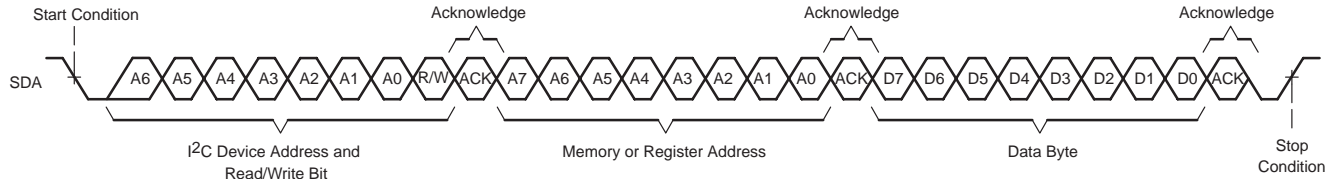

Figure 2-4. Single Byte Write Transfer

2.2.14.3 Multiple Byte Write

A multiple byte data write transfer is identical to a single byte data write transfer except that multiple data bytes are transmitted by the TUSB3200 device to the I²C slave device as shown in Figure 2-5. After receiving each data byte, the I²C slave device should respond with an acknowledge bit.

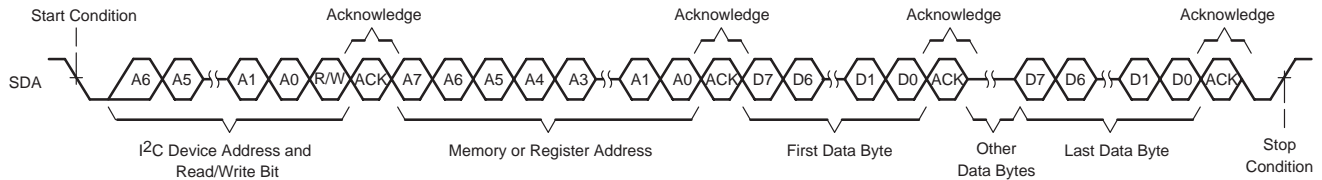

Figure 2-5. Multiple Byte Write Transfer

2.2.14.4 Single Byte Read

As shown in Figure 2-6, a single byte data read transfer begins with the TUSB3200 device transmitting a start condition followed by the I²C device address and the read/write bit. For the data read transfer, both a write followed by a read are actually done. Initially, a write is done to transfer the address byte or bytes of the internal memory address to be read. As a result, the read/write bit should be a 0. After receiving the I²C device address and the read/write bit, the I²C slave device should respond with an acknowledge bit. Also, after sending the internal memory address byte or bytes, the TUSB3200 device should transmit another start condition followed by the I²C slave device address and the read/write bit again. This time the read/write bit should be a 1 indicating a read transfer. After receiving the I²C device address and the read/write bit the I²C slave device should again respond with an acknowledge bit. Next, the I²C slave device should transmit the data byte from the memory address being read. After receiving the data byte, the TUSB3200 device should transmit a not-acknowledge followed by a stop condition to complete the single byte data read transfer.

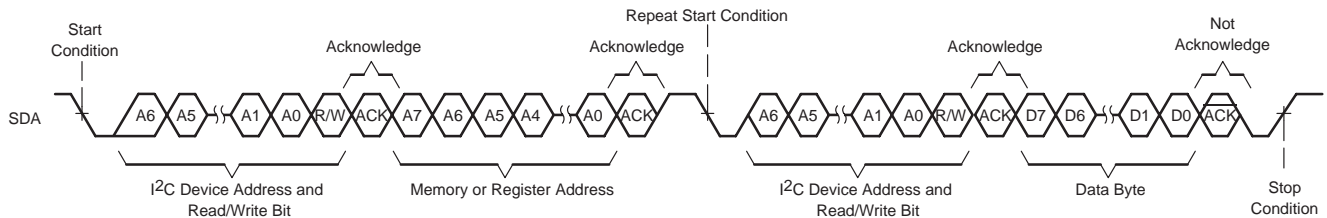

Figure 2-6. Single Byte Read Transfer

2.2.14.5 Multiple Byte Read

A multiple byte data read transfer is identical to a single byte data read transfer except that multiple data bytes are transmitted by the I²C slave device to the TUSB3200 device as shown in Figure 2-7. Except for the last data byte, the TUSB3200 device should respond with an acknowledge bit after receiving each data byte.

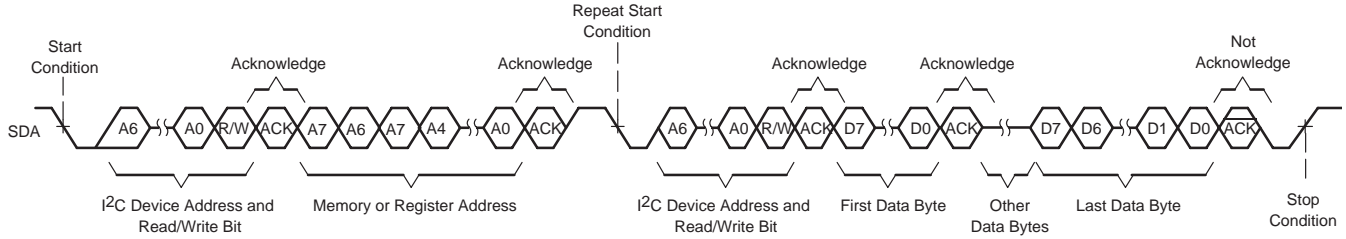

Figure 2-7. Multiple Byte Read Transfer

3 Electrical Specifications

3.1 Absolute Maximum Ratings Over Operating Temperature Ranges (unless otherwise noted)†

| | |
|---|------------------------------|
| Supply voltage range, DV_{DD} | –0.5 to 3.6 V |
| DV_{DDS} | –0.5 to 5.5 V |
| AV_{DD} | –0.5 to 3.6 V |
| Input voltage range, V_I : 3.3-V TTL/LVCMOS | –0.5 V to $DV_{DD} + 0.5$ V |
| 5-V Compatible | –0.5 V to $DV_{DDS} + 0.5$ V |
| 5-V–3.3-V TTL level shifting | –0.5 V to $DV_{DDS} + 0.5$ V |
| Output voltage range, V_O : 3.3-V TTL/LVCMOS | –0.5 V to $DV_{DD} + 0.5$ V |
| 5-V Compatible | –0.5 V to $DV_{DDS} + 0.5$ V |
| 3.3-V–5-V TTL level shifting | –0.5 V to $DV_{DDS} + 0.5$ V |
| 3.3-V–5-V CMOS level shifting | –0.5 V to $DV_{DDS} + 0.5$ V |
| Input clamp current, I_{IK} ($V_I < 0$ or $V_I > DV_{DD}$) | ±20 mA |
| Output clamp current, I_{OK} ($V_O < 0$ or $V_O > DV_{DD}$) | ±20 mA |
| Storage temperature range, T_{stg} | –65°C to 150°C |

† Stresses beyond those listed under “absolute maximum ratings” may cause permanent damage to the device. These are stress ratings only and functional operation of the device at these or any other conditions beyond those indicated under “recommended operating conditions” is not implied. Exposure to absolute-maximum-rated conditions for extended periods may affect device reliability.

3.2 Recommended Operating Conditions

| | | MIN | NOM | MAX | UNITS |
|--|--|-----|-----|------------|-------|
| Digital supply voltage, DV_{DD} | | 3 | 3.3 | 3.6 | V |
| Secondary digital supply voltage, DV_{DDS} | | 4.5 | 5 | 5.5 | V |
| Analog supply voltage, AV_{DD} | | 3 | 3.3 | 3.6 | V |
| High-level input voltage, V_{IH} | 3.3-V TTL/LVCMOS (EXTEN, \overline{MRESET} , TEST) | 2 | | DV_{DD} | V |
| | 5-V compatible TTL/LVCMOS (CSCLK, CSYNC, CDATO, CDATI, \overline{CRESET} , CSCHNE, P1, P3, PLLOEN, \overline{XINT}) | 2 | | DV_{DDS} | |
| | 5-V – 3.3-V TTL level shifting (MCLKI, MCLKI2, SDA) | 2 | | DV_{DDS} | |
| Low-level input voltage, V_{IL} | 3.3-V TTL/LVCMOS (EXTEN, \overline{MRESET} , TEST) | 0 | | 0.8 | V |
| | 5-V compatible TTL/LVCMOS (CSCLK, CSYNC, CDATO, CDATI, \overline{CRESET} , CSCHNE, P1, P3, PLLOEN, \overline{XINT}) | 0 | | 0.8 | |
| | 5-V – 3.3-V TTL level shifting (MCLKI, MCLKI2, SDA) | 0 | | 0.8 | |
| Input voltage, V_I | 3.3-V TTL/LVCMOS (EXTEN, \overline{MRESET} , TEST) | 0 | | DV_{DD} | V |
| | 5-V compatible TTL/LVCMOS (CSCLK, CSYNC, CDATO, CDATI, \overline{CRESET} , CSCHNE, P1, P3, PLLOEN, \overline{XINT}) | 0 | | DV_{DDS} | |
| | 5-V – 3.3-V TTL level shifting (MCLKI, MCLKI2, SDA) | 0 | | DV_{DDS} | |
| Output voltage, V_O | 3.3-V TTL/LVCMOS (MCLKO, MCLKO2, PLLO, PUR, \overline{RSTO}) | 0 | | DV_{DD} | V |
| | 5-V compatible TTL/LVCMOS (CSCLK, CSYNC, CDATO, CDATI, \overline{CRESET} , CSCHNE, P1, P3) | 0 | | DV_{DD} | |
| | 3.3-V – 5-V TTL level shifting, open drain (SCL, SDA) | 0 | | DV_{DDS} | |
| | 3.3-V – 5-V CMOS level shifting (PWMO) | 0 | | DV_{DDS} | |
| Input transition time, t_t (t_r and t_f , 10% to 90%) | | 0 | | 6 | ns |
| Operating ambient air temperature range, T_A | | 0 | 25 | 70 | °C |
| Operating junction temperature range, T_J | | 0 | 25 | 115 | °C |

3.3 Electrical Characteristics Over Recommended Operating Conditions (unless otherwise noted)

| PARAMETER | | TEST CONDITIONS | MIN | TYP | MAX | UNITS |
|-----------------|-------------------------------|----------------------------------|--|-----|-----------------------|-------|
| V _{OH} | High-level output voltage | I _{OH} = -4 mA | 3.3-V TTL/LVCMOS (MCLKO, MCLKO2, PLL0, PUR, RSTO) | | DV _{DD} -0.5 | V |
| | | | 5-V compatible TTL/LVCMOS (CSCLK, CSYNC, CDATO, CDATI, CRESET, CSCHNE, P1, P3) | | DV _{DD} -0.5 | |
| | | | 3.3-V – 5-V CMOS level shifting (PWMO) | | DV _{DD} -0.5 | |
| V _{OL} | Low-level output voltage | I _{OL} = 4 mA | 3.3-V TTL/LVCMOS (MCLKO, MCLKO2, PLL0, PUR, RSTO) | | 0.5 | V |
| | | | 5-V compatible TTL/LVCMOS (CSCLK, CSYNC, CDATO, CDATI, CRESET, CSCHNE, P1, P3) | | 0.5 | |
| | | | 3.3-V – 5-V TTL level shifting, open drain (SCL, SDA) | | 0.5 | V |
| | | | 3.3-V – 5-V CMOS level shifting (PWMO) | | 0.5 | |
| I _{OZ} | High-impedance output current | | 3.3-V TTL/LVCMOS (MCLKO, MCLKO2, PLL0, PUR, RSTO) | | ±20 | μA |
| | | | 5-V compatible TTL/LVCMOS (CSCLK, CSYNC, CDATO, CDATI, CRESET, CSCHNE, P1, P3) | | ±20 | |
| | | | 3.3-V – 5-V TTL level shifting, open drain (SCL, SDA) | | ±20 | |
| I _{IL} | Low-level input current | V _I = V _{IL} | 3.3-V TTL/LVCMOS (EXTEN, MRESET, TEST) | | -20 | μA |
| | | | 5-V compatible TTL/LVCMOS (CSCLK, CSYNC, CDATO, CDATI, CRESET, CSCHNE, P1, P3, PLL0EN, XINT) | | -20 | |
| | | | 5-V – 3.3-V TTL level shifting (MCLKI, MCLKI2, SDA) | | -20 | |
| I _{IH} | High-level input current | V _I = V _{IH} | 3.3-V TTL/LVCMOS (EXTEN, MRESET, TEST) | | 20 | μA |
| | | | 5-V compatible TTL/LVCMOS (CSCLK, CSYNC, CDATO, CDATI, CRESET, CSCHNE, P1, P3, PLL0EN, XINT) | | 20 | |
| | | | 5-V–3.3-V TTL level shifting (MCLKI, MCLKI2, SDA) | | 20 | |
| I _{DD} | Input supply current | | Digital supply voltage, DV _{DD} | | 55 | mA |
| | | | Secondary digital supply voltage, DV _{DDS} | | 5 | |
| | | | Analog supply voltage, AV _{DD} | | 5 | |

3.4 Timing Characteristics

3.4.1 Clock and Control Signals Over Recommended Operating Conditions (unless otherwise noted)

| PARAMETER | TEST CONDITIONS | MIN | TYP | MAX | UNITS |
|--|------------------------------------|-----|-----|-----|-------|
| f _{MCLKO} Clock frequency, MCLKO | C _L = 50 pF, See Note 1 | 1 | | 25 | MHz |
| f _{MCLKO2} Clock frequency, MCLKO2 | C _L = 50 pF, See Note 1 | 1 | | 25 | MHz |
| f _{MCLKI} Clock frequency, MCLKI | See Note 1 | 5 | | 25 | MHz |
| f _{MCLKI2} Clock frequency, MCLKI2 | See Note 1 | 5 | | 25 | MHz |
| t _{w(L)} Pulse duration, $\overline{\text{XINT}}$ low | C _L = 50 pF | 0.2 | | 10 | μs |

NOTE 1: Worst case duty cycle is 45/55.

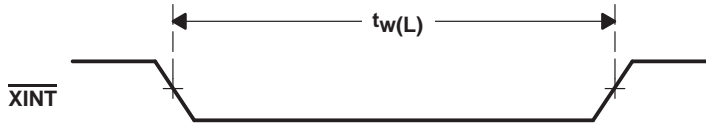

Figure 3–1. External Interrupt Timing Waveform

3.4.2 USB Transceiver Signals Over Recommended Operating Conditions (unless otherwise noted)

| PARAMETER | TEST CONDITIONS | MIN | TYP | MAX | UNITS |
|---|---|-----|-----|------|-------|
| t _r Transition rise time for DP or DM | | 4 | | 20 | ns |
| t _f Transition fall time for DP or DM | | 4 | | 20 | ns |
| t _{RFM} Rise/fall time matching | (t _r /t _f) × 100 | 90% | | 110% | |
| V _{O(CRS)} Voltage output signal crossover | | 1.3 | | 2 | V |

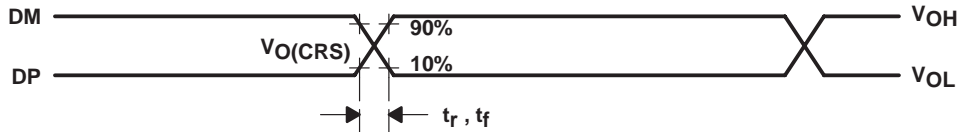

Figure 3–2. USB Differential Driver Timing Waveform

3.4.3 CODEC Port Interface Signals (AC '97 Modes), $T_A = 25^\circ\text{C}$, $DV_{DD} = 3.3\text{ V}$, $DV_{DSS} = 5\text{ V}$, $AV_{DD} = 3.3\text{ V}$

| PARAMETER | | TEST CONDITIONS | MIN | TYP | MAX | UNITS |
|-----------------------|--|----------------------|-----|--------|-----|---------------|
| $f_{\text{BIT_CLK}}$ | Frequency, BIT_CLK | See Note 1 | | 12.288 | | MHz |
| t_{cyc1} | Cycle time, BIT_CLK | See Note 1 | | 81.4 | | ns |
| $t_{w1(H)}$ | Pulse duration, BIT_CLK high | See Note 1 | 36 | 40.7 | 45 | ns |
| $t_{w1(L)}$ | Pulse duration, BIT_CLK low | See Note 1 | 36 | 40.7 | 45 | ns |
| f_{SYNC} | Frequency, SYNC | $C_L = 50\text{ pF}$ | | 48 | | kHz |
| t_{cyc2} | Cycle time, SYNC | $C_L = 50\text{ pF}$ | | 20.8 | | μs |
| $t_{w2(H)}$ | Pulse duration, SYNC high | $C_L = 50\text{ pF}$ | | 1.3 | | μs |
| $t_{w2(L)}$ | Pulse duration, SYNC low | $C_L = 50\text{ pF}$ | | 19.5 | | μs |
| t_{pd1} | Propagation delay time, BIT_CLK rising edge to SYNC, SD_OUT and <u>RESET</u> | $C_L = 50\text{ pF}$ | | | 15 | ns |
| t_{su} | Setup time, SD_IN to BIT_CLK falling edge | | 10 | | | ns |
| t_{h} | Hold time, SD_IN from BIT_CLK falling edge | | 10 | | | ns |

NOTE 1: Worst case duty cycle is 45/55.

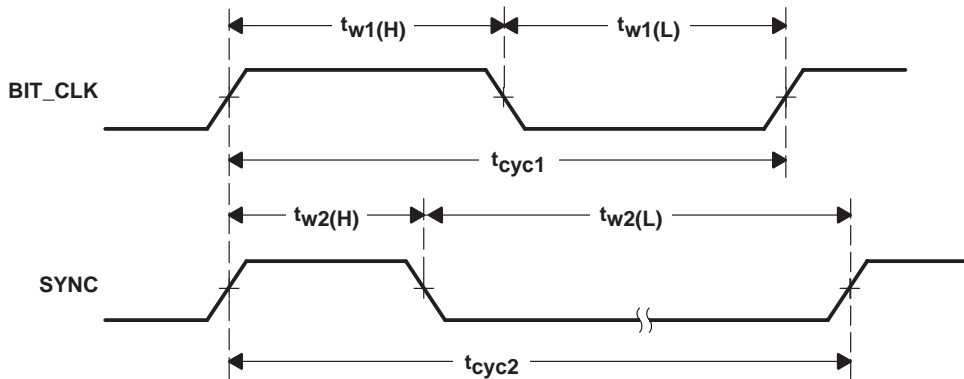

Figure 3-3. BIT_CLK and SYNC Timing Waveforms

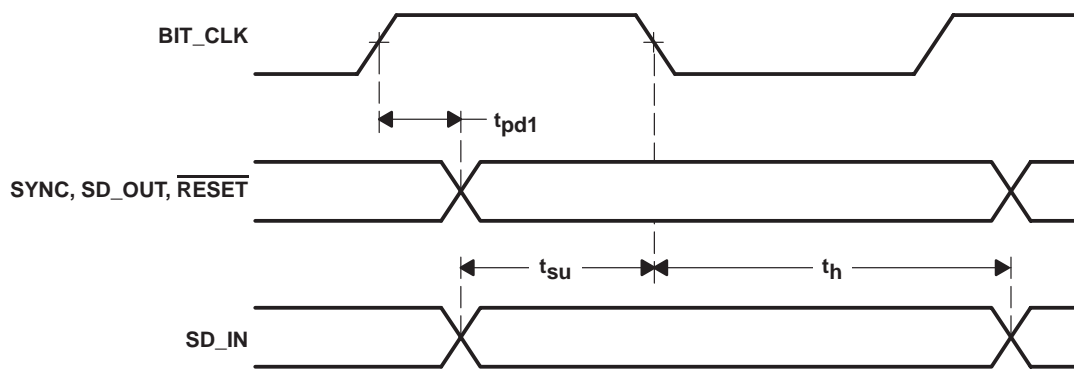

Figure 3-4. SYNC, SD_IN, and SD_OUT Timing Waveforms

3.4.4 CODEC Port Interface Signals (I²S Modes) Over Recommended Operating Conditions (unless otherwise noted)

| PARAMETER | TEST CONDITIONS | MIN | TYP | MAX | UNITS |
|---|------------------------------------|----------------------|----------------------|-----|-------|
| f _{SCLK} Frequency, SCLK | C _L = 50 pF | (32)F _S | (64)F _S | | MHz |
| t _{cyc} Cycle time, SCLK | C _L = 50 pF, See Note 1 | 1/(64)F _S | 1/(32)F _S | | ns |
| t _{pd} Propagation delay, SCLK falling edge to LRCLK and SDOUT | C _L = 50 pF | | | 15 | ns |
| t _{su} Setup time, SDIN to SCLK rising edge | | 10 | | | ns |
| t _h Hold time, SDIN from SCLK rising edge | | 10 | | | ns |

NOTE 1: Worst case duty cycle is 45/55.

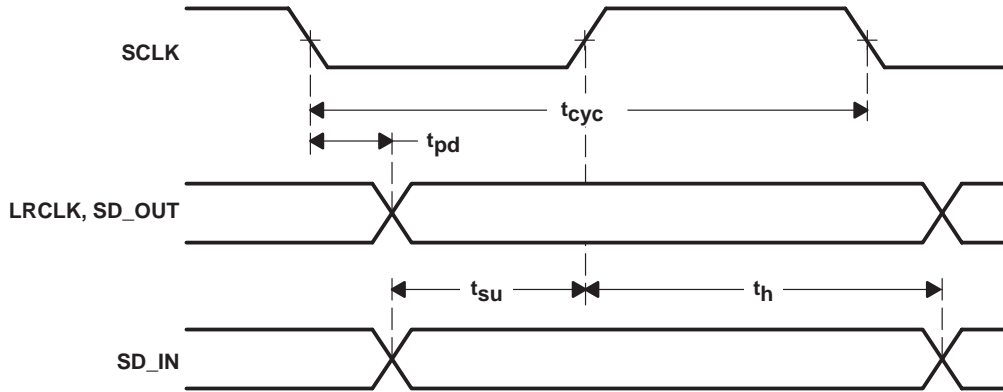

Figure 3–5. I²S Mode Timing Waveforms

3.4.5 CODEC Port Interface Signals (General Purpose Mode) Over Recommended Operating Conditions (unless otherwise noted)

| PARAMETER | TEST CONDITIONS | MIN | TYP | MAX | UNITS |
|---|------------------------------------|-------|-----|-----|-------|
| f _{CSCLK} Frequency, CSCLK | C _L = 50 pF | 0.125 | 25 | | MHz |
| t _{cyc} Cycle time, CSCLK | C _L = 50 pF, See Note 2 | 0.040 | 8 | | μs |
| t _{pd} Propagation delay, CSCLK to CSYNC, CDATO, CSCHNE and CRESET | C _L = 50 pF | | | 15 | ns |
| t _{su} Setup time, CDATI to CSCLK | | 10 | | | ns |
| t _h Hold time, CDATI from CSCLK | | 10 | | | ns |

NOTE 2: The timing waveforms in Figure 3-6 show the CSYNC, CDATO, CSCHNE and CRESET signals generated with the rising edge of the clock and the CDATI signal sampled with the falling edge of the clock. The edge of the clock used is programmable. However, the timing characteristics are the same regardless of which edge of the clock is used.

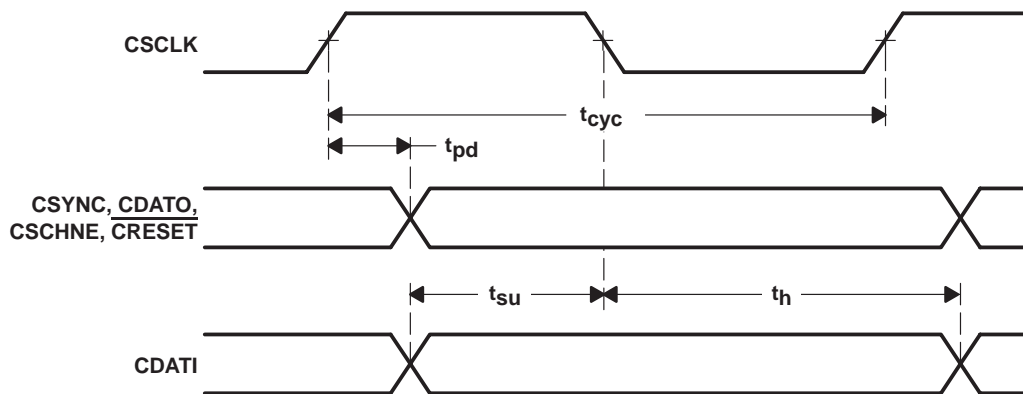

Figure 3–6. General-Purpose Mode Timing Waveforms

3.4.6 I²C Interface Signals Over Recommended Operating Conditions (unless otherwise noted)

| PARAMETER | TEST CONDITIONS | STANDARD MODE | | FAST MODE | | UNITS |
|---|-----------------|---------------|------|-----------|-----|-------|
| | | MIN | MAX | MIN | MAX | |
| f _{SCL} Frequency, SCL | | 0 | 100 | 0 | 400 | kHz |
| t _{w(H)} Pulse duration, SCL high | | 4 | | 0.6 | | μs |
| t _{w(L)} Pulse duration, SCL low | | 4.7 | | 1.3 | | μs |
| t _r Rise time, SCL and SDA | | | 1000 | | 300 | ns |
| t _f Fall time, SCL and SDA | | | 300 | | 300 | ns |
| t _{su1} Setup time, SDA to SCL | | 250 | | 100 | | ns |
| t _{h1} Hold time, SCL to SDA | | 0 | | 0 | | ns |
| t _{buf} Bus free time between stop and start condition | | 4.7 | | 1.3 | | μs |
| t _{su2} Setup time, SCL to start condition | | 4.7 | | 0.6 | | μs |
| t _{h2} Hold time, start condition to SCL | | 4 | | 0.6 | | μs |
| t _{su3} Setup time, SCL to stop condition | | 4 | | 0.6 | | μs |
| C _L Load capacitance for each bus line | | | 400 | | 400 | pF |

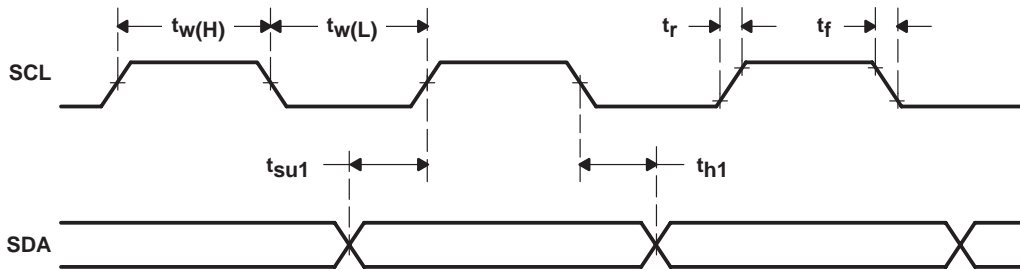

Figure 3–7. SCL and SDA Timing Waveforms

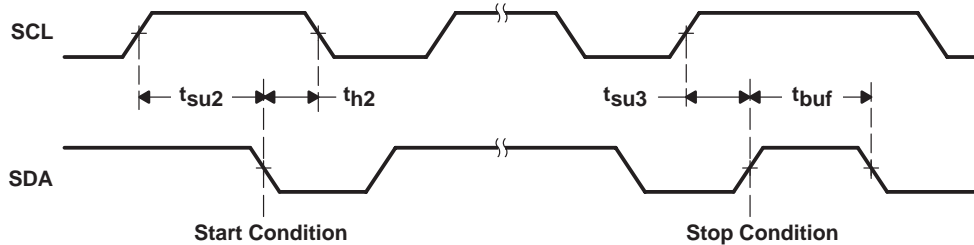

Figure 3–8. Start and Stop Conditions Timing Waveforms

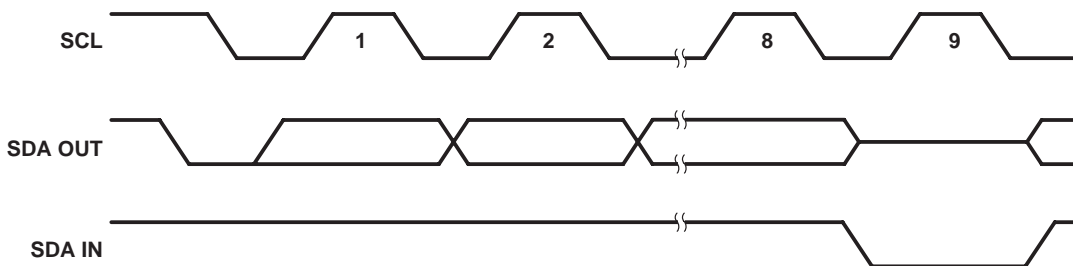

Figure 3–9. Acknowledge Timing Waveform

4 Application Information

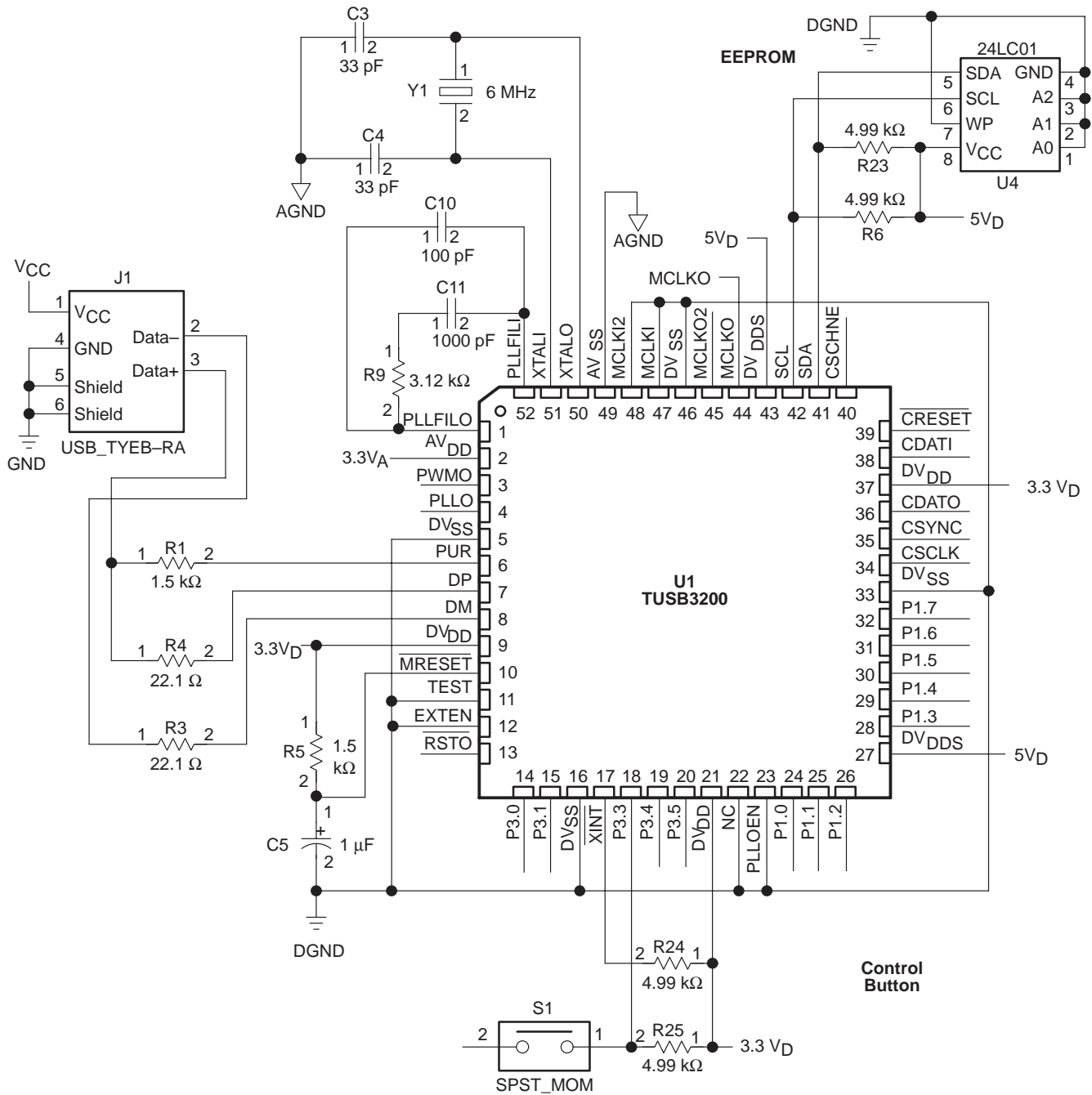

Figure 4–1. Typical TUSB3200 Device Connections

Appendix A

MCU Memory and Memory-Mapped Registers

This section describes the TUSB3200 MCU memory configurations and operation. In general, the MCU memory operation is the same as the industry standard 8052 MCU.

A.1 MCU Memory Space

The TUSB3200 MCU memory is organized into three individual spaces: program memory, external data memory and internal data memory. The total address range for the program memory and the external data memory spaces is 64K bytes each. The total address range for the internal data memory is 256 bytes.

The read only program memory contains the instructions to be executed by the MCU. The TUSB3200 uses a 4K boot ROM as the program memory during initialization. The boot ROM program code will download the application program code from a nonvolatile memory (i.e., EEPROM) on the peripheral PCB. The application program code will be written to an 8K RAM mapped to the external data memory space. After downloading the application program code to RAM, the boot ROM will enable the normal operating mode by setting the ROM disable (SDW) bit (refer to memory configuration register) to enable program code execution from the 8K RAM instead of the boot ROM. In the normal operating mode, the boot ROM is still mapped to program memory space starting at address 8000h. Refer to Figures A-1 and A-2 for details.

The external data memory contains the data buffers for the USB endpoints, the configuration blocks for the USB endpoints, the setup data packet buffer for the USB control endpoint, and memory mapped registers. The data buffers for the USB endpoints, the configuration blocks for the USB endpoints and the setup data packet buffer for the USB control endpoint are all implemented in RAM. The memory mapped registers used for control and status registers are implemented in hardware with flip-flops. The data buffers for the USB endpoints are a total of 1832 bytes, the configuration blocks for the USB endpoints are a total of 128 bytes, the setup packet buffer for the USB control endpoint is 8 bytes and the memory mapped registers space is 80 bytes. The total external data memory space used for these blocks of memory is 2K bytes. In addition to these memory blocks, an 8K RAM is mapped to the external data memory space in the boot loader mode of operation. The 8K RAM is read/write in this mode and is used to store the application program code during download by the boot ROM. In the normal mode of operation, the 8K RAM is mapped to the program memory space and is read only.

A.2 Internal Data Memory

The internal data memory space is a total of 256 bytes of RAM, which includes the 128 bytes of special function registers (SFR) space. The internal data memory space is mapped in accordance with the industry standard 8052 MCU. The internal data memory space is mapped from 00h to FFh with the SFRs mapped from 80h to FFh. The lower 128 bytes are accessible with both direct and indirect addressing. However, the upper 128 bytes, which is the SFR space, is only accessible with direct addressing.

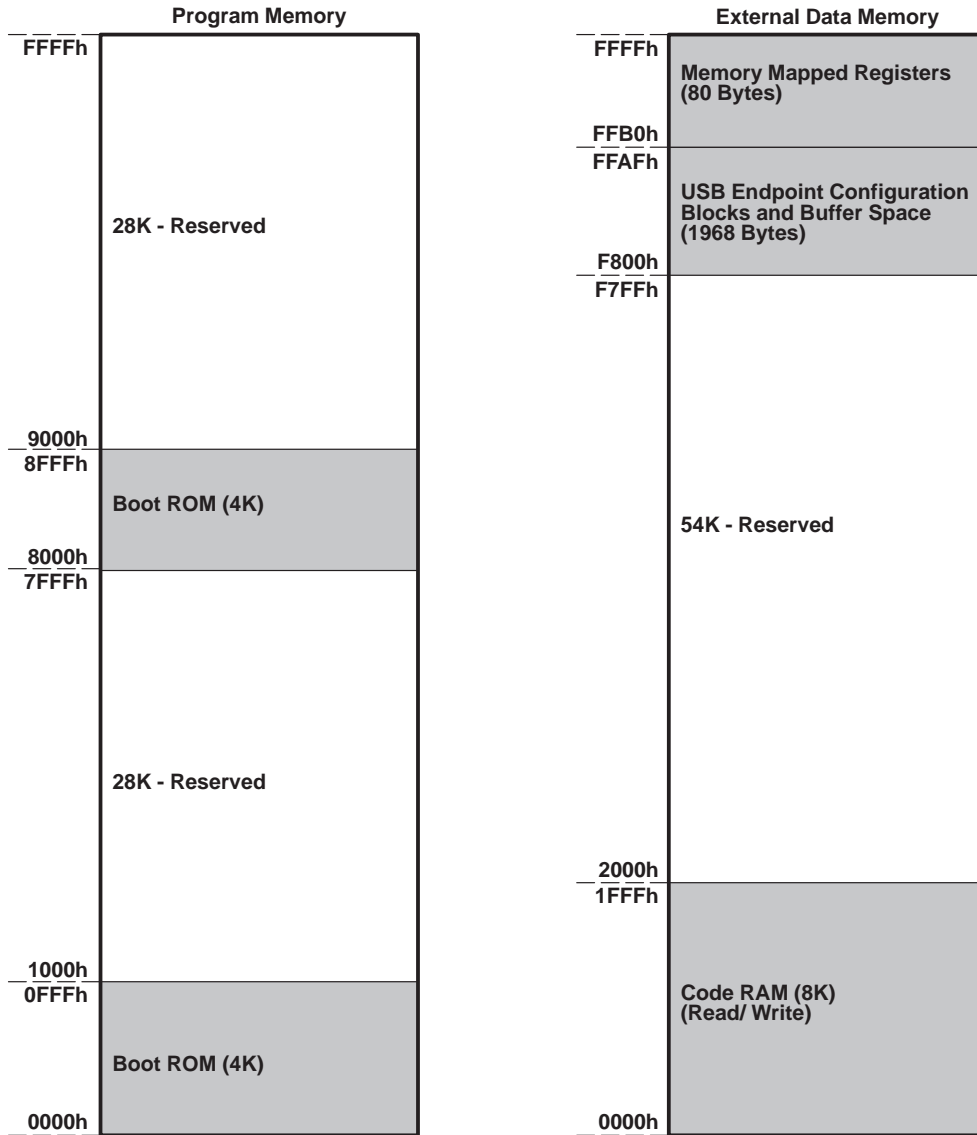

Figure A-1. Boot Loader Mode Memory Map

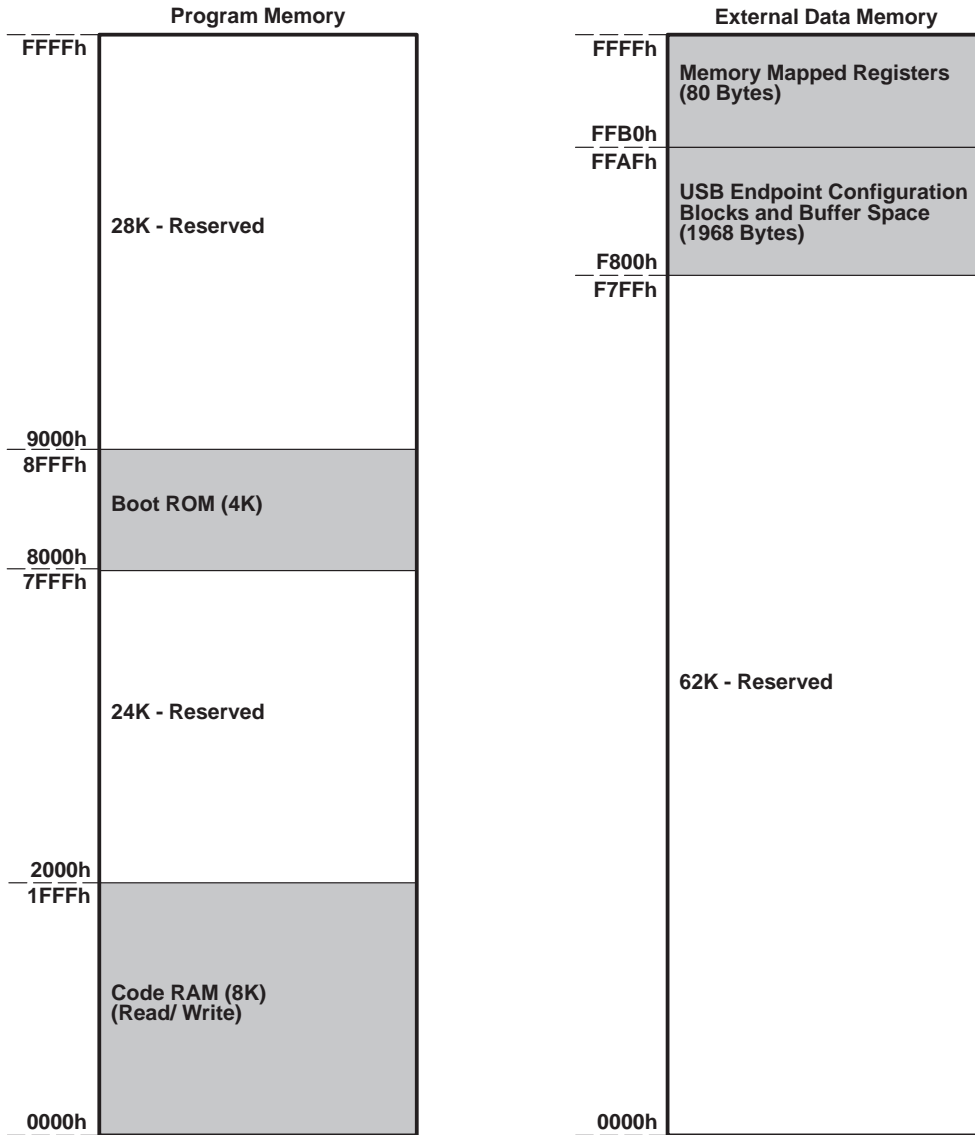

Figure A-2. Normal Operating Mode Memory Map

A.3 External MCU Mode Memory Space

When using an external MCU for firmware development, only the USB configuration blocks, the USB buffer space and the memory mapped registers are accessible by the external MCU. See Section A.4 for details. In this mode, only address lines A0 to A10 are input to the TUSB3200 device from the external MCU. Therefore, the USB buffer space and the memory mapped registers in the external data memory space are not fully decoded since all sixteen address lines are not available. Hence, the USB buffer space and the memory mapped registers are actually accessible at any 2K boundary within the total 64K external data memory space of the external MCU. As a result, when using the TUSB3200 in the external MCU mode, nothing can be mapped to the external data memory space of the external MCU except the USB buffer space and the memory mapped registers of the TUSB3200 device.

A.4 USB Endpoint Configuration Blocks and Data Buffers Space

A.4.1 USB Endpoint Configuration Blocks

The USB endpoint configuration space contains 16 blocks of 8 bytes which define configuration, buffer location, buffer size, and data count for 16 (8 input and 8 output) USB endpoints. The MCU, UBM, and DMA, all have access to these configuration blocks.

The device defines an endpoint of a USB pipe by initializing the configuration block configuration byte. It defines the location of the pipe X and Y buffers in endpoint data buffer space by writing to the X buffer base address byte and Y buffer base address byte. Base addresses are octet (8-byte) aligned. Finally, the device sets the X and Y buffer size to allocate fixed sized buffers for the pipe. Both X and Y buffer size must be greater than or equal to the USB packet size associated with the endpoint. If the buffer size is greater than the USB packet size, each buffer will independently recirculate.

A.4.2 Data Buffers Space

The endpoint data buffer space (1832 bytes) provides rate buffering between the USB and CODECs attached to the TUSB3200. Buffers are defined in this space by base address pointers and size descriptors in the USB endpoint configuration blocks. The MCU also has access to this space.

The UBM associates USB endpoints with buffers in the endpoint data buffer space by looking up configuration for an endpoint in USB endpoint configuration space. A particular DMA channel is associated with a buffer through an endpoint number in the DMA channel's control register.

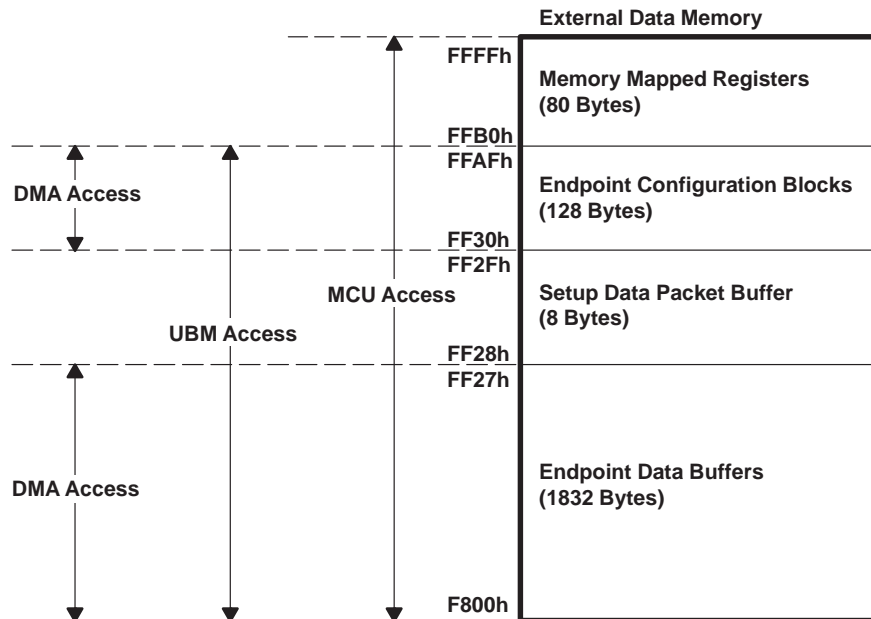

Figure A-3. USB Endpoint Configuration Blocks and Buffer Space Memory Map

Table A–1. USB Endpoint Configuration Blocks Address Map

| ADDRESS | MNEMONIC | NAME |
|---------|----------|---|
| FFAFh | OEPCNTY0 | Out endpoint 0 - Y buffer data count byte |
| FFAEh | Reserved | Reserved for future use |
| FFADh | OEPBBAY0 | Out endpoint 0 - Y buffer base address byte |
| FFACh | Reserved | Reserved for future use |
| FFABh | OEPCNTX0 | Out endpoint 0 - X buffer data count byte |
| FFAAh | OEPBSIZ0 | Out endpoint 0 - X and Y buffer size byte |
| FFA9h | OEPBBAX0 | Out endpoint 0 - X buffer base address byte |
| FFA8h | OEPCNF0 | Out endpoint 0 – configuration byte |
| FFA7h | OEPCNTY1 | Out endpoint 1 - Y buffer data count byte |
| FFA6h | Reserved | Reserved for future use |
| FFA5h | OEPBBAY1 | Out endpoint 1 - Y buffer base address byte |
| FFA4h | Reserved | Reserved for future use |
| FFA3h | OEPCNTX1 | Out endpoint 1 - X buffer data count byte |
| FFA2h | OEPBSIZ1 | Out endpoint 1 - X and Y buffer size byte |
| FFA1h | OEPBBAX1 | Out endpoint 1 - X buffer base address byte |
| FFA0h | OEPCNF1 | Out endpoint 1 – configuration byte |
| FF9Fh | OEPCNTY2 | Out endpoint 2 - Y buffer data count byte |
| FF9Eh | Reserved | Reserved for future use |
| FF9Dh | OEPBBAY2 | Out enEndpoint 2 - Y buffer base address byte |
| FF9Ch | Reserved | Reserved for future use |
| FF9Bh | OEPCNTX2 | Out endpoint 2 - X buffer data count byte |
| FF9Ah | OEPBSIZ2 | Out endpoint 2 - X and Y buffer size byte |
| FF99h | OEPBBAX2 | Out endpoint 2 - X buffer base address byte |
| FF98h | OEPCNF2 | Out endpoint 2 – configuration byte |
| FF97h | OEPCNTY3 | Out endpoint 3 - Y buffer data count byte |
| FF96h | Reserved | Reserved for future use |
| FF95h | OEPBBAY3 | Out endpoint 3 - Y buffer base address byte |
| FF94h | Reserved | Reserved for future use |
| FF93h | OEPCNTX3 | Out endpoint 3 - X buffer data count byte |
| FF92h | OEPBSIZ3 | Out endpoint 3 - X and Y buffer size byte |
| FF91h | OEPBBAX3 | Out endpoint 3 - X buffer base address byte |
| FF90h | OEPCNF3 | Out endpoint 3 – configuration byte |
| FF8Fh | OEPCNTY4 | Out endpoint 4 - Y buffer data count byte |
| FF8Eh | Reserved | Reserved for future use |
| FF8Dh | OEPBBAY4 | Out endpoint 4 - Y buffer base address byte |
| FF8Ch | Reserved | Reserved for future use |
| FF8Bh | OEPCNTX4 | Out endpoint 4 - X buffer data count byte |
| FF8Ah | OEPBSIZ4 | Out endpoint 4 - X and Y buffer size byte |
| FF89h | OEPBBAX4 | Out endpoint 4 - X buffer base address byte |
| FF88h | OEPCNF4 | Out endpoint 4 – configuration byte |
| FF87h | OEPCNTY5 | Out endpoint 5 - Y buffer data count byte |
| FF86h | Reserved | Reserved for future use |
| FF85h | OEPBBAY5 | Out endpoint 5 - Y buffer base address byte |
| FF84h | Reserved | Reserved for future use |
| FF83h | OEPCNTX5 | Out endpoint 5 - X buffer data count byte |
| FF82h | OEPBSIZ5 | Out endpoint 5 - X and Y buffer size byte |
| FF81h | OEPBBAX5 | Out endpoint 5 - X Buffer Base Address Byte |
| FF80h | OEPCNF5 | Out endpoint 5 – configuration byte |

Table A–1. USB Endpoint Configuration Blocks Address Map (Continued)

| ADDRESS | MNEMONIC | NAME |
|---------|-----------|---|
| FF7Fh | OEPDCNTY6 | Out endpoint 6 - Y buffer data count byte |
| FF7Eh | Reserved | Reserved for future use. |
| FF7Dh | OEPBBAY6 | Out endpoint 6 - Y buffer base address byte |
| FF7Ch | Reserved | Reserved for future use. |
| FF7Bh | OEPDCNTX6 | Out endpoint 6 - X buffer data count byte |
| FF7Ah | OEPBSIZ6 | Out endpoint 6 - X and Y buffer size byte |
| FF79h | OEPBBAX6 | Out endpoint 6 - X buffer base address byte |
| FF78h | OEP CNF6 | Out endpoint 6 – configuration byte |
| FF77h | OEPDCNTY7 | Out endpoint 7 - Y buffer data count byte |
| FF76h | Reserved | Reserved for future use. |
| FF75h | OEPBBAY7 | Out endpoint 7 - Y buffer base address byte |
| FF74h | Reserved | Reserved for future use. |
| FF73h | OEPDCNTX7 | Out endpoint 7 - X buffer data count byte |
| FF72h | OEPBSIZ7 | Out endpoint 7 - X and Y buffer size byte |
| FF71h | OEPBBAX7 | Out endpoint 7 - X buffer base address byte |
| FF70h | OEP CNF7 | Out endpoint 7 – configuration byte |
| FF6Fh | IEPDCNTY0 | In endpoint 0 - Y buffer data count byte |
| FF6Eh | Reserved | Reserved for future use. |
| FF6Dh | IEPBBAY0 | In endpoint 0 - Y buffer base address byte |
| FF6Ch | Reserved | Reserved for future use. |
| FF6Bh | IEPDCNTX0 | In endpoint 0 - X buffer data count byte |
| FF6Ah | IEPBSIZ0 | In endpoint 0 - X and Y buffer size byte |
| FF69h | IEPBBAX0 | In endpoint 0 - X buffer base address byte |
| FF68h | IEP CNF0 | In endpoint 0 – configuration byte |
| FF67h | IEPDCNTY1 | In endpoint 1 - Y buffer data count byte |
| FF66h | Reserved | Reserved for future use. |
| FF65h | IEPBBAY1 | In endpoint 1 - Y buffer base address byte |
| FF64h | Reserved | Reserved for future use. |
| FF63h | IEPDCNTX1 | In endpoint 1 - X buffer data count byte |
| FF62h | IEPBSIZ1 | In endpoint 1 - X and Y buffer size byte |
| FF61h | IEPBBAX1 | In endpoint 1 - X buffer base address byte |
| FF60h | IEP CNF1 | In endpoint 1 – configuration byte |
| FF5Fh | IEPDCNTY2 | In endpoint 2 - Y buffer data count byte |
| FF5Eh | Reserved | Reserved for future use. |
| FF5Dh | IEPBBAY2 | In endpoint 2 - Y buffer base address byte |
| FF5Ch | Reserved | Reserved for future use. |
| FF5Bh | IEPDCNTX2 | In endpoint 2 - X buffer data count byte |
| FF5Ah | IEPBSIZ2 | In eEndpoint 2 - X and Y buffer size byte |
| FF59h | IEPBBAX2 | In endpoint 2 - X buffer base address byte |
| FF58h | IEP CNF2 | In endpoint 2 – configuration byte |
| FF57h | IEPDCNTY3 | In endpoint 3 - Y buffer data count byte |
| FF56h | Reserved | Reserved for future use. |
| FF55h | IEPBBAY3 | In endpoint 3 - Y buffer base address byte |
| FF54h | Reserved | Reserved for future use. |
| FF53h | IEPDCNTX3 | In endpoint 3 - X buffer data count byte |
| FF52h | IEPBSIZ3 | In endpoint 3 - X and Y buffer size byte |
| FF51h | IEPBBAX3 | In endpoint 3 - X buffer base address byte |
| FF50h | IEP CNF3 | In endpoint 3 – configuration byte |

Table A-1. USB Endpoint Configuration Blocks Address Map (Continued)

| ADDRESS | MNEMONIC | NAME |
|---------|-----------|--|
| FF4Fh | IEPDCNTY4 | In endpoint 4 - Y buffer data count byte |
| FF4Eh | Reserved | Reserved for future use. |
| FF4Dh | IEPBAY4 | In endpoint 4 - Y buffer base address byte |
| FF4Ch | Reserved | Reserved for future use. |
| FF4Bh | IEPDCNTX4 | In endpoint 4 - X buffer data count byte |
| FF4Ah | IEPBSIZ4 | In endpoint 4 - X and Y buffer size byte |
| FF49h | IEPBAX4 | In endpoint 4 - X buffer base address byte |
| FF48h | IEPCNF4 | In endpoint 4 – configuration byte |
| FF47h | IEPDCNTY5 | In endpoint 5 - Y buffer data count byte |
| FF46h | Reserved | Reserved for future use. |
| FF45h | IEPBAY5 | In endpoint 5 - Y buffer base address byte |
| FF44h | Reserved | Reserved for future use. |
| FF43h | IEPDCNTX5 | In endpoint 5 - X buffer data count byte |
| FF42h | IEPBSIZ5 | In endpoint 5 - X and Y buffer size byte |
| FF41h | IEPBAX5 | In endpoint 5 - X buffer base address byte |
| FF40h | IEPCNF5 | In eEndpoint 5 – configuration byte |
| FF3Fh | IEPDCNTY6 | In endpoint 6 - Y buffer data count byte |
| FF3Eh | Reserved | Reserved for future use. |
| FF3Dh | IEPBAY6 | In endpoint 6 - Y buffer base address byte |
| FF3Ch | Reserved | Reserved for future use. |
| FF3Bh | IEPDCNTX6 | In endpoint 6 - X buffer data count byte |
| FF3Ah | IEPBSIZ6 | In endpoint 6 - X and Y buffer size byte |
| FF39h | IEPBAX6 | In endpoint 6 - X buffer base address byte |
| FF38h | IEPCNF6 | In endpoint 6 – configuration byte |
| FF37h | IEPDCNTY7 | In endpoint 7 - Y buffer data count byte |
| FF36h | Reserved | Reserved for future use. |
| FF35h | IEPBAY7 | In endpoint 7 - Y buffer base address byte |
| FF34h | Reserved | Reserved for future use. |
| FF33h | IEPDCNTX7 | In endpoint 7 - X buffer data count byte |
| FF32h | IEPBSIZ7 | In endpoint 7 - X and Y buffer size byte |
| FF31h | IEPBAX7 | In endpoint 7 - X buffer base address byte |
| FF30h | IEPCNF7 | In endpoint 7 – configuration byte |

A.4.3 USB Out Endpoint Configuration Bytes

This section describes the individual bytes in the USB endpoint configuration blocks for the out endpoints. A set of 8 bytes is used for the control and operation of each USB out endpoint. In addition to the USB control endpoint, the TUSB3200 supports up to a total of seven out endpoints.

A.4.3.1 USB Out Endpoint – Y Buffer Data Count Byte (OEPDCNTYx)

The USB out endpoint Y buffer data count byte contains the 7-bit value used to specify the amount of data received in a data packet from the host PC. The no acknowledge status bit is also contained in this byte.

| Bit | 7 | 6 | 5 | 4 | 3 | 2 | 1 | 0 |
|----------|------|--------|--------|--------|--------|--------|--------|--------|
| Mnemonic | NACK | DCNTY6 | DCNTY5 | DCNTY4 | DCNTY3 | DCNTY2 | DCNTY1 | DCNTY0 |
| Type | R/W | R/W | R/W | R/W | R/W | R/W | R/W | R/W |

| BIT | MNEMONIC | NAME | DESCRIPTION |
|-----|------------|---------------------|--|
| 7 | NACK | No acknowledge | The no acknowledge status bit is set to a 1 by the UBM at the end of a successful USB out transaction to this endpoint to indicate that the USB endpoint Y buffer contains a valid data packet and that the Y buffer data count value is valid. For control, interrupt, or bulk endpoints, when this bit is set to a 1, all subsequent transactions to the endpoint will result in a NACK handshake response to the host PC. Also for control, interrupt, and bulk endpoints, to enable this endpoint to receive another data packet from the host PC, this bit must be cleared to a 0 by the MCU. For isochronous endpoints, a NACK handshake response to the host PC is not allowed. Therefore, the UBM ignores this bit in reference to receiving the next data packet. However, the MCU or DMA should clear this bit before reading the data packet from the buffer. |
| 6:0 | DCNTY(6:0) | Y Buffer data count | The Y buffer data count value is set by the UBM when a new data packet is written to the Y buffer for the out endpoint. The 7-bit value is set to the number of bytes in the data packet for control, interrupt or bulk endpoint transfers and is set to the number of samples in the data packet for isochronous endpoint transfers. To determine the number of samples in the data packet for isochronous transfers, the bytes per sample value in the configuration byte is used. The data count value is read by the MCU or DMA to obtain the data packet size. |

A.4.3.2 USB Out Endpoint – Y Buffer Base Address Byte (OEPBBAYx)

The USB out endpoint Y buffer base address byte contains the 8-bit value used to specify the base memory location for the Y data buffer for a particular USB out endpoint.

| Bit | 7 | 6 | 5 | 4 | 3 | 2 | 1 | 0 |
|----------|--------|-------|-------|-------|-------|-------|-------|-------|
| Mnemonic | BBAY10 | BBAY9 | BBAY8 | BBAY7 | BBAY6 | BBAY5 | BBAY4 | BBAY3 |
| Type | R/W | R/W | R/W | R/W | R/W | R/W | R/W | R/W |

| BIT | MNEMONIC | NAME | DESCRIPTION |
|-----|------------|-----------------------|---|
| 7:0 | BBAY(10:3) | Y Buffer base address | The Y buffer base address value is set by the MCU to program the base address location in memory to be used for the Y data buffer. A total of 11 bits is used to specify the base address location. This byte specifies the most significant 8 bits of the address. All 0s are used by the hardware for the three least significant bits. |

A.4.3.3 USB Out Endpoint – X Buffer Data Count Byte (OEPDCNTXx)

The USB out endpoint X buffer data count byte contains the 7-bit value used to specify the amount of data received in a data packet from the host PC. The no acknowledge status bit is also contained in this byte.

| Bit | 7 | 6 | 5 | 4 | 3 | 2 | 1 | 0 |
|----------|------|--------|--------|--------|--------|--------|--------|--------|
| Mnemonic | NACK | DCNTX6 | DCNTX5 | DCNTX4 | DCNTX3 | DCNTX2 | DCNTX1 | DCNTX0 |
| Type | R/W | R/W | R/W | R/W | R/W | R/W | R/W | R/W |

| BIT | MNEMONIC | NAME | DESCRIPTION |
|-----|------------|---------------------|--|
| 7 | NACK | No acknowledge | The no acknowledge status bit is set to a 1 by the UBM at the end of a successful USB out transaction to this endpoint to indicate that the USB endpoint X buffer contains a valid data packet and that the X buffer data count value is valid. For control, interrupt, or bulk endpoints, when this bit is set to a 1, all subsequent transactions to the endpoint will result in a NACK handshake response to the host PC. Also for control, interrupt, and bulk endpoints, to enable this endpoint to receive another data packet from the host PC, this bit must be cleared to a 0 by the MCU. For isochronous endpoints, a NACK handshake response to the host PC is not allowed. Therefore, the UBM ignores this bit in reference to receiving the next data packet. However, the MCU or DMA should clear this bit before reading the data packet from the buffer. |
| 6:0 | DCNTX(6:0) | X Buffer data count | The X buffer data count value is set by the UBM when a new data packet is written to the X buffer for the out endpoint. The 7-bit value is set to the number of bytes in the data packet for control, interrupt, or bulk endpoint transfers and is set to the number of samples in the data packet for isochronous endpoint transfers. To determine the number of samples in the data packet for isochronous transfers, the bytes per sample value in the configuration byte is used. The data count value is read by the MCU or DMA to obtain the data packet size. |

A.4.3.4 USB Out Endpoint – X and Y Buffer Size Byte (OEPBSIZx)

The USB out endpoint X and Y buffer size byte contains the 8-bit value used to specify the size of the two data buffers to be used for this endpoint.

| Bit | 7 | 6 | 5 | 4 | 3 | 2 | 1 | 0 |
|----------|-------|-------|-------|-------|-------|-------|-------|-------|
| Mnemonic | BSIZ7 | BSIZ6 | BSIZ5 | BSIZ4 | BSIZ3 | BSIZ2 | BSIZ1 | BSIZ0 |
| Type | R/W | R/W | R/W | R/W | R/W | R/W | R/W | R/W |

| BIT | MNEMONIC | NAME | DESCRIPTION |
|-----|-----------|-------------|--|
| 7:0 | BSIZ(7:0) | Buffer size | The X and Y buffer size value is set by the MCU to program the size of the X and Y data packet buffers. Both buffers are programmed to the same size based on this value. This value should be in 8 byte units. For example, a value of 18h would result in the size of the X and Y buffers each being set to 192 bytes. |

A.4.3.5 USB Out Endpoint – X Buffer Base Address Byte (OEPBBAXx)

The USB out endpoint X buffer base address byte contains the 8-bit value used to specify the base memory location for the X data buffer for a particular USB out endpoint.

| Bit | 7 | 6 | 5 | 4 | 3 | 2 | 1 | 0 |
|----------|--------|-------|-------|-------|-------|-------|-------|-------|
| Mnemonic | BBAX10 | BBAX9 | BBAX8 | BBAX7 | BBAX6 | BBAX5 | BBAX4 | BBAX3 |
| Type | R/W | R/W | R/W | R/W | R/W | R/W | R/W | R/W |

| BIT | MNEMONIC | NAME | DESCRIPTION |
|-----|------------|-----------------------|---|
| 7:0 | BBAX(10:3) | X Buffer base address | The X buffer base address value is set by the MCU to program the base address location in memory to be used for the X data buffer. A total of 11 bits is used to specify the base address location. This byte specifies the most significant 8 bits of the address. All 0s are used by the hardware for the three least significant bits. |

A.4.3.6 USB Out Endpoint – Configuration Byte (OEPCNFx)

The USB out endpoint configuration byte contains the various bits used to configure and control the endpoint. Note that the bits in this byte take on different functionality based on the type of endpoint defined. Basically, the control, interrupt, and bulk endpoints function differently than the isochronous endpoints.

A.4.3.6.1 USB Out Endpoint – Control, Interrupt or Bulk configuration byte

This section defines the functionality of the bits in the USB out endpoint configuration byte for control, interrupt, and bulk endpoints.

| | | | | | | | | |
|----------|-------|-----|--------|------|-------|-------|-----|-----|
| Bit | 7 | 6 | 5 | 4 | 3 | 2 | 1 | 0 |
| Mnemonic | OEPEN | ISO | TOGGLE | DBUF | STALL | OEPIE | — | — |
| Type | R/W | R/W | R/W | R/W | R/W | R/W | R/W | R/W |

| BIT | MNEMONIC | NAME | DESCRIPTION |
|-----|----------|----------------------|--|
| 7 | OEPEN | Endpoint enable | The endpoint enable bit is set to a 1 by the MCU to enable the out endpoint. |
| 6 | ISO | Isochronous endpoint | The isochronous endpoint bit is set to a 1 by the MCU to specify the use of a particular out endpoint for isochronous transactions. This bit should be cleared to a 0 by the MCU to use a particular out endpoint for control, interrupt or bulk transactions. |
| 5 | TOGGLE | Toggle | The toggle bit is controlled by the UBM and is toggled at the end of a successful out data stage transaction if a valid data packet is received and the data packet PID matches the expected PID. |
| 4 | DBUF | Double buffer mode | The double buffer mode bit is set to a 1 by the MCU to enable the use of both the X and Y data packet buffers for USB transactions to a particular out endpoint. This bit should be cleared to a 0 by the MCU to use the single buffer mode. In the single buffer mode, only the X buffer is used. |
| 3 | STALL | Stall | The stall bit is set to a 1 by the MCU to stall endpoint transactions. When this bit is set, the hardware will automatically return a stall handshake to the host PC for any transaction received for the endpoint. An exception is the control endpoint setup stage transaction, which must always be received. This requirement allows a Clear_Feature_Stall request to be received from the host PC. Control endpoint data and status stage transactions however can be stalled. The stall bit is cleared to a 0 by the MCU if a Clear_Feature_Stall request or a USB reset is received from the host PC. For a control write transaction, if the amount of data received is greater than expected, the UBM will set the stall bit to a 1 to stall the endpoint. When the stall bit is set to a 1 by the UBM, the USB out endpoint 0 interrupt will be generated. |
| 2 | OEPIE | Interrupt enable | The interrupt enable bit is set to a 1 by the MCU to enable the out endpoint interrupt. See section A.5.7.1 for details on the out endpoint interrupts. |
| 1:0 | — | Reserved | Reserved for future use |

A.4.3.6.2 USB Out Endpoint – Isochronous Configuration Byte

This section defines the functionality of the bits in the USB out endpoint configuration byte for isochronous endpoints.

| Bit | 7 | 6 | 5 | 4 | 3 | 2 | 1 | 0 |
|----------|-------|-----|-----|------|------|------|------|------|
| Mnemonic | OEPEN | ISO | OVF | BPS4 | BPS3 | BPS2 | BPS1 | BPS0 |
| Type | R/W | R/W | R/W | R/W | R/W | R/W | R/W | R/W |

| BIT | MNEMONIC | NAME | DESCRIPTION |
|-----|----------|----------------------|---|
| 7 | OEPEN | Endpoint enable | The endpoint enable bit is set to a 1 by the MCU to enable the out endpoint. |
| 6 | ISO | Isochronous endpoint | The isochronous endpoint bit is set to a 1 by the MCU to specify the use of a particular out endpoint for isochronous transactions. This bit should be cleared to a 0 by the MCU for a particular out endpoint to be used for control, interrupt, or bulk transactions. |
| 5 | OVF | Overflow | The overflow bit is set to a 1 by the UBM to indicate a buffer overflow condition has occurred. This bit is used for diagnostic purposes only and is not used for normal operation. This bit can only be cleared to a 0 by the MCU. |
| 4:0 | BPS(4:0) | Bytes per sample | The bytes per sample bits are used to define the number of bytes per isochronous data sample. In other words, the total number of bytes in an entire audio CODEC frame. For example, a PCM 16-bit stereo audio data sample consists of 4 bytes. There are two bytes of left channel data and two bytes of right channel data. For a four channel system using 16-bit data, the total number of bytes would be 8, which would be the isochronous data sample size. 00h = 1 byte, 01h = 2 bytes, ..., 1Fh = 32 bytes |

A.4.4 USB In Endpoint Configuration Bytes

This section describes the individual bytes in the USB endpoint configuration blocks for the in endpoints. A set of 8 bytes is used for the control and operation of each USB in endpoint. In addition to the USB control endpoint, the TUSB3200 supports up to a total of seven in endpoints.

A.4.4.1 USB In Endpoint – Y Buffer Data Count Byte (IEPDCNTYx)

The USB in endpoint Y buffer data count byte contains the 7-bit value used to specify the amount of data to be transmitted in a data packet to the host PC. The no acknowledge status bit is also contained in this byte.

| Bit | 7 | 6 | 5 | 4 | 3 | 2 | 1 | 0 |
|----------|------|--------|--------|--------|--------|--------|--------|--------|
| Mnemonic | NACK | DCNTY6 | DCNTY5 | DCNTY4 | DCNTY3 | DCNTY2 | DCNTY1 | DCNTY0 |
| Type | R/W | R/W | R/W | R/W | R/W | R/W | R/W | R/W |

| BIT | MNEMONIC | NAME | DESCRIPTION |
|-----|------------|---------------------|---|
| 7 | NACK | No acknowledge | The no acknowledge status bit is set to a 1 by the UBM at the end of a successful USB in transaction to this endpoint to indicate that the USB endpoint Y buffer is empty. For control, interrupt, or bulk endpoints, when this bit is set to a 1, all subsequent transactions to the endpoint will result in a NACK handshake response to the host PC. Also for control, interrupt, and bulk endpoints, to enable this endpoint to transmit another data packet to the Host PC, this bit must be cleared to a 0 by the MCU. For isochronous endpoints, a NACK handshake response to the host PC is not allowed. Therefore, the UBM ignores this bit in reference to sending the next data packet. However, the MCU or DMA should clear this bit after writing a data packet to the buffer. |
| 6:0 | DCNTY(6:0) | Y Buffer data count | The Y buffer data count value is set by the MCU or DMA when a new data packet is written to the Y buffer for the in endpoint. The 7-bit value is set to the number of bytes in the data packet for control, interrupt, or bulk endpoint transfers and is set to the number of samples in the data packet for isochronous endpoint transfers. To determine the number of samples in the data packet for isochronous transfers, the bytes per sample value in the configuration byte is used. |

A.4.4.2 USB In Endpoint – Y Buffer Base Address Byte (IEPBAYx)

The USB in endpoint Y buffer base address byte contains the 8-bit value used to specify the base memory location for the Y data buffer for a particular USB in endpoint.

| Bit | 7 | 6 | 5 | 4 | 3 | 2 | 1 | 0 |
|----------|--------|-------|-------|-------|-------|-------|-------|-------|
| Mnemonic | BBAY10 | BBAY9 | BBAY8 | BBAY7 | BBAY6 | BBAY5 | BBAY4 | BBAY3 |
| Type | R/W | R/W | R/W | R/W | R/W | R/W | R/W | R/W |

| BIT | MNEMONIC | NAME | DESCRIPTION |
|-----|------------|-----------------------|---|
| 7:0 | BBAY(10:3) | Y Buffer base address | The Y buffer base address value is set by the MCU to program the base address location in memory to be used for the Y data buffer. A total of 11 bits is used to specify the base address location. This byte specifies the most significant 8 bits of the address. All 0s are used by the hardware for the three least significant bits. |

A.4.4.3 USB In Endpoint – X Buffer Data Count Byte (IEPDCNTXx)

The USB in endpoint X buffer data count byte contains the 7-bit value used to specify the amount of data received in a data packet from the host PC. The no acknowledge status bit is also contained in this byte.

| Bit | 7 | 6 | 5 | 4 | 3 | 2 | 1 | 0 |
|----------|------|--------|--------|--------|--------|--------|--------|--------|
| Mnemonic | NACK | DCNTX6 | DCNTX5 | DCNTX4 | DCNTX3 | DCNTX2 | DCNTX1 | DCNTX0 |
| Type | R/W | R/W | R/W | R/W | R/W | R/W | R/W | R/W |

| BIT | MNEMONIC | NAME | DESCRIPTION |
|-----|------------|---------------------|---|
| 7 | NACK | No acknowledge | The no acknowledge status bit is set to a 1 by the UBM at the end of a successful USB in transaction to this endpoint to indicate that the USB endpoint X buffer is empty. For control, interrupt, or bulk endpoints, when this bit is set to a 1, all subsequent transactions to the endpoint will result in a NACK handshake response to the host PC. Also for control, interrupt, and bulk endpoints, to enable this endpoint to transmit another data packet to the host PC, this bit must be cleared to a 0 by the MCU. For isochronous endpoints, a NACK handshake response to the host PC is not allowed. Therefore, the UBM ignores this bit in reference to sending the next data packet. However, the MCU or DMA should clear this bit after writing a data packet to the buffer. |
| 6:0 | DCNTX(6:0) | X Buffer data count | The X buffer data count value is set by the MCU or DMA when a new data packet is written to the X buffer for the in endpoint. The 7-bit value is set to the number of bytes in the data packet for control, interrupt, or bulk endpoint transfers and is set to the number of samples in the data packet for isochronous endpoint transfers. To determine the number of samples in the data packet for isochronous transfers, the bytes per sample value in the configuration byte is used. |

A.4.4.4 USB In Endpoint – X and Y Buffer Size Byte (IEPBSIZx)

The USB in endpoint X and Y buffer size byte contains the 8-bit value used to specify the size of the two data buffers to be used for this endpoint.

| Bit | 7 | 6 | 5 | 4 | 3 | 2 | 1 | 0 |
|----------|-------|-------|-------|-------|-------|-------|-------|-------|
| Mnemonic | BSIZ7 | BSIZ6 | BSIZ5 | BSIZ4 | BSIZ3 | BSIZ2 | BSIZ1 | BSIZ0 |
| Type | R/W | R/W | R/W | R/W | R/W | R/W | R/W | R/W |

| BIT | MNEMONIC | NAME | DESCRIPTION |
|-----|-----------|-------------|--|
| 7 | BSIZ(7:0) | Buffer size | The X and Y buffer size value is set by the MCU to program the size of the X and Y data packet buffers. Both buffers are programmed to the same size based on this value. This value should be in 8 byte units. For example, a value of 18h would result in the size of the X and Y buffers each being set to 192 bytes. |

A.4.4.5 USB In Endpoint – X Buffer Base Address Byte (IEPBAXx)

The USB in endpoint X buffer base address byte contains the 8-bit value used to specify the base memory location for the X data buffer for a particular USB in endpoint.

| Bit | 7 | 6 | 5 | 4 | 3 | 2 | 1 | 0 |
|----------|--------|-------|-------|-------|-------|-------|-------|-------|
| Mnemonic | BBAX10 | BBAX9 | BBAX8 | BBAX7 | BBAX6 | BBAX5 | BBAX4 | BBAX3 |
| Type | R/W | R/W | R/W | R/W | R/W | R/W | R/W | R/W |

| BIT | MNEMONIC | NAME | DESCRIPTION |
|-----|------------|-----------------------|---|
| 7:0 | BBAX(10:3) | X Buffer base address | The X buffer base address value is set by the MCU to program the base address location in memory to be used for the X data buffer. A total of 11 bits is used to specify the base address location. This byte specifies the most significant 8 bits of the address. All 0s are used by the hardware for the three least significant bits. |

A.4.4.6 USB In Endpoint – Configuration Byte (IEPCNFx)

The USB in endpoint configuration byte contains the various bits used to configure and control the endpoint. Note that the bits in this byte take on different functionality based on the type of endpoint defined. Basically, the control, interrupt and bulk endpoints function differently than the isochronous endpoints.

A.4.4.6.1 USB In Endpoint – Control, Interrupt or Bulk Configuration Byte

This section defines the functionality of the bits in the USB in endpoint configuration byte for control, interrupt, and bulk endpoints.

| Bit | 7 | 6 | 5 | 4 | 3 | 2 | 1 | 0 |
|----------|-------|-----|--------|------|-------|-------|-----|-----|
| Mnemonic | IEPEN | ISO | TOGGLE | DBUF | STALL | IEPIE | — | — |
| Type | R/W | R/W | R/W | R/W | R/W | R/W | R/W | R/W |

| BIT | MNEMONIC | NAME | DESCRIPTION |
|-----|----------|----------------------|---|
| 7 | IEPEN | Endpoint enable | The endpoint enable bit is set to a 1 by the MCU to enable the in endpoint. This bit does not affect the reception of the control endpoint setup stage transaction. |
| 6 | ISO | Isochronous endpoint | The isochronous endpoint bit is set to a 1 by the MCU to specify the use of a particular in endpoint for isochronous transactions. This bit should be cleared to a 0 by the MCU to use a particular in endpoint for control, interrupt, or bulk transactions. |
| 5 | TOGGLE | Toggle | The toggle bit is controlled by the UBM and is toggled at the end of a successful in data stage transaction if a valid data packet is transmitted. If this bit is a 0, a DATA0 PID is transmitted in the data packet to the host PC. If this bit is a 1, a DATA1 PID is transmitted in the data packet. |
| 4 | DBUF | Double buffer mode | The double buffer mode bit is set to a 1 by the MCU to enable the use of both the X and Y data packet buffers for USB transactions to a particular in endpoint. This bit should be cleared to a 0 by the MCU to use the single buffer mode. In the single buffer mode, only the X buffer is used. |
| 3 | STALL | Stall | The stall bit is set to a 1 by the MCU to stall endpoint transactions. When this bit is set, the hardware will automatically return a stall handshake to the host PC for any transaction received for the endpoint. |
| 2 | IEPIE | Interrupt enable | The interrupt enable bit is set to a 1 by the MCU to enable the in endpoint interrupt. See section A.5.7.2 for details on the in endpoint interrupts. |
| 1:0 | — | Reserved | Reserved for future use |

A.4.4.6.2 USB In Endpoint – Isochronous Configuration Byte

This section defines the functionality of the bits in the USB in endpoint configuration byte for isochronous endpoints.

| | | | | | | | | |
|----------|-------|-----|-----|------|------|------|------|------|
| Bit | 7 | 6 | 5 | 4 | 3 | 2 | 1 | 0 |
| Mnemonic | IEPEN | ISO | OVF | BPS4 | BPS3 | BPS2 | BPS1 | BPS0 |
| Type | R/W | R/W | R/W | R/W | R/W | R/W | R/W | R/W |

| BIT | MNEMONIC | NAME | DESCRIPTION |
|-----|----------|----------------------|---|
| 7 | IEPEN | Endpoint enable | The endpoint enable bit is set to a 1 by the MCU to enable the in endpoint. |
| 6 | ISO | Isochronous endpoint | The isochronous endpoint bit is set to a 1 by the MCU to specify the use of a particular in endpoint for isochronous transactions. This bit should be cleared to a 0 by the MCU for a particular in endpoint to be used for control, interrupt, or bulk transactions. |
| 5 | OVF | Overflow | The overflow bit is set to a 1 by the UBM to indicate a buffer overflow condition has occurred. This bit is used for diagnostic purposes only and is not used for normal operation. This bit can only be cleared to a 0 by the MCU. |
| 4:0 | BPS(4:0) | Bytes per sample | The bytes per sample bits are used to define the number of bytes per isochronous data sample. In other words, the total number of bytes in an entire audio CODEC frame. For example, a PCM 16-bit stereo audio data sample consists of 4 bytes. There are two bytes of left channel data and two bytes of right channel data. For a four channel system using 16-bit data, the total number of bytes would be 8, which would be the isochronous data sample size. 00h = 1 byte, 01h = 2 bytes, ..., 1Fh = 32 bytes |

A.4.5 USB Control Endpoint Setup Stage Data Packet Buffer

The USB control endpoint setup stage data packet buffer is the buffer space used to store the 8-byte data packet received from the host PC during a control endpoint transfer setup stage transaction. Refer to Chapter 9 of the USB Specification for details on the data packet.

Table A–2. USB Control Endpoint Setup Data Packet Buffer Address Map

| ADDRESS | NAME |
|---------|--|
| FF2Fh | wLength – Number of bytes to transfer in the data stage. |
| FF2Eh | wLength – Number of bytes to transfer in the data stage. |
| FF2Dh | wIndex – Index or offset value. |
| FF2Ch | wIndex – Index or offset value. |
| FF2Bh | wValue – Value of a parameter specific to the request. |
| FF2Ah | wValue – Value of a parameter specific to the request. |
| FF29h | bRequest – Specifies the particular request. |
| FF28h | bmRequestType – Identifies the characteristics of the request. |

A.5 Memory-Mapped Registers

The TUSB3200 device provides a set of control and status registers to be used by the MCU to control the overall operation of the device. This section describes the memory-mapped registers.

Table A–3. Memory Mapped Registers Address Map

| ADDRESS | MNEMONIC | NAME |
|---------|----------|--|
| FFFFh | USBFADR | USB function address register |
| FFFEh | USBSTA | USB status register |
| FFFDh | USBIMSK | USB interrupt mask register |
| FFFC | USBCTL | USB control register |
| FFFBh | USBFNL | USB frame number register (low byte) |
| FFFAh | USBFNH | USB frame number register (high byte) |
| FFF9h | DMATSL3 | DMA channel 3 time slot assignment register (low byte) |
| FFF8h | DMATSH3 | DMA channel 3 time slot assignment register (high byte) |
| FFF7h | DMACTL3 | DMA channel 3 control register |
| FFF6h | DMATSL2 | DMA channel 2 time slot assignment register (low byte) |
| FFF5h | DMATSH2 | DMA channel 2 time slot assignment register (high byte) |
| FFF4h | DMACTL2 | DMA channel 2 control register |
| FFF3h | Reserved | Reserved for future use |
| FFF2h | Reserved | Reserved for future use |
| FFF1h | Reserved | Reserved for future use |
| FFF0h | DMATSL1 | DMA channel 1 time slot assignment register (low byte) |
| FFEFh | DMATSH1 | DMA channel 1 time slot assignment register (high byte) |
| FFEEh | DMACTL1 | DMA channel 1 control register |
| FFEDh | Reserved | Reserved for future use |
| FFECh | Reserved | Reserved for future use |
| FFEBh | Reserved | Reserved for future use |
| FFEAh | DMATSL0 | DMA channel 0 time slot assignment register (low byte) |
| FFE9h | DMATSH0 | DMA Channel 0 time slot assignment register (high byte) |
| FFE8h | DMACTL0 | DMA channel 0 control register |
| FFE7h | ACGFRQ0 | Adaptive clock generator frequency register (byte 0) |
| FFE6h | ACGFRQ1 | Adaptive clock generator frequency register (byte 1) |
| FFE5h | ACGFRQ2 | Adaptive clock generator frequency register (byte 2) |
| FFE4h | ACGCAPL | Adaptive clock generator mclk capture register (low byte) |
| FFE3h | ACGCAPH | Adaptive clock generator mclk capture register (high byte) |
| FFE2h | ACGDCTL | Adaptive clock generator divider control register |
| FFE1h | ACGCTL | Adaptive clock generator control register |
| FFE0h | CPTCNF1 | CODEC port interface configuration register 1 |
| FFDFh | CPTCNF2 | CODEC port interface configuration register 2 |
| FFDEh | CPTCNF3 | CODEC port interface configuration register 3 |
| FFDDh | CPTCNF4 | CODEC port interface configuration register 4 |
| FFDC | CPTCTL | CODEC port interface control and status register |
| FFDBh | CPTADR | CODEC port interface address register |
| FFDAh | CPTDATH | CODEC port interface data register (low byte) |
| FFD9h | CPTDATH | CODEC port interface data register (high byte) |
| FFD8h | CPTVSLH | CODEC port interface valid slots register (low byte) |
| FFD7h | CPTVSLH | CODEC port interface valid slots register (high byte) |

Table A-3. Memory-Mapped Registers Address Map (Continued)

| ADDRESS | MNEMONIC | NAME |
|---------|----------|--|
| FFD6h | Reserved | Reserved for future use |
| FFD5h | Reserved | Reserved for future use |
| FFD4h | Reserved | Reserved for future use |
| FFD3h | Reserved | Reserved for future use |
| FFD2h | Reserved | Reserved for future use |
| FFD1h | Reserved | Reserved for future use |
| FFD0h | Reserved | Reserved for future use |
| FFCFh | Reserved | Reserved for future use |
| FFCEh | Reserved | Reserved for future use |
| FFCDh | Reserved | Reserved for future use |
| FFCCh | Reserved | Reserved for future use |
| FFCBh | Reserved | Reserved for future use |
| FFCAh | Reserved | Reserved for future use |
| FFC9h | Reserved | Reserved for future use |
| FFC8h | Reserved | Reserved for future use |
| FFC7h | Reserved | Reserved for future use |
| FFC6h | Reserved | Reserved for future use |
| FFC5h | Reserved | Reserved for future use |
| FFC4h | Reserved | Reserved for future use |
| FFC3h | I2CADR | I ² C interface address register |
| FFC2h | I2CDATI | I ² C interface receive data register |
| FFC1h | I2CDATO | I ² C Interface Transmit Data Register |
| FFC0h | I2CCTL | I ² C interface control and status register |
| FFBFh | PWMFRQ | PWM frequency register |
| FFBEh | PWMPWL | PWM pulse width register (low byte) |
| FFBDh | PWMPWH | PWM pulse width register (high byte) |
| FFBCh | Reserved | Reserved for future use |
| FFBBh | Reserved | Reserved for future use |
| FFBAh | Reserved | Reserved for future use |
| FFB9h | Reserved | Reserved for future use |
| FFB8h | Reserved | Reserved for future use |
| FFB7h | Reserved | Reserved for future use |
| FFB6h | Reserved | Reserved for future use |
| FFB5h | Reserved | Reserved for future use |
| FFB4h | OEPINT | USB out endpoint interrupt register |
| FFB3h | IEPINT | USB in endpoint interrupt register |
| FFB2h | VECINT | Interrupt vector register |
| FFB1h | GLOBCTL | Global control register |
| FFB0h | MEMCFG | Memory configuration register |

A.5.1 USB Registers

This section describes the memory-mapped registers used for control and operation of the USB functions. This section consists of 6 registers used for USB functions.

A.5.1.1 USB Function Address Register (USBFADR – Address FFFFh)

The USB function address register contains the current setting of the USB device address assigned to the function by the host. After power-on reset or USB reset, the default address will be 00h. During enumeration of the function by the host, the MCU should load the assigned address to this register when a USB Set_Address request is received by the control endpoint.

| | | | | | | | | |
|-----------------|----------|----------|----------|----------|----------|----------|----------|----------|
| Bit | 7 | 6 | 5 | 4 | 3 | 2 | 1 | 0 |
| Mnemonic | — | FA6 | FA5 | FA4 | FA3 | FA2 | FA1 | FA0 |
| Type | R | R/W | R/W | R/W | R/W | R/W | R/W | R/W |
| Default | 0 | 0 | 0 | 0 | 0 | 0 | 0 | 0 |

| BIT | MNEMONIC | NAME | DESCRIPTION |
|-----|----------|------------------|---|
| 7 | — | Reserved | Reserved for future use |
| 6:0 | FA(6:0) | Function address | The function address bit values are set by the MCU to program the USB device address assigned by the host PC. |

A.5.1.2 USB Status Register (USBSTA – Address FFFEh)

The USB status register contains various status bits used for USB operations.

| Bit | 7 | 6 | 5 | 4 | 3 | 2 | 1 | 0 |
|----------|------|------|------|-----|------|-------|---|-------|
| Mnemonic | RSTR | SUSR | RESR | SOF | PSOF | SETUP | — | STPOW |
| Type | R | R | R | R | R | R | R | R |
| Default | 0 | 0 | 0 | 0 | 0 | 0 | 0 | 0 |

| BIT | MNEMONIC | NAME | DESCRIPTION |
|-----|----------|------------------------------------|---|
| 7 | RSTR | Function reset | The function reset bit is set to a 1 by hardware in response to the host PC initiating a USB reset to the function. When a USB reset occurs, all of the USB logic blocks, including the SIE, UBM, frame timer, and suspend/resume are automatically reset. The function reset enable (FRSTE) control bit in the USB control register can be used to enable the USB reset to reset all TUSB3200 logic, except the shadow the ROM (SDW) and the USB function connect (CONT) bits. When the FRSTE control bit is set to a 1, the reset output (RSTO) signal from the TUSB3200 device will also be active when a USB reset occurs. This bit is read only and is cleared when the MCU writes to the interrupt vector register. |
| 6 | SUSR | Function suspend | The function suspend bit is set to a 1 by hardware when a USB suspend condition is detected by the suspend/resume logic. See eection 2.2.5 for details on the USB suspend and resume operation. This bit is read only and is cleared when the MCU writes to the interrupt vector register. |
| 5 | RESR | Function resume | The function resume bit is set to a 1 by hardware when a USB resume condition is detected by the suspend/resume logic. See section 2.2.5 for details on the USB suspend and resume operation. This bit is read only and is cleared when the MCU writes to the interrupt vector register. |
| 4 | SOF | Start-of-frame | The start-of-frame bit is set to a 1 by hardware when a new USB frame starts. This bit is set when the SOF packet from the host PC is detected, even if the TUSB3200 frame timer is not locked to the host PC frame timer. This bit is read only and is cleared when the MCU writes to the interrupt vector register. The nominal SOF rate is 1 ms. |
| 3 | PSOF | Pseudo start-of-frame | The pseudo start-of-frame bit is set to a 1 by hardware when a USB pseudo SOF occurs. The pseudo SOF is an artificial SOF signal that is generated when the TUSB3200 frame timer is not locked to the host PC frame timer. This bit is read only and is cleared when the MCU writes to the interrupt vector register. The nominal pseudo SOF rate is 1 ms. |
| 2 | SETUP | Setup stage transaction | The setup stage transaction bit is set to a 1 by hardware when a successful control endpoint setup stage transaction is completed. Upon completion of the setup stage transaction, the USB control endpoint setup stage data packet buffer should contain a new setup stage data packet. |
| 1 | — | Reserved | Reserved for future use |
| 0 | STPOW | Setup stage transaction over-write | The setup stage transaction over-write bit is set to a 1 by hardware when the data in the USB control endpoint setup data packet buffer is over-written. This scenario occurs when the host PC prematurely terminates a USB control transfer by simply starting a new control transfer with a new setup stage transaction. |

A.5.1.3 USB Interrupt Mask Register (USBMSK – Address FFFDh)

The USB interrupt mask register contains the interrupt mask bits used to enable or disable the generation of interrupts based on the corresponding status bits.

| Bit | 7 | 6 | 5 | 4 | 3 | 2 | 1 | 0 |
|----------|------|------|------|-----|------|-------|---|-------|
| Mnemonic | RSTR | SUSR | RESR | SOF | PSOF | SETUP | — | STPOW |
| Type | R/W | R/W | R/W | R/W | R/W | R/W | R | R/W |
| Default | 0 | 0 | 0 | 0 | 0 | 0 | 0 | 0 |

| BIT | MNEMONIC | NAME | DESCRIPTION |
|-----|----------|------------------------------------|--|
| 7 | RSTR | Function reset | The function reset interrupt mask bit is set to a 1 by the MCU to enable the USB function reset interrupt. |
| 6 | SUSR | Function suspend | The function suspend interrupt mask bit is set to a 1 by the MCU to enable the USB function suspend interrupt. |
| 5 | RESR | Function resume | The function resume interrupt mask bit is set to a 1 by the MCU to enable the USB function resume interrupt. |
| 4 | SOF | Start-of-frame | The start-of-frame interrupt mask bit is set to a 1 by the MCU to enable the USB start-of-frame interrupt. |
| 3 | PSOF | Pseudo start-of-frame | The pseudo start-of-frame interrupt mask bit is set to a 1 by the MCU to enable the USB pseudo start-of-frame interrupt. |
| 2 | SETUP | Setup stage transaction | The setup stage transaction interrupt mask bit is set to a 1 by the MCU to enable the USB setup stage transaction interrupt. |
| 1 | — | Reserved | Reserved for future use |
| 0 | STPOW | Setup stage transaction over-write | The setup stage transaction over-write interrupt mask bit is set to a 1 by the MCU to enable the USB setup stage transaction over-write interrupt. |

A.5.1.4 USB Control Register (USBCTL – Address FFFCh)

The USB control register contains various control bits used for USB operations.

| Bit | 7 | 6 | 5 | 4 | 3 | 2 | 1 | 0 |
|----------|------|-----|------|-------|---|---|---|---|
| Mnemonic | CONT | FEN | RWUP | FRSTE | — | — | — | — |
| Type | R/W | R/W | R/W | R/W | R | R | R | R |
| Default | 0 | 0 | 0 | 0 | 0 | 0 | 0 | 0 |

| BIT | MNEMONIC | NAME | DESCRIPTION |
|-----|----------|-----------------------|---|
| 7 | CONT | Function connect | The function connect bit is set to a 1 by the MCU to connect the TUSB3200 device to the USB. As a result of connecting to the USB, the host PC should enumerate the function. When this bit is set, the USB data plus pullup resistor (PUR) output signal is enabled, which will connect the pullup on the PCB to the TUSB3200 3.3-V supply voltage. When this bit is cleared to a 0, the PUR output is in the 3-state mode. This bit is not affected by a USB reset. |
| 6 | FEN | Function enable | The function enable bit is set to a 1 by the MCU to enable the TUSB3200 device to respond to USB transactions. If this bit is cleared to a 0, the UBM will ignore all USB transactions. This bit is cleared by a USB reset. |
| 5 | RWUP | Remote wake-up | The remote wake-up bit is set to a 1 by the MCU to request the suspend/resume logic to generate resume signaling upstream on the USB. This bit is used to exit a USB low-power suspend state when a remote wake-up event occurs. After initiating the resume signaling by setting this bit, the MCU should clear this bit within 2.5 μ s. |
| 4 | FRSTE | Function reset enable | The function reset enable bit is set to a 1 by the MCU to enable the USB reset to reset all internal logic including the MCU. However, the shadow the ROM (SDW) and the USB function connect (CONT) bits will not be reset. When this bit is set, the reset output ($\overline{\text{RSTO}}$) signal from the TUSB3200 device will also be active when a USB reset occurs. This bit is not affected by USB reset. |
| 3:0 | — | Reserved | Reserved for future use |

A.5.1.5 USB Frame Number Register (Low Byte) (USBFNL – Address FFFBh)

The USB frame number register (low byte) contains the least significant byte of the 11-bit frame number value received from the host PC in the start-of-frame packet.

| | | | | | | | | |
|----------|-----|-----|-----|-----|-----|-----|-----|-----|
| Bit | 7 | 6 | 5 | 4 | 3 | 2 | 1 | 0 |
| Mnemonic | FN7 | FN6 | FN5 | FN4 | FN3 | FN2 | FN1 | FN0 |
| Type | R | R | R | R | R | R | R | R |
| Default | 0 | 0 | 0 | 0 | 0 | 0 | 0 | 0 |

| BIT | MNEMONIC | NAME | DESCRIPTION |
|-----|----------|--------------|---|
| 7:0 | FN(7:0) | Frame number | The frame number bit values are updated by hardware each USB frame with the frame number field value received in the USB start-of-frame packet. The frame number can be used as a time stamp by the USB function. If the TUSB3200 frame timer is not locked to the host PC frame timer, then the frame number is incremented from the previous value when a pseudo start-of-frame occurs. |

A.5.1.6 USB Frame Number Register (High Byte) (USBFNH – Address FFFAh)

The USB frame number register (high byte) contains the most significant 3 bits of the 11-bit frame number value received from the host PC in the start-of-frame packet.

| | | | | | | | | |
|----------|---|---|---|---|---|------|-----|-----|
| Bit | 7 | 6 | 5 | 4 | 3 | 2 | 1 | 0 |
| Mnemonic | — | — | — | — | — | FN10 | FN9 | FN8 |
| Type | R | R | R | R | R | R | R | R |
| Default | 0 | 0 | 0 | 0 | 0 | 0 | 0 | 0 |

| BIT | MNEMONIC | NAME | DESCRIPTION |
|-----|----------|--------------|---|
| 7:3 | — | Reserved | Reserved for future use. |
| 2:0 | FN(10:8) | Frame number | The frame number bit values are updated by hardware each USB frame with the frame number field value received in the USB start-of-frame packet. The frame number can be used as a time stamp by the USB function. If the TUSB3200 frame timer is not locked to the host PC frame timer, then the frame number is incremented from the previous value when a pseudo start-of-frame occurs. |

A.5.2 DMA Registers

This section describes the memory-mapped registers used for the four DMA channels. Each DMA channel has a set of three registers.

A.5.2.1 DMA Channel 3 Time Slot Assignment Register (Low Byte) (DMATSL3 – Address FFF9h)

The DMA channel 3 time slot assignment register (low byte) contains the eight least significant time slot bits. The time slot assignment bits are used to define which CODEC port interface time slots are supported by DMA channel 3. The DMA channel will control the transfer of data between the USB endpoint buffers and the CODEC port interface registers based on which bits are set. The direction of the data transfer depends on the value of the USB endpoint direction bit (**EPDIR**) in the DMA channel 3 control register. The desired time slot bits should be set by the MCU before the DMA channel is enabled. There are a total of fourteen time slot bits for each DMA channel.

| | | | | | | | | |
|----------|------|------|------|------|------|------|------|------|
| Bit | 7 | 6 | 5 | 4 | 3 | 2 | 1 | 0 |
| Mnemonic | TSL7 | TSL6 | TSL5 | TSL4 | TSL3 | TSL2 | TSL1 | TSL0 |
| Type | R/W | R/W | R/W | R/W | R/W | R/W | R/W | R/W |
| Default | 0 | 0 | 0 | 0 | 0 | 0 | 0 | 0 |

| BIT | MNEMONIC | NAME | DESCRIPTION |
|-----|----------|----------------------|--|
| 7:0 | TSL(7:0) | Time slot assignment | The DMA time slot assignment bits are set to a 1 by the MCU to define the CODEC port interface time slots supported by this DMA channel. |

A.5.2.2 DMA Channel 3 Time Slot Assignment Register (High Byte) (DMATSH3 – Address FFF8h)

The DMA channel 3 time slot assignment register (high byte) contains the six most significant time slot bits. In addition, this register contains the bytes per time slot control bits.

| Bit | 7 | 6 | 5 | 4 | 3 | 2 | 1 | 0 |
|----------|-------|-------|-------|-------|-------|-------|------|------|
| Mnemonic | BPTS1 | BPTS0 | TSL13 | TSL12 | TSL11 | TSL10 | TSL9 | TSL8 |
| Type | R/W | R/W | R/W | R/W | R/W | R/W | R/W | R/W |
| Default | 0 | 0 | 0 | 0 | 0 | 0 | 0 | 0 |

| BIT | MNEMONIC | NAME | DESCRIPTION |
|-----|-----------|----------------------|--|
| 7:6 | BPTS(1:0) | Bytes per time slot | The bytes per time slot bits are used to define the number of bytes to be transferred for each time slot supported by this DMA channel. 00b = 1 byte, 01b = 2 bytes, 10b = 3 bytes, 11b = 4 bytes |
| 5:0 | TSL(13:8) | Time slot assignment | The DMA time slot assignment bits are set to a 1 by the MCU to define the CODEC port interface time slots supported by this DMA channel. |

A.5.2.3 DMA Channel 3 Control Register (DMACTL3 – Address FFF7h)

The DMA channel 3 control register is used to store various control bits for DMA channel 3.

| Bit | 7 | 6 | 5 | 4 | 3 | 2 | 1 | 0 |
|----------|-------|-------|---|---|-------|--------|--------|--------|
| Mnemonic | DMAEN | WABEN | — | — | EPDIR | EPNUM2 | EPNUM1 | EPNUM0 |
| Type | R/W | R/W | R | R | R/W | R/W | R/W | R/W |
| Default | 0 | 0 | 0 | 0 | 0 | 0 | 0 | 0 |

| BIT | MNEMONIC | NAME | DESCRIPTION |
|-----|------------|---------------------------|---|
| 7 | DMAEN | DMA enable | The DMA enable bit is set to a 1 by the MCU to enable this DMA channel. Before enabling the DMA channel, all other DMA channel configuration bits should be set to the desired value. |
| 6 | WABEN | Wrap-around buffer enable | The wrap-around buffer enable bit is used by the MCU to enable or disable the wrap-around buffer operation. The wrap-around buffer operation can only be used by isochronous out endpoints or isochronous in endpoints that are serviced by the DMA channels. The wrap-around buffer operation is enabled or disabled separately for each DMA channel. For a DMA channel, the MCU should set this bit to a 1 to enable the wrap-around buffer operation and clear this bit to a 0 to disable the wrap-around buffer operation. Both the DMA channel and UBM logic use this bit to determine the required functionality. |
| 5 | — | Reserved | Reserved for future use |
| 4 | — | Reserved | Reserved for future use |
| 3 | EPDIR | USB endpoint direction | The USB endpoint direction bit controls the direction of data transfer by this DMA channel. The MCU should set this bit to a 1 to configure this DMA channel to be used for a USB in endpoint. The MCU should clear this bit to a 0 to configure this DMA channel to be used for a USB out endpoint. |
| 2:0 | EPNUM(2:0) | USB endpoint number | The USB endpoint number bits are set by the MCU to define the USB endpoint number supported by this DMA channel. Keep in mind that endpoint 0 is always used for the control endpoint, which is serviced by the MCU and not a DMA channel. 001b = Endpoint 1, 010b = Endpoint 2, ..., 111b = Endpoint 7 |

A.5.2.4 DMA Channel 2 Time Slot Assignment Register (Low Byte) (DMATSL2 – Address FFF6h)

The DMA channel 2 time slot assignment register (low byte) contains the eight least significant time slot bits. The time slot assignment bits are used to define which CODEC port interface time slots are supported by DMA channel 2. The DMA channel will control the transfer of data between the USB endpoint buffers and the CODEC port interface registers based on which bits are set. The direction of the data transfer depends on the value of the USB endpoint direction bit (**EPDIR**) in the DMA channel 2 control register. The desired time slot bits should be set by the MCU before the DMA channel is enabled. There are a total of fourteen time slot bits for each DMA channel.

| Bit | 7 | 6 | 5 | 4 | 3 | 2 | 1 | 0 |
|----------|------|------|------|------|------|------|------|------|
| Mnemonic | TSL7 | TSL6 | TSL5 | TSL4 | TSL3 | TSL2 | TSL1 | TSL0 |
| Type | R/W | R/W | R/W | R/W | R/W | R/W | R/W | R/W |
| Default | 0 | 0 | 0 | 0 | 0 | 0 | 0 | 0 |

| BIT | MNEMONIC | NAME | DESCRIPTION |
|-----|----------|----------------------|--|
| 7:0 | TSL(7:0) | Time slot assignment | The DMA time slot assignment bits are set to a 1 by the MCU to define the CODEC port interface time slots supported by this DMA channel. |

A.5.2.5 DMA Channel 2 Time Slot Assignment Register (High Byte) (DMATSH2 – Address FFF5h)

The DMA channel 2 time slot assignment register (high byte) contains the six most significant time slot bits. In addition, this register contains the bytes per time slot control bits.

| Bit | 7 | 6 | 5 | 4 | 3 | 2 | 1 | 0 |
|----------|-------|-------|-------|-------|-------|-------|------|------|
| Mnemonic | BPTS1 | BPTS0 | TSL13 | TSL12 | TSL11 | TSL10 | TSL9 | TSL8 |
| Type | R/W | R/W | R/W | R/W | R/W | R/W | R/W | R/W |
| Default | 0 | 0 | 0 | 0 | 0 | 0 | 0 | 0 |

| BIT | MNEMONIC | NAME | DESCRIPTION |
|-----|-----------|----------------------|--|
| 7:6 | BPTS(1:0) | Bytes per time slot | The bytes per time slot bits are used to define the number of bytes to be transferred for each time slot supported by this DMA channel. 00b = 1 byte, 01b = 2 bytes, 10b = 3 bytes, 11b = 4 bytes |
| 5:0 | TSL(13:8) | Time slot assignment | The DMA time slot assignment bits are set to a 1 by the MCU to define the CODEC port interface time slots supported by this DMA channel. |

A.5.2.6 DMA Channel 2 Control Register (DMATCTL2 – Address FFF4h)

The DMA channel 2 control register is used to store various control bits for DMA channel 2.

| Bit | 7 | 6 | 5 | 4 | 3 | 2 | 1 | 0 |
|----------|-------|-------|---|---|-------|--------|--------|--------|
| Mnemonic | DMAEN | WABEN | — | — | EPDIR | EPNUM2 | EPNUM1 | EPNUM0 |
| Type | R/W | R/W | R | R | R/W | R/W | R/W | R/W |
| Default | 0 | 0 | 0 | 0 | 0 | 0 | 0 | 0 |

| BIT | MNEMONIC | NAME | DESCRIPTION |
|-----|------------|---------------------------|---|
| 7 | DMAEN | DMA enable | The DMA enable bit is set to a 1 by the MCU to enable this DMA channel. Before enabling the DMA channel, all other DMA channel configuration bits should be set to the desired value. |
| 6 | WABEN | Wrap-around buffer enable | The wrap-around buffer enable bit is used by the MCU to enable or disable the wrap-around buffer operation. The wrap-around buffer operation can only be used by isochronous out endpoints or isochronous in endpoints that are serviced by the DMA channels. The wrap-around buffer operation is enabled or disabled separately for each DMA channel. For a DMA channel, the MCU should set this bit to a 1 to enable the wrap-around buffer operation and clear this bit to a 0 to disable the wrap-around buffer operation. Both the DMA channel and UBM logic use this bit to determine the required functionality. |
| 5 | — | Reserved | Reserved for future use |
| 4 | — | Reserved | Reserved for future use |
| 3 | EPDIR | USB endpoint direction | The USB endpoint direction bit controls the direction of data transfer by this DMA channel. The MCU should set this bit to a 1 to configure this DMA channel to be used for a USB in endpoint. The MCU should clear this bit to a 0 to configure this DMA channel to be used for a USB out endpoint. |
| 2:0 | EPNUM(2:0) | USB endpoint number | The USB endpoint number bits are set by the MCU to define the USB endpoint number supported by this DMA channel. Keep in mind that endpoint 0 is always used for the control endpoint, which is serviced by the MCU and not a DMA channel. 001b = Endpoint 1, 010b = Endpoint 2, ..., 111b = Endpoint 7 |

A.5.2.7 DMA Channel 1 Time Slot Assignment Register (Low Byte) (DMATSL1 – Address FFF0h)

The DMA channel 1 time slot assignment register (low byte) contains the eight least significant time slot bits. The time slot assignment bits are used to define which CODEC port interface time slots are supported by DMA channel 1. The DMA channel will control the transfer of data between the USB endpoint buffers and the CODEC port interface registers based on which bits are set. The direction of the data transfer depends on the value of the USB endpoint direction bit (**EPDIR**) in the DMA channel 1 control register. The desired time slot bits should be set by the MCU before the DMA channel is enabled. There are a total of fourteen time slot bits for each DMA channel.

| Bit | 7 | 6 | 5 | 4 | 3 | 2 | 1 | 0 |
|----------|------|------|------|------|------|------|------|------|
| Mnemonic | TSL7 | TSL6 | TSL5 | TSL4 | TSL3 | TSL2 | TSL1 | TSL0 |
| Type | R/W | R/W | R/W | R/W | R/W | R/W | R/W | R/W |
| Default | 0 | 0 | 0 | 0 | 0 | 0 | 0 | 0 |

| BIT | MNEMONIC | NAME | DESCRIPTION |
|-----|----------|----------------------|--|
| 7:0 | TSL(7:0) | Time slot assignment | The DMA time slot assignment bits are set to a 1 by the MCU to define the CODEC port interface time slots supported by this DMA channel. |

A.5.2.8 DMA Channel 1 Time Slot Assignment Register (High Byte) (DMATSH1 – Address FFEFh)

The DMA channel 1 time slot assignment register (high byte) contains the six most significant time slot bits. In addition, this register contains the bytes per time slot control bits.

| Bit | 7 | 6 | 5 | 4 | 3 | 2 | 1 | 0 |
|----------|-------|-------|-------|-------|-------|-------|------|------|
| Mnemonic | BPTS1 | BPTS0 | TSL13 | TSL12 | TSL11 | TSL10 | TSL9 | TSL8 |
| Type | R/W | R/W | R/W | R/W | R/W | R/W | R/W | R/W |
| Default | 0 | 0 | 0 | 0 | 0 | 0 | 0 | 0 |

| BIT | MNEMONIC | NAME | DESCRIPTION |
|-----|-----------|----------------------|--|
| 7:6 | BPTS(1:0) | Bytes per time slot | The bytes per time slot bits are used to define the number of bytes to be transferred for each time slot supported by this DMA channel. 00b = 1 byte, 01b = 2 bytes, 10b = 3 bytes, 11b = 4 bytes |
| 5:0 | TSL(13:8) | Time slot assignment | The DMA time slot assignment bits are set to a 1 by the MCU to define the CODEC port interface time slots supported by this DMA channel. |

A.5.2.9 DMA Channel 1 Control Register (DMACTL1 – Address FFEHh)

The DMA channel 1 control register is used to store various control bits for DMA channel 1.

| Bit | 7 | 6 | 5 | 4 | 3 | 2 | 1 | 0 |
|----------|-------|-------|---|---|-------|--------|--------|--------|
| Mnemonic | DMAEN | WABEN | — | — | EPDIR | EPNUM2 | EPNUM1 | EPNUM0 |
| Type | R/W | R/W | R | R | R/W | R/W | R/W | R/W |
| Default | 0 | 0 | 0 | 0 | 0 | 0 | 0 | 0 |

| BIT | MNEMONIC | NAME | DESCRIPTION |
|-----|------------|---------------------------|---|
| 7 | DMAEN | DMA enable | The DMA enable bit is set to a 1 by the MCU to enable this DMA channel. Before enabling the DMA channel, all other DMA channel configuration bits should be set to the desired value. |
| 6 | WABEN | Wrap-around buffer enable | The wrap-around buffer enable bit is used by the MCU to enable or disable the wrap-around buffer operation. The wrap-around buffer operation can only be used by isochronous out endpoints or isochronous in endpoints that are serviced by the DMA channels. The wrap-around buffer operation is enabled or disabled separately for each DMA channel. For a DMA channel, the MCU should set this bit to a 1 to enable the wrap-around buffer operation and clear this bit to a 0 to disable the wrap-around buffer operation. Both the DMA channel and UBM logic use this bit to determine the required functionality. |
| 5 | — | Reserved | Reserved for future use |
| 4 | — | Reserved | Reserved for future use |
| 3 | EPDIR | USB endpoint direction | The USB endpoint direction bit controls the direction of data transfer by this DMA channel. The MCU should set this bit to a 1 to configure this DMA channel to be used for a USB in endpoint. The MCU should clear this bit to a 0 to configure this DMA channel to be used for a USB out endpoint. |
| 2:0 | EPNUM(2:0) | USB endpoint number | The USB endpoint number bits are set by the MCU to define the USB endpoint number supported by this DMA channel. Keep in mind that endpoint 0 is always used for the control endpoint, which is serviced by the MCU and not a DMA channel. 001b = Endpoint 1, 010b = Endpoint 2, ..., 111b = Endpoint 7 |

A.5.2.10 DMA Channel 0 Time Slot Assignment Register (Low Byte) (DMATSL0 – Address FFEAh)

The DMA channel 0 time slot assignment register (low byte) contains the eight least significant time slot bits. The time slot assignment bits are used to define which CODEC port interface time slots are supported by DMA channel 0. The DMA channel will control the transfer of data between the USB endpoint buffers and the CODEC port interface registers based on which bits are set. The direction of the data transfer depends on the value of the USB endpoint direction bit (EPDIR) in the DMA channel 0 control register. The desired time slot bits should be set by the MCU before the DMA channel is enabled. There are a total of fourteen time slot bits for each DMA channel.

| Bit | 7 | 6 | 5 | 4 | 3 | 2 | 1 | 0 |
|----------|------|------|------|------|------|------|------|------|
| Mnemonic | TSL7 | TSL6 | TSL5 | TSL4 | TSL3 | TSL2 | TSL1 | TSL0 |
| Type | R/W | R/W | R/W | R/W | R/W | R/W | R/W | R/W |
| Default | 0 | 0 | 0 | 0 | 0 | 0 | 0 | 0 |

| BIT | MNEMONIC | NAME | DESCRIPTION |
|-----|----------|----------------------|--|
| 7:0 | TSL(7:0) | Time slot assignment | The DMA time slot assignment bits are set to a 1 by the MCU to define the CODEC port interface time slots supported by this DMA channel. |

A.5.2.11 DMA Channel 0 Time Slot Assignment Register (High Byte) (DMATSH0 – Address FFE9h)

The DMA channel 0 time slot assignment register (high byte) contains the six most significant time slot bits. In addition, this register contains the bytes per time slot control bits.

| Bit | 7 | 6 | 5 | 4 | 3 | 2 | 1 | 0 |
|----------|-------|-------|-------|-------|-------|-------|------|------|
| Mnemonic | BPTS1 | BPTS0 | TSL13 | TSL12 | TSL11 | TSL10 | TSL9 | TSL8 |
| Type | R/W | R/W | R/W | R/W | R/W | R/W | R/W | R/W |
| Default | 0 | 0 | 0 | 0 | 0 | 0 | 0 | 0 |

| BIT | MNEMONIC | NAME | DESCRIPTION |
|-----|-----------|----------------------|--|
| 7:6 | BPTS(1:0) | Bytes per time slot | The bytes per time slot bits are used to define the number of bytes to be transferred for each time slot supported by this DMA channel. 00b = 1 byte, 01b = 2 bytes, 10b = 3 bytes, 11b = 4 bytes |
| 5:0 | TSL(13:8) | Time slot assignment | The DMA time slot assignment bits are set to a 1 by the MCU to define the CODEC port interface time slots supported by this DMA channel. |

A.5.2.12 DMA Channel 0 Control Register (DMACTL0 – Address FFE8h)

The DMA channel 0 control register is contains various control bits for DMA channel 0.

| Bit | 7 | 6 | 5 | 4 | 3 | 2 | 1 | 0 |
|----------|-------|-------|---|---|-------|--------|--------|--------|
| Mnemonic | DMAEN | WABEN | — | — | EPDIR | EPNUM2 | EPNUM1 | EPNUM0 |
| Type | R/W | R/W | R | R | R/W | R/W | R/W | R/W |
| Default | 0 | 0 | 0 | 0 | 0 | 0 | 0 | 0 |

| BIT | MNEMONIC | NAME | DESCRIPTION |
|-----|------------|---------------------------|---|
| 7 | DMAEN | DMA enable | The DMA enable bit is set to a 1 by the MCU to enable this DMA channel. Before enabling the DMA channel, all other DMA channel configuration bits should be set to the desired value. |
| 6 | WABEN | Wrap-around buffer enable | The wrap-around buffer enable bit is used by the MCU to enable or disable the wrap-around buffer operation. The wrap-around buffer operation can only be used by isochronous out endpoints or isochronous in endpoints that are serviced by the DMA channels. The wrap-around buffer operation is enabled or disabled separately for each DMA channel. For a DMA channel, the MCU should set this bit to a 1 to enable the wrap-around buffer operation and clear this bit to a 0 to disable the wrap-around buffer operation. Both the DMA channel and UBM logic use this bit to determine the required functionality. |
| 5 | — | Reserved | Reserved for future use |
| 4 | — | Reserved | Reserved for future use |
| 3 | EPDIR | USB endpoint direction | The USB endpoint direction bit controls the direction of data transfer by this DMA channel. The MCU should set this bit to a 1 to configure this DMA channel to be used for a USB in endpoint. The MCU should clear this bit to a 0 to configure this DMA channel to be used for a USB out endpoint. |
| 2:0 | EPNUM(2:0) | USB endpoint number | The USB endpoint number bits are set by the MCU to define the USB endpoint number supported by this DMA channel. Keep in mind that endpoint 0 is always used for the control endpoint, which is serviced by the MCU and not a DMA channel. 001b = Endpoint 1, 010b = Endpoint 2, ..., 111b = Endpoint 7 |

A.5.3 Adaptive Clock Generator Registers

This section describes the memory-mapped registers used for the adaptive clock generator control and operation. The ACG has a set of seven registers.

A.5.3.1 Adaptive Clock Generator Frequency Register (Byte 0) (ACGFRQ0 – Address FFE7h)

The adaptive clock generator frequency register (byte 0) contains the least significant byte of the 24-bit ACG frequency value. The adaptive clock generator frequency registers, ACGFRQ0, ACGFRQ1, and ACGFRQ2, contain the 24-bit value used to program the ACG frequency synthesizer. The 24-bit value of these three registers is used to determine the CODEC master clock output (MCLKO) signal frequency. See section 2.2.8 for the operation details of the adaptive clock generator including instructions for programming the 24-bit ACG frequency value.

| Bit | 7 | 6 | 5 | 4 | 3 | 2 | 1 | 0 |
|----------|------|------|------|------|------|------|------|------|
| Mnemonic | FRQ7 | FRQ6 | FRQ5 | FRQ4 | FRQ3 | FRQ2 | FRQ1 | FRQ0 |
| Type | R/W | R/W | R/W | R/W | R/W | R/W | R/W | R/W |
| Default | 0 | 0 | 0 | 0 | 0 | 0 | 0 | 0 |

| BIT | MNEMONIC | NAME | DESCRIPTION |
|-----|----------|---------------|--|
| 7:0 | FRQ(7:0) | ACG frequency | The ACG frequency bit values are set by the MCU to program the ACG frequency synthesizer to obtain the desired CODEC master clock output (MCLKO) signal frequency. |

A.5.3.2 Adaptive Clock Generator Frequency Register (Byte 1) (ACGFRQ1 – Address FFE6h)

The adaptive clock generator frequency register (byte 1) contains the middle byte of the 24-bit ACG frequency value.

| Bit | 7 | 6 | 5 | 4 | 3 | 2 | 1 | 0 |
|----------|-------|-------|-------|-------|-------|-------|------|------|
| Mnemonic | FRQ15 | FRQ14 | FRQ13 | FRQ12 | FRQ11 | FRQ10 | FRQ9 | FRQ8 |
| Type | R/W | R/W | R/W | R/W | R/W | R/W | R/W | R/W |
| Default | 0 | 0 | 0 | 0 | 0 | 0 | 0 | 0 |

| BIT | MNEMONIC | NAME | DESCRIPTION |
|-----|-----------|---------------|--|
| 7:0 | FRQ(15:8) | ACG frequency | The ACG frequency bit values are set by the MCU to program the ACG frequency synthesizer to obtain the desired CODEC master clock output (MCLKO) signal frequency. |

A.5.3.3 Adaptive Clock Generator Frequency Register (Byte 2) (ACGFRQ2 – Address FFE5h)

The adaptive clock generator frequency register (byte 2) contains the most significant byte of the 24-bit ACG frequency value.

| Bit | 7 | 6 | 5 | 4 | 3 | 2 | 1 | 0 |
|----------|-------|-------|-------|-------|-------|-------|-------|-------|
| Mnemonic | FRQ23 | FRQ22 | FRQ21 | FRQ20 | FRQ19 | FRQ18 | FRQ17 | FRQ16 |
| Type | R/W | R/W | R/W | R/W | R/W | R/W | R/W | R/W |
| Default | 0 | 0 | 0 | 0 | 0 | 0 | 0 | 0 |

| BIT | MNEMONIC | NAME | DESCRIPTION |
|-----|------------|---------------|--|
| 7:0 | FRQ(23:16) | ACG frequency | The ACG frequency bit values are set by the MCU to program the ACG frequency synthesizer to obtain the desired CODEC master clock output (MCLKO) signal frequency. |

A.5.3.4 Adaptive Clock Generator MCLK Capture Register (Low Byte) (ACGCAPL – Address FFE4h)

The adaptive clock generator MCLK capture register (low byte) contains the least significant byte of the 16-bit CODEC master clock (MCLK) signal cycle count that is captured each time a USB start of frame (SOF) occurs. Basically the value of a 16-bit free running counter, which is clocked with the MCLK signal, is captured at the beginning of each USB frame. The source of the MCLK signal used to clock the 16-bit timer can be selected to be either the MCLKO signal or the MCLKO2 signal. See section 2.2.10 for the operation details of the adaptive clock generator.

| Bit | 7 | 6 | 5 | 4 | 3 | 2 | 1 | 0 |
|----------|------|------|------|------|------|------|------|------|
| Mnemonic | CAP7 | CAP6 | CAP5 | CAP4 | CAP3 | CAP2 | CAP1 | CAP0 |
| Type | R | R | R | R | R | R | R | R |
| Default | 0 | 0 | 0 | 0 | 0 | 0 | 0 | 0 |

| BIT | MNEMONIC | NAME | DESCRIPTION |
|-----|----------|------------------|---|
| 7:0 | CAP(7:0) | ACG MCLK capture | The ACG MCLK capture bit values are updated by hardware each time a USB start of frame occurs. This register contains the least significant byte of the 16-bit value. |

A.5.3.5 Adaptive Clock Generator MCLK Capture Register (High Byte) (ACGCAPH – Address FFE3h)

The adaptive clock generator MCLK capture register (high byte) contains the most significant byte of the 16-bit CODEC master clock (MCLK) signal cycle count that is captured each time a USB start of frame (SOF) occurs.

| Bit | 7 | 6 | 5 | 4 | 3 | 2 | 1 | 0 |
|----------|-------|-------|-------|-------|-------|-------|------|------|
| Mnemonic | CAP15 | CAP14 | CAP13 | CAP12 | CAP11 | CAP10 | CAP9 | CAP8 |
| Type | R | R | R | R | R | R | R | R |
| Default | 0 | 0 | 0 | 0 | 0 | 0 | 0 | 0 |

| BIT | MNEMONIC | NAME | DESCRIPTION |
|-----|-----------|------------------|--|
| 7:0 | CAP(15:8) | ACG MCLK capture | The ACG MCLK capture bit values are updated by hardware each time a USB start of frame occurs. This register contains the most significant byte of the 16-bit value. |

A.5.3.6 Adaptive Clock Generator Divider Control Register (ACGDCTL – Address FFE2h)

The adaptive clock generator divider control register contains the control bits for programming the MCLKI signal divider and the MCLKO signal divider. See section 2.2.10 for the operation details of the adaptive clock generator and how to program these dividers.

| Bit | 7 | 6 | 5 | 4 | 3 | 2 | 1 | 0 |
|----------|-------|-------|-------|-------|---|-------|-------|-------|
| Mnemonic | DIVM3 | DIVM2 | DIVM1 | DIVM0 | — | DIVI2 | DIVI1 | DIVIO |
| Type | R/W | R/W | R/W | R/W | R | R/W | R/W | R/W |
| Default | 0 | 0 | 0 | 0 | 0 | 0 | 0 | 0 |

| BIT | MNEMONIC | NAME | DESCRIPTION |
|-----|-----------|-------------------|---|
| 7:4 | DIVM(3:0) | Divide by M value | The divide by M control bits are set by the MCU to program the MCLKO signal divider. 0000b = divide by 1, 0001b = divide by 2, ..., 1111b = divide by 16 |
| 3 | — | Reserved | Reserved for future use. |
| 2:0 | DIVI(2:0) | Divide by I value | The divide by I control bits are set by the MCU to program the MCLKI signal divider. 000b = divide by 1, 001b = divide by 2, ..., 111b = divide by 8 |

A.5.3.7 Adaptive Clock Generator Control Register (ACGCTL – Address FFE1h)

The adaptive clock generator control register is used to store various control bits for the adaptive clock generator.

| Bit | 7 | 6 | 5 | 4 | 3 | 2 | 1 | 0 |
|----------|---|--------|--------|--------|---|-------|---|---|
| Mnemonic | — | MCLKEN | MCLKCP | MCLKIS | — | DIVEN | — | — |
| Type | R | R/W | R/W | R/W | R | R/W | R | R |
| Default | 0 | 0 | 0 | 0 | 0 | 0 | 0 | 0 |

| BIT | MNEMONIC | NAME | DESCRIPTION |
|-----|----------|---------------------|---|
| 7 | — | Reserved | Reserved for future use |
| 6 | MCLKEN | MCLK output enable | The MCLK output enable bit is set to a 1 by the MCU to enable the MCLKO signal to be an output from the TUSB3200 device. If the MCLKO signal is not being used, then the MCU can clear this bit to a 0 to disable the output. |
| 5 | MCLKCP | MCLK capture source | The MCLK capture source bit is used by the MCU to select between the MCLKO output signal and the MCLKO2 output signal as the source for the 16-bit MCLK cycle counter clock. When this bit is cleared to a 0, the clock used is MCLKO and when this bit is set to a 1 the clock used is MCLKO2. |
| 4 | MCLKIS | MCLK input select | The MCLK input select bit is used by the MCU to select between the MCLKI input signal and the MCLKI2 input signal as a source for MCLK if the internally generated MCLK is not being used. When this bit is cleared to a 0, the clock used is MCLKI and when this bit is set to a 1 the clock used is MCLKI2. |
| 3 | — | Reserved | Reserved for future use |
| 2 | DIVEN | Divider enable | The divider enable bit is set to a 1 by the MCU to enable the divide-by-1 and divide-by-M circuits. The MCU should program the MCLK input select bit, the MCLK capture source bit and the MCLK output enable bit before setting this bit to a 1. |
| 1:0 | — | Reserved | Reserved for future use |

A.5.4 CODEC Port Interface Registers

This section describes the memory-mapped registers used for the CODEC port interface control and operation. The codec port interface has a set of ten registers. Note that the four CODEC port interface configuration registers can only be written to by the MCU if the CODEC port enable bit (CPTEN) in the global control register is a 0.

A.5.4.1 CODEC Port Interface Configuration Register 1 (CPTCNF1 – Address FFE0h)

The CODEC port interface configuration register 1 is used to store various control bits for the CODEC port interface operation.

| Bit | 7 | 6 | 5 | 4 | 3 | 2 | 1 | 0 |
|----------|-------|-------|-------|-------|-------|-------|-------|-------|
| Mnemonic | NTSL4 | NTSL3 | NTSL2 | NTSL1 | NTSL0 | MODE2 | MODE1 | MODE0 |
| Type | R/W | R/W | R/W | R/W | R/W | R/W | R/W | R/W |
| Default | 0 | 0 | 0 | 0 | 0 | 0 | 0 | 0 |

| BIT | MNEMONIC | NAME | DESCRIPTION |
|-----|-----------|----------------------|--|
| 7:3 | NTSL(4:0) | Number of time slots | The number of time slots bits are set by the MCU to program the number of time slots per audio frame. 00000b = 1 time slot per frame, 00001b = 2 time slots per frame, ..., 11111b = 32 time slots per frame |
| 2:0 | MODE(2:0) | Mode select | The mode select bits are set by the MCU to program the CODEC port interface mode of operation. In addition to selecting the desired mode of operation, the MCU must also program the other configuration registers to obtain the correct serial interface format. 000b = mode 0 - General purpose mode 001b = mode 1 - AIC mode 010b = mode 2 - AC '97 1.X mode 011b = mode 3 - AC '97 2.X mode 100b = mode 4 - I ² S mode – 3 serial data outputs and 1 serial data input 101b = mode 5 - I ² S mode – 2 serial data outputs and 2 serial data inputs 110b = mode 6 - I ² S mode – 1 serial data output and 3 serial data inputs 111b = mode 7 - I ² S mode – 4 serial data outputs and no serial data inputs |

A.5.4.2 CODEC Port Interface Configuration Register 2 (CPTCNF2 – Address FDFh)

The CODEC port interface configuration register 2 is used to store various control bits for the CODEC port interface operation.

| Bit | 7 | 6 | 5 | 4 | 3 | 2 | 1 | 0 |
|----------|--------|--------|--------|--------|--------|------|------|------|
| Mnemonic | TSL0L1 | TSL0L0 | BPTSL2 | BPTSL1 | BPTSL0 | TSL2 | TSL1 | TSL0 |
| Type | R/W | R/W | R/W | R/W | R/W | R/W | R/W | R/W |
| Default | 0 | 0 | 0 | 0 | 0 | 0 | 0 | 0 |

| BIT | MNEMONIC | NAME | DESCRIPTION |
|-----|------------|-------------------------|--|
| 7:6 | TSL0L(1:0) | Time slot 0 length | The time slot 0 Length bits are set by the MCU to program the number of serial clock (CSCLK) cycles for time slot 0. 00b = CSCLK cycles for time slot 0 same as other time slots 01b = 8 CSCLK cycles for time slot 0 10b = 16 CSCLK cycles for time slot 0 11b = 32 CSCLK cycles for time slot 0 |
| 5:3 | BPTSL(2:0) | Data bits per time slot | The data bits per time slot bits are set by the MCU to program the number of data bits per audio time slot. Note that this value is not used for the secondary communication address and data time slots. 000b = 8 data bits per time slot 001b = 16 data bits per time slot 010b = 18 data bits per time slot 011b = 20 data bits per time slot 100b = 24 data bits per time slot 101b = 32 data bits per time slot 110b = reserved 111b = reserved |
| 2:0 | TSL(2:0) | Time slot length | The time slot length bits are set by the MCU to program the number of serial clock (CSCLK) cycles for all time slots except time slot 0. 000b = 8 CSCLK cycles per time slot 001b = 16 CSCLK cycles per time slot 010b = 18 CSCLK cycles per time slot 011b = 20 CSCLK cycles per time slot 100b = 24 CSCLK cycles per time slot 101b = 32 CSCLK cycles per time slot 110b = reserved 111b = reserved |

A.5.4.3 CODEC port interface configuration register 3 (CPTCNF2 – Address FFDEh)

The CODEC port interface configuration register 3 is used to store various control bits for the CODEC port interface operation.

| Bit | 7 | 6 | 5 | 4 | 3 | 2 | 1 | 0 |
|----------|------|-------|--------|--------|--------|------|--------|--------|
| Mnemonic | DDLY | TRSEN | CSCLKP | CSYNCP | CSYNCL | BYOR | CSCLKD | CSYNCD |
| Type | R/W | R/W | R/W | R/W | R/W | R/W | R/W | R/W |
| Default | 0 | 0 | 1 | 1 | 0 | 0 | 0 | 0 |

| BIT | MNEMONIC | NAME | DESCRIPTION |
|-----|----------|-----------------|---|
| 7 | DDLY | Data delay | The data delay bit is set to a 1 by the MCU to program a one CSCLK cycle delay of the serial data output and input signals in reference to the leading edge of the CSYNC signal. The MCU should clear this bit to a 0 for no delay between these signals. |
| 6 | TRSEN | 3-State enable | The 3-state enable bit is set to a 1 by the MCU to program the hardware to 3-state the serial data output signal for the time slots during the audio frame that are not valid. The MCU should clear this bit to a 0 to program the hardware to use zero-padding for the serial data output signal for time slots during the audio frame that are not valid. |
| 5 | CSCLKP | CSCLK polarity | The CSCLK polarity bit is used by the MCU to program the clock edge used for the CODEC port interface frame sync (CSYNC) output signal, CODEC port interface serial data output (CDATO) signal and CODEC port interface serial data Input (CDATI) signal. When this bit is set to a 1, the CSYNC signal will be generated with the negative edge of the CODEC port interface serial clock (CSCLK) signal. Also, when this bit is set to a 1, the CDATO signal will be generated with the negative edge of the CSCLK signal and the CDATI signal will be sampled with the positive edge of the CSCLK signal. When this bit is cleared to a 0, the CSYNC signal will be generated with the positive edge of the CSCLK signal. Also, when this bit is cleared to a 0, the CDATO signal will be generated with the positive edge of the CSCLK signal and the CDATI signal will be sampled with the negative edge of the CSCLK signal. |
| 4 | CSYNCP | CSYNC polarity | The CSYNC polarity bit is set to a 1 by the MCU to program the polarity of the CODEC port interface frame sync (CSYNC) output signal to be active high. The MCU should clear this bit to a 0 to program the polarity of the CSYNC output signal to be active low. |
| 3 | CSYNCL | CSYNC length | The CSYNC length bit is set to a 1 by the MCU to program the length of the CODEC port interface frame sync (CSYNC) output signal to be the same number of CSCLK cycles as time slot 0. The MCU should clear this bit to a 0 to program the length of the CSYNC output signal to be one CSCLK cycle. |
| 2 | BYOR | Byte order | The byte order bit is used by the MCU to program the byte order for the data moved by the DMA between the USB endpoint buffer and the CODEC port interface. When this bit is set to a 1, the byte order of each audio sample will be reversed when the data is moved to/from the USB endpoint buffer. When this bit is cleared to a 0, the byte order of the each audio sample will be unchanged. |
| 1 | CSCLKD | CSCLK direction | The CSCLK direction bit is set to a 1 by the MCU to program the direction of the CODEC port interface serial clock (CSCLK) signal as an input to the TUSB3200 device. The MCU should clear this bit to a 0 to program the direction of the CSCLK signal as an output from the TUSB3200 device. |
| 0 | CSYNCD | CSYNC direction | The CSYNC direction bit is set to a 1 by the MCU to program the direction of the CODEC port interface frame sync (CSYNC) signal as an input to the TUSB3200 device. The MCU should clear this bit to a 0 to program the direction of the CSYNC signal as an output from the TUSB3200 device. |

A.5.4.4 CODEC Port Interface Configuration Register 4 (CPTCNF4 – Address FFDDh)

The CODEC port interface configuration register 4 is used to store various control bits for the CODEC port interface operation.

| | | | | | | | | |
|-----------------|--------------|--------------|--------------|--------------|-------------|--------------|--------------|--------------|
| Bit | 7 | 6 | 5 | 4 | 3 | 2 | 1 | 0 |
| Mnemonic | ATSL3 | ATSL2 | ATSL1 | ATSL0 | CLKS | DIVB2 | DIVB1 | DIVB0 |
| Type | R/W | R/W | R/W | R/W | R/W | R/W | R/W | R/W |
| Default | 0 | 0 | 0 | 0 | 0 | 0 | 0 | 0 |

| BIT | MNEMONIC | NAME | DESCRIPTION |
|------------|-----------------|---------------------------------------|---|
| 7:4 | ATSL(3:0) | Command/status address/data time slot | The command/status address/data time slot bits are set by the MCU to program the time slots to be used for the secondary communication address and data values. For the AC '97 modes of operation, this value should be set to 0001b which will result in time slot 1 being used for the address and time slot 2 being used for the data. For the AIC and general-purpose modes of operation, the same time slot is used for both address and data. For the AIC mode of operation, for example, this value should be set to 0111b which will result in time slot 7 being used for both the address and data. 0000b = time slot 0, 0001b = time slot 1, ..., 1111b = time slot 15 |
| 3 | CLKS | Clock select | The clock select bit is used by the MCU to select the source of the clock signal to be used for the divide by B circuit. The MCU sets this bit to a 1 to select the output of the divide by I circuit as the clock for the divide by B circuit. The MCU sets this bit to a 0 to select the output of the divide by M circuit as the clock for the divide by B circuit. |
| 2:0 | DIVB(2:0) | Divide by B value | The divide by B control bits are set by the MCU to program the CSCLK signal divider. 000b = disabled 001b = divide by 2 010b = divide by 3 011b = divide by 4 100b = divide by 5 101b = divide by 6 110b = divide by 7 111b = divide by 8 |

A.5.4.5 CODEC Port Interface Control and Status Register (CPTCTL – Address FFDCh)

The CODEC port interface control and status register contains various control and status bits used for the CODEC port interface operation.

| Bit | 7 | 6 | 5 | 4 | 3 | 2 | 1 | 0 |
|----------|-----|------|-----|------|---|------|------|------|
| Mnemonic | RXF | RXIE | TXE | TXIE | — | CID1 | CID0 | CRST |
| Type | R | R/W | R | R/W | R | R/W | R/W | R/W |
| Default | 0 | 0 | 0 | 0 | 0 | 0 | 0 | 0 |

| BIT | MNEMONIC | NAME | DESCRIPTION |
|-----|----------|------------------------------|---|
| 7 | RXF | Receive data register full | The receive data register full bit is set to a 1 by hardware when a new data value has been received into the receive data register from the CODEC device. This bit is read only and is cleared to a 0 by hardware when the MCU reads the new value from the receive data register. Note that when the MCU writes to the interrupt vector register, the CODEC port interface receive data register full interrupt will be cleared but this status bit will not be cleared at that time. |
| 6 | RXIE | Receive interrupt enable | The receive interrupt enable bit is set to a 1 by the MCU to enable the C-port receive data register full interrupt. |
| 5 | TXE | Transmit data register empty | The transmit data register empty bit is set to a 1 by hardware when the data value in the transmit data register has been sent to the CODEC device. This bit is read only and is cleared to a 0 by hardware when a new data byte is written to the transmit data register by the MCU. Note that when the MCU writes to the interrupt vector register, the CODEC port interface transmit data register empty interrupt will be cleared but this status bit will not be cleared at that time. |
| 4 | TXIE | Transmit interrupt enable | The transmit interrupt enable bit is set to a 1 by the MCU to enable the CODEC port interface transmit data register empty interrupt. |
| 3 | — | Reserved | Reserved for future use. |
| 2:1 | CID(1:0) | CODEC ID | The CODEC ID bits are used by the MCU to select between the primary CODEC device and the secondary CODEC device for secondary communication in the AC '97 modes of operation. When the bits are cleared to 00, the primary CODEC device is selected. When the bits are set to 01, 10 or 11, the secondary CODEC device is selected. Note that when only a primary CODEC device is connected to the TUSB3200, the bits should remain cleared to 00. |
| 0 | CRST | CODEC reset | The CODEC reset bit is used by the MCU to control the CODEC port interface reset (<u>CRESET</u>) output signal from the TUSB3200 device. When this bit is set to a 1, the <u>CRESET</u> signal is a high. When this bit is cleared to a 0, the <u>CRESET</u> signal is active low. At power up this bit is cleared to a 0, which means the <u>CRESET</u> output signal will be active low and will remain active low until the MCU sets this bit to a 1. Note that this output signal is not used in the I ² S modes of operation. |

A.5.4.6 CODEC Port Interface Address Register (CPTADR – Address FFDBh)

The CODEC port interface address register contains the read/write control bit and address bits used for secondary communication between the TUSB3200 MCU and the CODEC device. For write transactions to the CODEC, the 8-bit value in this register will be sent to the CODEC in the designated time slot and appropriate bit locations. Note that for the different modes of operation, the number of address bits and the bit location of the read/write bit is different. For example, the AC '97 modes require 7 address bits and the bit location of the read/write bit to be the most significant bit. The AIC mode only requires 4 address bits and the bit location of the read/write bit to be bit 13 of the 16-bits in the time slot. The MCU should load the read/write and address bits to the correct bit locations within this register for the different modes of operation. Shown below are the read/write control bit and address bits for the AC '97 Mode of operation.

| | | | | | | | | |
|-----------------|------------|------------|------------|------------|------------|------------|------------|------------|
| Bit | 7 | 6 | 5 | 4 | 3 | 2 | 1 | 0 |
| Mnemonic | R/W | A6 | A5 | A4 | A3 | A2 | A1 | A0 |
| Type | R/W | R/W | R/W | R/W | R/W | R/W | R/W | R/W |
| Default | 0 | 0 | 0 | 0 | 0 | 0 | 0 | 0 |

| BIT | MNEMONIC | NAME | DESCRIPTION |
|------------|-----------------|-----------------------------------|--|
| 7 | R/W | Command/status read/write control | The command/status read/write control bit value is set by the MCU to program the type of secondary communication transaction to be done. This bit should be set to a 1 by the MCU for a read transaction and cleared to a 0 by the MCU for a write transaction. |
| 6:0 | A(6:0) | Command/status address | The command/status address value is set by the MCU to program the CODEC device control/status register address to be accessed during the read or write transaction. The command/status address value is updated by hardware with the control/status register address value received from the CODEC device for read transactions. |

A.5.4.7 CODEC Port Interface Data Register (Low Byte) (CPTDATL – Address FFDAh)

The CODEC port interface data register (low byte) contains the least significant byte of the 16-bit command or status data value used for secondary communication between the TUSB3200 MCU and the CODEC device. Note that for general-purpose mode or AIC mode only an 8-bit data value is used for secondary communication.

| | | | | | | | | |
|-----------------|------------|------------|------------|------------|------------|------------|------------|------------|
| Bit | 7 | 6 | 5 | 4 | 3 | 2 | 1 | 0 |
| Mnemonic | D7 | D6 | D5 | D4 | D3 | D2 | D1 | D0 |
| Type | R/W | R/W | R/W | R/W | R/W | R/W | R/W | R/W |
| Default | 0 | 0 | 0 | 0 | 0 | 0 | 0 | 0 |

| BIT | MNEMONIC | NAME | DESCRIPTION |
|------------|-----------------|---------------------|---|
| 7:0 | D(7:0) | Command/status data | The command/status data value is set by the MCU with the command data to be transmitted to the CODEC device for write transactions. The command/status data value is updated by hardware with the status data received from the CODEC device for read transactions. |

A.5.4.8 CODEC Port Interface Data Register (High Byte) (CPTDATH – Address FFD9h)

The CODEC port interface data register (high byte) contains the most significant byte of the 16-bit command or status data value used for secondary communication between the TUSB3200 MCU and the CODEC device. This register is not used for general-purpose mode or AIC mode since these modes only support an 8-bit data value for secondary communication.

| Bit | 7 | 6 | 5 | 4 | 3 | 2 | 1 | 0 |
|----------|-----|-----|-----|-----|-----|-----|-----|-----|
| Mnemonic | D15 | D14 | D13 | D12 | D11 | D10 | D9 | D8 |
| Type | R/W | R/W | R/W | R/W | R/W | R/W | R/W | R/W |
| Default | 0 | 0 | 0 | 0 | 0 | 0 | 0 | 0 |

| BIT | MNEMONIC | NAME | DESCRIPTION |
|-----|----------|---------------------|---|
| 7:0 | D(15:8) | Command/status data | The command/status data value is set by the MCU with the command data to be transmitted to the CODEC device for write transactions. The command/status data value is updated by hardware with the status data received from the CODEC device for read transactions. |

A.5.4.9 CODEC Port Interface Valid Time Slots Register (Low Byte) (CPTVSL – Address FFD8h)

The CODEC port interface valid time slots register (low byte) contains the control bits used to specify which time slots in the audio frame contain valid data. This register is only used in the AC '97 modes of operation.

| Bit | 7 | 6 | 5 | 4 | 3 | 2 | 1 | 0 |
|----------|-------|-------|--------|--------|--------|---|---|---|
| Mnemonic | VTSL8 | VTSL9 | VTSL10 | VTSL11 | VTSL12 | — | — | — |
| Type | R/W | R/W | R/W | R/W | R/W | R | R | R |
| Default | 0 | 0 | 0 | 0 | 0 | 0 | 0 | 0 |

| BIT | MNEMONIC | NAME | DESCRIPTION |
|-----|------------|-----------------|--|
| 7:3 | VTSL(8:12) | Valid time slot | The valid time slot bits are set to a 1 by the MCU to define which time slots in the audio frame contain valid data. The MCU should clear to a 0 the bits corresponding to time slots that do not contain valid data. Note that bits 7 to 3 of this register correspond to time slots 8 to 12. |
| 2:0 | — | Reserved | Reserved for future use |

A.5.4.10 CODEC Port Interface Valid Time Slots Register (High Byte) (CPTVSLH – Address FFD7h)

The CODEC port interface valid time slots register (high byte) contains the control bits used to specify which time slots in the audio frame contain valid data. In addition the valid frame, primary CODEC ready and secondary CODEC ready bits are contained in this register. This register is only used in the AC '97 modes of operation.

| Bit | 7 | 6 | 5 | 4 | 3 | 2 | 1 | 0 |
|----------|-----|-------|-------|-------|-------|-------|-------|-------|
| Mnemonic | VF | PCRDY | SCRDY | VTSL3 | VTSL4 | VTSL5 | VTSL6 | VTSL7 |
| Type | R/W | R | R | R/W | R/W | R/W | R/W | R/W |
| Default | 0 | 0 | 0 | 0 | 0 | 0 | 0 | 0 |

| BIT | MNEMONIC | NAME | DESCRIPTION |
|-----|-----------|-----------------------|--|
| 7 | VF | Valid frame | The valid frame bit is set to a 1 by the MCU to indicate that the current audio frame contains at least one time slot with valid data. The MCU should clear this bit to a 0 to indicate that the current audio frame does not contain any time slots with valid data. |
| 6 | PCRDY | Primary CODEC ready | The primary CODEC ready bit is updated by hardware each audio frame based on the value of bit 15 in time slot 0 of the incoming serial data from the primary CODEC. This bit is set to a 1 to indicate the primary CODEC is ready for operation. |
| 5 | SCRDY | Secondary CODEC ready | The secondary CODEC ready bit is updated by hardware each audio frame based on the value of bit 15 in time slot 0 of the incoming serial data from the secondary CODEC. This bit is set to a 1 to indicate the secondary CODEC is ready for operation. Note that this bit is only used if a secondary CODEC is connected to the TUSB3200 device. |
| 4:0 | VTSL(3:7) | Valid time slot | The valid time slot bits are set to a 1 by the MCU to define which time slots in the audio frame contain valid data. The MCU should clear to a 0 the bits corresponding to time slots that do not contain valid data. Note that bits 4 to 0 of this register correspond to time slots 3 to 7. |

A.5.5 I²C Interface Registers

This section describes the memory-mapped registers used for the I²C Interface control and operation. The I²C interface has a set of four registers. See section 2.2.17 for the operation details of the I²C Interface.

A.5.5.1 I²C Interface Address Register (I2CADR – Address FFC3h)

The I²C interface address register contains the 7-bit I²C slave device address and the read/write transaction control bit.

| Bit | 7 | 6 | 5 | 4 | 3 | 2 | 1 | 0 |
|----------|-----|-----|-----|-----|-----|-----|-----|-----|
| Mnemonic | A6 | A5 | A4 | A3 | A2 | A1 | A0 | RW |
| Type | R/W | R/W | R/W | R/W | R/W | R/W | R/W | R/W |
| Default | 0 | 0 | 0 | 0 | 0 | 0 | 0 | 0 |

| BIT | MNEMONIC | NAME | DESCRIPTION |
|-----|----------|---------------------|---|
| 7:1 | A(6:0) | Address | The address bit values are set by the MCU to program the 7-bit I ² C slave address of the device to be accessed. Each I ² C slave device should have a unique address on the I ² C bus. This address is used to identify the device on the bus to be accessed and is not the internal memory address to be accessed within the device. |
| 0 | RW | Read/w3rite control | The read/write control bit value is set by the MCU to program the type of I ² C transaction to be done. This bit should be set to a 1 by the MCU for a read transaction and cleared to a 0 by the MCU for a write transaction. |

A.5.5.2 I²C Interface Receive Data Register (I2CDATI – Address FFC2h)

The I²C interface receive data register contains the most recent data byte received from the slave device.

| | | | | | | | | |
|----------|------|------|------|------|------|------|------|------|
| Bit | 7 | 6 | 5 | 4 | 3 | 2 | 1 | 0 |
| Mnemonic | RXD7 | RXD6 | RXD5 | RXD4 | RXD3 | RXD2 | RXD1 | RXD0 |
| Type | R | R | R | R | R | R | R | R |
| Default | 0 | 0 | 0 | 0 | 0 | 0 | 0 | 0 |

| BIT | MNEMONIC | NAME | DESCRIPTION |
|-----|----------|--------------|--|
| 7:0 | RXD(7:0) | Receive data | The receive data byte value is updated by hardware for each data byte received from the I ² C slave device. |

A.5.5.3 I²C Interface Transmit Data Register (I2CDATO – Address FFC1h)

The I²C interface transmit data register contains the next address or data byte to be transmitted to the slave device in accordance with the protocol. Note that for both read and write transactions, the internal register or memory address of the slave device being accessed must be transmitted to the slave device.

| | | | | | | | | |
|----------|------|------|------|------|------|------|------|------|
| Bit | 7 | 6 | 5 | 4 | 3 | 2 | 1 | 0 |
| Mnemonic | TXD7 | TXD6 | TXD5 | TXD4 | TXD3 | TXD2 | TXD1 | TXD0 |
| Type | W | W | W | W | W | W | W | W |
| Default | 0 | 0 | 0 | 0 | 0 | 0 | 0 | 0 |

| BIT | MNEMONIC | NAME | DESCRIPTION |
|-----|----------|---------------|--|
| 7:0 | TXD(7:0) | Transmit data | The transmit data byte value is set by the MCU for each address or data byte to be transmitted to the I ² C slave device. |

A.5.5.4 I²C Interface Control and status register (I2CCTL – Address FFC0h)

The I²C interface control and status register contains various control and status bits used for the I²C interface operation.

| Bit | 7 | 6 | 5 | 4 | 3 | 2 | 1 | 0 |
|----------|-----|------|-----|-----|-----|------|-------|-------|
| Mnemonic | RXF | RXIE | ERR | FRQ | TXE | TXIE | STPRD | STPWR |
| Type | R | R/W | R/W | R/W | R | R/W | R/W | R/W |
| Default | 0 | 0 | 0 | 0 | 0 | 0 | 0 | 0 |

| BIT | MNEMONIC | NAME | DESCRIPTION |
|-----|----------|------------------------------|--|
| 7 | RXF | Receive data register full | The receive data register full bit is set to a 1 by hardware when a new data byte has been received into the receive data register from the slave device. This bit is read only and is cleared to a 0 by hardware when the MCU reads the new byte from the receive data register. Note that when the MCU writes to the interrupt vector register, the I ² C receive data register full interrupt will be cleared but this status bit will not be cleared at that time. |
| 6 | RXIE | Receive interrupt enable | The receive interrupt enable bit is set to a 1 by the MCU to enable the I ² C receive data register full interrupt. |
| 5 | ERR | Error condition | The error condition bit is set to a 1 by hardware when the slave device does not respond. This bit is read/write and can only be cleared by the MCU. |
| 4 | FRQ | Frequency select | The frequency select bit is used by the MCU to program the I ² C serial clock (SCL) output signal frequency. A value of 0 sets the SCL frequency to 100 kHz and a value of 1 sets the SCL frequency to 400 kHz. |
| 3 | TXE | Transmit data register empty | The transmit data register empty bit is set to a 1 by hardware when the data byte in the transmit data register has been sent to the slave device. This bit is read only and is cleared to a 0 by hardware when a new data byte is written to the transmit data register by the MCU. Note that when the MCU writes to the interrupt vector register, the I ² C transmit data register empty interrupt will be cleared but this status bit will not be cleared at that time. |
| 2 | TXIE | Transmit interrupt enable | The transmit interrupt enable bit is set to a 1 by the MCU to enable the I ² C transmit data register empty interrupt. |
| 1 | STPRD | Stop – read transaction | The stop read transaction bit is set to a 1 by the MCU to enable the hardware to generate a stop condition on the I ² C bus after the next data byte from the slave device is received into the receive data register. The MCU should clear this bit to a 0 after the read transaction has concluded. |
| 0 | STPWR | Stop – write transaction | The stop write transaction bit is set to a 1 by the MCU to enable the hardware to generate a stop condition on the I ² C bus after the data byte in the transmit data register is sent to the slave device. The MCU should clear this bit to a 0 after the write transaction has concluded. |

A.5.6 PWM Registers

This section describes the memory-mapped registers used for the PWM output control and operation. The PWM output has a set of three registers.

A.5.6.1 PWM Frequency Register (PWMFRQ – Address FFBFh)

The PWM frequency register contains the control bits for programming the frequency of the PWM output and for enabling the PWM output circuitry.

| Bit | 7 | 6 | 5 | 4 | 3 | 2 | 1 | 0 |
|----------|-------|------|------|------|------|------|------|------|
| Mnemonic | PWMEN | FRQ6 | FRQ5 | FRQ4 | FRQ3 | FRQ2 | FRQ1 | FRQ0 |
| Type | R/W | R/W | R/W | R/W | R/W | R/W | R/W | R/W |
| Default | 0 | 0 | 0 | 0 | 0 | 0 | 0 | 0 |

| BIT | MNEMONIC | NAME | DESCRIPTION |
|-----|----------|-------------------|--|
| 7 | PWMEN | PWM output enable | The PWM output enable bit is set to a 1 by the MCU to enable the PWM output circuitry. |
| 6:0 | FRQ(6:0) | PWM frequency | The PWM frequency control bits are set by the MCU to program the frequency of the PWM output signal. The frequency range defined by the 7-bit value is from 00h = 732.4 Hz to EFh = 93.75 kHz. |

A.5.6.2 PWM Pulse Width Register (Low Byte) (PWMPWL – Address FFBEh)

The PWM pulse width register (low byte) contains the least significant byte of the 16-bit PWM output pulse width value.

| Bit | 7 | 6 | 5 | 4 | 3 | 2 | 1 | 0 |
|----------|-----|-----|-----|-----|-----|-----|-----|-----|
| Mnemonic | PW7 | PW6 | PW5 | PW4 | PW3 | PW2 | PW1 | PW0 |
| Type | R/W | R/W | R/W | R/W | R/W | R/W | R/W | R/W |
| Default | 0 | 0 | 0 | 0 | 0 | 0 | 0 | 0 |

| BIT | MNEMONIC | NAME | DESCRIPTION |
|-----|----------|-----------------|--|
| 7:0 | PW(7:0) | PWM pulse width | The PWM pulse width control bits are set by the MCU to program the pulse width (duty cycle) of the PWM output signal. A value of 0000h results in a 0-V dc level and a value of FFFFh results in a 5-V dc level. |

A.5.6.3 PWM Pulse Width Register (High Byte) (PWMPWH – Address FFBDh)

The PWM pulse width register (high byte) contains the most significant byte of the 16-bit PWM output pulse width value.

| Bit | 7 | 6 | 5 | 4 | 3 | 2 | 1 | 0 |
|----------|------|------|------|------|------|------|-----|-----|
| Mnemonic | PW15 | PW14 | PW13 | PW12 | PW11 | PW10 | PW9 | PW8 |
| Type | R/W | R/W | R/W | R/W | R/W | R/W | R/W | R/W |
| Default | 0 | 0 | 0 | 0 | 0 | 0 | 0 | 0 |

| BIT | MNEMONIC | NAME | DESCRIPTION |
|-----|----------|-----------------|--|
| 7:0 | PW(15:8) | PWM pulse width | The PWM pulse width control bits are set by the MCU to program the pulse width (duty cycle) of the PWM output signal. A value of 0000h results in a 0-V dc level and a value of FFFFh results in a 5-V dc level. |

A.5.7 Miscellaneous Registers

This section describes the memory-mapped registers used for the control and operation of miscellaneous functions in the TUSB3200 device. The registers include the USB out endpoint interrupt register, the USB in endpoint interrupt register, the interrupt vector register, the global control register, and the memory configuration register.

A.5.7.1 USB Out Endpoint Interrupt Register (OEPINT – Address FFB4h)

The USB out endpoint interrupt register contains the interrupt pending status bits for the USB out endpoints. These bits do not apply to the USB isochronous endpoints. Also, these bits are read only by the MCU and are used for diagnostic purposes only.

| Bit | 7 | 6 | 5 | 4 | 3 | 2 | 1 | 0 |
|----------|-------|-------|-------|-------|-------|-------|-------|-------|
| Mnemonic | OEPI7 | OEPI6 | OEPI5 | OEPI4 | OEPI3 | OEPI2 | OEPI1 | OEPI0 |
| Type | R | R | R | R | R | R | R | R |
| Default | 0 | 0 | 0 | 0 | 0 | 0 | 0 | 0 |

| BIT | MNEMONIC | NAME | DESCRIPTION |
|-----|-----------|------------------------|--|
| 7:0 | OEPI(7:0) | Out endpoint interrupt | The out endpoint interrupt status bit for a particular USB out endpoint is set to a 1 by the UBM when a successful completion of a transaction occurs to that out endpoint. When a bit is set, an interrupt to the MCU will be generated and the corresponding interrupt vector will result. The status bit will be cleared when the MCU writes to the interrupt vector register. These bits do not apply to isochronous out endpoints. |

A.5.7.2 USB In Endpoint Interrupt Register (IEPINT – Address FFB3h)

The USB in endpoint interrupt register contains the interrupt pending status bits for the USB in endpoints. These bits do not apply to the USB isochronous endpoints. Also, these bits are read only by the MCU and are used for diagnostic purposes only.

| Bit | 7 | 6 | 5 | 4 | 3 | 2 | 1 | 0 |
|----------|-------|-------|-------|-------|-------|-------|-------|-------|
| Mnemonic | IEPI7 | IEPI6 | IEPI5 | IEPI4 | IEPI3 | IEPI2 | IEPI1 | IEPI0 |
| Type | R | R | R | R | R | R | R | R |
| Default | 0 | 0 | 0 | 0 | 0 | 0 | 0 | 0 |

| BIT | MNEMONIC | NAME | DESCRIPTION |
|-----|-----------|-----------------------|--|
| 7:0 | IEPI(7:0) | In endpoint interrupt | The in endpoint interrupt status bit for a particular USB in endpoint is set to a 1 by the UBM when a successful completion of a transaction occurs to that in endpoint. When a bit is set, an interrupt to the MCU will be generated and the corresponding interrupt vector will result. The status bit will be cleared when the MCU writes to the interrupt vector register. These bits do not apply to isochronous in endpoints. |

A.5.7.3 Interrupt Vector Register (VECINT – Address FFB2H)

The interrupt vector register contains a 6-bit vector value that identifies the interrupt source for the INT0 input to the MCU. All of the TUSB3200 internal interrupt sources and the external interrupt input to the device are ORed together to generate the internal INT0 signal to the MCU. When there is not an interrupt pending, the interrupt vector value will be set to 24h. To clear any interrupt and update the interrupt vector value to the next pending interrupt, the MCU should simply write any value to this register. The interrupt priority is fixed in order, ranging from vector value 1Fh with the highest priority to vector value 00h with the lowest priority.

| Bit | 7 | 6 | 5 | 4 | 3 | 2 | 1 | 0 |
|----------|---|---|-------|-------|-------|-------|-------|-------|
| Mnemonic | — | — | IVEC5 | IVEC4 | IVEC3 | IVEC2 | IVEC1 | IVEC0 |
| Type | R | R | R | R | R | R | R | R |
| Default | 0 | 0 | 0 | 0 | 0 | 0 | 0 | 0 |

| BIT | MNEMONIC | NAME | DESCRIPTION | |
|-----|-----------|------------------|---|---|
| 7 | — | Reserved | Reserved for future use | |
| 6 | — | Reserved | Reserved for future use | |
| 5:0 | IVEC(5:0) | Interrupt vector | 00h = USB out endpoint 0 01h = USB out endpoint 1 02h = USB out endpoint 2 03h = USB out endpoint 3 04h = USB out endpoint 4 05h = USB out endpoint 5 06h = USB out endpoint 6 07h = USB out endpoint 7 08h = USB in endpoint 0 09h = USB in endpoint 1 0Ah = USB in endpoint 2 0Bh = USB in edpoint 3 0Ch = USB in endpoint 4 0Dh = USB in endpoint 5 0Eh = USB in endpoint 6 0Fh = USB in endpoint 7 | 10h = USB setup stage transaction over-write 11h = Reserved 12h = USB setup stage transaction 13h = USB pseudo start-of-frame 14h = USB start-of-frame 15h = USB function resume 16h = USB function suspend 17h = USB function reset 18h = C-port receive data register full 19h = C-port transmit data register empty 1Ah = Reserved 1Bh = Reserved 1Ch = I ² C receive data register full 1Dh = I ² C transmit data register empty 1Eh = Reserved 1Fh = External interrupt input |
| | | | 20h – 23h = Reserved 24h = No interrupt pending 25h – 3Fh = Reserved | |

A.5.7.4 Global Control Register (GLOBCTL – Address FFB1h)

The global control register contains various global control bits for the TUSB3200 device.

| Bit | 7 | 6 | 5 | 4 | 3 | 2 | 1 | 0 |
|----------|--------|--------|-------|---|---|------|---|-------|
| Mnemonic | MCUCLK | XINTEN | PUDIS | — | — | LPWR | — | CPTEN |
| Type | R/W | R/W | R/W | R | R | R/W | R | R/W |
| Default | 0 | 0 | 0 | 0 | 0 | 0 | 0 | 0 |

| BIT | MNEMONIC | NAME | DESCRIPTION |
|-----|----------|---------------------------|---|
| 7 | MCUCLK | MCU clock select | The MCU clock select bit is used by the MCU to program the clock frequency to be used for the MCU operation. 0b = 12 MHz and 1b = 24 MHz |
| 6 | XINTEN | External interrupt enable | The external interrupt enable bit is set to a 1 by the MCU to enable the use of the external interrupt input to the TUSB3200 device. |
| 5 | PUDIS | Pull-up resistor disable | The pull-up resistor disable bit is set to a 1 by the MCU to disable the TUSB3200 on-chip pull-up resistors. |
| 4 | — | Reserved | Reserved for future use |
| 3 | — | Reserved | Reserved for future use |
| 2 | LPWR | Low power mode disable | The low power mode disable bit is used by the MCU to disable the TUSB3200 semi-low power state. When this bit is cleared to a 0, all USB functional blocks including the USB buffers and configuration blocks are powered-down. For normal operation, the MCU must set this bit to a 1. |
| 1 | — | Reserved | Reserved for future use |
| 0 | CPTEN | CODEC port enable | The CODEC port enable bit is set to a 1 by the MCU to enable the operation of the CODEC port interface. Note that the CODEC port interface configuration registers should be fully programmed before this bit is set by the MCU. |

A.5.7.5 Memory Configuration Register (MEMCFG – Address FFB0h)

The memory configuration register contains various bits pertaining to the memory configuration of the TUSB3200 device.

| Bit | 7 | 6 | 5 | 4 | 3 | 2 | 1 | 0 |
|----------|--------|---------|---------|------|------|------|------|-----|
| Mnemonic | MEMTYP | CODESZ1 | CODESZ0 | REV3 | REV2 | REV1 | REV0 | SDW |
| Type | R | R | R | R | R | R | R | R/W |
| Default | 1 | 0 | 1 | 0 | 0 | 0 | 0 | 0 |

| BIT | MNEMONIC | NAME | DESCRIPTION |
|-----|----------|---------------------|---|
| 7 | MEMTYP | Code memory type | The code memory type bit identifies if the type of memory used for the application program code space is ROM or RAM. For the TUSB3200, an 8K byte RAM is used and this bit is tied to 1. |
| 6:5 | CODESZ | Code space size | The code space size bits identify the size of the application program code memory space. For the TUSB3200, an 8K byte RAM is used and these bits are tied to 01b. 00b = 4K bytes, 01b = 8K bytes, 10b = 16K bytes, 11b = 32K bytes |
| 4:1 | REV | IC revision | The IC revision bits identify the revision of the IC. 0000b = Rev. -, 0001b = Rev. A, ..., 1111b = Rev. F |
| 0 | SDW | Shadow the boot ROM | The shadow the boot ROM bit is set to a 1 by the MCU to switch the MCU memory configuration from boot loader mode to normal operating mode. This should occur after completion of the download of the application program code by the boot ROM. |

Appendix B Mechanical Data

PAH (S-PQFP-G52) PLASTIC QUAD FLATPACK

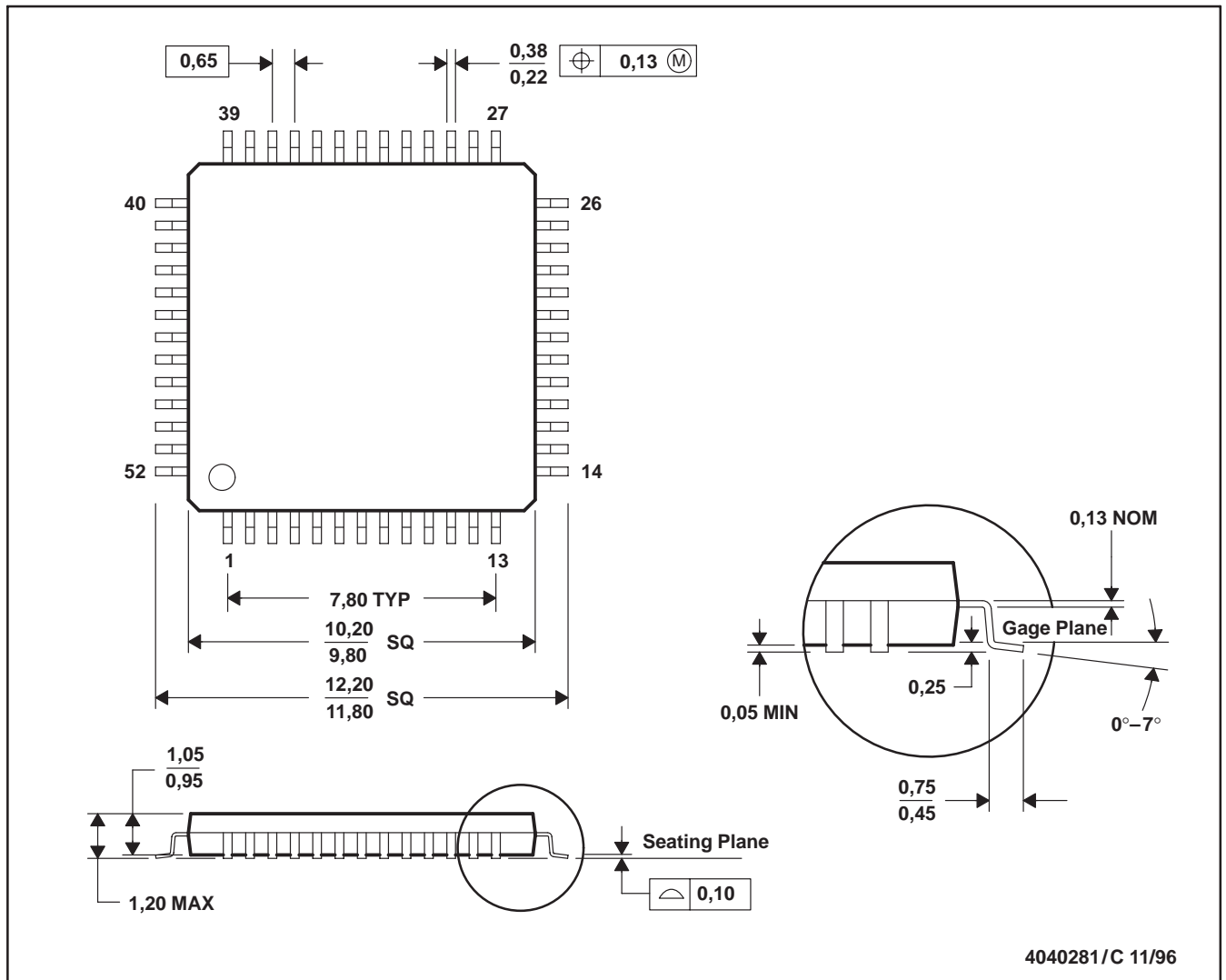

- NOTES: A. All linear dimensions are in millimeters.
 B. This drawing is subject to change without notice.
 C. Falls within JEDEC MS-026

PACKAGING INFORMATION

| Orderable Device | Status ⁽¹⁾ | Package Type | Package Drawing | Pins | Package Qty | Eco Plan ⁽²⁾ | Lead/Ball Finish | MSL Peak Temp ⁽³⁾ |
|------------------|-----------------------|--------------|-----------------|------|-------------|-------------------------|------------------|------------------------------|
| TUSB3200AC97 | OBSOLETE | TQFP | PAH | 52 | | TBD | Call TI | Call TI |
| TUSB3200ACPAH | ACTIVE | TQFP | PAH | 52 | 160 | Green (RoHS & no Sb/Br) | CU NIPDAU | Level-3-260C-168 HR |
| TUSB3200ACPAHG4 | ACTIVE | TQFP | PAH | 52 | 160 | Green (RoHS & no Sb/Br) | CU NIPDAU | Level-3-260C-168 HR |
| TUSB3200ACPAHR | ACTIVE | TQFP | PAH | 52 | 1500 | Green (RoHS & no Sb/Br) | CU NIPDAU | Level-3-260C-168 HR |
| TUSB3200ACPAHRG4 | ACTIVE | TQFP | PAH | 52 | 1500 | Green (RoHS & no Sb/Br) | CU NIPDAU | Level-3-260C-168 HR |
| TUSB3200CPAH | NRND | TQFP | PAH | 52 | 160 | Green (RoHS & no Sb/Br) | CU NIPDAU | Level-4-260C-72 HR |
| TUSB3200CPAHG4 | NRND | TQFP | PAH | 52 | 160 | Green (RoHS & no Sb/Br) | CU NIPDAU | Level-4-260C-72 HR |
| TUSB3200PAH | OBSOLETE | TQFP | PAH | 52 | | TBD | Call TI | Call TI |

⁽¹⁾ The marketing status values are defined as follows:

ACTIVE: Product device recommended for new designs.

LIFEBUY: TI has announced that the device will be discontinued, and a lifetime-buy period is in effect.

NRND: Not recommended for new designs. Device is in production to support existing customers, but TI does not recommend using this part in a new design.

PREVIEW: Device has been announced but is not in production. Samples may or may not be available.

OBSOLETE: TI has discontinued the production of the device.

⁽²⁾ Eco Plan - The planned eco-friendly classification: Pb-Free (RoHS), Pb-Free (RoHS Exempt), or Green (RoHS & no Sb/Br) - please check <http://www.ti.com/productcontent> for the latest availability information and additional product content details.

TBD: The Pb-Free/Green conversion plan has not been defined.

Pb-Free (RoHS): TI's terms "Lead-Free" or "Pb-Free" mean semiconductor products that are compatible with the current RoHS requirements for all 6 substances, including the requirement that lead not exceed 0.1% by weight in homogeneous materials. Where designed to be soldered at high temperatures, TI Pb-Free products are suitable for use in specified lead-free processes.

Pb-Free (RoHS Exempt): This component has a RoHS exemption for either 1) lead-based flip-chip solder bumps used between the die and package, or 2) lead-based die adhesive used between the die and leadframe. The component is otherwise considered Pb-Free (RoHS compatible) as defined above.

Green (RoHS & no Sb/Br): TI defines "Green" to mean Pb-Free (RoHS compatible), and free of Bromine (Br) and Antimony (Sb) based flame retardants (Br or Sb do not exceed 0.1% by weight in homogeneous material)

⁽³⁾ MSL, Peak Temp. -- The Moisture Sensitivity Level rating according to the JEDEC industry standard classifications, and peak solder temperature.

Important Information and Disclaimer: The information provided on this page represents TI's knowledge and belief as of the date that it is provided. TI bases its knowledge and belief on information provided by third parties, and makes no representation or warranty as to the accuracy of such information. Efforts are underway to better integrate information from third parties. TI has taken and continues to take reasonable steps to provide representative and accurate information but may not have conducted destructive testing or chemical analysis on incoming materials and chemicals. TI and TI suppliers consider certain information to be proprietary, and thus CAS numbers and other limited information may not be available for release.

In no event shall TI's liability arising out of such information exceed the total purchase price of the TI part(s) at issue in this document sold by TI to Customer on an annual basis.