

Titan 2000

High-power hi-fi and public-address amplifier

It could be argued that most of the output amplifiers published in this magazine lack power.

Although this is a debatable point, it was felt that a true heavyweight output amplifier would make a welcome change for many constructors. The Titan 2000 can produce 300 watts into 8 Ω , 500 watts into 4 Ω , and 800 watts into 2 Ω . For those who believe that music power is a reputable quantity, the amplifier can deliver 2000 watts of this magical power into 4 Ω .



Brief parameters

<i>Sine-wave power output</i>	300 W into 8 Ω ; 500 W into 4 Ω ; 800 W into 2 Ω
<i>Music power*</i>	2000 W into 4 Ω
<i>Harmonic distortion</i>	< 0.005%
<i>Slew limiting</i>	85 V μs^{-1}
<i>Open-loop bandwidth</i>	55 kHz
<i>Power bandwidth</i>	1.5 Hz – 220 kHz

*See text about the validity of this meaningless quantity.

INTRODUCTION

Amplifier output has been a cause of argument for as long as there have been audio power amplifiers. For domestic use, a power rating of $2 \times 50 \text{ W}$ is more than sufficient. With the volume control at maximum and the use of correctly matched good-quality loudspeakers, this will provide

'PROGRAMMABLE' POWER OUTPUT

The amplifier has been designed in such a manner that its output is 'programmable' as it were. With a sine wave input, it delivers an average power of 300 W into an 8Ω load, which should meet the requirements of all but the power drunk. Compared

age across the loudspeaker and the r.m.s. current flowing into the speaker. The term music power is generally meaningless, because to some manufacturers it means the product of the peak voltage and peak current; to others it means merely double the true power; and to yet others, even more disreputable, it means quadrupling the true power).

1

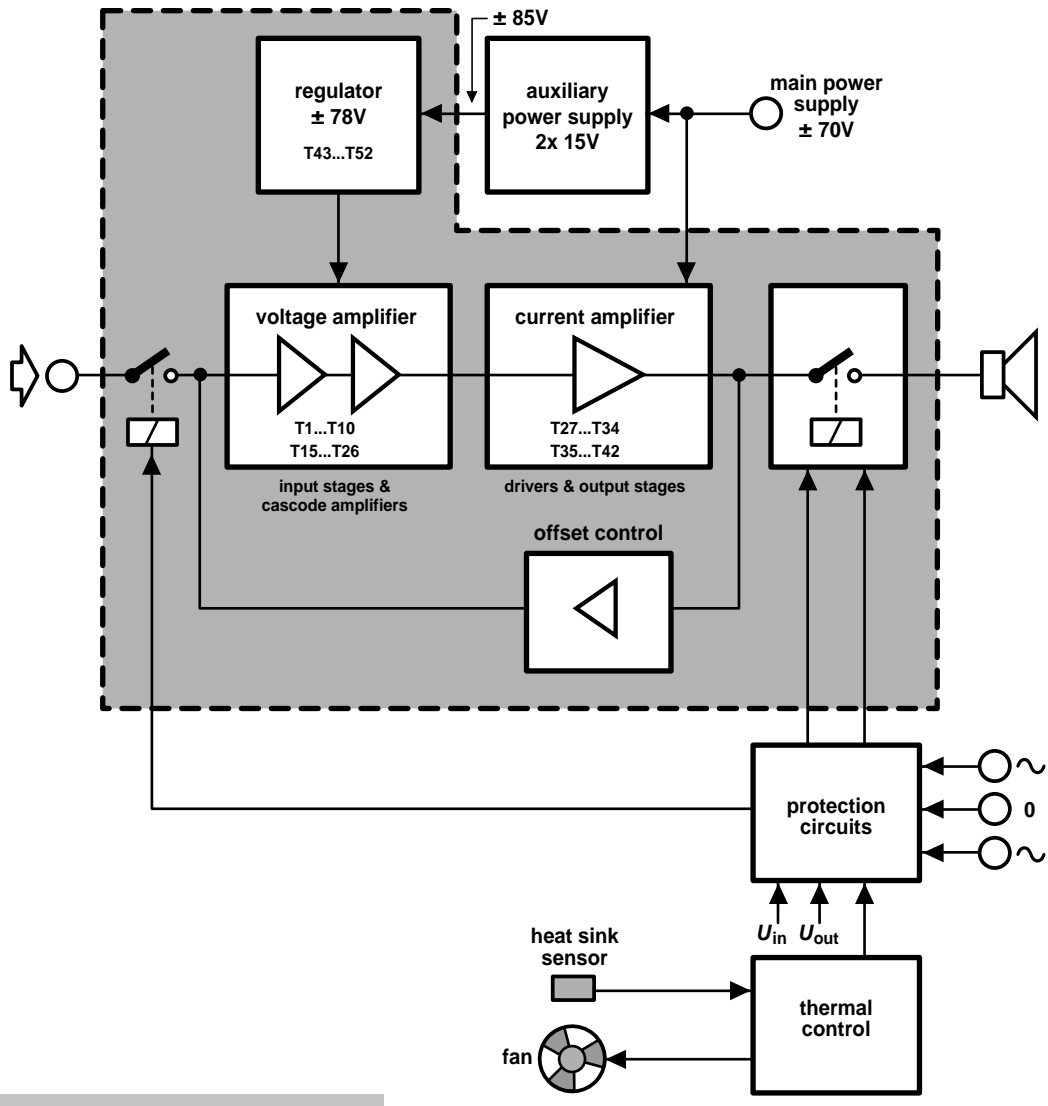

Figure 1. Simplified block diagram of the Titan 2000. The auxiliary power supply, protection networks and thermal control are discrete circuits built on discrete PCBs.

990001 - 12

a sound pressure level (SPL) equivalent to that of a grand piano being played forte in the same room.

However, not all amplifiers are intended for domestic use: many are destined for discos, small music halls and other large rooms. But even here, what power is really required? Since doubling the amplifier output increases the SPL by a barely audible 3 dB, it was felt that 300 watts sine wave power into 8Ω would appeal to many.

with the output of 50 W from a domestic audio amplifier, this gives an increase in SPL of 7.5 dB. If even higher outputs are needed, the load impedance may be lowered to 4Ω , which will give an increase in SPL of 10 dB compared with a 50 W output.

Although music power is a deprecatory term, since it does not really give the true power rating of an amplifier, readers may note that the Titan 2000 can deliver 2 kW of this magical power into 4Ω . (True power is average power, that is, the product of the r.m.s. volt-

However, power is not the only criterion of an amplifier. Low distortion, good slew limiting, and an extended power bandwidth, as possessed by the Titan 2000, are also hallmarks of a good amplifier.

Power bandwidth denotes the frequency range over which the power falls to not less than half its maximum value. This is much more telling than the frequency response, which is usually measured at a much lower output level.

Slew limiting is the maximum input voltage change that can occur in one

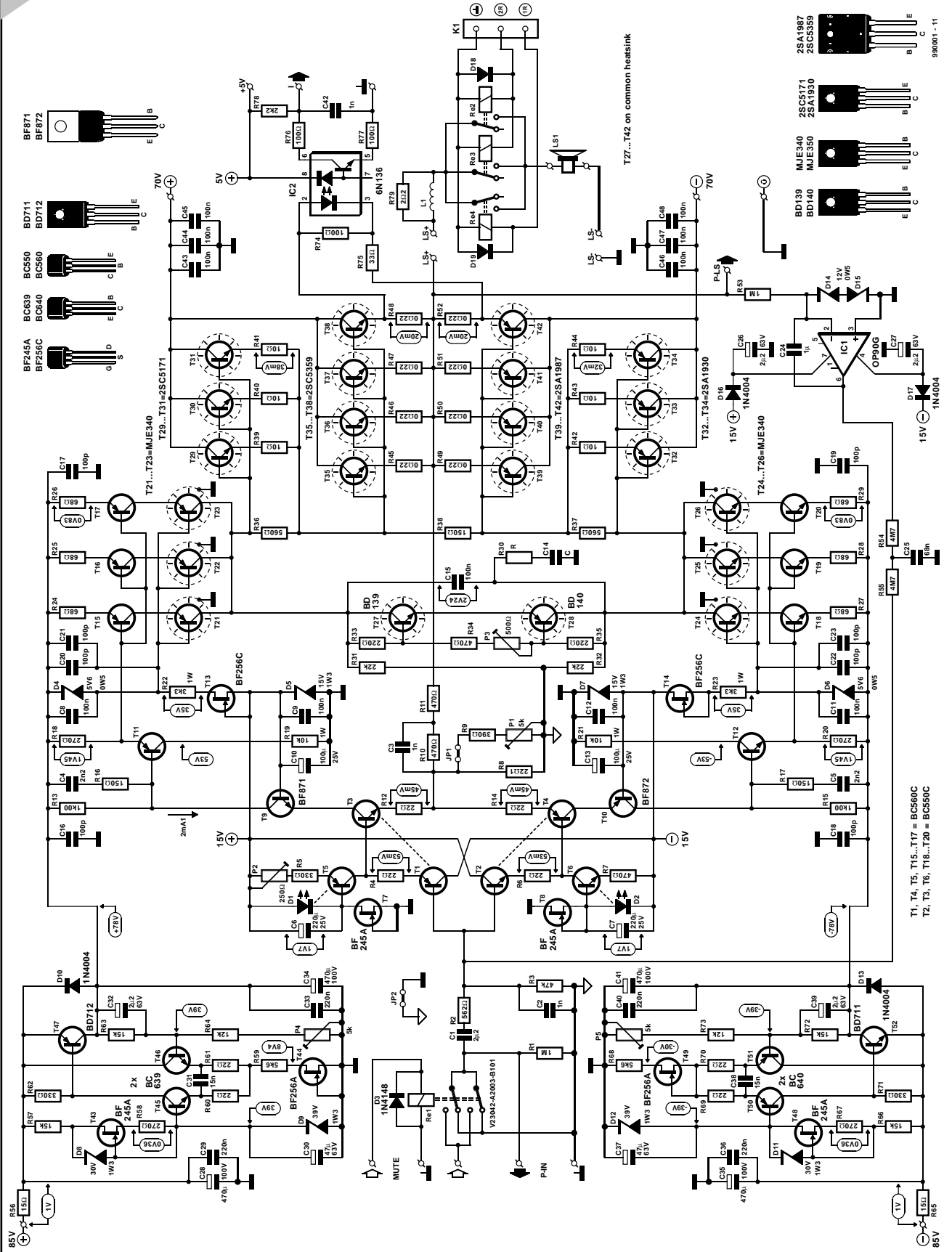
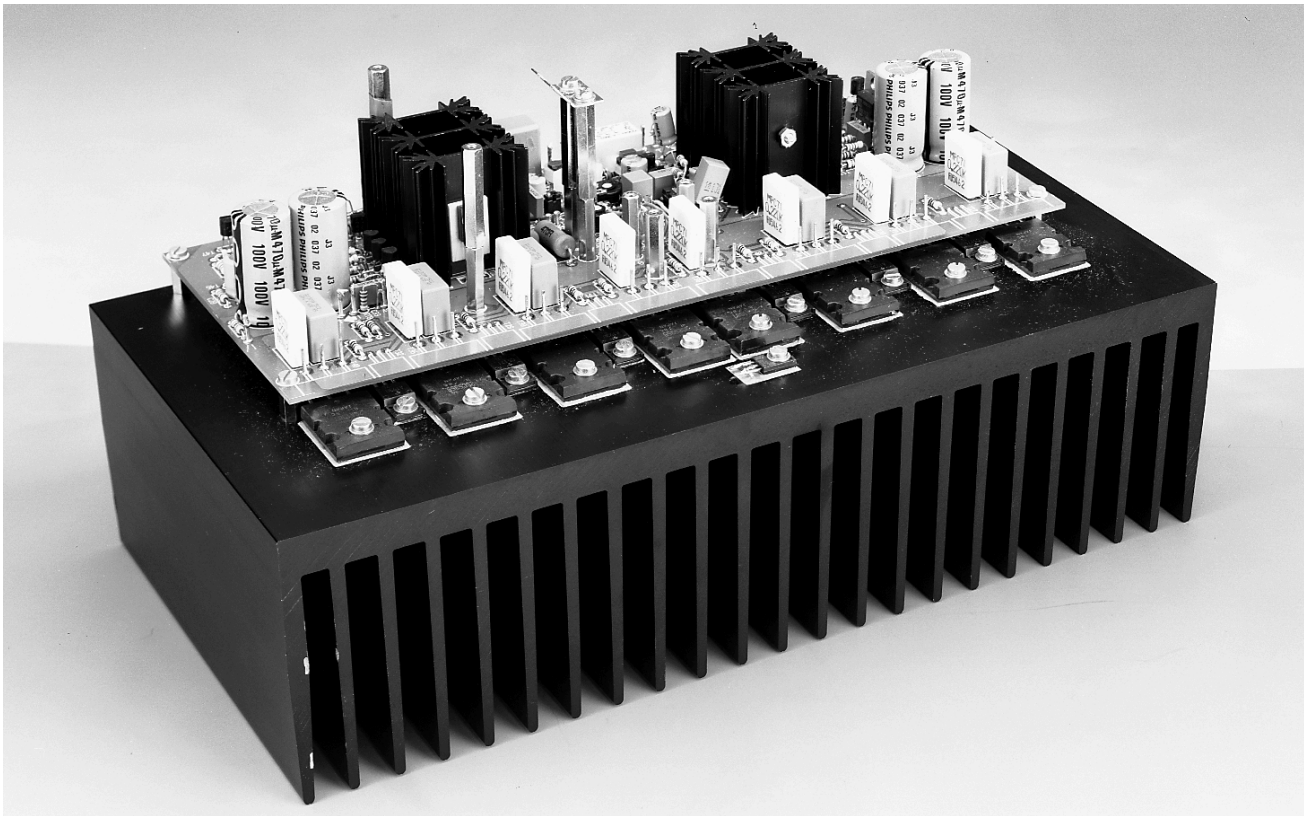

Figure 2. Although the circuit diagram gives the impression of a highly complex design, the amplifier is, in essence, fairly straightforward.



microsecond, and to which the amplifier can respond.

DESIGN CONSIDERATIONS

The Titan 2000 is based on the 'compact power amplifier' published in the May 1997 issue of this magazine. That was a typical domestic amplifier with a power output of 50 W into 8 Ω or 85 W into 4 Ω . The special property of this fully balanced design was the use of current feedback instead of voltage feedback, which resulted in a fast-responding amplifier with a large open-loop bandwidth. The amplifier performed well both as regards instrument test and measurements and listening tests. However, to serve as a basis for the Titan 2000, its output current and drive voltage range had to be increased substantially.

For a start, the supply voltage has to be more than doubled, which means that transistors with a higher power rating have to be used in the power supply. The higher supply voltage also results in larger potential drops across a number of components, and this means that dissipation problems may arise.

The large output current required for the Titan 2000 makes a complete redesign of the current amplifier used in the 'compact power amplifier' unavoidable, since that uses insulated-gate bipolar transistors (IGBTs). Although these are excellent devices, the large spread of their gate-emitter voltage makes their use in parallel net-

works next to impossible. To obtain the requisite output power, the use of parallel networks of symmetrical pairs of transistors is inevitable.

In view of the foregoing, bipolar transistors are used in the current amplifier of the Titan 2000. However, these cannot be driven as readily as IGBTs, which means that current drive instead of voltage drive is used. This entails a substantial upgrading of the driver stages and the preceding cascode amplifiers (which also consist of a couple of parallel-connected transistors). The good news is that the power transistors in the Titan 2000 are considerably less expensive than IGBTs: an important factor when eight of these devices are used.

Finally, the protection circuits have been enhanced in view of the higher voltages and currents. The circuits protecting against direct voltages and short-circuits are supplemented by networks protecting against overload and (too) high temperatures. The latter is coupled to a proportional fan control.

In short, a large part of the Titan 2000 is a virtually new design rather than a modified one.

BRIEF DESCRIPTION

The block diagram of the Titan 2000 is shown in **Figure 1**. The voltage amplifier consists of input stages T_1 - T_{10} , and cascode amplifiers/pre-drivers T_{15} - T_{26} . The current amplifier is formed by driver transistors T_{27} - T_{34} , and output

transistors T_{35} - T_{42} .

The offset control stage prevents any direct voltage appearing at the output of the amplifier.

The loudspeaker is linked to the amplifier by three heavy-duty relays.

The current amplifier operates from a ± 70 V supply, which is provided by two 50 V mains transformers. To enable the voltage amplifier to drive the current amplifier to its full extent, it needs a slightly higher supply voltage to compensate for the inevitable losses caused by inevitable voltage drops. This is accomplished by superimposing a ± 15 V potential from an external auxiliary supply on to the main ± 70 V supply and dropping the resulting voltage to ± 78 V with the aid of regulator T_{43} - T_{52} .

The combined protection circuits constantly compare the input and output voltage of the amplifier: any deviation from the nominal values leads to the output relays disconnecting the loudspeaker and the input relay decoupling the input signal.

The thermal protection circuit monitors the temperature of the heat sink and, if necessary, switches on a fan. If, with the fan operating, the temperature approaches the maximum permissible limit, the output relays are deenergized and disconnect the loudspeaker.

CIRCUIT DESCRIPTION

The circuit diagram of the Titan 2000 is shown in **Figure 2**. In spite of the large number of components, the basic cir-

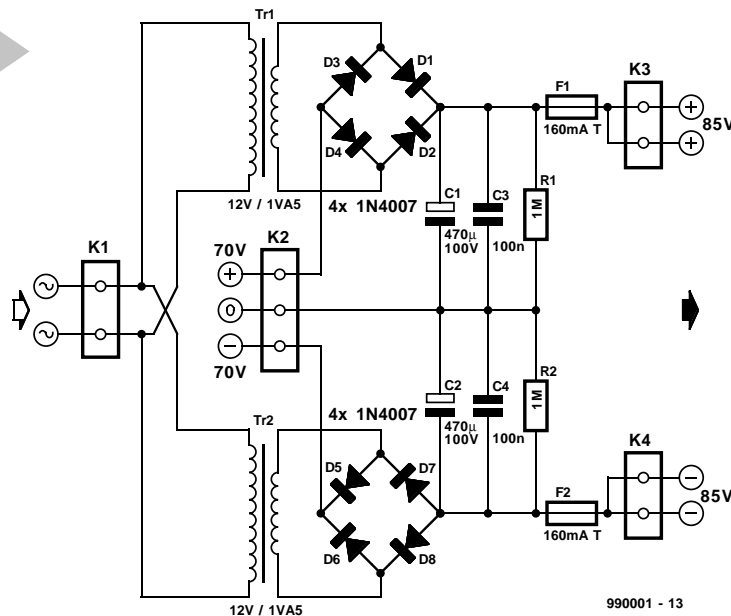

Figure 3. Circuit diagram of the requisite auxiliary power supply.

cuit is straightforward.

As already noted in the previous paragraph, transistors T_1 – T_{10} form the input amplifier, T_{11} and T_{12} are buffers, T_{13} and T_{14} are current sources, T_{15} – T_{26} form the cascode amplifier/pre-driver stage, T_{27} – T_{34} are the driver transistors in the current amplifier, T_{35} – T_{42} are the output transistors, and T_{43} – T_{52} form a sophisticated supply voltage regulator.

Input amplifier

Strictly speaking, the input amplifier is formed by transistors T_3 – T_4 . Cascode stages T_9 – T_{10} serve merely to enable the input section handling the high voltages. These voltages are limited by zener diodes D_5 and D_7 , which are part of the potential divider that also sets the operating points of T_{21} – T_{26} . In view of the requisite stability, the current through the zener diodes is held constant by current sources T_{13} and T_{14} . Resistors R_{22} and R_{23} limit the potential across, and thus the dissipation in, these field-effect transistors.

Otherwise, the input section is virtually identical to that of the 'compact power amplifier'. The drop across the emitter resistors of buffers T_1 and T_2 determines the drop across the emitter resistors of T_3 and T_4 , and consequently the setting of the operating point of the overall input section. To eliminate the influence of temperature variations, T_1 is thermally coupled to T_3 and T_2 to T_4 .

Since the operating point of buffers T_1 and T_2 is critical, current sources T_5 and T_6 have been added. The reference for these current sources is provided by light-emitting diodes (LEDs) D_1 and D_2 . The current through these diodes is determined by current sources T_7

and T_8 . In view of the requisite stability, diode D_1 is thermally coupled to T_5 and D_2 to T_6 .

Any imbalance of the input stages is compensated by making the current through T_5 equal to that through T_6 with potentiometer P_2 .

Cascode amplifiers/pre-drivers

The large output current of the Titan 2000 necessitates a proportionally large pre-drive voltage, which is provided by three parallel-connected cascode amplifiers, T_{15} – T_{26} . The current through these amplifiers is arranged at 10–15 mA, but the current feedback used may cause this level to be appreciably higher. This is the reason that the transistors used in the T_{21} – T_{26} positions are types that can handle currents of up to 50 mA when their collector-emitter voltage is 150 V.

The input section is linked to the cascode amplifiers by buffers T_{11} and T_{12} , which results in a lowering of the input impedance. The arrangement also enables an increase in the values of R_{13} and R_{15} , which results in a 3 dB increase in amplification of the input section.

The function of resistors R_{19} and R_{21} is threefold: they limit the dissipation of the buffers; they obviate the need of an additional voltage to set the operating point of the buffers; they limit the maximum current through the buffers, and thus the cascode amplifiers, to a safe value.

The open-loop amplification of the Titan 2000 is determined solely by those of the input section and cascode amplifiers. The amplification of the input section depends on the ratios $R_{13}:(R_{12}+R_8)$ and $R_{15}:(R_{14}+R_8)$ and, with values as specified is $\times 10$ (i.e., a

gain of 20 dB).

The amplification of the cascode amplifiers is determined largely by the ratio of parallel-connected resistors R_{31} and R_{32} and the parallel network of R_{24} – R_{26} . With values as specified, the amplification is about $\times 850$ (remember, this is a push-pull design), so that the overall amplification of input section plus cascode amplifiers is $\times 8500$ (a gain of close to 80 dB).

Current amplifier

Since one of the design requirements is that the amplifier is to work with loads down to 1.5 Ω , the output stages consist of four parallel-connected pairs of transistors, T_{35} – T_{38} and T_{39} – T_{42} . These transistors have a highly linear transfer characteristic and provide a direct-current amplification that remains virtually constant for currents up to 7 A.

Like the output transistors, the driver stages need to remain within their safe operating area (SOA), which necessitates a threefold parallel network. The transistors used in the driver stages are fast types ($f_T = 200$ MHz).

Setting the bias voltage for the requisite quiescent current is accomplished by balanced transistors T_{27} and T_{28} . These transistors are mounted on the same heat sink as the output transistors and driver transistors to ensure good thermal coupling and current control. Of course, the current rises during full drive conditions, but drops again to its nominal level when the amplifier cools off. The quiescent current is set to 200 mA with potentiometer P_3 .

Owing to the large output current, the connection between amplifier output and loudspeaker is not arranged via a single relay, but via three. Two of these, Re_3 – Re_4 , are controlled in synchrony by the protection circuits. When they are deenergized, their disabling action is delayed slightly to give the contacts of the third relay, Re_2 , time to open, which is of importance in a fault situation.

Input relay Re_1 is switched off in synchrony with Re_2 to ensure that there is no input signal by the time Re_3 and Re_4 are deenergized.

Optoisolator IC₂ serves as sensor for the current protection circuits. The light-emitting diode in it monitors the voltage across R_{48} – R_{52} via potential divider R_{74} – R_{75} , so that the positive as well as the negative output currents are guarded. The use of an optoisolator prevents earth loops and obviates compensation of the ± 70 V common-mode voltage. The +5 V supply for the optoisolator is derived from the protection circuits.

Feedback

The feedback loop runs from the out-

put of the power stages to the junction of T_3 and T_4 via resistors R_{10} and R_{11} . This is current feedback because the current through T_3 and T_4 depends on the potential across R_8 , which is determined largely by the current through R_{10} and R_{11} . The overall voltage amplification of the output amplifier is determined by the ratio $R_8:(R_{10}+R_{11})$.

Compensation

Capacitors C_3 – C_5 and resistors R_{16} , R_{17} form part of the compensation network required for stable operation.

Low-pass filter R_2 – C_2 at the input is essential to prevent fast, that is, high-frequency, signals causing distortion. This filter is also indispensable for stability's sake.

Coupling capacitor C_1 is needed because the available offset compensation network merely redresses the bias current of the input buffers and is not intended to block any direct voltages at the input.

Relay Re_1 at the input enables the input signal to be 'switched off'. It forms part of the overall protection and in particular safeguards the input section against overdrive. The overall protection circuit will be discussed in detail next month.

Network R_9 – P_1 is intended specifically for adjusting the common-mode suppression when two amplifiers are used in a bridge arrangement. It is needed for only one of these amplifiers, and may be interconnected or disabled by jumper JP_1 as needed.

Offset compensation is provided by integrator IC_1 , which ensures that if there is any direct voltage at the output of the amplifier, the operating point of T_1 – T_2 is shifted as needed to keep the output at earth potential. The operational amplifier (op amp) used draws only a tiny current (20 μ A) and has a very small input offset (450 μ V).

Supply voltage for IC_1 is taken from the ± 15 V line for the input section via diodes D_{16} and D_{17} . This arrangement ensures that the supply to the IC is retained for a short while after the main supply is switched off so that any interference is smoothed out.

Diodes D_{14} and D_{15} safeguard the input of IC_1 against (too) high input voltages in fault conditions.

The values of resistors R_{54} and R_{55} arrange the level of the compensating current at not more than 1 μ A, which is sufficient to nullify the difference between the base currents of T_1 and T_2 .

Regulation

Although current feedback has many advantages, it also has a serious drawback: poor supply voltage suppression. This makes it essential for the supply voltage for the voltage amplifier to be regulated. In view of the requisite high symmetrical potential and the fact that the unregulated voltage that serves as input voltage can vary substantially under the influence of the amplifier load, two discrete low-drop regulators, T_{43} – T_{47} and T_{48} – T_{52} are used.

As mentioned before, owing to

inevitable losses through potential drops, the supply voltage for the input section and cascode amplifiers needs to be higher than the main ± 70 V line. Furthermore, the input voltage to the regulators must be higher than the wanted output voltage to ensure effective regulation.

Fortunately, the current drawn by the voltage amplifier is fairly low (about 70 mA) so that the input voltage to the regulators can be increased with a simple auxiliary supply as shown in **Figure 3**. This consists of two small mains transformers, two bridge rectifiers, D_1 – D_4 and D_5 – D_8 , and the necessary reservoir and buffer capacitors.

The ± 15 V output is linked in series with the ± 70 V line to give an unregulated voltage of ± 85 V.

The 39 V reference is provided by zener diode D_9 . This means that the regulator needs to amplify the reference voltage $\times 2$ to obtain the requisite output voltage.

The zener diode is powered by current source T_{43} , to ensure a stable reference, which is additionally buffered by C_{30} .

Differential amplifier T_{45} – T_{46} , whose operating point is set by current source T_{44} , compares the output voltage with the reference via potential divider R_{63} – R_{64} – P_4 . This shows that the output voltage level can be set with P_4 .

Transistor T_{47} is the output stage of the regulator. The output voltage remains stable down to 0.2 V below the input voltage.

Current-feedback

In an amplifier using voltage feedback (Figure a), the differential voltage at its inputs is multiplied by the open-loop amplification. The feedback loop forces the output voltage to a level that, divided by network R_1 – R_2 , is equal to the input voltage.

Whereas an amplifier with voltage feedback has high-impedance inputs, an amplifier with current feedback (Figure b) has an high-impedance and a low-impedance input. Its input stage consists of a buffer with unitary gain between the inverting and non-inverting inputs. Essentially, the inverting input is the low-impedance input. The buffer is followed by an impedance matching stage that converts the output current of the buffer into a directly proportional output voltage.

The current feedback loop operates as follows. When the potential at the non-inverting input rises, the inverting input will also rise, resulting in the buffer current flowing through resistor R_1 . This current, magnified by the impedance matching stage, will cause the output voltage of the amplifier to rise until the output current flowing through resistor R_2 is equal to the buffer current through R_1 . The correct quiescent output voltage can be sustained by a very small buffer current. The closed-loop amplification of the circuit is determined by the ratio $(1+R_2):R_1$.

An interesting property of an amplifier with current feedback is that the closed-loop bandwidth is all but independent of the closed-loop amplification, whereas that of an amplifier with voltage feedback becomes smaller in inverse proportion to the closed-loop amplification – a relation known as the gain-bandwidth product.

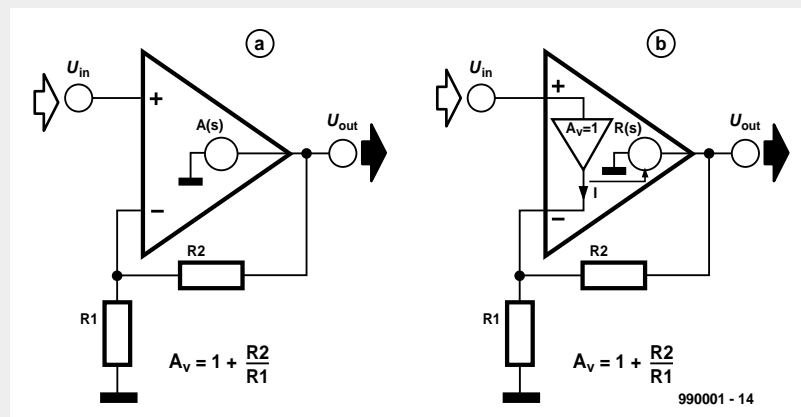

Resistor R_{57} and diode D_8 protect T_{43} against high voltage during switch-on, while D_{10} prevents current flowing through the regulator in the wrong direction.

Capacitors C_{31} and C_{32} enhance the rate of operation of the regulator.

Network $R_{56}-C_{28}-C_{29}$ provides additional smoothing and r.f. decoupling of the ± 85 V lines.

NEXT MONTH

Next month's second and concluding instalment of this article will describe details of the protection circuits, the fan control, and the construction of the amplifier. The instalment will also include detailed specifications and performance characteristics.

[990001-1]

