

PASSIVE INFRA RED MOVEMENT ALARM UNIT

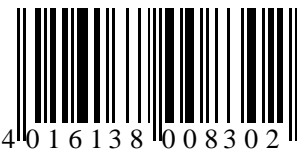

4 0 1 6 1 3 8 0 0 8 3 0 2

Order No 17 25 00



Characteristic features

- ▶ Movement alarm unit with high sensitivity
- ▶ Very small dimensions
- ▶ For wall and ceiling mounting
- ▶ Horizontal preference characteristics
- ▶ Adjustable sensitivity
- ▶ Analog and digital output
- ▶ Wide coverage angle
- ▶ Interference proof circuit concept
- ▶ Simple mounting

Typical areas of application

- ▶ Automatic illumination control
- ▶ Alarm and security systems
- ▶ Presence detection, head counting
- ▶ Contact less hygiene switch
- ▶ Sanitary systems, water fittings
- ▶ Building instrumentation
- ▶ OEM-applications



Description

This miniaturized module is suitable for a large number of applications, in which movement or presence is to be registered. The sensor reacts to the heat radiation from body movement.

The sensitivity can be encoded in 4 steps through soldered joints, which makes it possible for adaptation in different type of applications. The adjustment range is right from a sensitive alarm generating unit to an automatic switch for hygienic applications.

The window comparator integrated in the module, delivers a digital switching signal on detecting a movement, which is TTL and CMOS compatible and can be further processed by a micro controller or a timer.

The amplitude of signal at the analog output depends on the infrared radiation difference and is good enough for suitable triggering within the operating voltage limits. The angular speed of the object can be judged from the frequency. The potential at the reference voltage output lies in the middle of the triggering range.

Technical data

Movement alarm unit PIR-STD	
Power supply	3-12 V DC
Input current	Idle output "H" 1,0 mA Active output "L" 1,4 mA
Coverage	Approx. 12 m to 4 m, Adjustable in 4 steps through soldered joints
Signal bandwidth	0.2 Hz to 10 Hz
Coverage angle	Horizontal $\pm 50^\circ$ Vertical $\pm 30^\circ$
Digital output	Open Collector with pullup max 30 V, 20 mA
Analog output	$0.5 U_b \pm 0.5 U_b$
Operating temperature range	$-20^\circ\text{C} \dots 60^\circ\text{C}$
Ambient humidity	0..90% rH Dew formation not allowed
Dimensions	25mm x 25mm x 20mm Mounting diameter 24 mm \varnothing
Ordering No.	PIR-STD (17 25 00)
Rights reserved for change in technical data due to technological advancements!	





Sensitivity adjustment

There are four soldered joints on the back side of the module. By closing (over-soldering) one of the jumpers, the sensitivity of the module can be reduced.

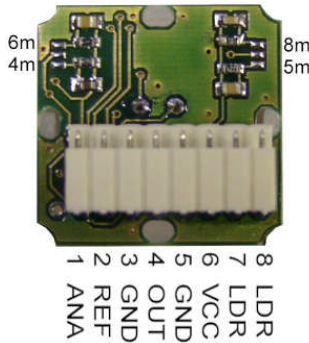

Connector configuration

Pin	Desc.	Function	Remarks
1	ANA	Analog output	0V.. V _{CC}
2	REF	Reference voltage	Approx. V _{CC} / 2
3	GND	Ground	GND
4	OUT	Switching output	O.C. max. 20 mA
5	GND	Ground	GND
6	VCC	Operating voltage	3.. 12 V DC/ 1.4mA
7	LDR	Optical resistance	Optional LDR
8	LDR	Optical resistance	Optional LDR

Method of operation

PIR alarm units operate with pyro-electric sensors, which show maximum sensitivity under the effect of heat radiation from living bodies. At 37° body temperature, the spectral sensitivity lies between 7 and 14 µm. The inner construction of PIR sensors is segmented, i.e. two or more individual elements are interconnected within the unit, so that they mutually compensate with each other. With this arrangement, the self-temperature of sensor is compensated. A MOSFET is integrated in the sensor as an impedance converter because the pyro-elements can be driven only by high ohmic value. In the following evaluation circuit, the change in output voltage is evaluated and DC component is separated out by a high pass filter.

In simple devices, normally a double element sensor is used which show a horizontal preferred direction. The mounting direction of such sensors is also indicated accordingly and it must be noted before putting into application. For mounting in ceiling, four element sensors are more suitable, with which semi-spherical characteristics can be achieved.

Lens

A change in output voltage occurs only when the part segments of sensor experience different levels of infrared radiation. Hence optics or a special Fresnell lens is required which can divide the space in front of the sensor element into segments and in turn makes an image of the part segment of the sensor. If someone looks at the overall system covering optics, sensor and evaluation circuit, then he can realise that there is a considerable contribution of the lens on the capability of the system.

Bandwidth

The change in sensor signal is further processed by only an evaluation circuit. The correct magnitude of band pass filter characteristics decides the capacity of the circuit: Depending on the lens and angular speed of the object, a signal between a bandwidth of 0.05 and 25 Hz normally comes out. But first of all, it should be noted that for a wide range, the lower frequency limit should not be selected too high, otherwise there is a sensitivity loss in case of slow movements. The upper frequency limit decides the sensitivity for fast movements and should be kept much away from power line frequency to avoid interference effect.

Signal evaluation

For simple requirements, the window comparator available on the module is sufficient for signal evaluation. As soon as the signal level at the output of amplifier exceeds a certain limit, a digital switching signal is generated which can be further processed.

For more meticulous jobs, it is better to analyse the pattern of output signal. From the signal amplitude, one can derive the spacing or size and from signal frequency, the angular speed of the moved object is inferred. The signal pattern contains information about the course of movement. A micro-controller can certainly improve the detection effectiveness and can exclude false alarms, which is most required in case of alarm generating units.

In addition to the digital output, our movement alarm units are also provided with an analog output, which stands in line with the amplified signal. Hence, integration is also possible with intelligent OEM-systems.

For further information, please visit our website: www.hygrosens.com



Circuit diagram

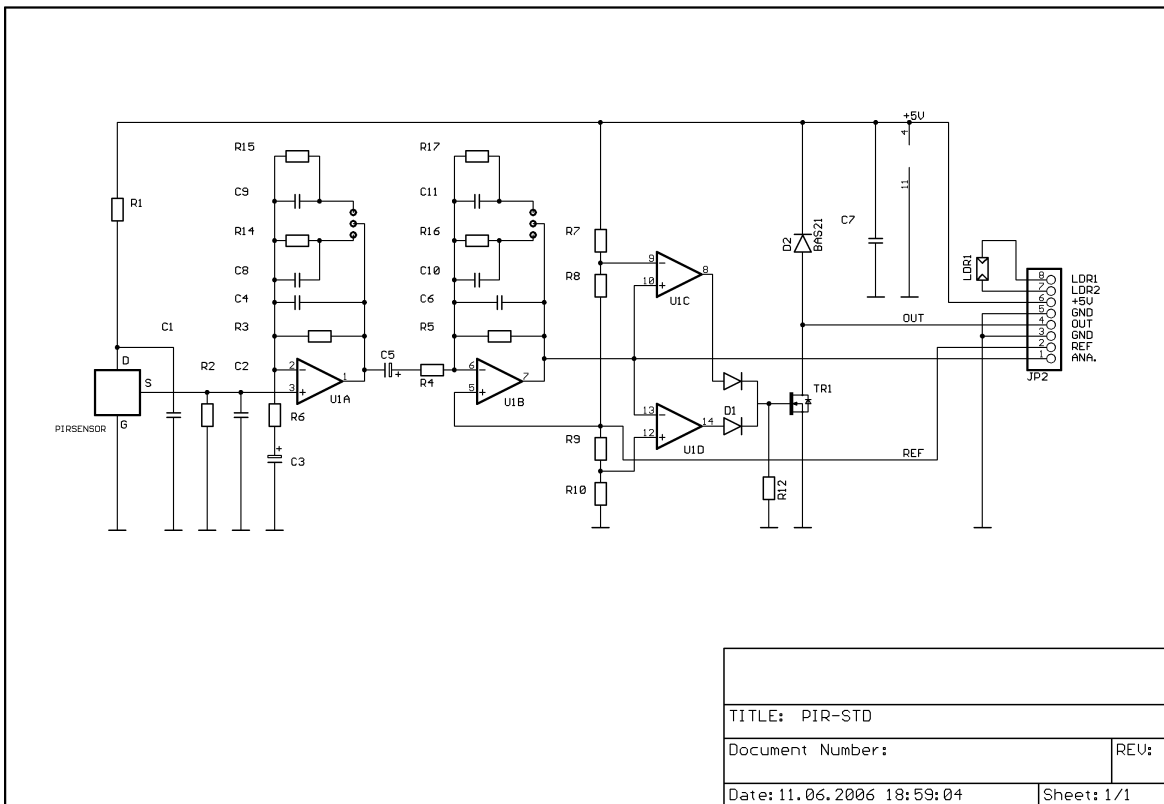

Room segments

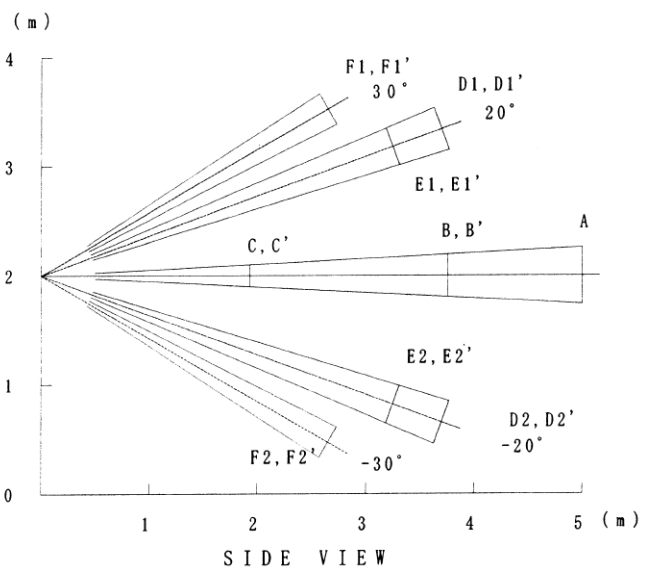
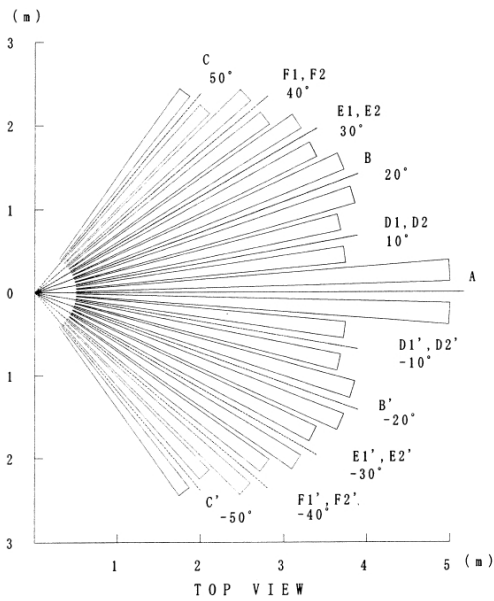

Released 04/2006 | Rights reserved for change in technical data | HYGROSENS INSTRUMENTS GmbH | Postfach 1054 | D-79839 Löfningen | Tel: +49 7654 808969-0 | Fax: +49 7654 808969-9