

TOSHIBA BIPOLAR LINEAR INTEGRATED CIRCUIT SILICON MONOLITHIC

TA7712P, TA7712F

3 PHASE BI-DIRECTIONAL FOR MOTOR CONTROL IC

FEATURES

- FG is not required.
(System for obtaining rotation signal through position sensing)
- Start / stop, CW / CCW and brake functions are provided.
- Gain of position sensing circuit is high, and hysteresis is provided.
- Rotation signal output is provided. (Frequency signal of three times the position sensing output (hall sensor output) can be obtained.)
- External transistor type.

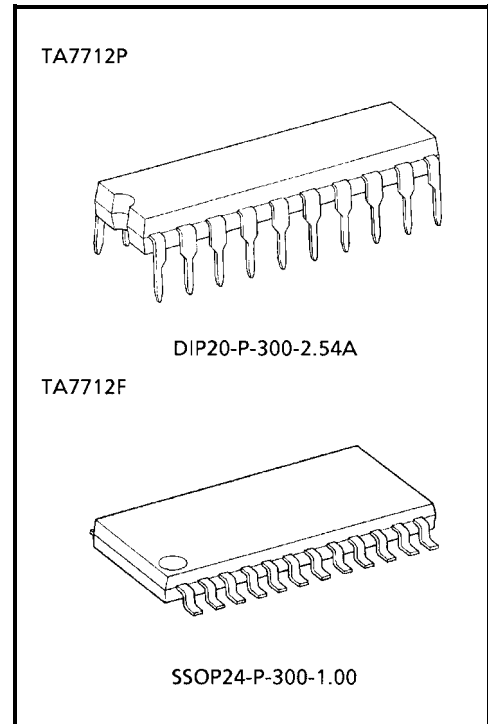

Weight

DIP20-P-300-2.54A : 2.25 g (Typ.)

SSOP24-P-300-1.00 : 0.32 g (Typ.)

BLOCK DIAGRAM

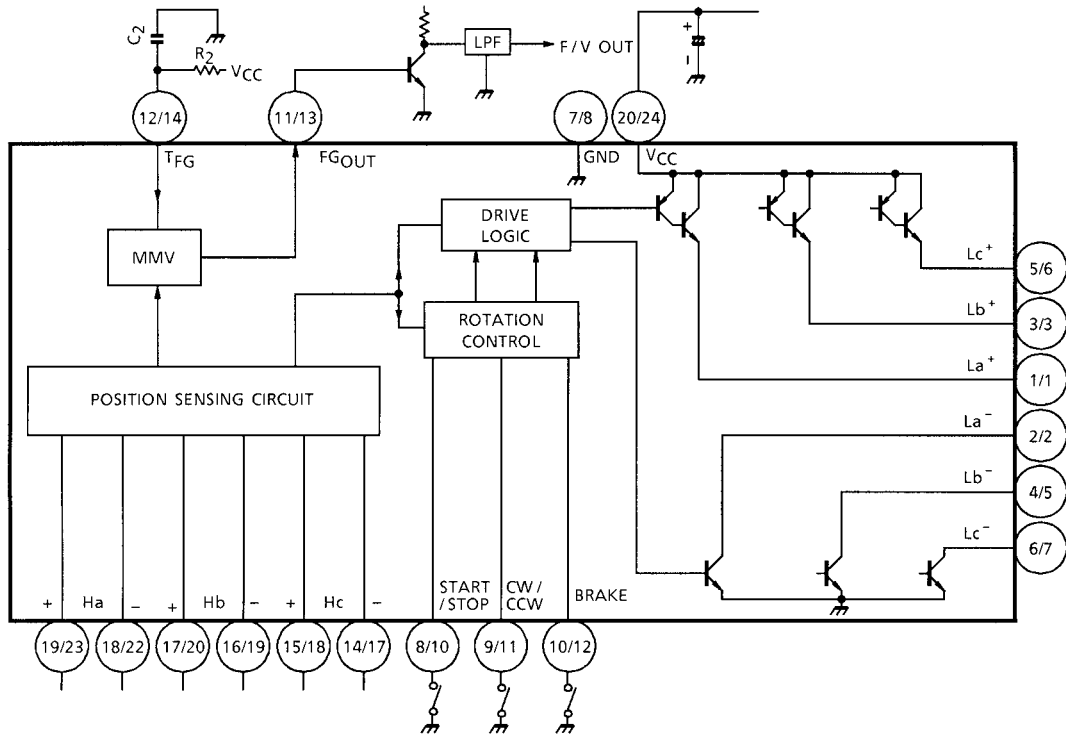

TA7712P / TA7712F

PIN FUNCTION

PIN No.		SYMBOL	FUNCTION DESCRIPTION
P	F		
1	1	La ⁺	a-phase upper drive output terminal
2	2	La ⁻	a-phase lower drive output terminal
3	3	Lb ⁺	b-phase upper drive output terminal
4	5	Lb ⁻	b-phase lower drive output terminal
5	6	Lc ⁺	c-phase upper drive output terminal
6	7	Lc ⁻	c-phase lower drive output terminal
7	8	GND	GND terminal
8	10	START / STOP	START / STOP switch terminal
9	11	CW / CCW	Forward rotation / Reverse rotation switch terminal
10	12	BRAKE	Break terminal
11	13	FG _{OUT}	FG signal output terminal
12	14	T _{FG}	C, R connection terminal
13	—	N. C.	Non connection
14	17	Hc ⁻	c-phase Hall Amp. negative
15	18	Hc ⁺	c-phase Hall Amp. positive input terminal
16	19	Hb ⁻	b-phase Hall Amp. negative input terminal
17	20	Hb ⁺	b-phase Hall Amp. positive input terminal
18	22	Ha ⁻	a-phase Hall Amp. negative input terminal
19	23	Ha ⁺	a-phase Hall Amp. positive input terminal
20	24	V _{CC}	Power supply input terminal

F: (4), (9), (15), (16), (21) pin: non connection

TIMING CHART

Forward rotation (Position sensing signal advances Ha → Hb → Hc.)

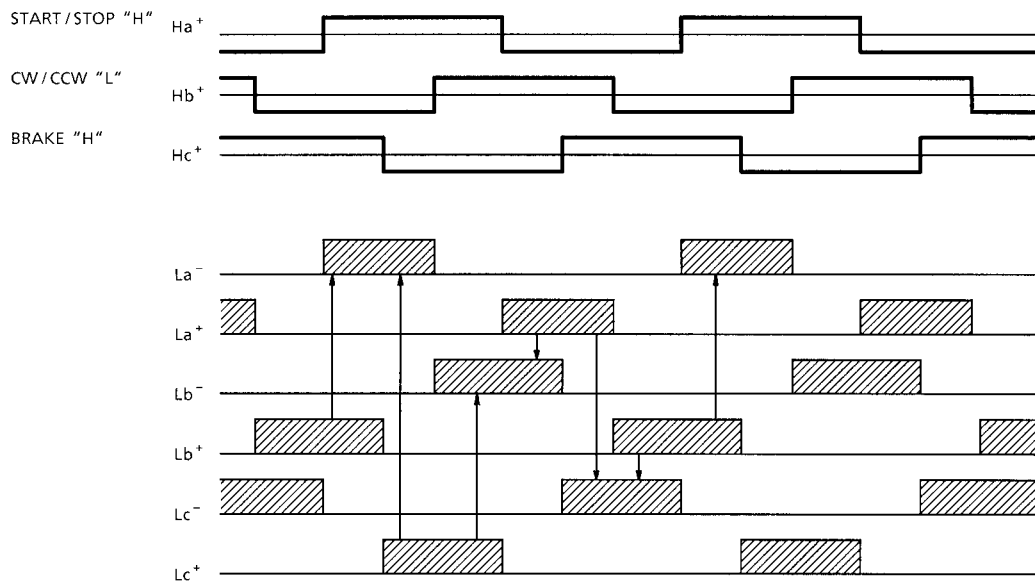

Reverse rotation (Position sensing signal advances Ha → Hc → Hb.)

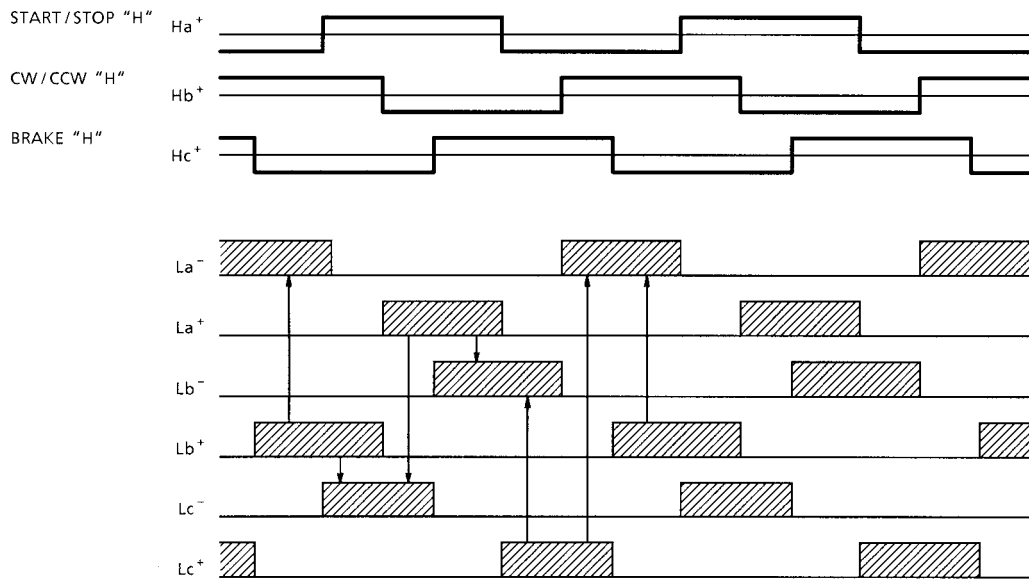

APPLICATION OF TA7712P, TA7712F

Like a video disk player, TA7712P, TA7712F is provided with the stopping function which in a short time, stops the motor having a large inertia, and makes the quick disk-change possible.

To make the frequency generator (FG) unnecessary which was formerly required for fetching the rotation signal, the signal from the position sensing input is ORed and is output to FG output pin (pin (11) / (13)).

Therefore, for FG output, three position sensing outputs (Ha, Hb, Hc) are ORed, and the rotation speed signal of the frequency of six times that of one output can be fetched resulting in making it possible to obtain a sufficient controlling characteristic with the F / V (Frequency-Voltage) conversion method of mono-stable type. The difference from TA7713P is that the stop function is automated in TA7713P, however, it is operated by the external signal in TA7712P.

Description is made on the application of TA7713P in the following.

(1) Operation of FG output (pin (11) / (13)) and TFG (pin (12) / (14))

In Fig.1, Q1 and Q2 are the monostable multi-vibrator to which gate (Q2 base) the signal from each position sensing input of Ha, Hb and Hc is input after ORed and shaped in waveform by FF.

The pulse width of MMV made by Q1 and Q2 is determined by R2 and C2 to be connected to TFG (pin (12) / (14)), and the square wave having the pulse width to be determined by C2 and R2 is output.

Of course, this frequency is proportional to the rotation signal and this frequency is six times the frequency of each position sensing. (6 per 1 electrical rotation)

F / V conversion operation is made through connecting FG0 output to LPF for integration. However, if R2 is made variable, the conversion gain can be controlled.

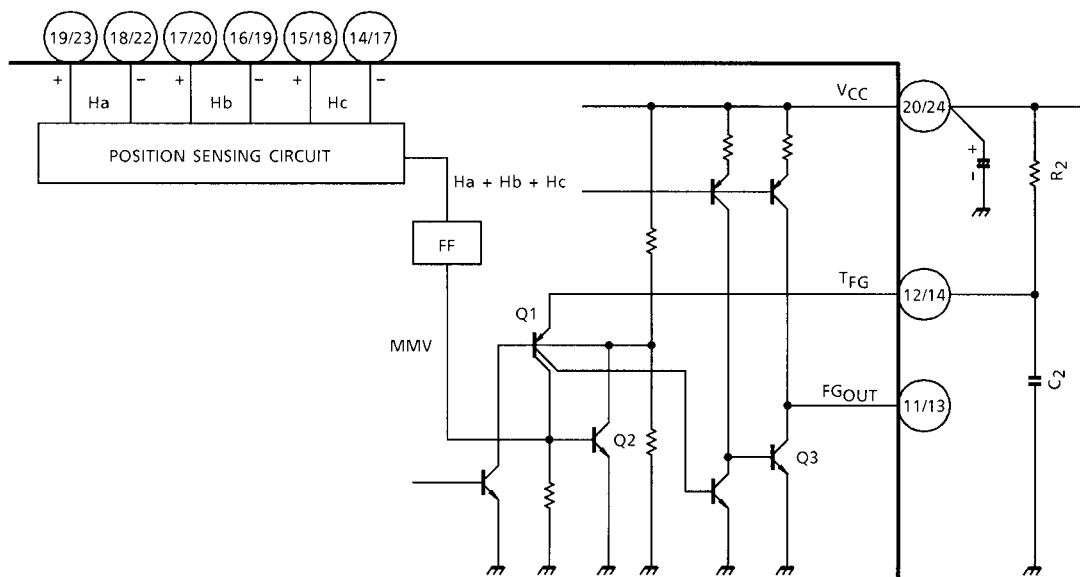

Fig. 1

(2) Each control input

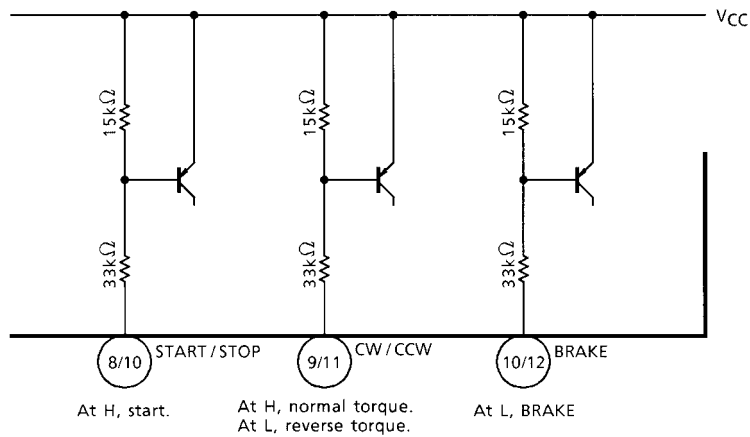

Fig. 2

START / STOP	CW / CCW	BRAKE	OUTPUT
H	H	H	Normal torque mode
H	L	H	Reverse torque mode
H or L	H or L	L	BRAKE mode
L	H or L	H	STOP mode

Note: In STOP mode, Outputs of $La^+ \sim Lc^+$ and $La^- \sim Lc^-$ are all made OFF.
 In BRAKE mode, outputs of $La^+ \sim Lc^+$ are made ON. (source mode)

(3) Output circuit

As shown in the block diagram, in the output circuit, the Darlington emitters of PNP and NPN are provided on the upper side, and the lower side is made as the open collector of NPN. Connect the external transistor in the same manner as that of the application circuit.

MAXIMUM RATINGS (Ta = 25°C)

CHARACTERISTIC		SYMBOL	RATING	UNIT
Power Supply Voltage		V _{CC}	18	V
Output Current		I _O	±25	mA
Position Sensing Circuit Input Voltage (T _j = 25°C)		V _H	500	mV _{p-p}
Power Dissipation	TA8412P	P _D (Note)	1.2	W
	TA8412F		0.5	
Operating Temperature		T _{opr}	-30~75	°C
Storage Temperature		T _{stg}	-55~150	°C

Note: No Heat Sink

ELECTRICAL CHARACTERISTICS (Unless otherwise specified, V_{CC} = 5 V, Ta = 25°C)

CHARACTERISTIC		SYMBOL	TEST CIR-CUIT	TEST CONDITION	MIN	TYP.	MAX	UNIT	
Operating Supply Voltage		V _{CC (opr)}	—		4.75	5.00	5.25	V	
Power Supply Current		I _{CC1}	1	Stop state	—	3.4	6.0	mA	
		I _{CC2}		Output open	—	17.0	26.0		
Saturation Voltage	Upper Side	V _{SAT (U-1)}	2	R _L = 200 Ω	—	1.3	2.0	V	
		V _{SAT (U-2)}		R _L = 2 kΩ	—	1.0	1.3		
	Lower Side	V _{SAT (L-1)}		R _L = 200 Ω	—	0.8	1.2		
		V _{SAT (L-2)}		R _L = 2 kΩ	—	0.18	0.4		
Leak Current	Upper Side	I _{L (U)}	2		—	—	100	μA	
	Lower Side	I _{L (L)}			—	—	100		
Position Sensing Input	Common Mode Voltage Range		—		2.0	—	4.5	V	
	Input Sensitivity				20	—	—	mV _{p-p}	
	Input Hysteresis				2	7	15	mV	
START Input (RUN)	Input Operating Voltage	"H"	V _{IN R (H)}	2	4.0	—	—	V	
		"L"	V _{IN R (L)}	2	—	—	1.0		
	Input Current	"L"	I _{IN R}	2	V _{IN R} = 1.0 V		200	μA	
CW / CCW Input (FWD / REV)	Input Operating Voltage	"H"	V _{IN C (H)}	2	4.0	—	—	V	
		"L"	V _{IN C (L)}		—	—	1.0		
	Input Current	"L"	I _{IN C}		2	V _{IN C} = 1.0 V		200	μA
BRAKE Input (BRAKE)	Input Operating Voltage	"H"	V _{IN B (H)}	2	4.0	—	—	V	
		"L"	V _{IN B (L)}		—	—	1.0		
	Input Current	"H"	I _{IN B}		2	V _{IN B} = 1.0 V		200	μA
FG Output	Output Current	"H"	I _{FGH}	3	80	—	—	μA	
	Output Voltage	"L"	V _{FGL}	3	I _{FG} = 0.3 mA		0.4	V	
	Pulse Width		τ _{FG}	3	C = 0.1 μF, R = 10 kΩ		0.9	1.0	1.1

TEST CIRCUIT 1

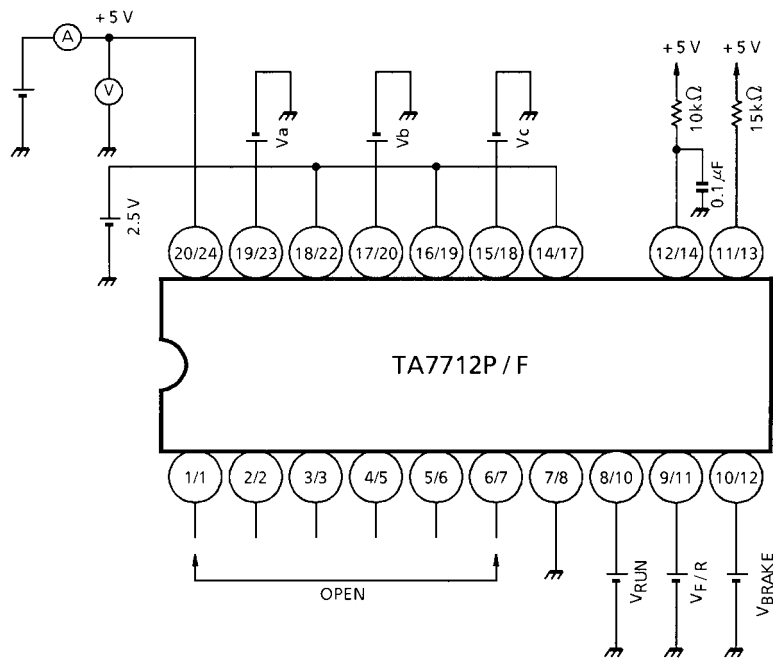

	V _{RUN}	V _{F/R}	V _{BRAKE}	V _a	V _b	V _c	REMARKS
I _{CC1}	1.0 V	1.0 V	1.0 V	2.48 V	2.48 V	2.52 V	Reverse sensing must not be made.
I _{CC2}	4.0 V	4.0 V	4.0 V	2.52 V	2.48 V	2.52 V	

TEST CIRCUIT 2

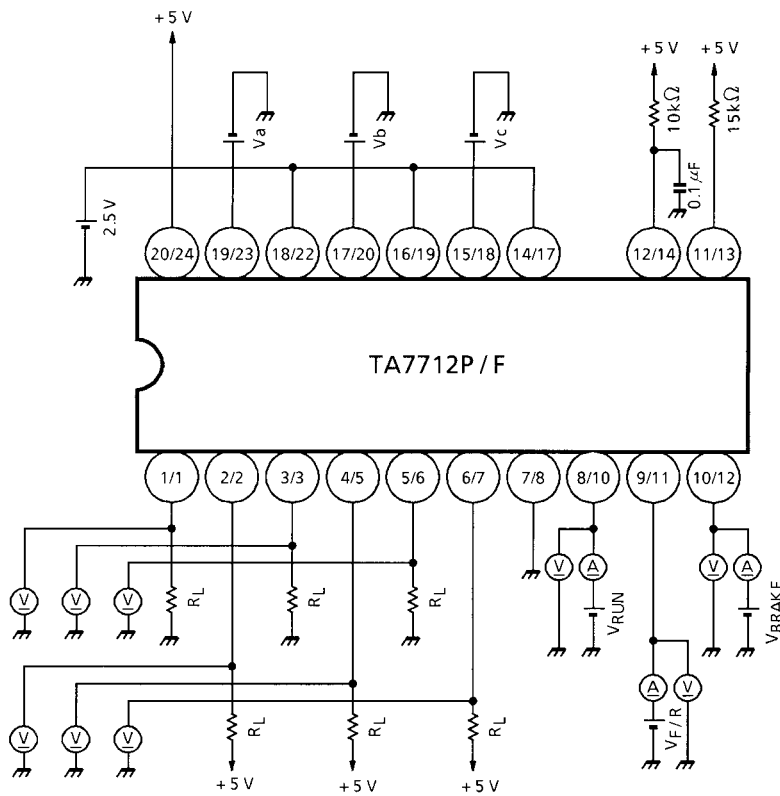

Hall AMP. Input

Check input sensitivity and input hysteresis with ± 20 mV by means of confirming that leak current and saturation voltage described below can be measured.

INPUT CONDITION						MEASUREMENT ITEM					
Va	Vb	Vc	RUN	F / R	BRAKE	La+	La-	Lb+	Lb-	Lc+	Lc-
2.52 V	2.48 V	2.48 V	$V_{IN R (H)}$	$V_{IN C (H)}$	$V_{IN B (H)}$	LEAK	SAT	LEAK	LEAK	SAT	LEAK
2.48 V	2.52 V	2.48 V	—	—	—	SAT	LEAK	—	SAT	LEAK	—
2.48 V	2.48 V	2.52 V	—	—	—	—	—	SAT	—	—	SAT

LEAK: Measurement of leak current

SAT: Measurement of saturation voltage

Confirm "L" of each $V_{IN R}$, $V_{IN C}$ and $V_{IN B}$ through reading the output voltage when each terminal is set at 1.0 (V).

TEST CIRCUIT 3

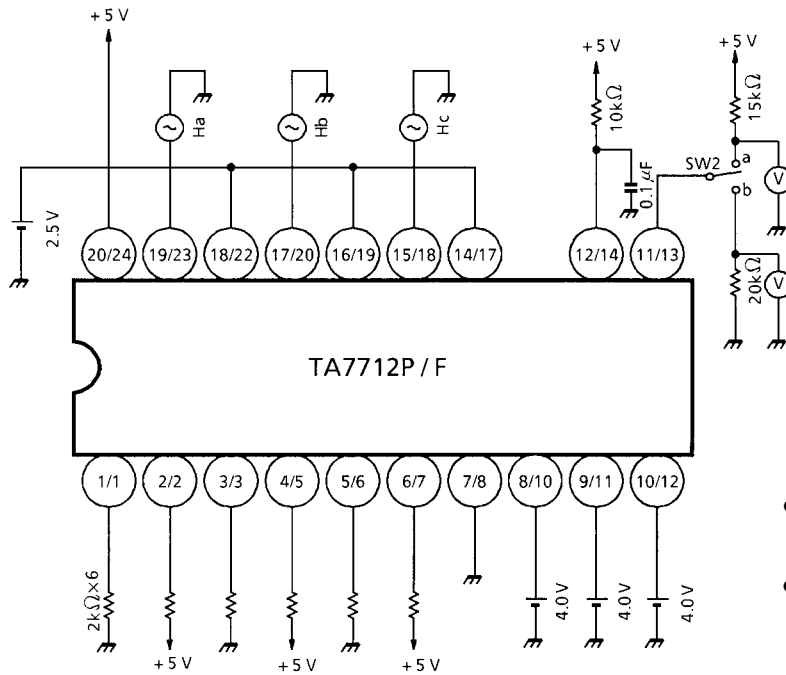

- Measure IFGH with the voltage when SW2 is set at b.
- Measure V_{FG}L and τ_{FG} when SW2 is set at a.

TIME CHART FOR FORWARD ROTATION

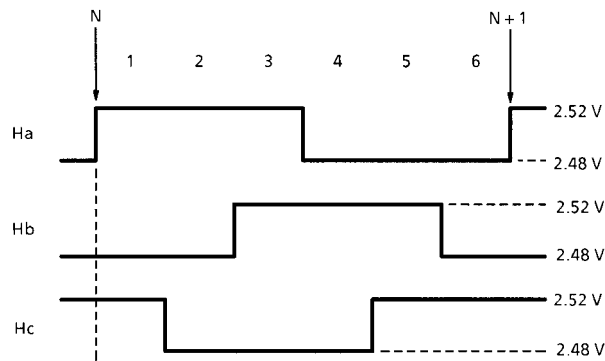

CLOCK 360Hz

BASIC APPLICATION CIRCUIT

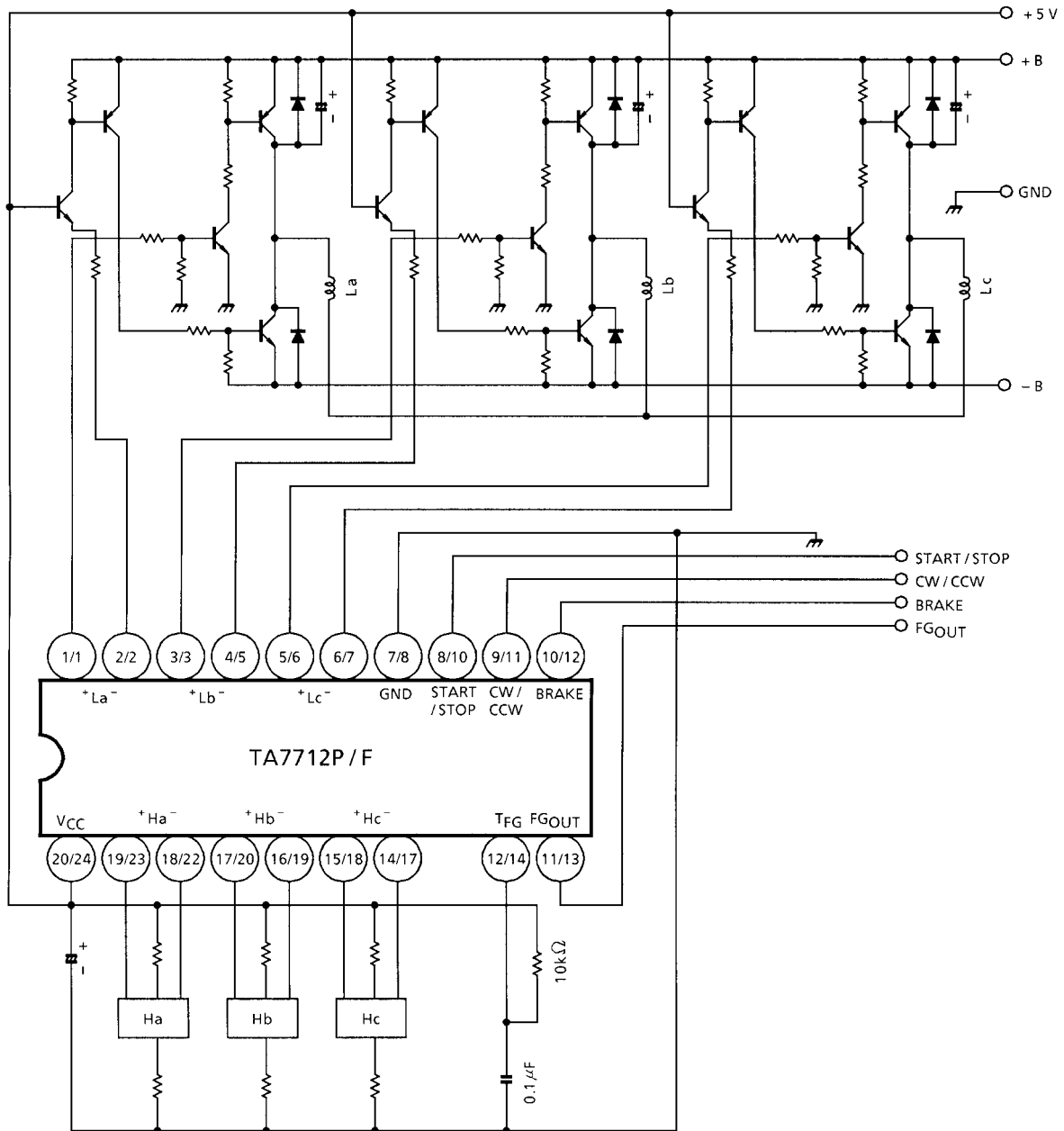

APPLICATION CIRCUIT

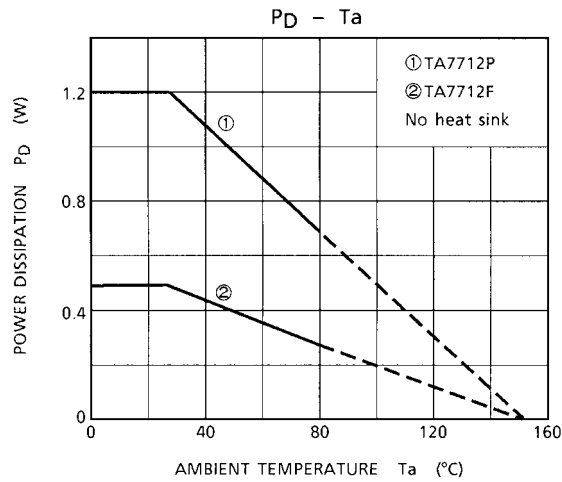
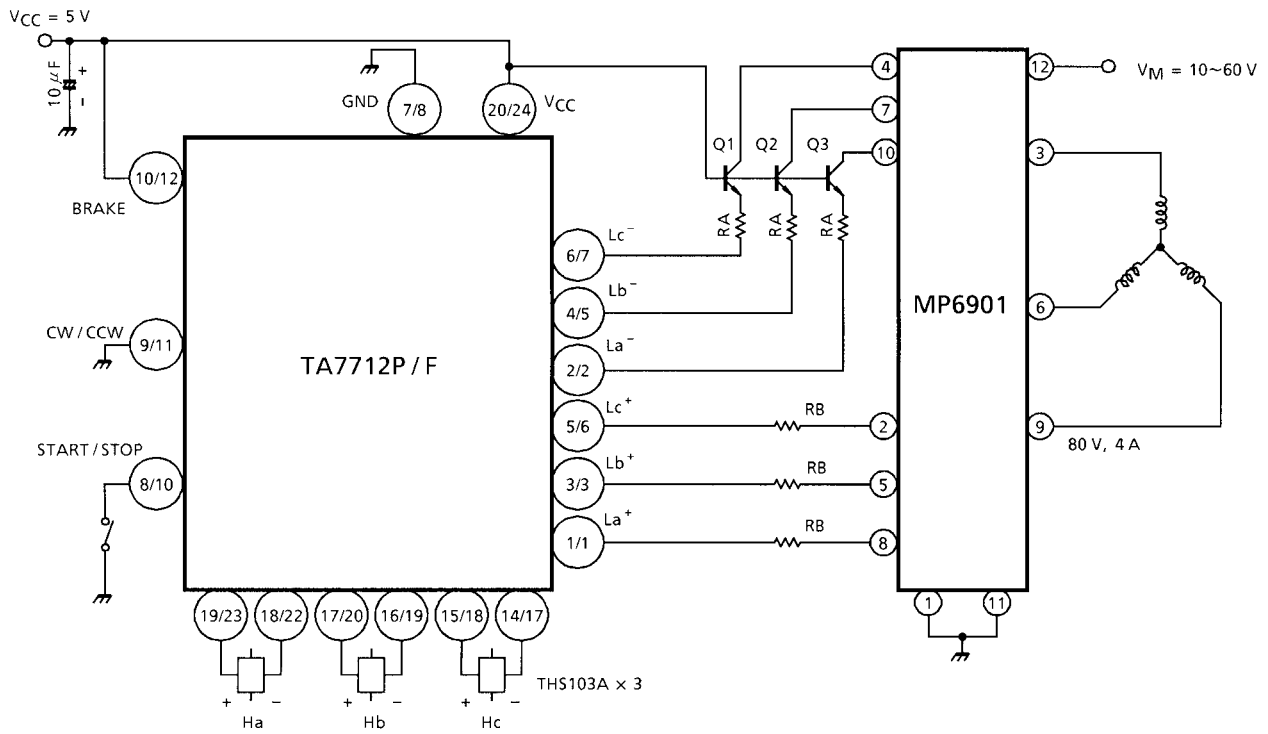

PACKAGE DIMENSIONS

DIP20-P-300-2.54A

Unit: mm

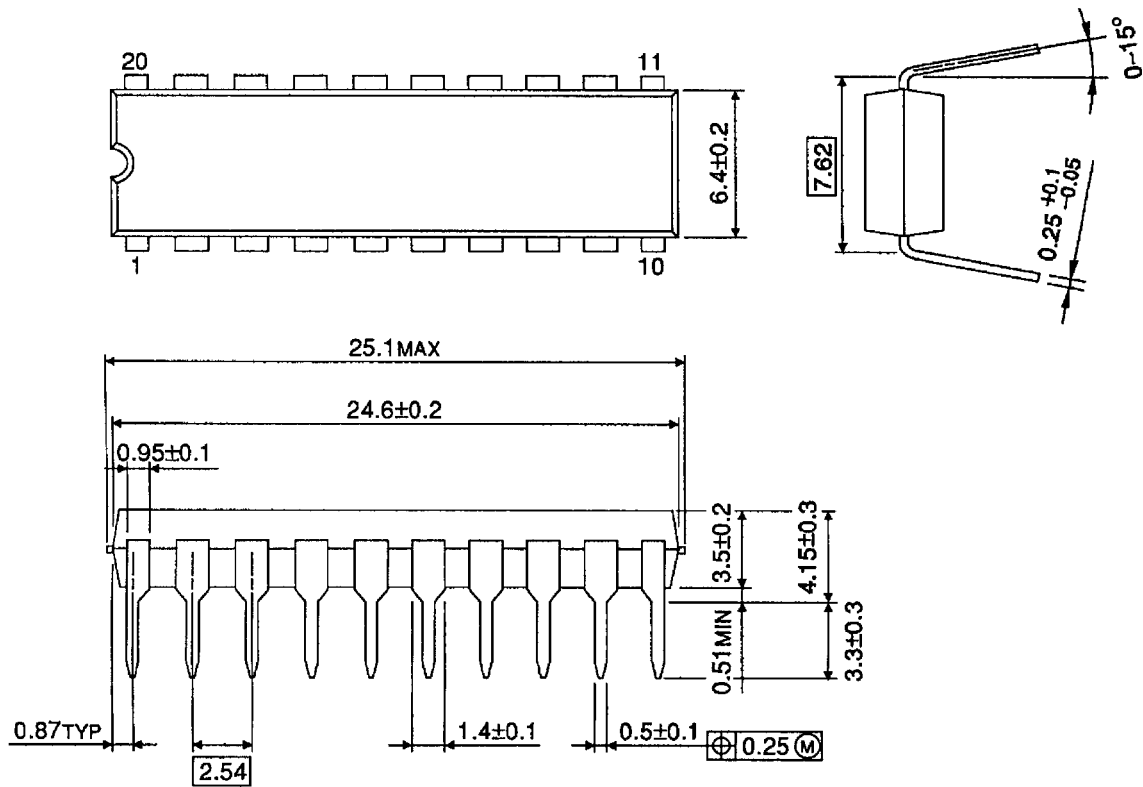

Weight: 2.25 g (Typ.)

PACKAGE DIMENSIONS

SSOP24-P-300-1.00

Unit: mm

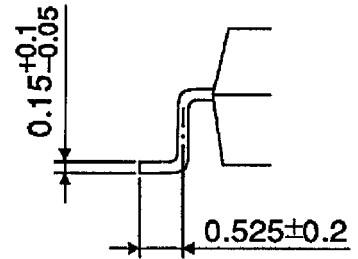
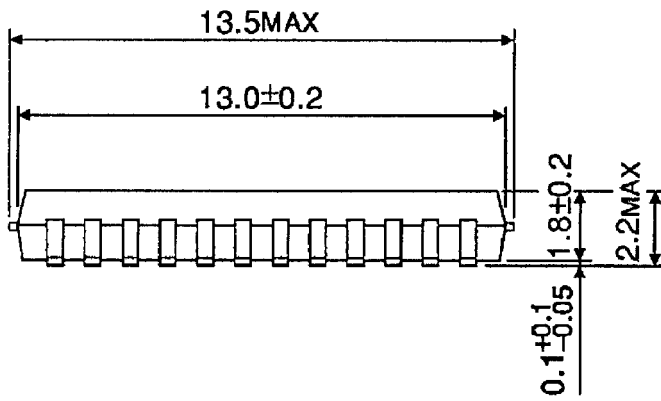
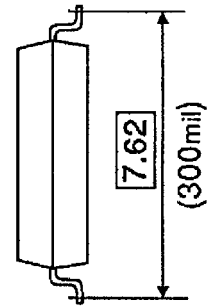
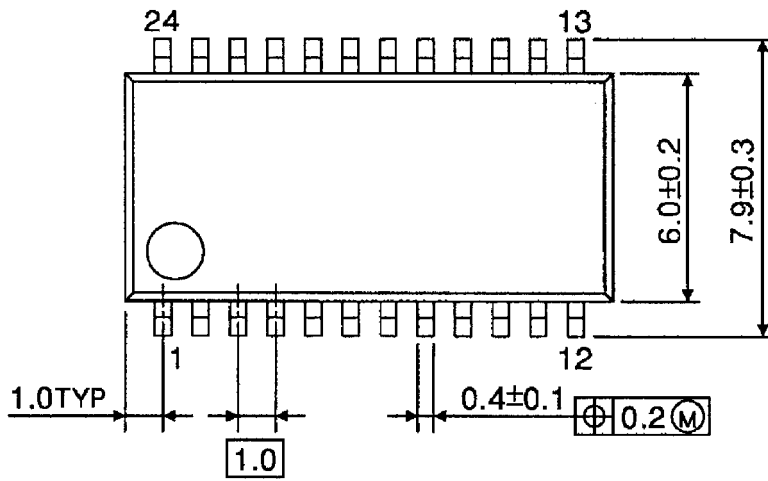

Weight: 0.32 g (Typ.)

RESTRICTIONS ON PRODUCT USE

000707EBA

- TOSHIBA is continually working to improve the quality and reliability of its products. Nevertheless, semiconductor devices in general can malfunction or fail due to their inherent electrical sensitivity and vulnerability to physical stress. It is the responsibility of the buyer, when utilizing TOSHIBA products, to comply with the standards of safety in making a safe design for the entire system, and to avoid situations in which a malfunction or failure of such TOSHIBA products could cause loss of human life, bodily injury or damage to property.
In developing your designs, please ensure that TOSHIBA products are used within specified operating ranges as set forth in the most recent TOSHIBA products specifications. Also, please keep in mind the precautions and conditions set forth in the "Handling Guide for Semiconductor Devices," or "TOSHIBA Semiconductor Reliability Handbook" etc..
- The TOSHIBA products listed in this document are intended for usage in general electronics applications (computer, personal equipment, office equipment, measuring equipment, industrial robotics, domestic appliances, etc.). These TOSHIBA products are neither intended nor warranted for usage in equipment that requires extraordinarily high quality and/or reliability or a malfunction or failure of which may cause loss of human life or bodily injury ("Unintended Usage"). Unintended Usage include atomic energy control instruments, airplane or spaceship instruments, transportation instruments, traffic signal instruments, combustion control instruments, medical instruments, all types of safety devices, etc.. Unintended Usage of TOSHIBA products listed in this document shall be made at the customer's own risk.
- The products described in this document are subject to the foreign exchange and foreign trade laws.
- The information contained herein is presented only as a guide for the applications of our products. No responsibility is assumed by TOSHIBA CORPORATION for any infringements of intellectual property or other rights of the third parties which may result from its use. No license is granted by implication or otherwise under any intellectual property or other rights of TOSHIBA CORPORATION or others.
- The information contained herein is subject to change without notice.

This datasheet has been download from:

www.datasheetcatalog.com

Datasheets for electronics components.